

# 5200 SERIES: Curved Flat Belt End Drive

## Specifications:

- Loads up to 500 lbs. (227 kg)
- Belt speeds up to 280 ft/min (85 m/min)
- Belt widths: 8" (203 mm) –36" (914 mm) in 2" increments
- Conveyor lengths: to 99' (30,175 mm) in 1" increments
- Curves available from 15° - 180° in 15° increments
- UHMW wear strips
- 4.3" diameter drive and idler pulleys
- Two T-slots for mounting accessories
- Rigid 5.8" high anodized aluminum frame



### Optional Interface Tail Section

- Sealed bearing
- 1" (25) diameter rollers provides 2" diameter nose bar
- Widths up to 36"
- Both drive and idler tails available

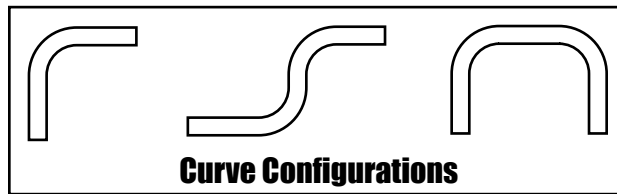

### Curve Configurations

## Features and Benefits:

- Pre-engineered 15° curve segments makes reconfiguration quick and easy
- Quick slots make mounting air and electrical lines simple with no drilling, special tools, fasteners or t-nuts required
- Belt with side tabs for true low side conveying accomodates larger than belt products
- Inside and outside UHMW hold down rails
- Completely contained belt eliminates catenary sag and reduces pinch points
- Designed-in low voltage wire way provides support and protection for low voltage wires running from their electronic device to the main junction or control box
- No holes in side rails makes reconfiguration quick and easy
- Open top frame simplifies belt maintenance and replacement
- Sprocket alignment key provides continuous sprocket alignment for quick belt assembly
- Support stands mounted directly to side rail keep frame open for mounting accessories
- Nose bar tail option



Flush Top,  
Low Side Frame



UHMW Belt  
Tracking Guides



Support Stands Mount  
Directly to Frame

## End Drive Model

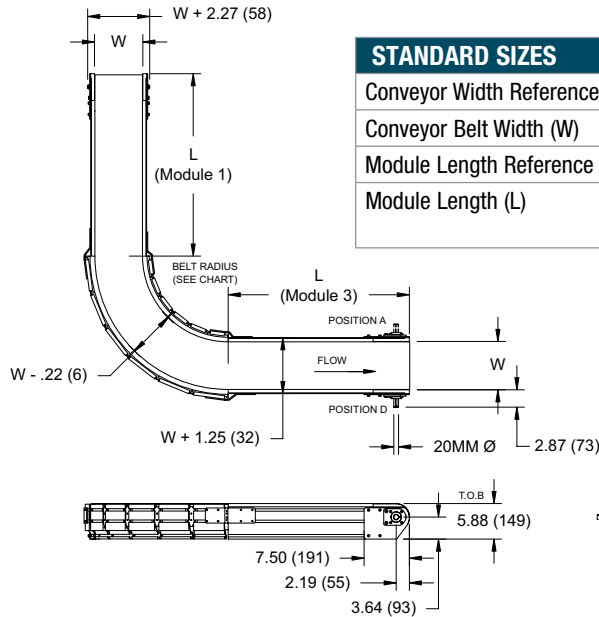

### STANDARD SIZES

Conveyor Width Reference	08	02 increments up to...	36
Conveyor Belt Width (W)	8" (203)	2" (51mm) increments up to...	36" (914mm)
Module Length Reference	020	001 increments up to...	999
Module Length (L)	20" (508)	1" (25mm) increments up to...	999" (25,375mm)

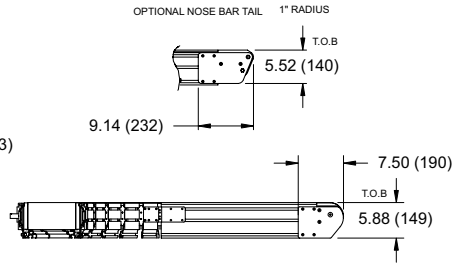

### Belt Width Table

Conveyor Width (inch)	Top of Belt Width	Belt Width Including Tab	Inside Radius of Belt	Frame Width in Straight	Frame Width in Curve
08	7.80	8.55	10.6	9.255	10.905
10	9.81	10.56	14.1	11.230	12.880
12	11.79	12.53	17.5	13.205	14.855
14	13.75	14.50	20.8	15.180	16.830
16	15.72	16.47	24.1	17.155	18.805
18	17.69	18.44	27.4	19.130	20.780
20	19.66	20.41	30.7	21.105	22.755
22	21.63	22.38	33.9	23.080	24.730
24	23.60	24.35	37.2	25.055	26.705
26	25.55	26.29	40.5	27.030	28.680
28	27.51	28.26	43.6	29.005	30.655
30	29.48	30.23	47.0	30.980	32.630
32	31.45	32.20	50.2	32.955	34.605
34	33.42	34.17	53.6	34.930	36.580
36	35.39	36.14	56.8	36.905	38.555

## Nose Bar Drive Model

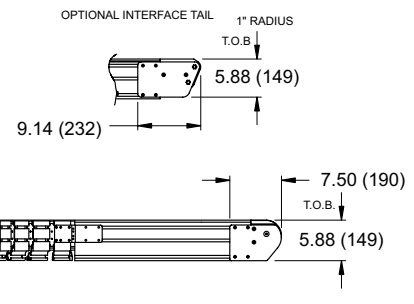
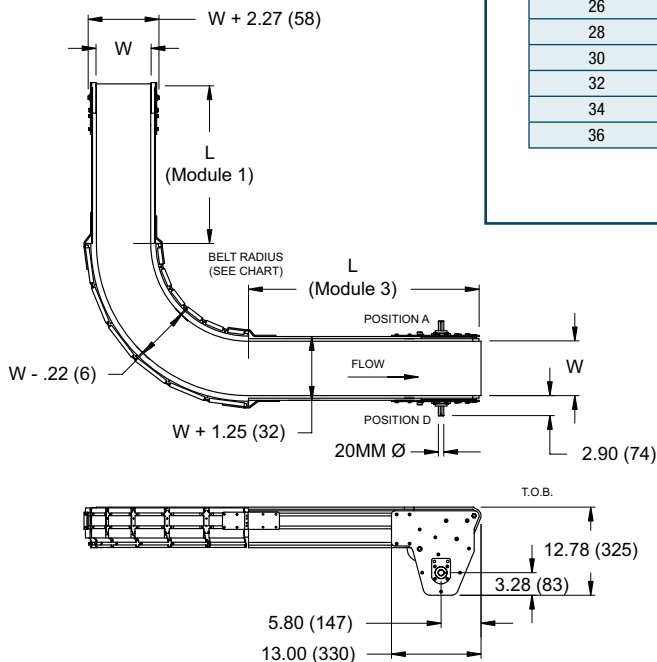

Note: Dimensions are represented in inches, feet, and (millimeters).

Due to the wide variety of drive set-ups and applications, point of installation guarding is the responsibility of the end user.