

GEARMOTOR MOUNTING PACKAGE & GEARMOTOR SELECTION STEPS

- Step 1:** Select a **Gearmotor Mounting Package** (below).
- Step 2:** Locate the appropriate gearmotor chart (pages 205-206) in terms of **Painted** vs. **Stainless Steel** and **Fixed Speed** vs. **Variable Speed**.
- Step 3:** Use the **Belt Speed Column** to locate the **Part Number** for your desired Gearmotor.

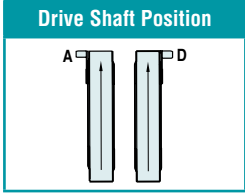

Horizontal Side Drive Mount

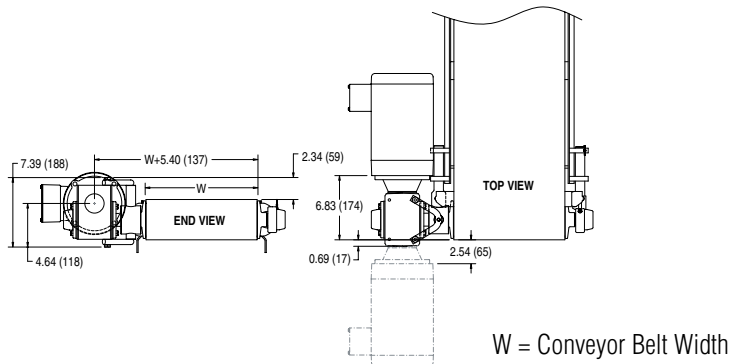

Vertical Side Drive Mount

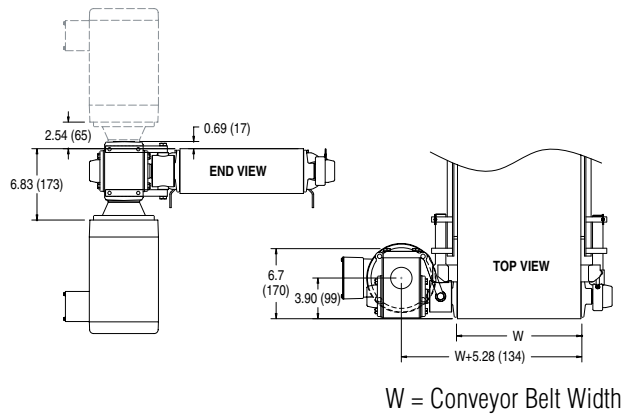

Nose Bar Drive Mount (7400 Ultimate Only)

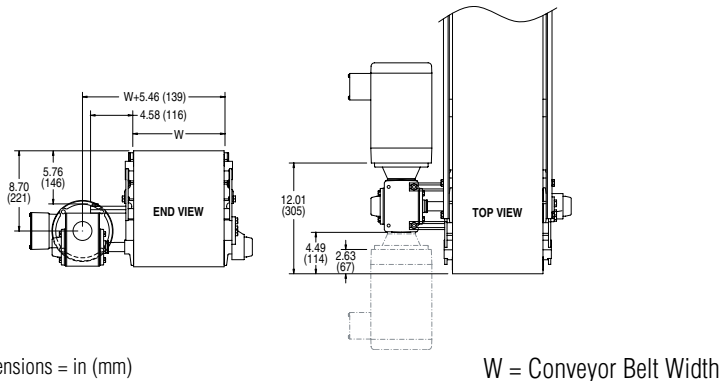

Note: Nose Bar Drive Belt Speed is Limited to 117 ft/min (35.7 m/min) Dimensions = in (mm)