



INTRODUCING THE DORNER iDRIVE

Setting the Standard for Small Parts Handling

iDrive merges advanced drive and control technologies with the compact design of the 2200 Series by integrating the motor, gearbox and motor controller into a single space saving package. Capable of widths as narrow as 3" and lengths as long as 12' with speeds up to 100 ft/min.



Space Saving Design

Sized for Small Part Handling

Reduced Time Required for Conveyor Integration

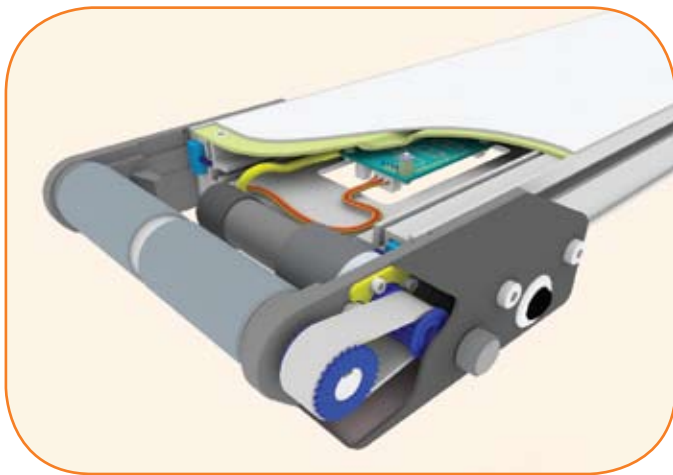

For more information, see the 2200 iDrive section, pages 10-11