

2200 & 2300 SERIES: SUPPORT STANDS

QUANTITY CHARTS

2200 Series Support Stands

Conveyor Length	# of Supports
2' (610) - 4' (1,219)	1*
2' (610) - 6' (1,829)	2
7' (2,134) - 12' (3,658)	3
13' (3,962) - 18' (5,486)	4
19' (5,791) - 24' (7,315)	5

2300 Series Support Stands

Conveyor Length	# of Supports
2' (610) - 8' (2,438)	2
9' (2,743) - 16' (4,877)	3
17' (5,182) - 24' (7,315)	4

Required Return Roller Quantity Chart

Max feet between return rollers												
Conveyor Width	1.75"	2.75"	3.75"	5"	6"	8"	10"	12"	18"	21"	24"	
Flat Belt	8.75	8.5	7.5	7.25	7.0	6.75	6.5	6.0	5.5	5.0	4.5	
Cleated Belt	5.75	5.5	5.25	5.0	4.75	4.5	4.25	4.0	3.5	3.25	3.0	

Quantity of return rollers required = whole number result of: $\frac{\text{conveyor length in feet}}{\text{max distance between return rollers}}$

Example Description: 2200 flat belt 8" wide x 14' long $\frac{14'}{6.75} = 2.07$ **2 return rollers required**

* End Drive Conveyors with Single-Post Support Stands only. Requires the use of diagonal bracing, see page 60. Heavy load gearmotors require a minimum of two stands to support conveyor and gearmotor package.

MOUNTING BRACKETS

Cleated Belt Stand Mounting Bracket

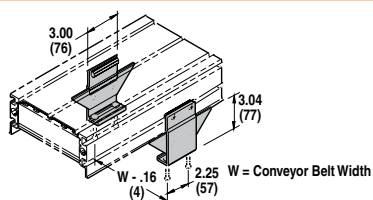

Part Number	Description
240838	Stand Mounting Bracket, 2200 Series Cleated Belt Conveyor
715645	Stand Mounting Bracket, 2300 Series Cleated Belt Conveyor

Flat Belt Stand Mounting Bracket

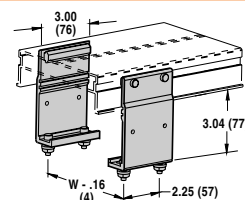

Part Number	Description
240839	Stand Mounting Bracket, 2200 Series Flat Belt Conveyor
715642	Stand Mounting Bracket, 2300 Series Flat Belt Conveyor

Note: Conveyors can be ordered with the required number of mounting brackets. If desired, order additional mounting brackets separately.

RETURN ROLLERS

Cleated Belt Return Roller

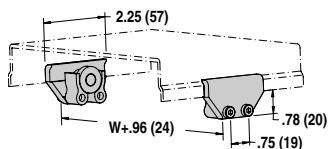

Part Number	Description
240832	Return Roller for 2200 & 2300 Series, Cleated Belt

Flat Belt Return Roller for 2" to 6" Wide Conveyors

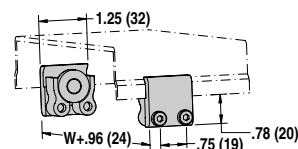

Part Number	Description
240830	Return Roller for 2200 & 2300 Series 2" (44 mm) to 6" (152 mm) wide Flat Belt Conveyor

Flat Belt Return Roller for 8" to 48" Wide Conveyors

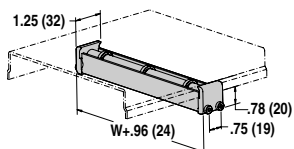

Part Number	Description
3249WW	Return Roller for 2200 & 2300 Series 8" (203 mm) to 48" (1,219 mm) wide Flat Belt Conveyor

WW = Conveyor Width Reference

Note: Conveyors can be ordered with the required number of mounting brackets. If desired, order additional mounting brackets separately.

Note: Dimensions = in (mm)

2200 & 2300 SERIES: SUPPORT STANDS

STAND ACCESSORIES

Adjustable Tie Bracket

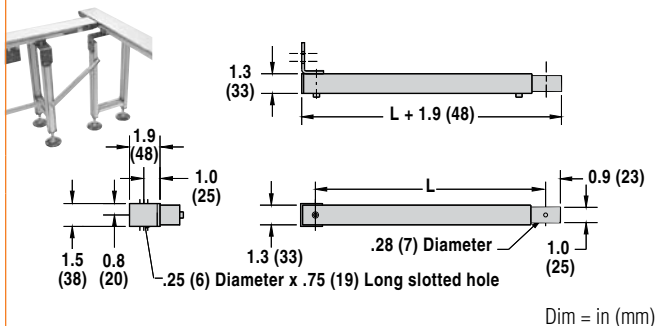

- Compatible with steel and aluminum support stands
- Secure critical stand and conveyor locations
- Length (L) adjusts + 0", - 11.25" (286 mm)
- Includes metric mounting hardware

Part Number	Description
27M400-02	Adjustable Tie Bracket, 2' (610 mm)
27M400-03	Adjustable Tie Bracket, 3' (914 mm)
27M400-04	Adjustable Tie Bracket, 4' (1,219 mm)
27M400-05	Adjustable Tie Bracket, 5' (1,524 mm)
27M400-06	Adjustable Tie Bracket, 6' (1,829 mm)

Bottom Mount Stand Bracket

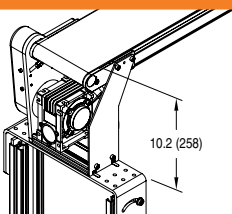

*Not compatible with MPB option.

- Bolts to 90° standard load gearmotor
- Includes metric mounting hardware
- Provides a 10.2" (258) T.O.B. Height

Part Number	Description
202306-02	"L" Bracket only for 2" to 5" wide conveyors
202306-WW	Bracket Assembly, 06 and wider 2200 & 2300 conveyors

Diagonal Bracing



*Not compatible with MPB option.

- For use on steel, aluminum and single post support stands with casters
- Metric fastener mounting hardware included
- For use on all stands with casters and any stands over 72" (1829 mm) tall
- One brace per stand for conveyors up to 24" wide (610 mm)
- Two braces per stand for conveyors over 24" wide (610 mm)

2200 Part Number	2300 Part Number	Description
39MB-TS	39MB-FS	for two-legged H style & A-Frame stands up to 30" tall (762 mm)
39MB-TT	39MB-FT	for two-legged H style & A-Frame stands over 30" tall (762 mm)
39MB-PT	39MB-PT	for Single Post and Pillar stands over 30" tall (762 mm)

Common Mount Kit

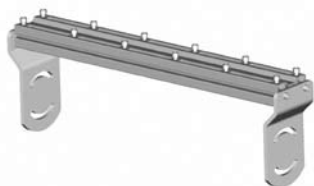

- Stand accessory for mounting multiple conveyors in parallel to one stand
- Adds 2" (51 mm) to stand height
- Adds 2.79" (71 mm) to overall stand width

For ordering information, see page 74

Tall Support Stands



Outriggers

Tall Stands are the Fixed Height and Adjustable Height Stands as shown with additional outrigger support for added stability. These outriggers are required when the height of the stand exceeds 3.5x its width, and they add 16" to stand width. Tall stands over 6' tall include diagonal bracing.

Fine Adjustment Kit

- Provides fine height adjustment via a threaded bolt
- For use with Fixed Height Stands

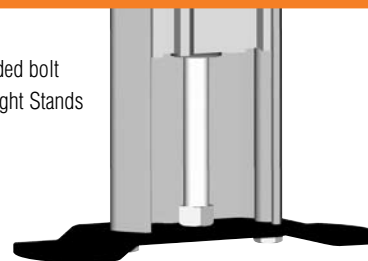

Part # 710028

2200 & 2300 SERIES: SUPPORT STANDS

FIXED HEIGHT SUPPORT STANDS

Fixed Foot Model

Stand Width (WW)	12" (305mm)	2" (51mm) increments up to...	48" (1,219mm)
Part # Reference	12	in 02 increments up to...	48
Stand Height (HH)*	15" - 19" (381 - 483mm)	in 1" (25mm) increments up to...	95" - 99" (2,413 - 2,515mm)
Part # Reference	1519	in 0101 increments up to...	9599

Swivel Locking Caster Model

Stand Width (WW)	12" (305mm)	2" (51mm) increments up to...	48" (1,219mm)
Part # Reference	12	in 02 increments up to...	48
Stand Height (HH)*	20" - 24" (508 - 610mm)	in 1" (25mm) increments up to...	68" - 72" (1,727 - 1,829mm)
Part # Reference	2024	in 0101 increments up to...	6872

- Metric fasteners
- 4" (102 mm) Height Adjustment

* Dependent on stand width, stands over 42" (1,067 mm) may include outriggers (see page 60)

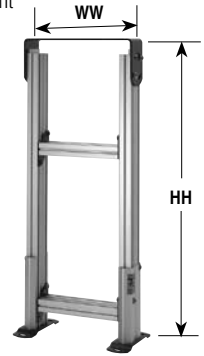

Full width is top plate on 12" wide stands only

ADJUSTABLE HEIGHT SUPPORT STANDS

Fixed Foot Model

Stand Width (WW)	12" (305mm)		2" (51mm) increments up to...				48" (1,219mm)				
Part # Reference	12		in 02 increments up to...				48				
Stand Height (HH)	12-13" (305-330)	13-15" (330-381)	14-17" (356-432)	16-21" (406-660)	19-26" (483-686)	24-36" (610-914)	30-48" (762-1,219)	42-60** (1,067-1,524)	54-72** (1,372-1,829)	66-84** (1,676-2,134)	78-96** (1,981-2,438)
Part # Reference	1213	1315	1417	1621	1926	2436	3048	4260	5472	6684	7896

Swivel Locking Caster Model

Stand Width (WW)	12" (305mm)		2" (51mm) increments up to...				48" (1,219mm)				
Part # Reference	12		in 02 increments up to...				48				
Stand Height (HH)	17-18" (432-457)	18-20" (457-508)	19-22" (483-559)	21-26" (533-660)	24-31" (610-787)	29-41" (737-1,041)	35-53" (762-1,346)	47-65** (1,194-1,651)	59-77** (1,499-1,956)		
Part # Reference	1718	1820	1922	2126	2431	2941	3553	4765	5977		

- Metric fasteners

* Dependent on stand width, stands over 42" (1,067 mm) may include outriggers (see page 60)

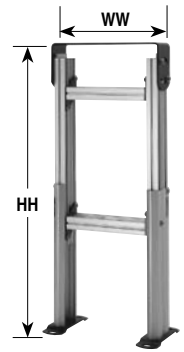

Full width is top plate on 12" wide stands only

SINGLE POST & PILLAR SUPPORT STANDS

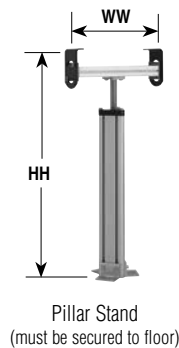
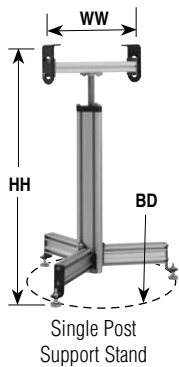

Standard Sizes

Stand Width (WW)	1.75" (44)	2.75" (70)	3.75" (95)	5" (44)	6" (152)	8" (203)	10" (254)	12" (305)	14" (356)	16" (406)	18" (457)
Part # Reference	02	03	04	05	06	08	10	12	14	16	18
Stand Height (HH)*	16-26" (406-660)		24-34" (610-864)		32-42" (813-1,067)		40-50" (1,016-1,270)		48-58" (1,219-1,473)		
Part # Reference	16		24		32		40		48		
Base Diameter (BD)	24" (610)		27" (686)		30" (762)		33" (838)		36" (915)		

- Casters do not change overall height
- Metric fasteners

Note: Due to the wide variety of conveyor and stand options along with possible configurations, stability of the final setup is the responsibility of the end user.

For ordering information, see page 75

2200 & 2300 SERIES: SUPPORT STANDS

SHORT SUPPORT STANDS

Fixed Foot Model

Stand Width (WW)	12" (305mm)	2" (51mm) increments up to...	48" (1,219mm)
Part # Reference	12	in 02 increments up to...	48
Stand Height (HH)*	06" - 08" (152 - 203mm)	in 1" (25mm) increments up to...	12" - 14" (305 - 356mm)
Part # Reference	0608	in 0101 increments up to...	1214

Swivel Locking Caster Model

Stand Width (WW)	12" (305mm)	2" (51mm) increments up to...	48" (1,219mm)
Part # Reference	12	in 02 increments up to...	48
Stand Height (HH)*	11" - 13" (279 - 330mm)	in 1" (25mm) increments up to...	17" - 19" (305 - 483mm)
Part # Reference	1113	in 0101 increments up to...	1719

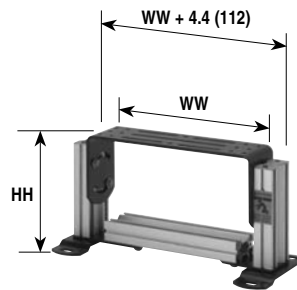

Full width is top plate on 12" wide stands only

FULLY ADJUSTABLE SUPPORT STANDS

Fixed Foot Model

Stand Width (WW)	1.75" (44)	2.75" (70)	3.75" (95)	5" (44)	6" (152)	2" (51mm) increments up to...	48" (1,219)
Part # Reference	02	03	04	05	06	in 02 increments up to...	48
Top of Belt Range	7-19" (179-483)	12-31" (305-787)	12-43" (305-1,097)	12-55" (305-1,397)	12-67" (305-1,702)		
Stand Height Reference	0719	1231	1243	1255	1267		

Swivel Locking Caster Model

Stand Width (WW)	1.75" (44)	2.75" (70)	3.75" (95)	5" (44)	6" (152)	2" (51mm) increments up to...	48" (1,219)
Part # Reference	02	03	04	05	06	in 02 increments up to...	48
Top of Belt Range	12-19" (305-483)	17-31" (432-787)	17-43" (432-1,097)	17-55" (432-1,397)	17-67" (432-1,702)		
Stand Height Reference	1219	1731	1743	1755	1767		

- Metric fasteners

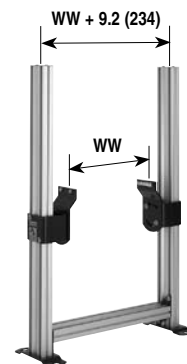

MULTI TIER STANDS

Minimum Tier Height Per Conveyor

Flat Belt	12" (305mm)
Cleated Belt	15" (381mm)

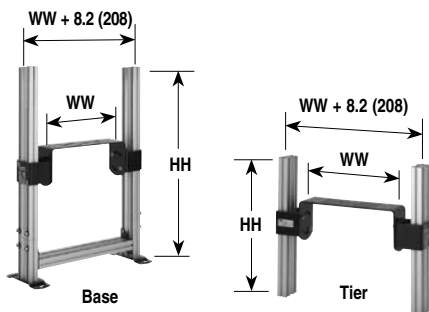

Full width is top plate on 12" wide stands only

Base

Stand Width (WW)	12" (305mm)	2" (51mm) increments up to...	48" (1,219mm)
Part # Reference	12	in 02 increments up to...	48
Stand Height (HH)*	12" (305mm)	2" (51mm) increments up to...	60" (1,524mm)
Part # Reference	1212	in 0002 increments up to...	1260

Tier

Stand Width (WW)	12" (305mm)	2" (51mm) increments up to...	48" (1,219mm)
Part # Reference	12	in 02 increments up to...	48
Stand Height (HH)*	12" (305mm)	1" (25mm) increments up to...	36" (914mm)
Part # Reference	0712	in 0002 increments up to...	0736

Note: Do not use with support stands equipped with casters. Support Stands must be anchored to the floor. Do not use if conveyed product overhangs the edge of the conveyor belt due to pinch point created.

2200 & 2300 SERIES: SUPPORT STANDS

QUICK ADJUST STANDS

Fixed Foot Model

Stand Width (WW)*	12" (305mm)	2" (51mm) increments up to...	36" (914mm)
Part # Reference	12	in 02 increments up to...	36
Stand Height (HH)*	24" - 30" (610 - 762mm)	in 1" (25mm) increments up to...	66" - 72" (1,676 - 1,829mm)
Part # Reference	2430	in 0101 increments up to...	6672

Swivel Locking Caster Model

Stand Width (WW)*	12" (305mm)	2" (51mm) increments up to...	36" (914mm)
Part # Reference	12	in 02 increments up to...	36
Stand Height (HH)*	27" - 33" (686 - 838mm)	in 1" (25mm) increments up to...	60" - 66" (1,524 - 1,676mm)
Part # Reference	2733	in 0101 increments up to...	6066

* Under 12" wide use full top plate option

- Metric fasteners
- +/- 3" (76 mm) Height Adjustment
- Allows for Quick Height Adjustment
- Tool-less lock and adjustment handles



Fixed Foot Model

Swivel Locking Caster Model

A-FRAME STANDS

Fixed Foot Model

Stand Width (WW)	1.75" (44mm)	2" (51mm) increments up to...	24" (610mm)
Part # Reference	02	in 02 increments up to...	24
Stand Height (HH)*	10" - 14" (254 - 356mm)	in 1" (25mm) increments up to...	56" - 60" (1,422 - 1,524mm)
Part # Reference	1014	in 0101 increments up to...	5660

Swivel Locking Caster Model

Stand Width (WW)	1.75" (44mm)	2" (51mm) increments up to...	24" (610mm)
Part # Reference	02	in 02 increments up to...	24
Stand Height (HH)*	13" - 15" (330 - 381mm)	in 1" (25mm) increments up to...	58" - 60" (1,473 - 1,524mm)
Part # Reference	2733	in 0101 increments up to...	5860

* From floor to top of belt

- Metric fasteners
- +/- 2" (51 mm) Height Adjustment for Fixed Foot Model
- +/- 1" (25 mm) Height Adjustment for Fixed Foot Model
- One (1) SmartSlot per side



Fixed Foot Model

Swivel Locking Caster Model

Note: Dimensions = in (mm)

Due to the wide variety of drive set ups and applications, point of installation guarding is the responsibility of the end user.

Note: Due to the wide variety of conveyor and stand options along with possible configurations, stability of the final setup is the responsibility of the end user.

For ordering information, see page 75