

QUANTITY CHARTS

| 3200 Series | |
|-----------------------------|--------------------|
| Conveyor Length | Number of Supports |
| 3' (914) - 13' (3,962) | 2 |
| 14' (4,267) - 25' (7,620) | 3 |
| 26' (7,925) - 37' (11,278) | 4 |
| 38' (11,592) - 49' (14,932) | 5 |
| 50' (15,240) - 61' (18,593) | 6 |
| 62' (18,898) - 73' (22,250) | 7 |
| 74' (22,555) - 85' (25,908) | 8 |
| 86' (26,213) - 97' (29,506) | 9 |
| 98' (29,870) - 99' (30,175) | 10 |

| Z-frame Flat Belt Conveyors | | |
|-----------------------------------|--------------------------------|------------------|
| Nose-over and Walk-Thru Conveyors | | |
| Section Length | Number of Supports per Section | |
| | Section L2 | Sections L1 & L3 |
| 2' to 13' | 2 | 1 |
| 14' to 25' | 3 | 2 |
| 26' to 37' | 4 | 3 |
| 38' to 49' | 5 | 4 |
| 50' to 61' | 6 | 5 |
| 62' to 73' | 7 | 6 |
| 74' to 85' | 8 | 7 |
| 86' to 97' | 9 | 8 |

| Z-frame Cleated Belt Conveyors | |
|-------------------------------------|--------------------|
| Horizontal to Incline and Nose-over | |
| Total Conveyor Length | Number of Supports |
| 4' and 5' | 2 |
| 5' to 25' | 3 |

| Z-frame Cleated Belt Conveyors | |
|--------------------------------|--------------------|
| Z-Frame | |
| Total Conveyor Length | Number of Supports |
| 6' to 9' | 3 |
| 10' to 25' | 4 |

3200 & Z-frame (per section) Required Return Roller

| Conveyor Width | max feet between return rollers | | | | |
|----------------|---------------------------------|-----------|-----------|-----------|-----------|
| | 3.75" - 10" | 12" - 20" | 22" - 30" | 32" - 40" | 40" - 48" |
| Flat Belt | 8 | 7 | 6 | 5 | 4 |
| Cleated Belt | 6 | 5 | 4 | n/a | n/a |

Quantity of return rollers required = whole number result of: $\frac{\text{conveyor length in feet}}{\text{max distance between return rollers}}$

Example Description: 3200 cleated belt 18" wide x 21' long $\frac{21'}{5} = 4.2$ **4 return rollers required**

MOUNTING BRACKETS

Cleated Stand Mounting Bracket

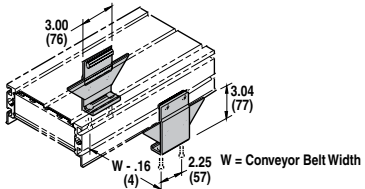

| Part Number | Description |
|-------------|---|
| 240838 | Stand Mounting Bracket, Cleated Belt Conveyor |

Flat Belt Stand Mounting Bracket

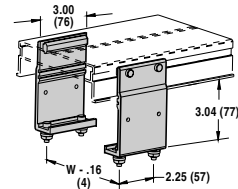

| Part Number | Description |
|-------------|--|
| 240839 | Stand Mounting Bracket, Flat Belt Conveyor |

Note: Conveyors can be ordered with the required number of mounting brackets. If desired, order additional mounting brackets separately.

RETURN ROLLERS

Cleated Belt Return Roller

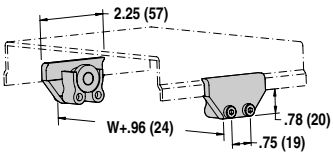

| Part Number | Description |
|-------------|--|
| 240832 | Return Roller for Cleated Belt conveyors |

Flat Belt Return Roller for 2" to 6" Wide Conveyors

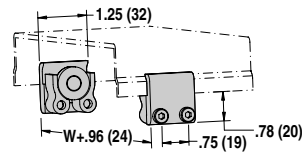

| Part Number | Description |
|-------------|---|
| 240830 | Return Roller for 2" - 6" (44 mm - 152 mm) wide Flat Belt conveyors |

Flat Belt Return Roller for 8" to 48" Wide Conveyors

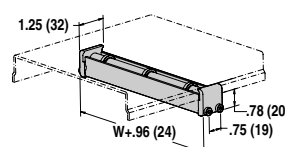

| Part Number | Description |
|-------------|---|
| 3249WW | Return Roller for 3200 Series 8" (203 mm) to 48" (1,219 mm) wide Flat Belt Conveyor |

Note: Dimensions = in (mm)

Note: Due to the wide variety of conveyor and stand options along with possible configurations, stability of the final setup is the responsibility of the end user.

3200 SERIES: SUPPORT STANDS

FIXED HEIGHT SUPPORT STANDS

Fixed Foot Model

| | | | |
|--------------------|----------------------------|----------------------------------|--------------------------------|
| Stand Width (WW) | 12" (305mm) | 2" (51mm) increments up to... | 48" (1,219mm) |
| Part # Reference | 12 | in 02 increments up to... | 48 |
| Stand Height (HH)* | 15" - 19" (381 - 483mm) | in 1" (25mm) increments up to... | 95" - 99" (2,413 - 2,515mm) |
| Part # Reference | 1519 | in 0101 increments up to... | 9599 |

Swivel Locking Caster Model

| | | | |
|--------------------|----------------------------|----------------------------------|--------------------------------|
| Stand Width (WW) | 12" (305mm) | 2" (51mm) increments up to... | 48" (1,219mm) |
| Part # Reference | 12 | in 02 increments up to... | 48 |
| Stand Height (HH)* | 20" - 24" (508 - 610mm) | in 1" (25mm) increments up to... | 68" - 72" (1,727 - 1,829mm) |
| Part # Reference | 2024 | in 0101 increments up to... | 6872 |

- Metric fasteners
- 4" (102mm) Height Adjustment

* Dependent on stand width, stands over 42" (1,067 mm) may include outriggers (see page 116)

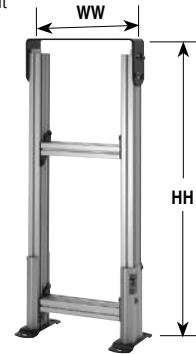

Full width is top plate on 12" wide stands only

ADJUSTABLE HEIGHT SUPPORT STANDS

Fixed Foot Model

| | | | | | | | | | | | |
|-------------------|---------------------|-------------------------------|---------------------|---------------------|---------------------|---------------------|-----------------------|--------------------------|--------------------------|--------------------------|--------------------------|
| Stand Width (WW) | 12" (305mm) | 2" (51mm) increments up to... | | | | | | 48" (1,219mm) | | | |
| Part # Reference | 12 | in 02 increments up to... | | | | | | 48 | | | |
| Stand Height (HH) | 12-13" (305-330) | 13-15" (330-381) | 14-17" (356-432) | 16-21" (406-660) | 19-26" (483-686) | 24-36" (610-914) | 30-48" (762-1,219) | 42-60"* (1,067-1,524) | 54-72"* (1,372-1,829) | 66-84"* (1,676-2,134) | 78-96"* (1,981-2,438) |
| Part # Reference | 1213 | 1315 | 1417 | 1621 | 1926 | 2436 | 3048 | 4260 | 5472 | 6684 | 7896 |

Swivel Locking Caster Model

| | | | | | | | | | | | |
|-------------------|---------------------|-------------------------------|---------------------|---------------------|---------------------|-----------------------|-----------------------|--------------------------|--------------------------|--|--|
| Stand Width (WW) | 12" (305mm) | 2" (51mm) increments up to... | | | | | | 48" (1,219mm) | | | |
| Part # Reference | 12 | in 02 increments up to... | | | | | | 48 | | | |
| Stand Height (HH) | 17-18" (432-457) | 18-20" (457-508) | 19-22" (483-559) | 21-26" (533-660) | 24-31" (610-787) | 29-41" (737-1,041) | 35-53" (762-1,346) | 47-65"* (1,194-1,651) | 59-77"* (1,499-1,956) | | |
| Part # Reference | 1718 | 1820 | 1922 | 2126 | 2431 | 2941 | 3553 | 4765 | 5977 | | |

- Metric fasteners

* Dependent on stand width, stands over 42" (1,067 mm) may include outriggers (see page 116)

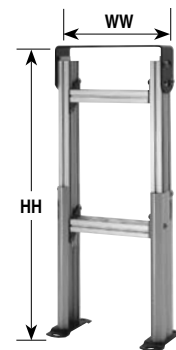

Full width is top plate on 12" wide stands only

SINGLE POST & PILLAR SUPPORT STANDS

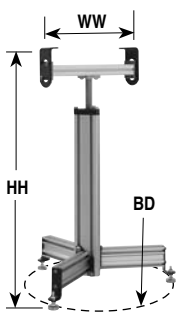

Single Post Support Stand

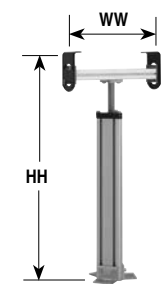

Pillar Stand (must be secured to floor)

Standard Sizes

| | | | | | | | | | | | |
|--------------------|---------------------|---------------|---------------------|------------|-----------------------|-------------|-------------------------|--------------|-------------------------|--------------|--------------|
| Stand Width (WW) | 1.75" (44) | 2.75" (70) | 3.75" (95) | 5" (44) | 6" (152) | 8" (203) | 10" (254) | 12" (305) | 14" (356) | 16" (406) | 18" (457) |
| Part # Reference | 02 | 03 | 04 | 05 | 06 | 08 | 10 | 12 | 14 | 16 | 18 |
| Stand Height (HH)* | 16-26" (406-660) | | 24-34" (610-864) | | 32-42" (813-1,067) | | 40-50" (1,016-1,270) | | 48-58" (1,219-1,473) | | |
| Part # Reference | 16 | | 24 | | 32 | | 40 | | 48 | | |
| Base Diameter (BD) | 24" (610) | | 27" (686) | | 30" (762) | | 33" (838) | | 36" (915) | | |

- Casters do not change overall height
- Metric fasteners

Note: Due to the wide variety of conveyor and stand options along with possible configurations, stability of the final setup is the responsibility of the end user.

For ordering information, see page 126

SHORT SUPPORT STANDS

Fixed Foot Model

| | | | |
|--------------------|----------------------------|----------------------------------|----------------------------|
| Stand Width (WW) | 12" (305mm) | 2" (51mm) increments up to... | 48" (1,219mm) |
| Part # Reference | 12 | in 02 increments up to... | 48 |
| Stand Height (HH)* | 06" - 08" (152 - 203mm) | in 1" (25mm) increments up to... | 12" - 14" (305 - 356mm) |
| Part # Reference | 0608 | in 0101 increments up to... | 1214 |

Swivel Locking Caster Model

| | | | |
|--------------------|----------------------------|----------------------------------|----------------------------|
| Stand Width (WW) | 12" (305mm) | 2" (51mm) increments up to... | 48" (1,219mm) |
| Part # Reference | 12 | in 02 increments up to... | 48 |
| Stand Height (HH)* | 11" - 13" (279 - 330mm) | in 1" (25mm) increments up to... | 17" - 19" (305 - 483mm) |
| Part # Reference | 1113 | in 0101 increments up to... | 1719 |

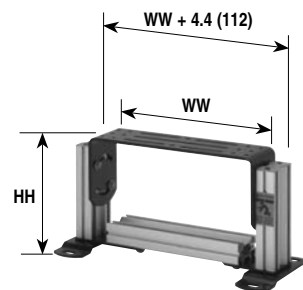

Full width is top plate on 12" wide stands only

FULLY ADJUSTABLE SUPPORT STANDS

Fixed Foot Model

| | | | | | | | |
|------------------------|--------------------|---------------|---------------------|------------|-----------------------|-------------------------------|-----------------------|
| Stand Width (WW) | 1.75" (44) | 2.75" (70) | 3.75" (95) | 5" (44) | 6" (152) | 2" (51mm) increments up to... | 48" (1,219) |
| Part # Reference | 02 | 03 | 04 | 05 | 06 | in 02 increments up to... | 48 |
| Top of Belt Range | 7-19" (179-483) | | 12-31" (305-787) | | 12-43" (305-1,097) | 12-55" (305-1,397) | 12-67" (305-1,702) |
| Stand Height Reference | 0719 | | 1231 | | 1243 | 1255 | 1267 |

Swivel Locking Caster Model

| | | | | | | | |
|------------------------|---------------------|---------------|---------------------|------------|-----------------------|-------------------------------|-----------------------|
| Stand Width (WW) | 1.75" (44) | 2.75" (70) | 3.75" (95) | 5" (44) | 6" (152) | 2" (51mm) increments up to... | 48" (1,219) |
| Part # Reference | 02 | 03 | 04 | 05 | 06 | in 02 increments up to... | 48 |
| Top of Belt Range | 12-19" (305-483) | | 17-31" (432-787) | | 17-43" (432-1,097) | 17-55" (432-1,397) | 17-67" (432-1,702) |
| Stand Height Reference | 1219 | | 1731 | | 1743 | 1755 | 1767 |

- Metric fasteners

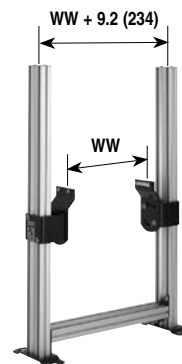

MULTI TIER STANDS

Minimum Tier Height Per Conveyor

| | |
|--------------|-------------|
| Flat Belt | 12" (305mm) |
| Cleated Belt | 15" (381mm) |

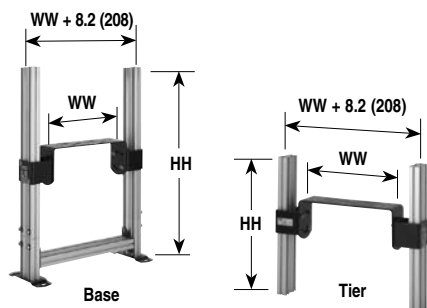

Full width is top plate on 12" wide stands only

Base

| | | | |
|--------------------|-------------|-------------------------------|---------------|
| Stand Width (WW) | 12" (305mm) | 2" (51mm) increments up to... | 48" (1,219mm) |
| Part # Reference | 12 | in 02 increments up to... | 48 |
| Stand Height (HH)* | 12" (305mm) | 2" (51mm) increments up to... | 60" (1,524mm) |
| Part # Reference | 1212 | in 0002 increments up to... | 1260 |

Tier

| | | | |
|--------------------|-------------|-------------------------------|---------------|
| Stand Width (WW) | 12" (305mm) | 2" (51mm) increments up to... | 48" (1,219mm) |
| Part # Reference | 12 | in 02 increments up to... | 48 |
| Stand Height (HH)* | 12" (305mm) | 1" (25mm) increments up to... | 36" (914mm) |
| Part # Reference | 0712 | in 0002 increments up to... | 0736 |

Note: Do not use with support stands equipped with casters. Support Stands must be anchored to the floor. Do not use if conveyed product overhangs the edge of the conveyor belt due to pinch point created.

Note: Due to the wide variety of conveyor and stand options along with possible configurations, stability of the final setup is the responsibility of the end user.

For ordering information, see page 126

3200 SERIES: SUPPORT STANDS

STAND ACCESSORIES

Adjustable Tie Bracket

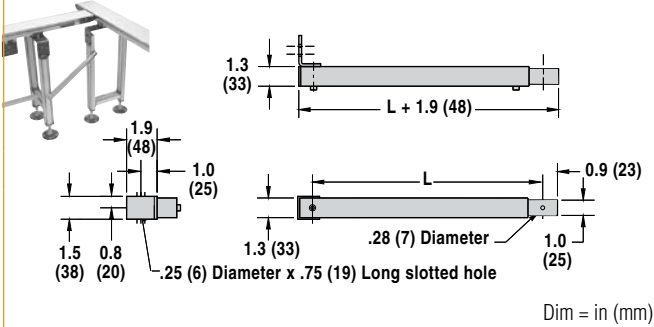

- Compatible with steel and aluminum support stands
- Secure critical stand and conveyor locations
- Length (L) adjusts + 0", - 11.25" (286mm)
- Includes metric mounting hardware

| Part Number | Description |
|-------------|---------------------------------------|
| 27M400-02 | Adjustable Tie Bracket, 2' (610 mm) |
| 27M400-03 | Adjustable Tie Bracket, 3' (914 mm) |
| 27M400-04 | Adjustable Tie Bracket, 4' (1,219 mm) |
| 27M400-05 | Adjustable Tie Bracket, 5' (1,524 mm) |
| 27M400-06 | Adjustable Tie Bracket, 6' (1,829 mm) |

Diagonal Bracing



- For use on steel, aluminum and single post support stands with casters
- Metric fastener mounting hardware included
- For use on all stands with casters and any stands over 72" (1829 mm) tall
- One brace per stand for conveyors up to 24" wide (610 mm)
- Two braces per stand for conveyors over 24" wide (610 mm)

| Part Number | Description |
|-------------|--|
| 39MB-TS | for two-legged H style stands up to 30" tall (762 mm) |
| 39MB-TT | for two-legged H style stands over 30" tall (762 mm) |
| 39MB-PT | for Single Post and Pillar stands over 30" tall (762 mm) |

Common Mount Kit

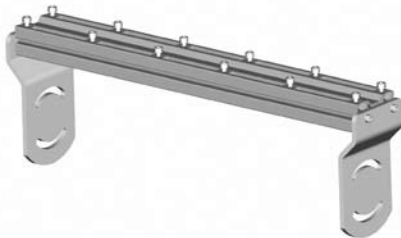

- Stand accessory for mounting multiple conveyors in parallel to one stand
- Adds 2" (51 mm) to stand height
- Adds 2.79" (71 mm) to overall stand width

For ordering information, see page 127

Tall Support Stands



Outriggers

Tall Stands are the Fixed Height and Adjustable Height Stands as shown with additional outrigger support for added stability. These outriggers are required when the height of the stand exceeds 3.5x its width, and they add 16" to stand width. Tall stands over 6' tall include diagonal bracing.

Fine Adjustment Kit

- Provides fine height adjustment via a threaded bolt
- For use with Fixed Height Stands

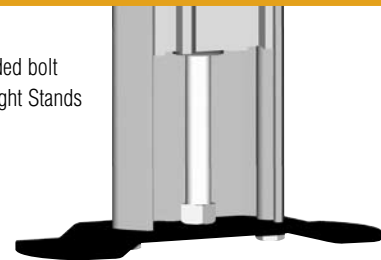

Part # 710028

Note: Due to the wide variety of conveyor and stand options along with possible configurations, stability of the final setup is the responsibility of the end user.

For ordering information, see page 126

QUICK ADJUST STANDS

Fixed Foot Model

| | | | |
|--------------------|----------------------------|---|--------------------------------|
| Stand Width (WW)* | 12" (305mm) | 2" (51mm) increments up to... | 36" (914mm) |
| Part # Reference | 12 | in 02 increments up to... | 36 |
| Stand Height (HH)* | 24" - 30" (610 - 762mm) | in 1" (25mm) increments up to... | 66" - 72" (1,676 - 1,829mm) |
| Part # Reference | 2430 | in 0101 increments up to... | 6672 |

Swivel Locking Caster Model

| | | | |
|--------------------|----------------------------|---|--------------------------------|
| Stand Width (WW)* | 12" (305mm) | 2" (51mm) increments up to... | 36" (914mm) |
| Part # Reference | 12 | in 02 increments up to... | 36 |
| Stand Height (HH)* | 27" - 33" (686 - 838mm) | in 1" (25mm) increments up to... | 60" - 66" (1,524 - 1,676mm) |
| Part # Reference | 2733 | in 0101 increments up to... | 6066 |

* Under 12" wide use full top plate option

- Metric fasteners
- +/- 3" (76 mm) Height Adjustment
- Allows for Quick Height Adjustment
- Tool-less lock and adjustment handles



Fixed Foot Model

Swivel Locking Caster Model

A-FRAME STANDS

Fixed Foot Model

| | | | |
|--------------------------|----------------------------|---|--------------------------------|
| Stand Width (WW) | 3.75" (95mm) | 2" (51mm) increments up to... | 36" (914mm) |
| Part # Reference | 04 | in 02 increments up to... | 36 |
| Top of Belt Height (HH)* | 13" - 17" (330 - 432mm) | in 1" (25mm) increments up to... | 56" - 60" (1,422 - 1,524mm) |
| Part # Reference | 1317 | in 0101 increments up to... | 5660 |

Swivel Locking Caster Model

| | | | |
|--------------------------|----------------------------|---|--------------------------------|
| Stand Width (WW) | 3.75" (95mm) | 2" (51mm) increments up to... | 36" (914mm) |
| Part # Reference | 04 | in 02 increments up to... | 36 |
| Top of Belt Height (HH)* | 18" - 20" (457 - 508mm) | in 1" (25mm) increments up to... | 58" - 60" (1,473 - 1,524mm) |
| Part # Reference | 1820 | in 0101 increments up to... | 5860 |

* From floor to top of belt

- Metric fasteners
- +/- 2" (51 mm) Height Adjustment for Fixed Foot Model
- +/- 1" (25 mm) Height Adjustment for Swivel Locking Caster Model
- One (1) SmartSlot™ per side



Fixed Foot Model

Swivel Locking Caster Model

Note: Dimensions = in (mm)

Note: Due to the wide variety of conveyor and stand options along with possible configurations, stability of the final setup is the responsibility of the end user.

For ordering information, see page 126