

# DORNER® QWIK CONVEYORS 5200 SERIES: Cleated Belt End Drive

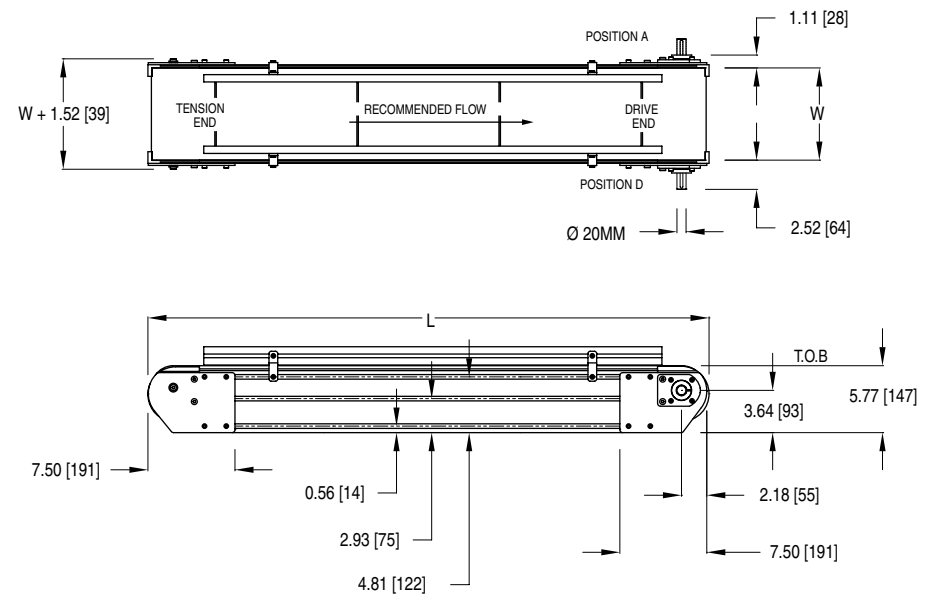

## 5200 Specifications:

- Loads up to 1000 lbs. (455 kg)
- Belt speeds up to 260 ft/min (80 m/min)
- Belt widths: 8" to 24"  
(203mm to 610mm) in 2" increments
- Conveyor lengths: 3' to 999"  
(914mm to 25,375mm) in 1" increments
- UHMW wear strips
- 4.3" diameter drive and idler pulleys
- T-slots for mounting accessories
- Rigid, 5.8" high, anodized aluminum frame
- Available in 1" and 3" high cleats
- Includes anodized aluminum side guides (not shown)

## Features & Benefits:

- QWIK Slots™ make mounting air and electrical lines simple with no drilling, special tools or t-nuts required
- Completely contained belt eliminates catenary sag and reduces pinch points
- Designed-in low voltage wireway provides support and protection for low voltage wires running from the electronic device to the main junction or control box
- No holes in side rails makes reconfiguration quick and easy
- Open top frame simplifies belt maintenance and replacement
- Sprocket alignment key provides continuous sprocket alignment for quick belt assembly
- Support stands mount directly to bottom of side rail which keeps frame open for mounting accessories

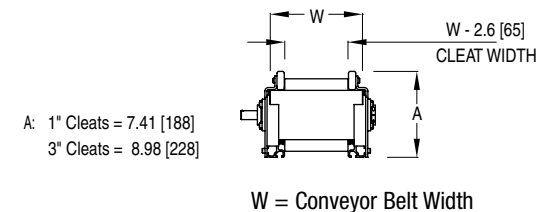

Conveyor load capacity depends on conveyor size, incline, motor position, accumulated loads and other factors.