

DORNER® AquaGard™ 7350 SERIES: Straight Modular Plastic Belt

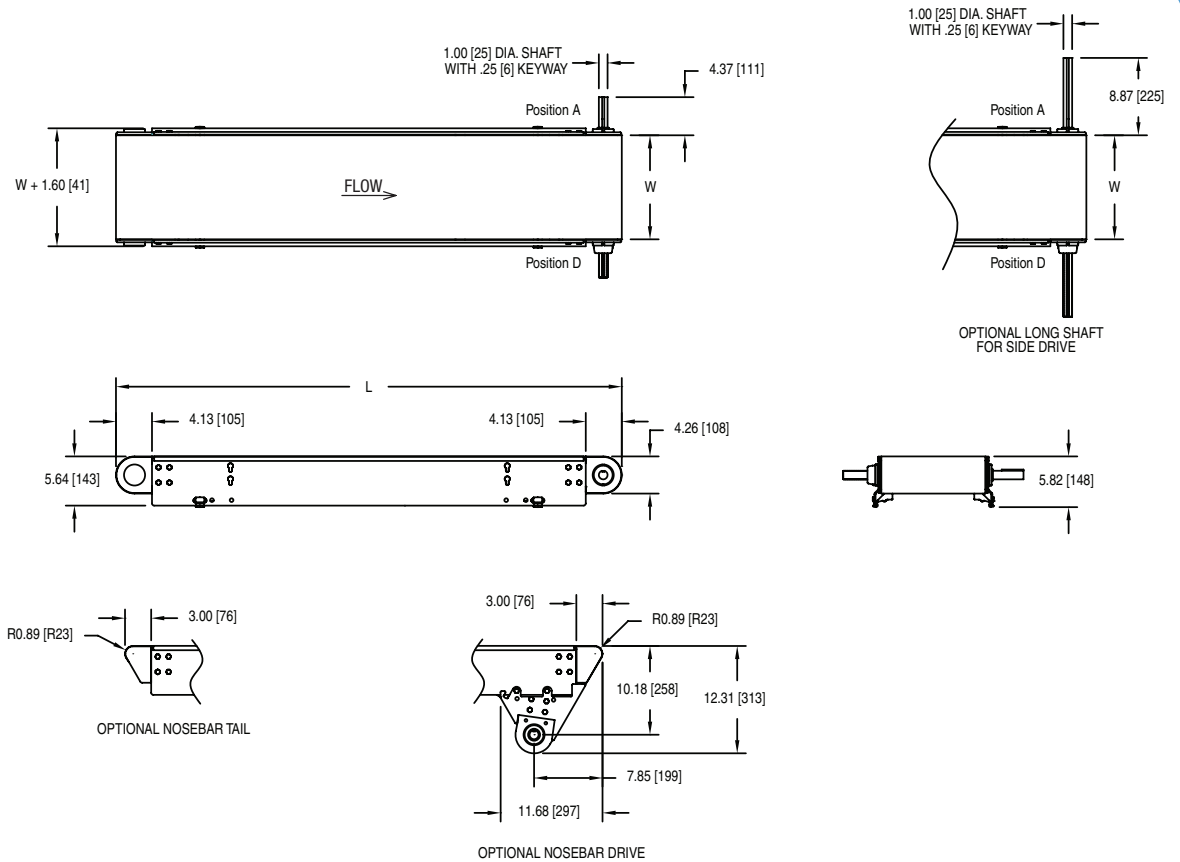
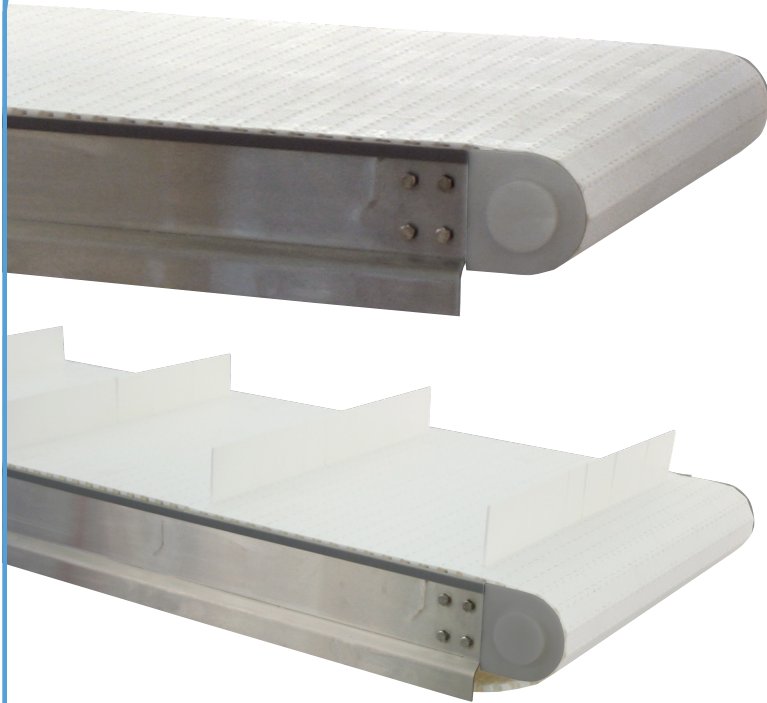

7350 Specifications:

- Flat Belt Widths:
4" to 36" (102mm to 914mm)
- Cleated Belt Widths:
4" to 24" (102mm to 610mm)
- Total Lengths:
3' up to 83' (914mm to 25.4m)
- Loads up to 20 lbs/square foot of belt (90 kg/m²)
- Belt speeds up to 260 ft/min (78.6 meters/min)

Features & Benefits:

- Frame is constructed of TIG welded 304 stainless steel and features open design with minimal horizontal surfaces.
- Solid UHMW wear strips located in welded cross members for durable belt support.
- Mount controls and accessories fast with no drilling required includes adjustable guiding, photo eyes, low voltage wires, controls, and air tubing.
- Flexible guiding packages for a variety of applications including fully adjustable single and twin rail, and high side.
- Conveyor is suitable for wipe-down and occasional pressurized liquid spray cleaning up to 100 psi.

Conveyor load capacity depends on conveyor size, incline, motor position, accumulated loads and other factors.