

Sidewall Cleated Belt

C= 6.74 [171] for W or Y cleats  
7.53 [191] for X or Z cleats

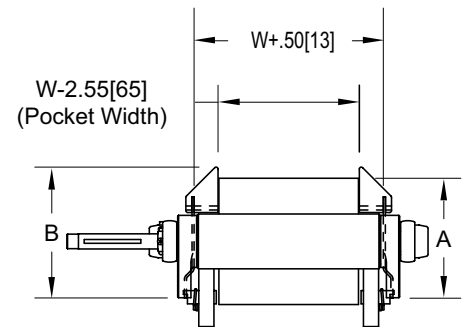
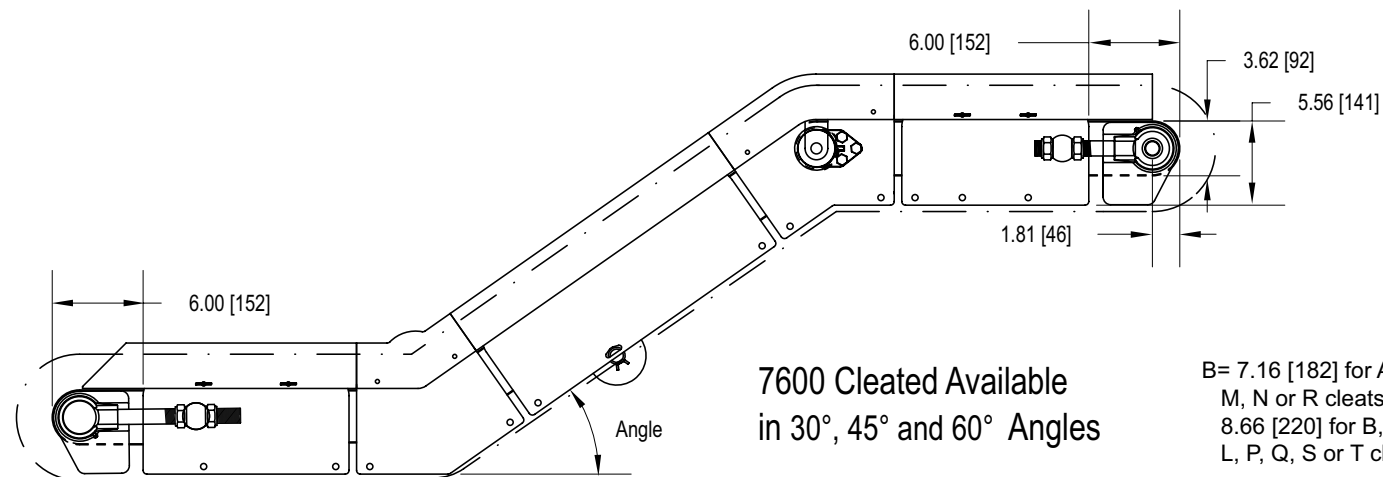

B= 7.16 [182] for A, G, J, M, N or R cleats  
8.66 [220] for B, C, K, L, P, Q, S or T cleats

A= 6.56 [167] for A or J cleats  
7.13 [181] for B, K, P or S cleats  
7.92 [201] for C, L, Q or T cleats  
5.99 [152] for G or M cleats  
6.35 [161] for N or R cleats