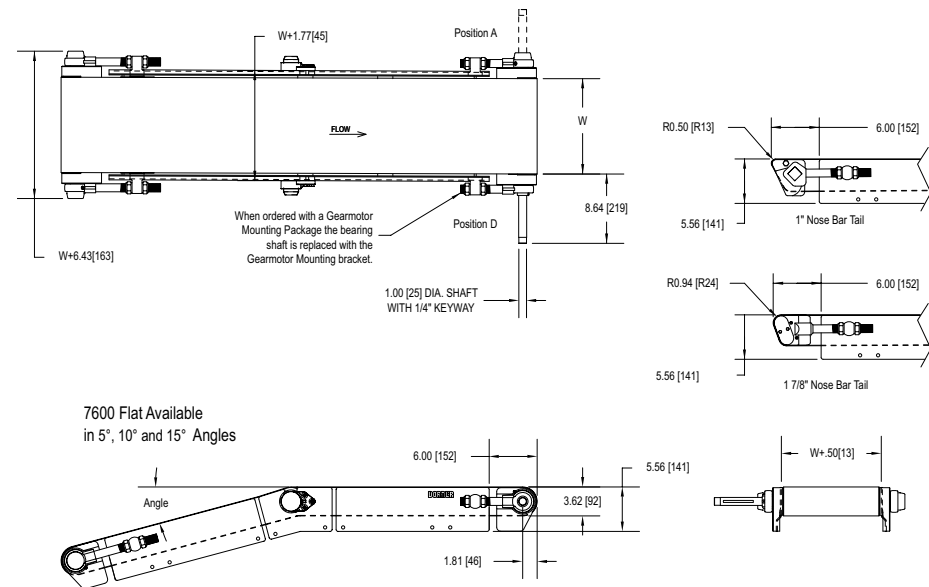

**DORNER**<sup>®</sup>**AquaPruf<sup>®</sup> 7600 SERIES: LPZ Flat Belt End Drive Conveyor****Specifications:**

- Belt Widths: 6" to 24" (152mm to 610mm)
- Section Lengths 24" (610mm) to 38" (11.6m)
- Total Conveyor Lengths to 40' (12.2m)
- Loads up to 20 lbs. per square foot of belt (90 Kg/m<sup>2</sup>)
- Belt Speed: 233 ft/min maximum (71 M/min)
- 5°, 10° & 15° Fixed Angle Modules standards
- Nose-Over configurations
- Continuous TIG Welded 304 stainless steel frame
- #4 Polish on all outside surfaces
- Bearing material is 400 stainless steel
- Bearing lubricant is H1 type FDA lubricant
- 3.5" (88.9mm) diameter drive roller with cast-on Urethane lagging
- UHMW Wear strip bed plate
- FDA Approved belting and plastic components

**Features & Benefits:**

- Frame is constructed of continuous TIG welded 304 stainless steel and is designed with minimal horizontal surfaces for optimum cleaning. Conveyors over 10' (3048mm) consist of multiple sections which are bolted together.
- All bearings are 400 stainless steel, filled with H1 FDA lubricant and mounted in cast stainless steel housings for maximum performance in washdown environments.
- Solid bed plate (optional) is stainless steel and locates on UHMW strips for delicate / fragile products.
- Belt tensioning mechanism is constructed of 304 stainless steel and uses Acme threads for easy cleaning. Externally mounted to the frame with adequate clearances for cleaning.
- Conveyor is designed to withstand high pressure (100-1500 PSI) spray and chlorinated solutions.
- Frame cut-outs (optional) are available to allow spraying the inside of the conveyor without lifting the belt.
- Return Belt Supports are 4" UHMW Rollers and are easily removed without tools for effective cleaning.
- Drive spindle is 3.5" diameter stainless steel with Cast-On Urethane Lagging for increased load capacity. Spindle has groove for V-guided belts for optimum performance.
- The tool-less tip up pulley allows conveyor end to be lifted easily for quick access to inside of conveyor for cleaning.
- Belt lifters (optional) lift belt from wear strips/bed plate by simply pulling an external lever for fast access and effective cleaning.
- Belt scraper (optional) removes build up and adjusts easily for each application. Features tool-less dis-assembly/assembly for cleaning of parts.

Conveyor load capacity depends on conveyor size, incline, motor position, accumulated loads and other factors.

**DORNER**<sup>®</sup>  
Performance in motion

DORNER MFG. CORP.  
PO Box 20 • 975 Cottonwood Ave  
Hartland, WI 53029-0020 USA

INSIDE THE USA  
TEL: 800.397.8664  
FAX: 800.369.2440

OUTSIDE THE USA  
TEL: 262.367.7600  
FAX: 262.367.5827

[www.dorner.com](http://www.dorner.com)  
[info@dorner.com](mailto:info@dorner.com)