



7350 Series End Drive Conveyors

Installation, Maintenance and Parts Manual



DORNER MFG. CORP.
P.O. Box 20 • 975 Cottonwood Ave.
Hartland, WI 53029-0020 USA

INSIDE THE USA
TEL: 1-800-397-8664
FAX: 1-800-369-2440

OUTSIDE THE USA
TEL: 262-367-7600
FAX: 262-367-5827

For other service manuals visit our website at:
www.dorner.com/service_manuals.asp

Table of Contents

| | | | |
|---|----|--|----|
| Introduction | 2 | Conveyor Belt Tensioning..... | 14 |
| Warnings – General Safety..... | 3 | Wear Strips | 15 |
| Product Description | 4 | Bar Cap Replacement | 15 |
| Specifications | 4 | Wear Strip Removal..... | 15 |
| Flat Belt 7350 Series Conveyor | 4 | Drive Sprocket and Spindle Replacement..... | 15 |
| Cleated Belt 7350 Series Conveyor | 4 | Idler Puck and Spindle Replacement..... | 17 |
| 7350 Series Z-Frame Conveyor Modules | 5 | Nose Bar Idler Spindle Replacement | 18 |
| 7350 Series Infeed Section to Knuckle | 5 | Bearing Replacement | 19 |
| 7350 Series Mid Section between two Knuckles | 5 | Drive Bearing Removal and Replacement..... | 19 |
| 7350 Series Mid Section between Knuckle and Curve | 5 | Idler Bearing Removal and Replacement | 19 |
| 7350 Series Discharge Section from Knuckle..... | 5 | Maintenance of Knuckles | 19 |
| Conveyor Supports | 6 | Lower Knuckle | 19 |
| Specifications..... | 6 | Upper Knuckle | 20 |
| Installation | 7 | Service Parts..... | 22 |
| Required Tools..... | 7 | Drive End Components | 22 |
| Recommended Installation Sequence | 7 | Idler End Components..... | 24 |
| Conveyors Longer than 10 ft (3048 mm) | 7 | Nose Bar Idler End Components..... | 25 |
| Connecting Components | 7 | Frame Assembly..... | 26 |
| Z-Frame Conveyors | 8 | Upper Knuckle | 27 |
| Knuckles..... | 8 | Lower Knuckle | 28 |
| Upper Knuckle..... | 8 | Connecting Assembly..... | 29 |
| Lower Knuckle | 8 | 1" (25 mm) High Sides..... | 30 |
| All Conveyors | 9 | 3" (76 mm) High Sides..... | 31 |
| Stand Installation..... | 9 | Fully Adjustable Round Guides | 32 |
| Belt Installation..... | 9 | Tool-Less Fully Adjustable Round Guides | 33 |
| Belt Returns | 10 | Twin Rail Adjustable Round Guides..... | 34 |
| Returns for conveyors up to 24" wide..... | 10 | Tool-Less Twin Rail Adjustable Round Guides | 35 |
| Returns for conveyors 26" - 36" wide | 11 | Fully Adjustable 1" (25 mm) Flat Guides | 36 |
| Guide Installation..... | 12 | Tool-Less Fully Adjustable 1" (25 mm) Flat Guides..... | 37 |
| Drive Package Installation | 12 | 1" (25 mm) Cleated High Sides..... | 38 |
| Preventive Maintenance and Adjustment | 13 | 3" (76 mm) Cleated High Sides..... | 39 |
| Required Tools..... | 13 | 4" (102 mm) - 24" (610 mm) Wide Returns..... | 40 |
| Checklist | 13 | 26" (660 mm) - 36" (914 mm) Wide Returns..... | 40 |
| Cleaning | 13 | Ordering a Replacement Chain | 41 |
| Lubrication..... | 13 | Flat Belt Chain Repair Kit..... | 41 |
| Maintaining the Conveyor Belt..... | 13 | Cleated Belt Chain Repair Kit..... | 41 |
| Troubleshooting | 13 | Return Policy..... | 42 |
| Conveyor Belt Replacement | 14 | | |

Introduction

CAUTION

Some illustrations may show guards removed. DO NOT operate equipment without guards.

Upon receipt of shipment:

- Compare shipment with packing slip. Contact factory regarding discrepancies.
- Inspect packages for shipping damage. Contact carrier regarding damage. Accessories may be shipped loose.
- See accessory instructions for installation.

The Dorner Limited Warranty applies.

Dorner 7350 Series conveyors have patents pending.

Dorner reserves the right to make changes at any time without notice or obligation.

Dorner has convenient, pre-configured kits of Key Service Parts for all conveyor products. These time saving kits are easy to order, designed for fast installation, and guarantee you will have what you need when you need it. Key Parts and Kits are marked in the Service Parts section of this manual with the Performance Parts Kits logo .

Warnings – General Safety

⚠ DANGER



SEVERE HAZARD!
KEEP OFF CONVEYORS. Climbing, sitting, walking or riding on conveyor will result in death or serious injury.

⚠ DANGER



EXPLOSION HAZARD!

- **DO NOT OPERATE CONVEYORS IN AN EXPLOSIVE ENVIRONMENT.** The electric gearmotor generates heat and could ignite combustible vapors.
- Failure to comply will result in death or serious injury.

⚠ WARNING



CRUSH HAZARD!

- **DO NOT** place hands or fingers inside the conveyor while it is running.
- **DO NOT** wear loose garments while operating the conveyor. Loose garments can become caught up in the conveyor.
- Failure to comply could result in serious injury.

⚠ WARNING



CRUSH HAZARD!

- **SUPPORT CONVEYOR SECTIONS PRIOR TO LOOSENING STAND HEIGHT OR ANGLE ADJUSTMENT SCREWS.**
- Loosening stand height or angle adjustment screws may cause conveyor sections to drop down, causing serious injury.

⚠ WARNING



SEVERE HAZARD!
LOCK OUT POWER before removing guards or performing maintenance. Exposed moving parts can cause serious injury.

⚠ WARNING



BURN HAZARD!
DO NOT TOUCH the motor while operating, or shortly after being turned off. Motors may be **HOT** and can cause serious burn injuries.

⚠ WARNING



PUNCTURE HAZARD!
 Handle drive shaft keyway with care. It may be sharp and could puncture the skin, causing serious injury.

⚠ WARNING



SEVERE HAZARD!

- Dorner cannot control the physical installation and application of conveyors. Taking protective measures is the responsibility of the user.
- When conveyors are used in conjunction with other equipment or as part of a multiple conveyor system, **CHECK FOR POTENTIAL PINCH POINTS** and other mechanical hazards before system start-up.
- Failure to comply could result in serious injury.

Product Description

Refer to (Figure 1) for typical conveyor components.

| Typical Components | |
|--------------------|---------------------------|
| 1 | Conveyor |
| 2 | Gearmotor |
| 3 | Belt (Cleated Belt Shown) |
| 4 | Support Stands |
| 5 | Drive End |
| 6 | Idler End |

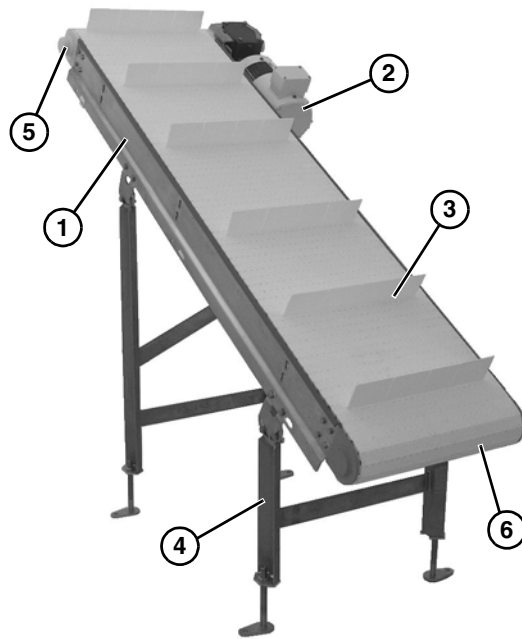
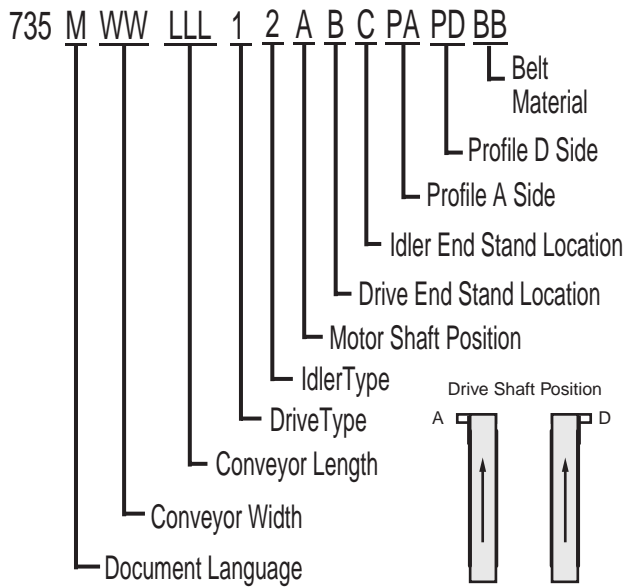

Figure 1

Specifications

Flat Belt 7350 Series Conveyor



Cleated Belt 7350 Series Conveyor

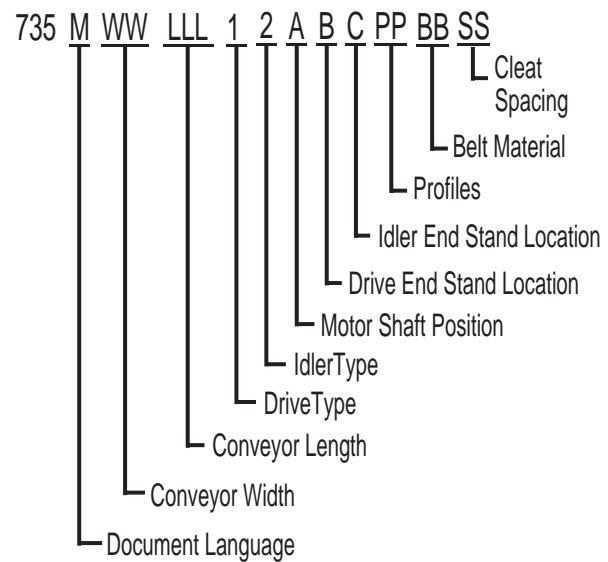

7350 Series Z-Frame Conveyor Modules

7350 Series Infeed Section to Knuckle

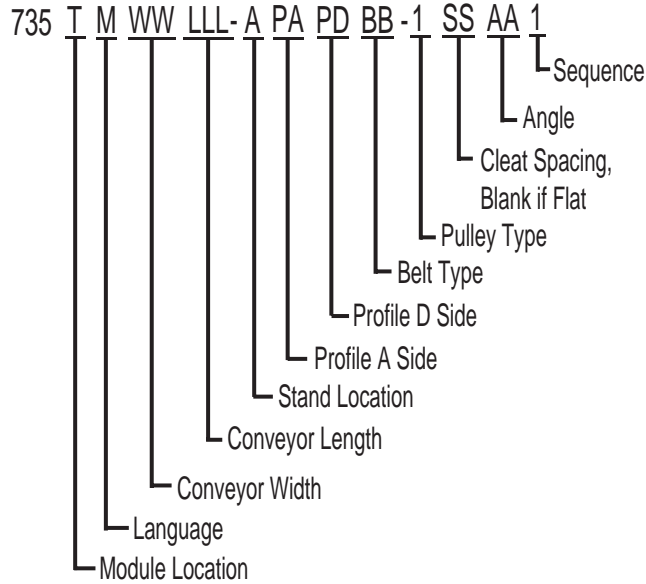

7350 Series Mid Section between Knuckle and Curve

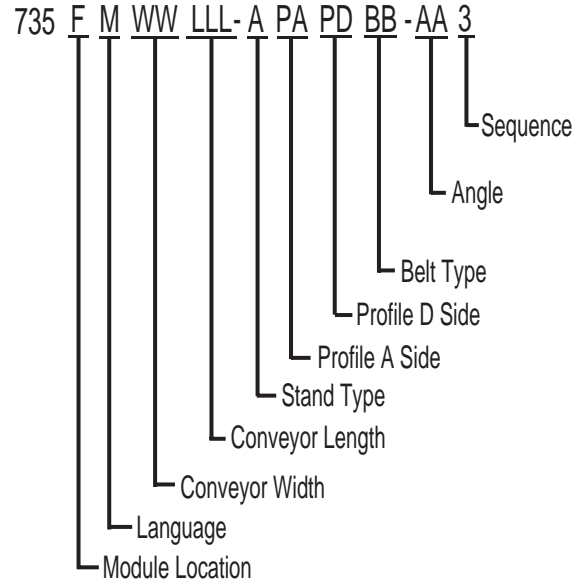

7350 Series Mid Section between two Knuckles

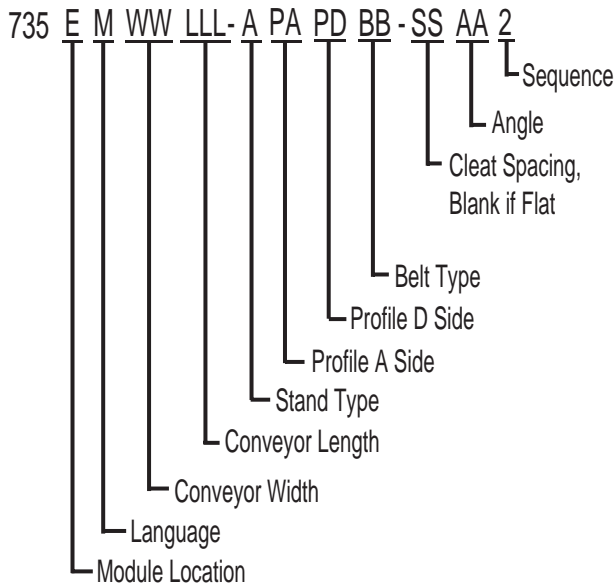

7350 Series Discharge Section from Knuckle

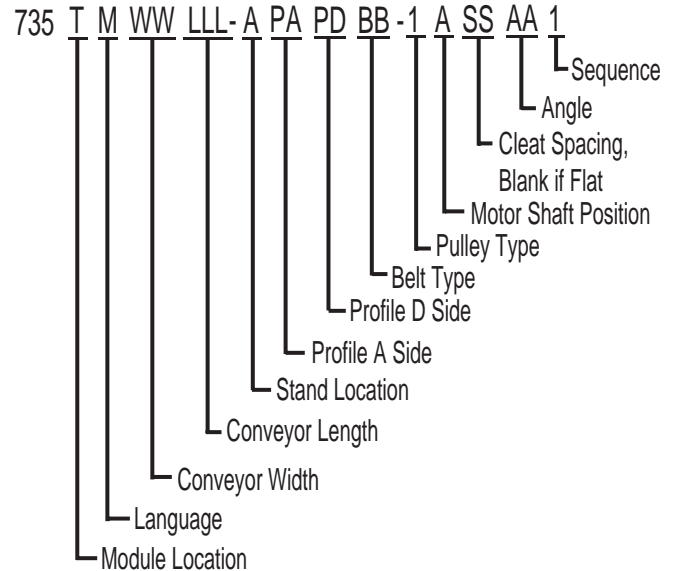

Specifications

Conveyor Supports

Maximum Distances:

- 1 = Support Stand on Idler End = 30" (762 mm)
 - 2 = Between Support Stands = 8 ft (2438 mm)**
 - 3 = Support Stand on Drive End = 24" (610 mm)
- ** For conveyors longer than 10 ft (3048 mm),
install stand mount kit at frame joint.

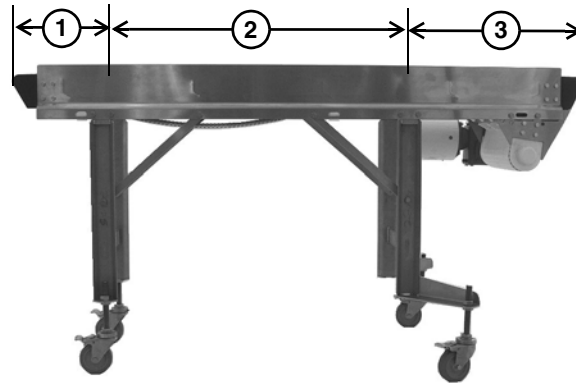

Figure 2

Specifications

| | |
|--|--|
| Conveyor Width Reference (<u>WW</u>) | 04 – 36 in 02 increments |
| Conveyor Belt Width | 4" (102 mm) - 36" (914 mm) in 2" (51 mm) increments |
| Maximum Conveyor Load | 20 lbs. / ft ² (97 kg/ m ²) with a maximum of 750 lbs. (340 kg) |
| Belt Travel | 12" (305 mm) per revolution of pulley |
| Maximum Belt Speed | 260 ft/minute (79 m/minute) |

| | |
|--|---|
| Conveyor Length Reference (<u>LLL</u>) | 036 – 999 in 001 increments |
| Conveyor Length | 36" (914 mm) - 999" (25.4 m) in 1" (25 mm) increments |

IMPORTANT

Maximum conveyor loads are based on:

- *Non-accumulating product*
- *Product moving toward gearmotor*
- *Conveyor being mounted horizontally*
- *Conveyor being located in a dry environment*
- *Conveyor equipped with standard belt only*

CAUTION

Conveyor **MUST** be mounted straight, flat and level within confines of conveyor. Use a level (Figure 3, item 1) during setup.

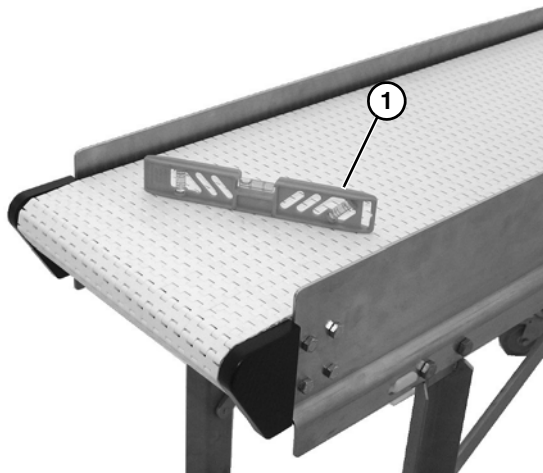

Figure 3

Required Tools

- Level
- Torque wrench
- 5/32" hex wrench (for bearings)
- 13 mm wrench (for tail assemblies)
- 14 mm wrench (for motor mounts)
- 17 mm wrench (for stands)

Recommended Installation Sequence

1. Assemble the conveyor (if required). Refer to "Conveyors Longer than 10 ft (3048 mm)" on page 7.
2. Attach the stands. Refer to "Stand Installation" on page 9.
3. Install the belt. Refer to "Belt Installation" on page 9.
4. Install the gearmotor. Refer to "Drive Package Installation" on page 12.

Conveyors Longer than 10 ft (3048 mm)

Connecting Components

Typical Connecting Components (Figure 4).

- | | |
|---|---|
| 1 | Connector Plate (x2) |
| 2 | Hex Head Cap Screw M10-1.50 x 12mm (x4) |
| 3 | Conveyor Frames |

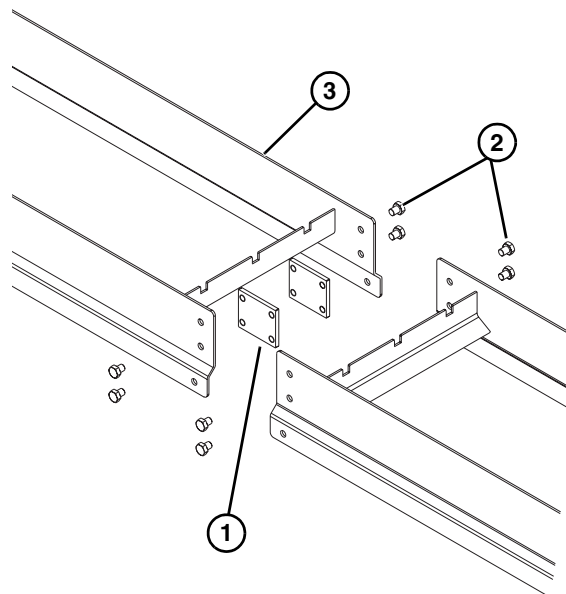

Figure 4

1. Join both conveyor sections, and install plate frame connectors (Figure 4, item 1), and secure with M10x12 hex head cap screws (Figure 4, item 2) on both sides.

Installation

Z-Frame Conveyors

NOTE

Be sure all frame sections are properly supported during Z-Frame assembly.

Knuckles

Upper Knuckle

1. Attach upper knuckle (**Figure 5, item 1**) to frame (**Figure 5, item 2**) by using two cap screws (**Figure 5, item 3**) and connector plate (**Figure 6, item 1**) on each side of conveyor.

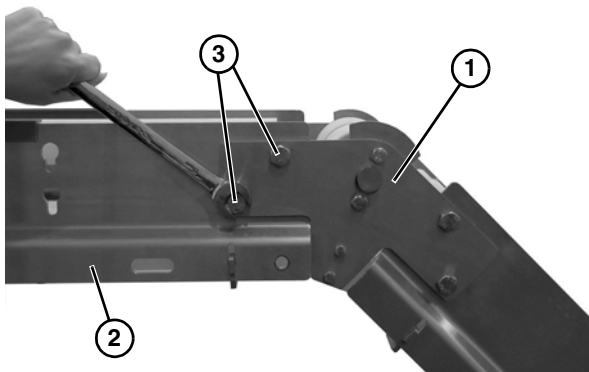

Figure 5

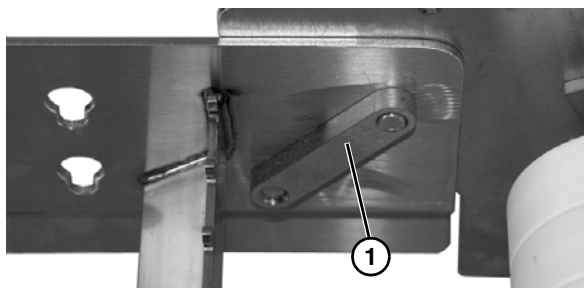

Figure 6

2. Attach bar cap (**Figure 7, item 1**) to frame and knuckle.

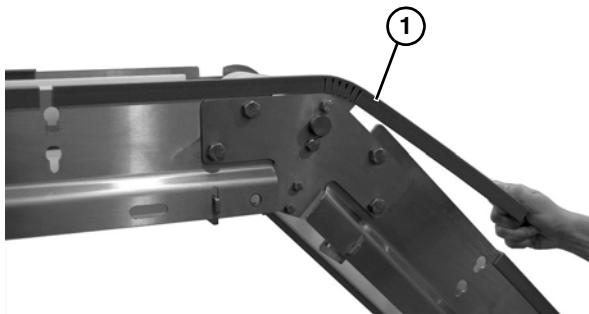

Figure 7

3. Tighten all cap screws to 60 in-lb (7 Nm).

Lower Knuckle

1. Attach lower knuckle (**Figure 8, item 1**) to frame (**Figure 8, item 2**) by using two cap screws (**Figure 8, item 3**) and connector plate (**Figure 9, item 1**) on each side of conveyor.

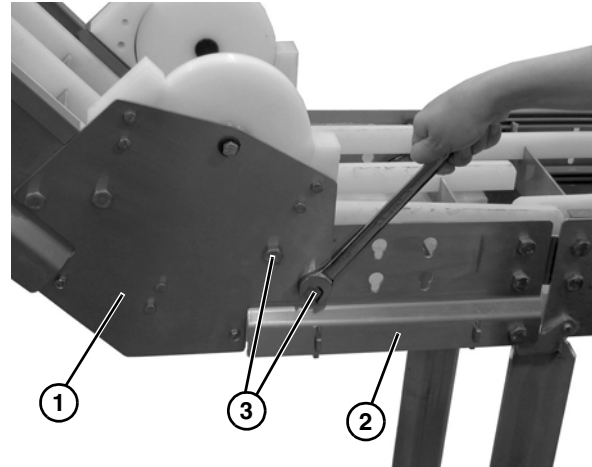

Figure 8

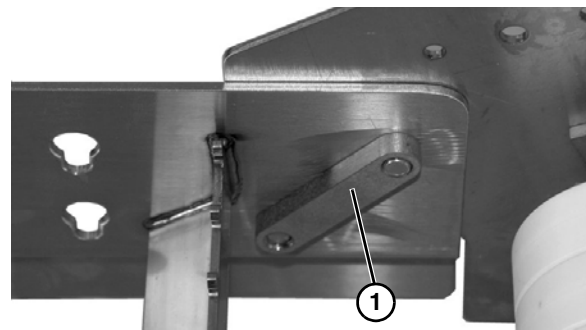

Figure 9

2. Tighten all cap screws to 60 in-lb (7 Nm).

All Conveyors

Stand Installation

NOTE

For detailed assembly instructions, please see support stand manual 851-683.

Typical stand components (Figure 10)

- | | |
|---|--|
| 1 | Conveyor Frame |
| 2 | Stand |
| 3 | M10 - 1.5 x 16 mm hex head cap screws (x4) |

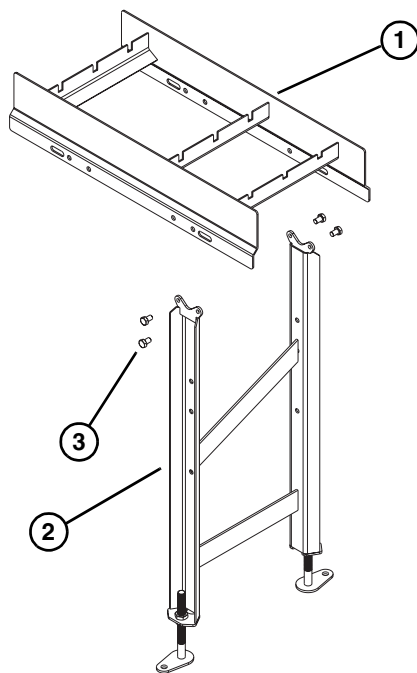

Figure 10

1. Position the stands on a flat, level surface.
2. Attach the stands to the frame (Figure 11, item 1).

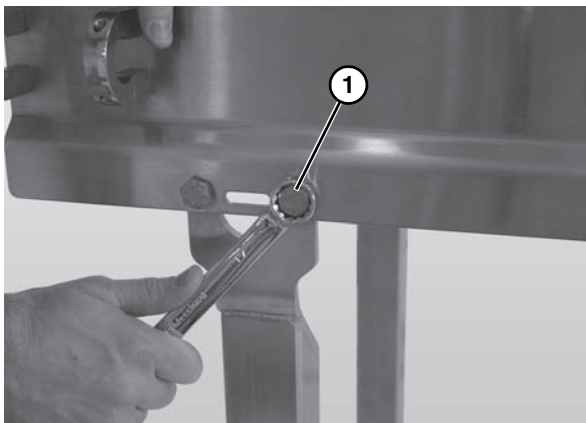

Figure 11

Belt Installation

Typical Belt Components (Figure 12)

- | | |
|---|------------|
| 1 | Chain Belt |
| 2 | Belt Rod |

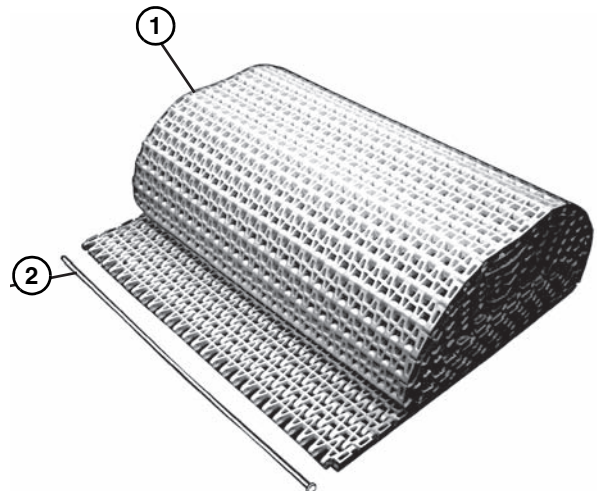

Figure 12

1. Position the belt on the conveyor frame (Figure 13).



Figure 13

2. Wrap belt around idler tail.

Installation

3. Wrap the belt around the drive end of the conveyor, making sure the sprocket teeth have engaged the belt, with concave teeth (**Figure 14, item 1**) mating with rounded section (**Figure 14, item 2**) of belt.

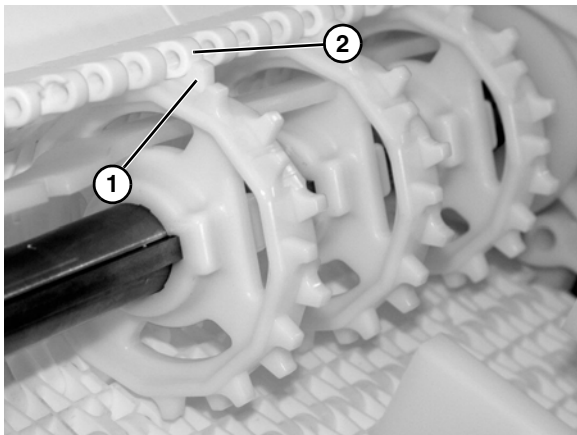

Figure 14

4. For Z-Frame conveyors, guide the belt under the hold down guides (**Figure 15, item 1**) in the lower knuckle.

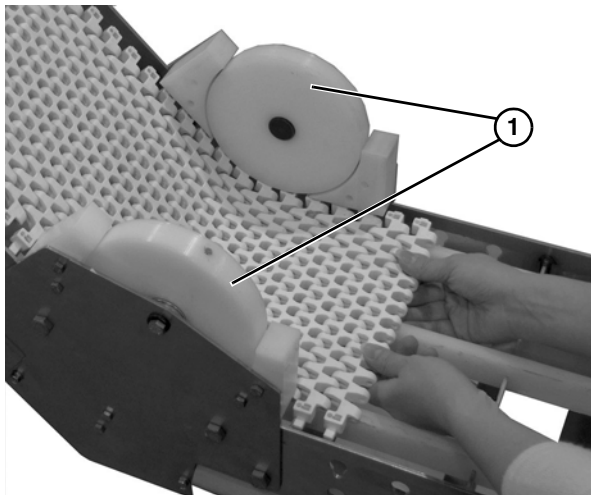

Figure 15

5. Bring the ends of the belt together (**Figure 16**).



Figure 16

6. Insert the belt rod (**Figure 17, item 1**).

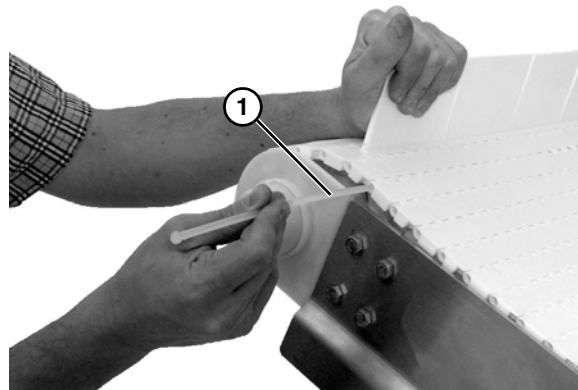

Figure 17

7. Push the belt rod in as far as possible.
8. Lightly tap the head of the rod with a hammer until it snaps into position.

Belt Returns

Returns for conveyors up to 24" wide

1. Install belt return (**Figure 18, item 1**) into slotted frame hole (**Figure 18, item 2**).

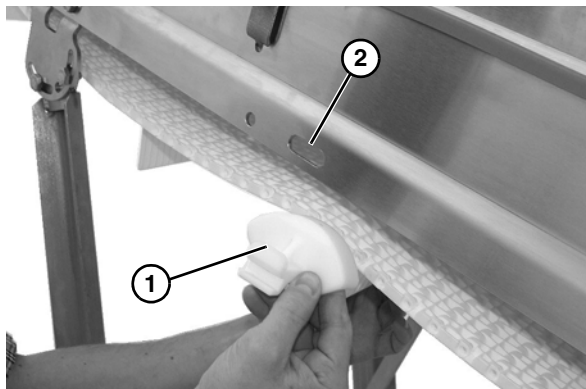

Figure 18

2. Install belt (Figure 19, item 1) around lower frame section and above lower wear strip (Figure 19, item 2).

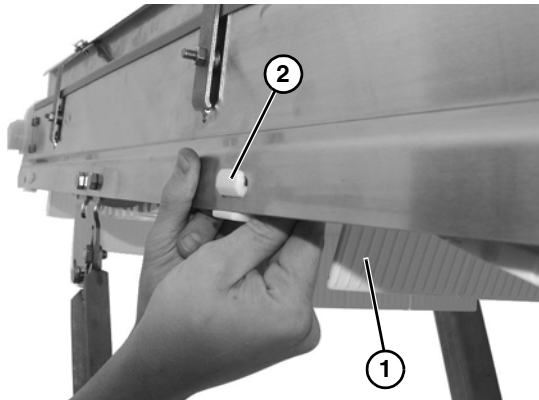

Figure 19

1. Check belt sag by measuring from the bottom of conveyor frame (Figure 20). Belt sag should not exceed 2" (51 mm).

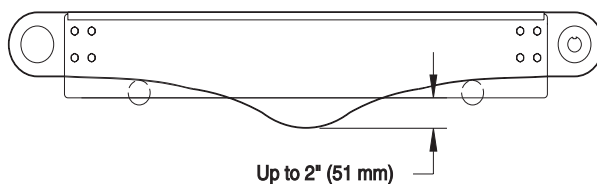

Figure 20

CAUTION

Belt sag should not exceed 2" (51 mm) from the bottom of the conveyor frame.

Returns for conveyors 26" - 36" wide

1. Install belt return mounting bracket (Figure 21, item 1) into slotted frame hole (Figure 21, item 2).

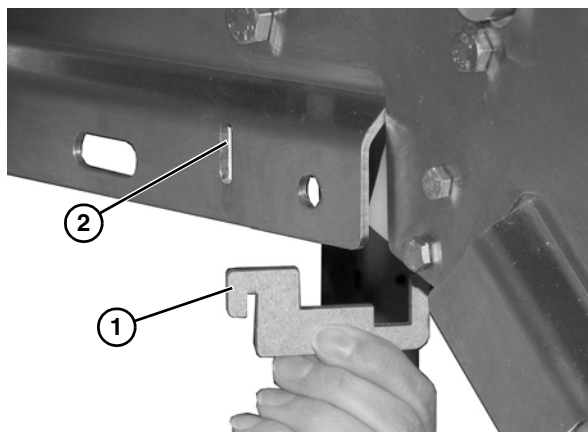

Figure 21

2. Install belt return (Figure 22, item 1) onto mounting bracket (Figure 22, item 2).

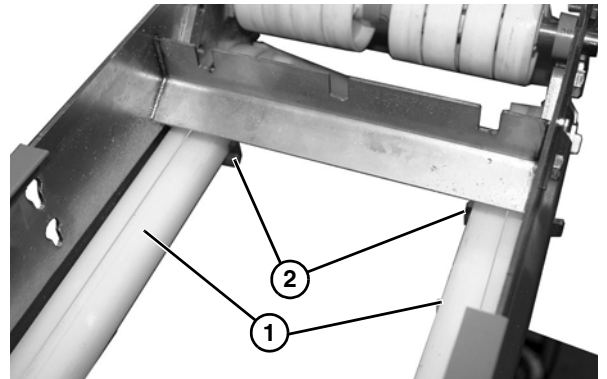

Figure 22

3. Verify that belt returns are mounted correctly by following graphic below (Figure 23) shows incorrect mounting and (Figure 24) shows correct mounting.

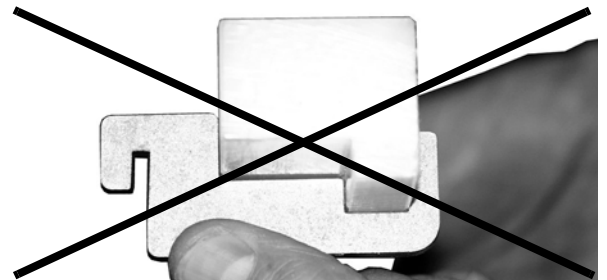

Figure 23

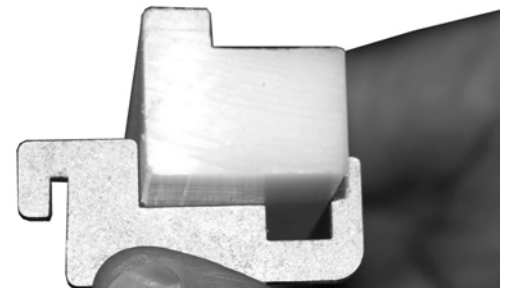

Figure 24

Installation

Guide Installation

1. Insert carriage bolts with spacers (**Figure 25, item 1**) into slotted holes in conveyor side.

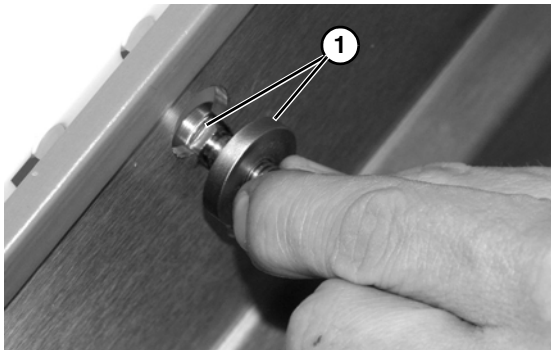

Figure 25

2. Attach the guide mounting brackets (**Figure 26, item 1**) to the conveyor with hex nuts (**Figure 26, item 2**). Hand tighten only at this time.

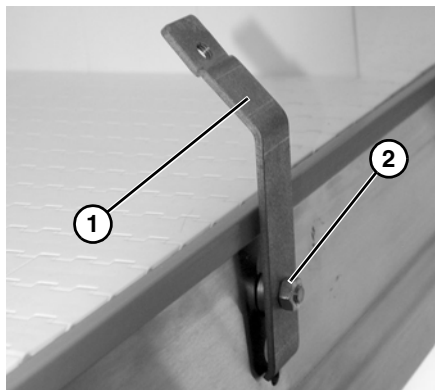

Figure 26

3. Attach guide (**Figure 27, item 1**) to the mounting brackets with hex bolts and spacers (**Figure 27, item 2**). Hand tighten only at this time.

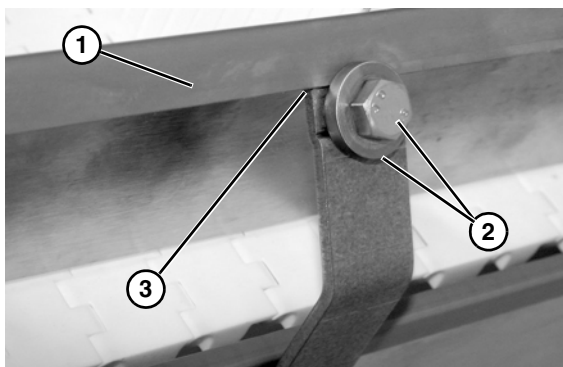

Figure 27

4. Ensure that nose of bracket slips under the lip of guide (**Figure 27, item 3**).

NOTE

*When installing guides, be sure that the angled end of guide is installed on the idler end of conveyor (**Figure 28, item 1**).*

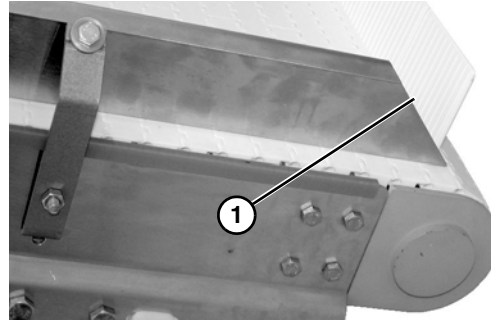

Figure 28

5. Tighten all mounting hardware.

Drive Package Installation

For detailed assembly instructions, refer to the appropriate Drive Packages Manual:

- 851-679 Side Mount 90° Drive Package
- 851-681 Bottom Mount 90° Drive Package
- 851-682 Bottom Mount Parallel Shaft Drive Package

1. Attach the motor (**Figure 29, item 1**) to the gear reducer (**Figure 29, item 2**).

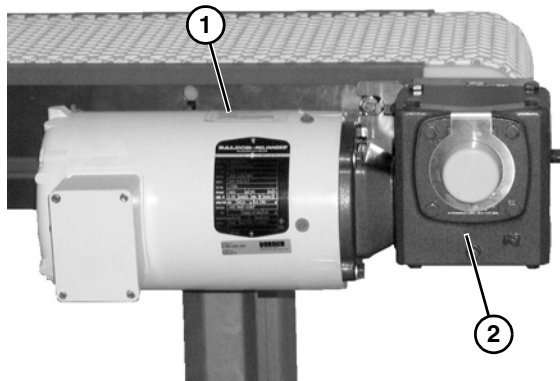

Figure 29

Preventive Maintenance and Adjustment

Required Tools

- 4 mm hex wrench
- 5 mm hex wrench
- 6 mm hex wrench
- 8 mm hex wrench
- Punch and hammer (to remove belt rod)

Checklist

- Keep service parts on hand. Refer to the "Service Parts" section starting on page 22 for recommendations.
- Replace any worn or damaged parts.

Cleaning

| NOTE |
|--|
| <i>Proper conveyor application, cleaning, and sanitation are the responsibility of the end user.</i> |

| CAUTION |
|---|
| Dorner recommends cleaning all the "food zones" prior to placing conveyor into service. Ensure adequate access is provided for cleaning and servicing equipment so that the required level of hygiene can be maintained. |

|  WARNING |
|---|
|  |
| SEVERE HAZARD! LOCK OUT POWER before removing guards or performing maintenance. Exposed moving parts can cause serious injury. |

Lubrication

No lubrication is required. Replace bearings if worn.

Maintaining the Conveyor Belt

Troubleshooting

| NOTE |
|---|
| <i>Visit www.dorner.com for complete list of troubleshooting solutions.</i> |

Inspect conveyor belt for:

- Surface cuts or wear
- Skipping

Damage to belt links or rods, surface cuts and / or wear indicate:

- Sharp or heavy parts impacting belt
- Jammed parts
- Accumulated dirt
- Foreign material inside the conveyor
- Improperly positioned accessories

Skipping indicates:

- Excessive load on belt
- Worn spindle or impacted dirt on drive spindle

Preventive Maintenance and Adjustment

Conveyor Belt Replacement

| |
|--|
| ⚠ WARNING |
|  |
| SEVERE HAZARD! LOCK OUT POWER before removing guards or performing maintenance. Exposed moving parts can cause serious injury. |

1. Remove guides (Figure 30, item 1) when required.

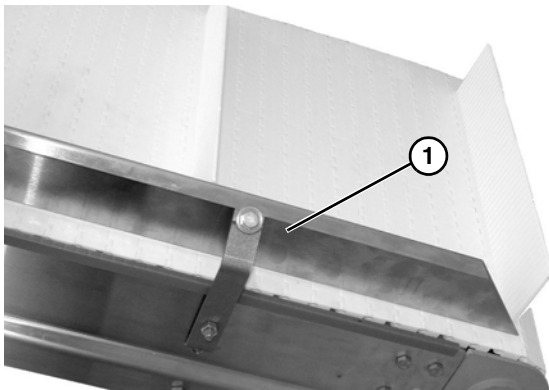

Figure 30

2. Use a punch and hammer to push the belt rod out by striking the rod end opposite the retaining head (Figure 31).



Figure 31

3. Slide the old belt off the conveyor frame.
4. Replace the old belt with a new one. Refer to "Belt Installation" on page 9.

| |
|---|
| CAUTION |
| DO NOT reuse belt rods that are damaged or show signs of wear. |

Conveyor Belt Tensioning

| |
|--|
| ⚠ WARNING |
|  |
| SEVERE HAZARD! LOCK OUT POWER before removing guards or performing maintenance. Exposed moving parts can cause serious injury. |

| |
|--|
| NOTE |
| <i>Belt should not be stretched during installation. A proper length of belt can be installed by interlocking the ends by hand without excess links.</i> |

1. Remove one or more belt links to take up tension.

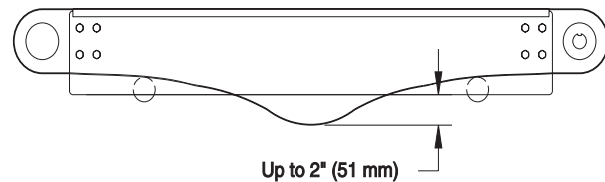

Figure 32

| |
|---|
| CAUTION |
| Belt sag should not exceed 2" (51 mm) from the bottom of the conveyor frame (Figure 32). |

Preventive Maintenance and Adjustment

Wear Strips

Replace the wear strips if they become worn.

Typical Standard Wear Strips (Figure 33)

- | | |
|---|------------------------|
| 1 | Bar Cap |
| 2 | Wear Strips, Bed Frame |

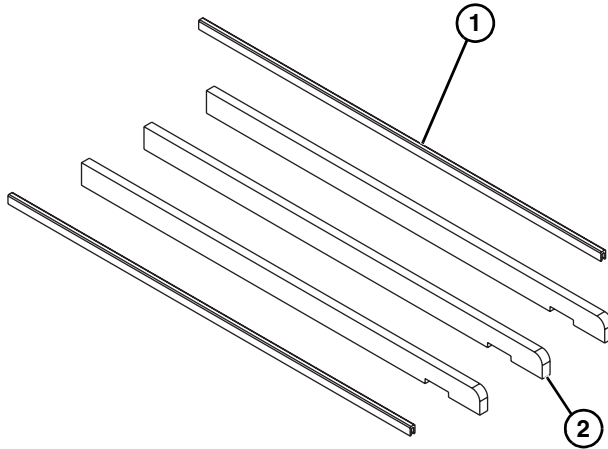

Figure 33

Bar Cap Replacement

1. Remove worn bar cap (Figure 34, item 1) by lifting off of conveyor side rail.

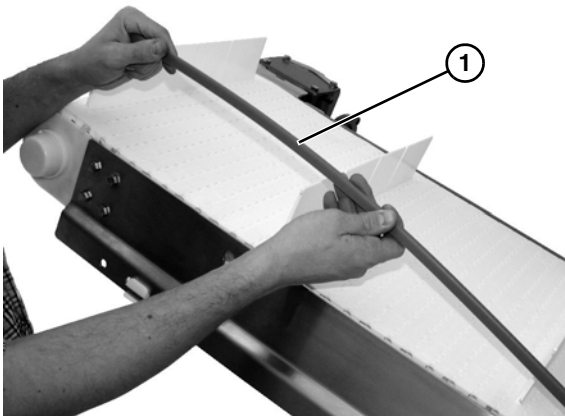

Figure 34

2. Replace with new bar cap.

Wear Strip Removal

1. Remove conveyor belt. See “Conveyor Belt Replacement” on page 14.
2. Remove worn wear strips (Figure 35, item 1) from frame notches.

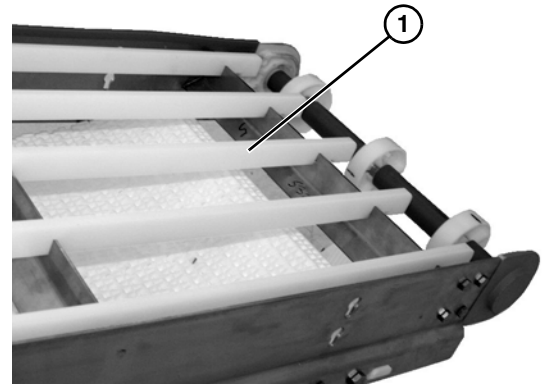

Figure 35

3. Replace with new wear strips.

Drive Sprocket and Spindle Replacement

| |
|--|
|  WARNING |
|  |
| SEVERE HAZARD! Exposed moving parts can cause severe injury. LOCK OUT POWER before removing guards or performing maintenance. |

1. Remove the gearmotor. For detailed instructions, refer to the appropriate drive package manual.
2. Open conveyor belt. See “Conveyor Belt Replacement” on page 14.
3. Remove bearing cover (Figure 36, item 1).

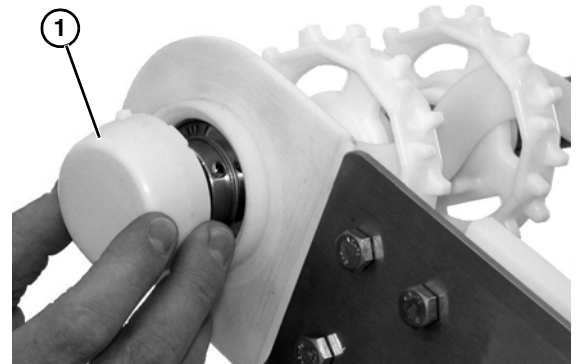

Figure 36

Preventive Maintenance and Adjustment

4. Remove the four head plate bolts (Figure 37, item 1) on both sides of the conveyor.

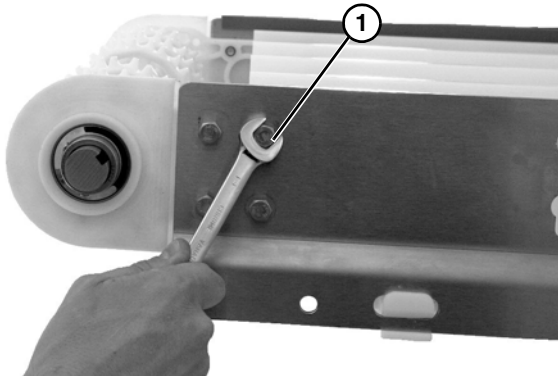

Figure 37

5. Remove tail assembly.
6. Loosen set screws (Figure 38, item 1).

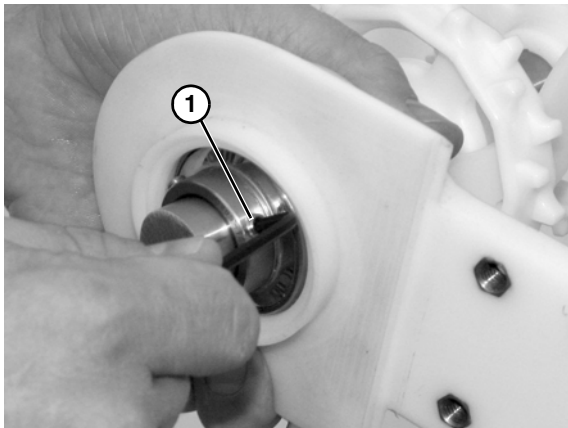

Figure 38

7. Slide the head plate with bearing (Figure 39, item 1) off the shaft.

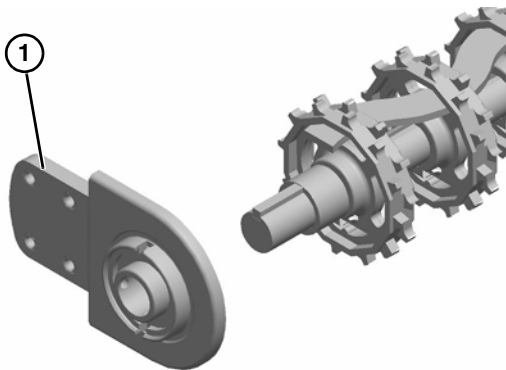

Figure 39

8. Slide off drive sprocket spacer (Figure 40, item 1).

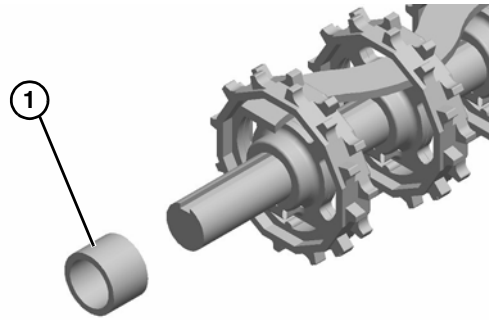

Figure 40

9. Slide entire sprocket assembly slightly outward, and remove the first sprocket (Figure 41, item 1) off the drive spindle and alignment bar (Figure 41, item 2).

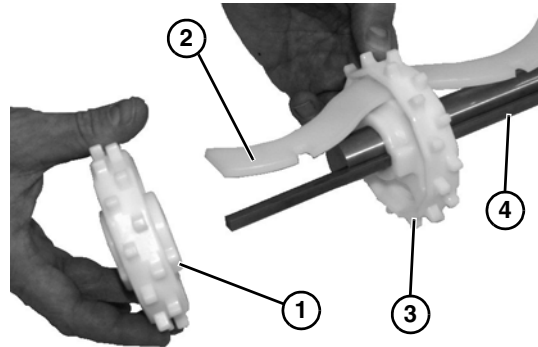

Figure 41

10. Remove remaining sprockets (Figure 41, item 3) off the alignment bar as you slide entire assembly off the drive spindle (Figure 41, item 4).

NOTE

To reassemble please note the placement of the sprockets on the alignment key.

Preventive Maintenance and Adjustment

Idler Puck and Spindle Replacement

| |
|--|
| ⚠ WARNING |
|  |
| SEVERE HAZARD! Exposed moving parts can cause severe injury. LOCK OUT POWER before removing guards or performing maintenance. |
| NOTE |
| <i>Idler tails are equipped with plain bushing pucks, replace when worn.</i> |

1. Open conveyor belt. See “Conveyor Belt Replacement” on page 14.
2. Remove four head plate bolts (Figure 42, item 1). Repeat on opposite side.

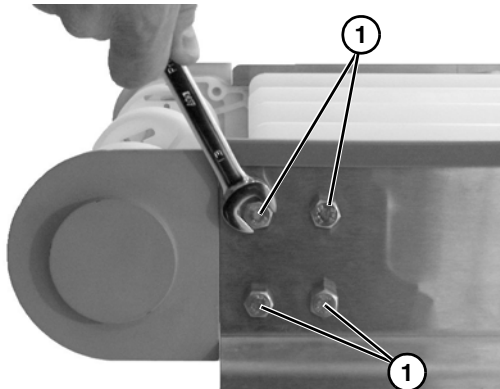

Figure 42

3. Remove idler tail assembly (Figure 43, item 1).

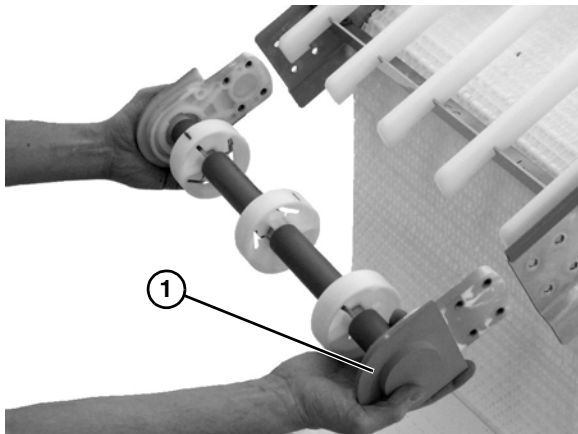

Figure 43

4. Slide off idler head plate (Figure 44, item 1) from shaft (Figure 44, item 2).

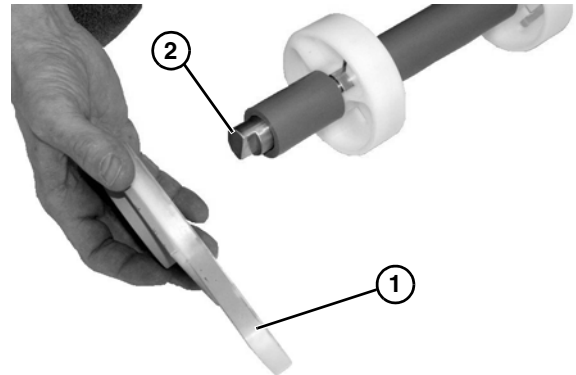

Figure 44

5. Slide off the round puck spacer (Figure 45, item 1).

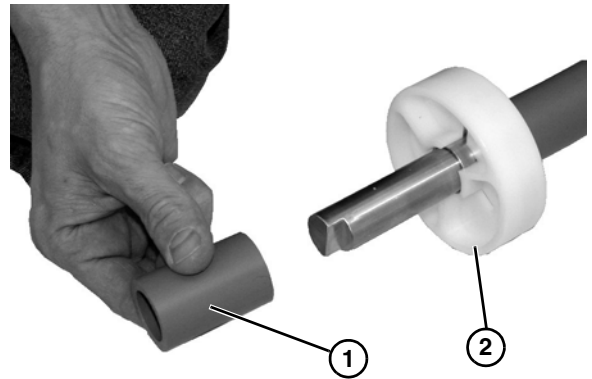



Figure 45

6. Slide off puck and replace (Figure 45, item 2).
7. Repeat as needed.

Preventive Maintenance and Adjustment

Nose Bar Idler Spindle Replacement

| |
|---|
|  WARNING |
|  |
| SEVERE HAZARD! Exposed moving parts can cause severe injury. LOCK OUT POWER before removing guards or performing maintenance. |

1. Open conveyor belt. See “Conveyor Belt Replacement” on page 14.
2. Remove the nose bar idler bar with wear strips and idler shoe attached (**Figure 46, item 1**).

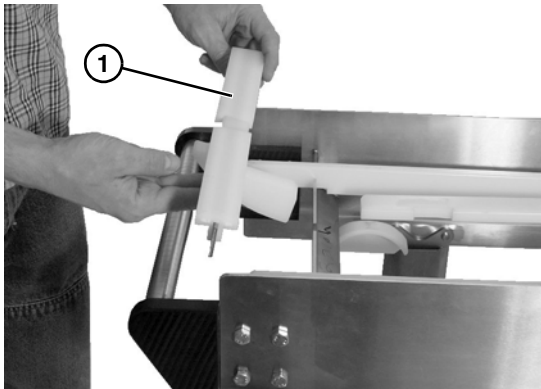

Figure 46

3. Remove and replace wear strips if worn (**Figure 47, item 1**).

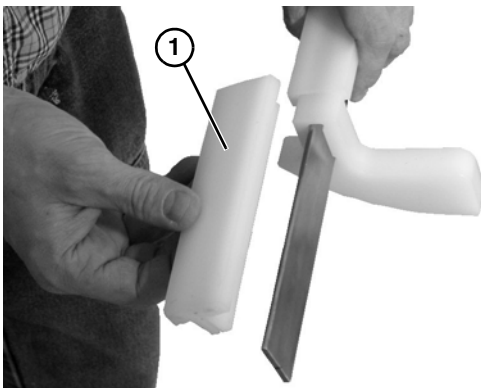

Figure 47

4. Remove and replace nose bar idler shoe if worn (**Figure 48, item 1**).

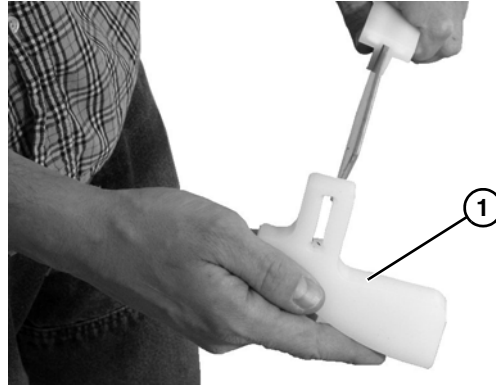

Figure 48

5. Remove four head plate bolts (**Figure 49, item 1**).



Figure 49

6. Slide off idler roller bearing assembly (**Figure 50, item 1**).

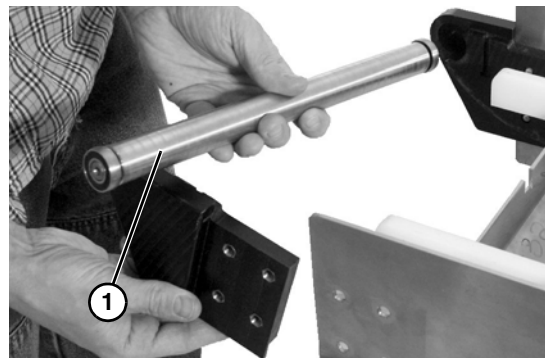



Figure 50

Preventive Maintenance and Adjustment

Bearing Replacement

| |
|---|
|  WARNING |
|  |
| Exposed moving parts can cause severe injury. LOCK OUT POWER before removing guards or performing maintenance. |

Drive Bearing Removal and Replacement

| |
|--|
|  WARNING |
|  |
| Drive shaft keyway may be sharp. HANDLE WITH CARE. |

1. See “Drive Sprocket and Spindle Replacement” on page 15. Follow steps 1 through 7.
2. Twist the bearing out (**Figure 51, item 1**).

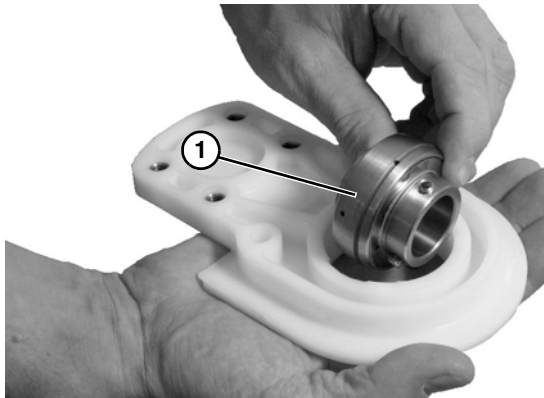

Figure 51

3. Replace bearing.

Idler Bearing Removal and Replacement

1. See “Nose Bar Idler Spindle Replacement” on page 18. Follow steps 1 through 6.
2. Using a bearing removal tool (**Figure 52, item 1**) remove the bearing (**Figure 52, item 2**).

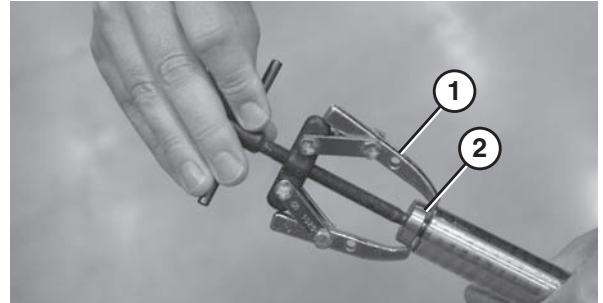

Figure 52

3. Press on new bearing.

| |
|--|
| CAUTION |
| Press on inner race only, pressing on outer race could damage bearing. |

Maintenance of Knuckles

Lower Knuckle

1. Remove belt. See “Conveyor Belt Replacement” on page 14.
2. Remove two cap screws (**Figure 53, item 1**) on each side of the knuckle and remove the hold down roller guards (**Figure 53, item 2**). Repeat on opposite side of the conveyor.

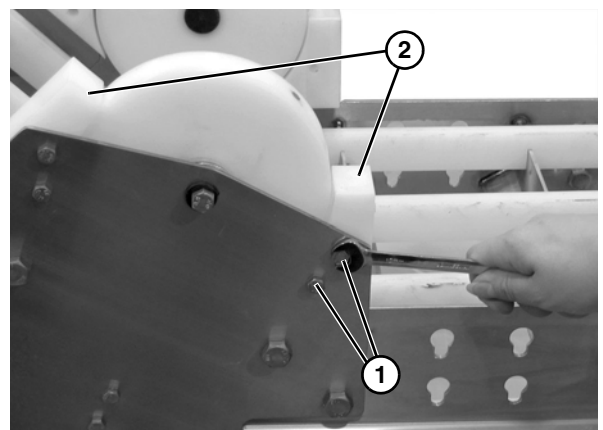

Figure 53

Preventive Maintenance and Adjustment

3. Remove the cap screw (**Figure 54, item 1**) and the hold down roller (**Figure 54, item 2**). Repeat on opposite side of the conveyor.

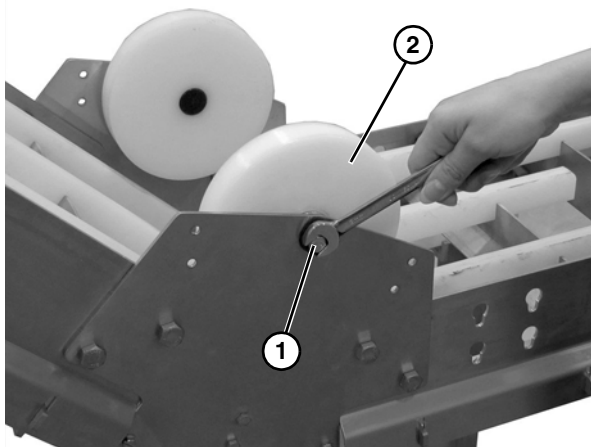

Figure 54

4. Remove two cap screws (**Figure 55, item 1**) and the inner belt return guide (**Figure 56, item 1**). Repeat on opposite side of the conveyor.

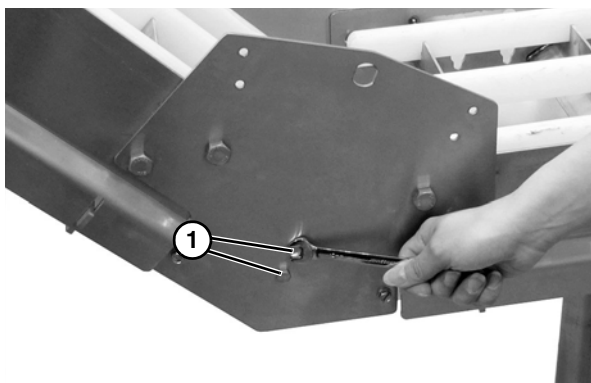

Figure 55

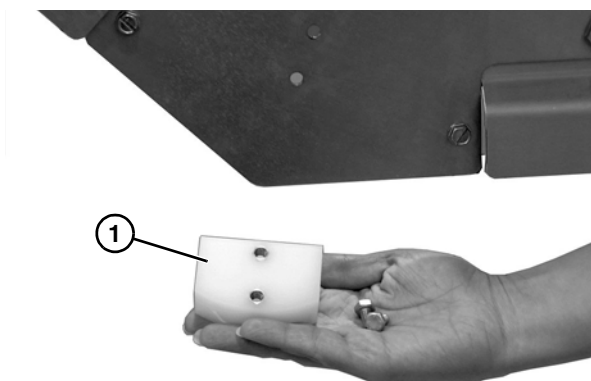

Figure 56

5. Replace parts as necessary.
6. Install parts reverse of removal.

Upper Knuckle

1. Remove belt. See “Conveyor Belt Replacement” on page 14.
2. Remove cap screw (**Figure 57, item 1**) and edge guide plate (**Figure 57, item 2**) from each side of the conveyor.

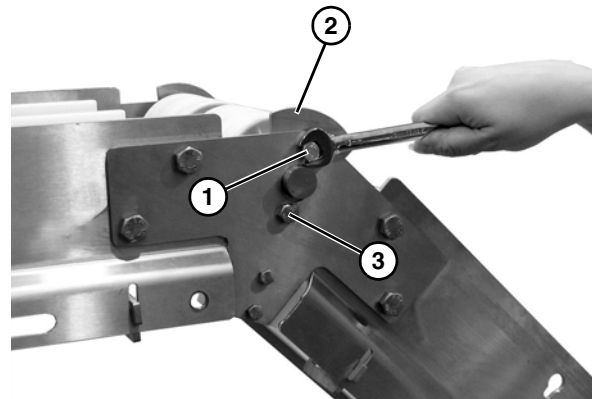

Figure 57

3. Remove the cap screw (**Figure 57, item 3**) and shaft clamp (**Figure 58, item 1**) from each side of the conveyor.

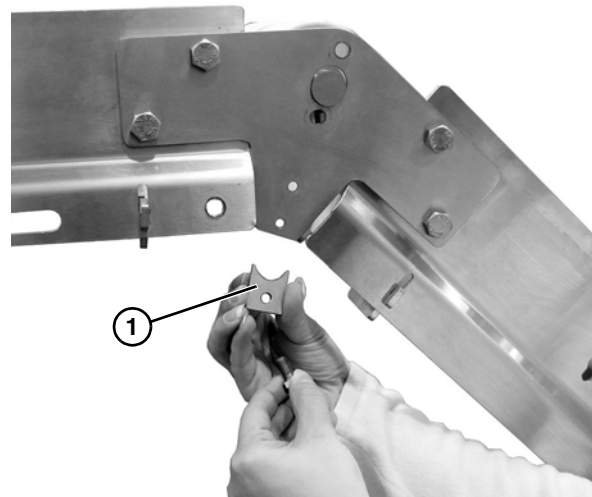

Figure 58

Preventive Maintenance and Adjustment

- Slide shaft (**Figure 59, item 1**) inwards to remove from knuckle frame (**Figure 60, item 1**).

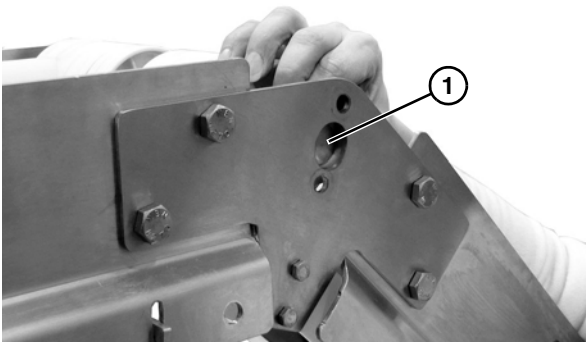

Figure 59

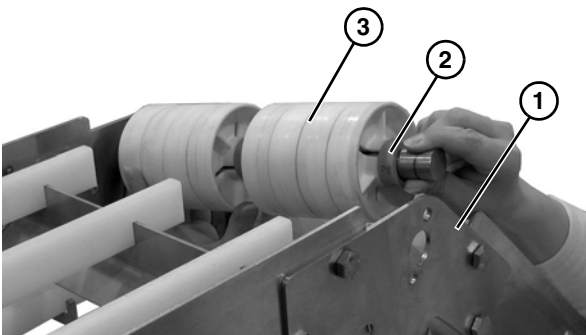

Figure 60

NOTE

Spacer (**Figure 60, item 2**) and pucks (**Figure 60, item 3**) are loose and can slide off the shaft.

- Remove spacer (**Figure 61, item 1**), rollers (**Figure 61, item 2**) and tube spacers (**Figure 61, item 3**) from shaft.

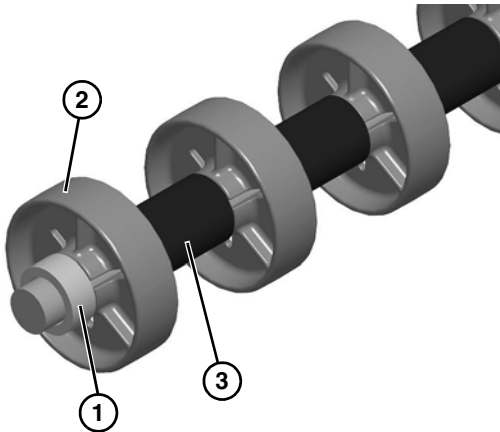

Figure 61

- Remove two cap screws (**Figure 62, item 1**) and inner belt return guide (**Figure 63, item 1**). Repeat on opposite side of the conveyor.

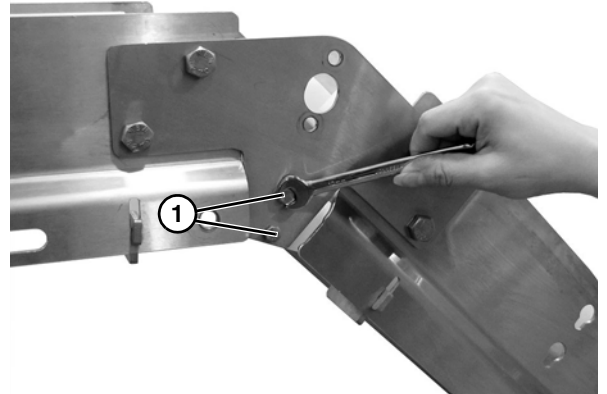

Figure 62

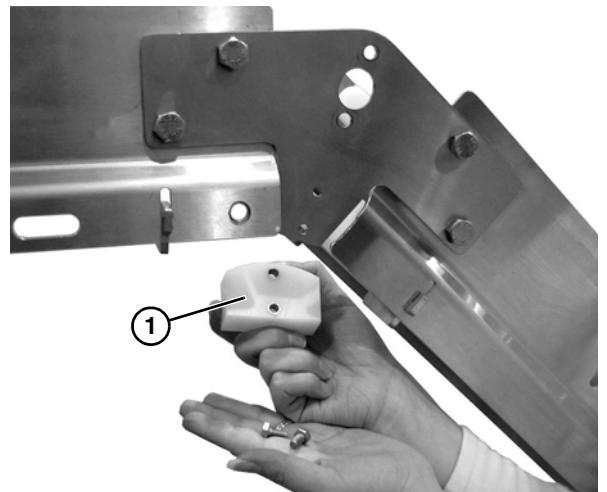



Figure 63

- Replace parts as necessary.
- Install parts reverse of removal.

Service Parts

NOTE

For replacement parts other than those shown in this section, contact an authorized Dorner Service Center or the factory. Key Service Parts and Kits are identified by the Performance Parts Kits logo . Dorner recommends keeping these parts on hand.

Drive End Components

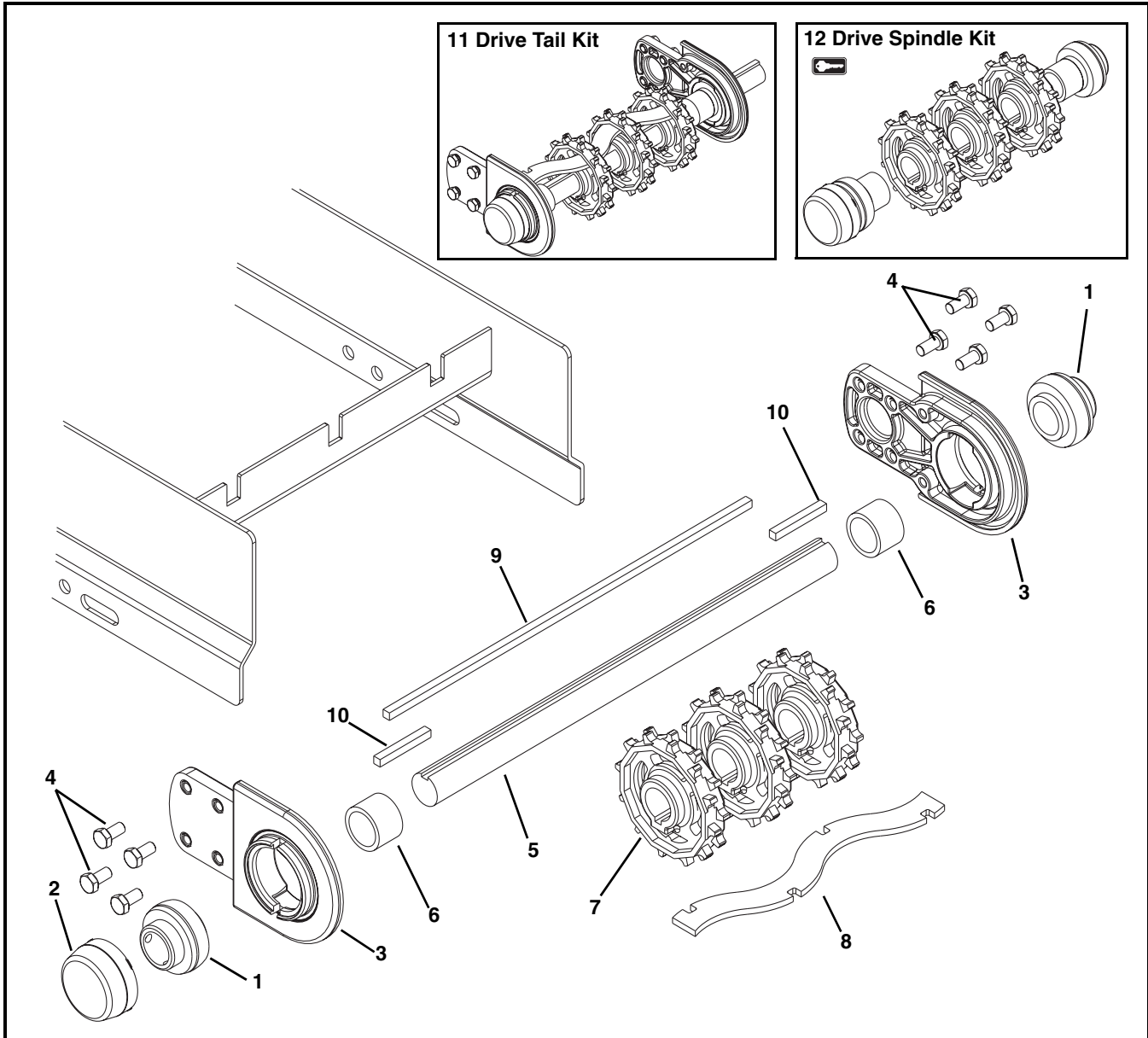

Service Parts

| Item | Part Number | Description |
|------|-------------------------|--|
| 1 | 735BK | Bearing Kit (Qty. 2) |
| 2* | 807-1454 | Bearing Cap |
| 3 | 532011 | Headplate |
| 4 | 960816MSS | Hex Head Cap Screw, M8-1.25 x 16 mm |
| 5 | See Drive Spindle Chart | Spindle |
| 6 | 532251-LLLLL | Sprocket Spacer |
| 7 | 807-1754 | Sprocket |
| 8 | 532124-WWW | Sprocket Alignment Bar |
| 9 | 532121-LLLLL | Square Key |
| 10 | 912-110SS | Square Key |

| Item | Part Number | Description |
|------|--------------|--|
| 11 | 735BDT-WWW | Drive Tail Kit for Bottom Mount (Includes items 1 through 10) |
| | 735SDT-WWW | Drive Tail Kit for Side Mount (Includes items 1 through 10) |
| | 735DBDT-WWW | Drive Tail Kit for Bottom Mount with Double Output Shafts (Includes items 1 through 10) |
| | 735DSDT-WWW | Drive Tail Kit for Side Mount with Double Output Shafts (Includes items 1 through 10) |
| | 735USDt-WWW | CE Drive Tail Kit for Side Mount (Includes items 1 through 10) |
| | 735UDSDT-WWW | CE Drive Tail Kit for Side Mount with Double Output Shafts (Includes items 1 through 10) |
| 12 | 735DS-WWW | Drive Spindle Kit (Includes items 1, 2, 6, and 7) |

 WWW = Conveyor width reference: 04 – 36 in 02 increments
 LLLLL = Part length in inches with 2 decimal places.
 Example: Part Length = 95.25" LLLLL = 09525
 * Not available with double output shafts

| Drive Spindle Chart - US Gearmotor Version | | | | |
|--|--------------|--------------|---------------------------------------|-------------------------------------|
| Conveyor Width | Bottom Mount | Side Mount | Bottom Mount with Double Output Shaft | Side Mount with Double Output Shaft |
| 4" | 532113-00743 | 532232-01344 | 532113-00899 | 532232-01500 |
| 6" | 532113-00943 | 532232-01544 | 532113-01099 | 532232-01700 |
| 8" | 532113-01143 | 532232-01744 | 532113-01299 | 532232-01900 |
| 10" | 532113-01341 | 532232-01942 | 532113-01497 | 532232-02098 |
| 12" | 532113-01538 | 532232-02139 | 532113-01694 | 532232-02295 |
| 14" | 532113-01736 | 532232-02337 | 532113-01892 | 532232-02493 |
| 16" | 532113-01933 | 532232-02534 | 532113-02089 | 532232-02690 |
| 18" | 532113-02131 | 532232-02732 | 532113-02287 | 532232-02888 |
| 20" | 532113-02328 | 532232-02929 | 532113-02484 | 532232-03085 |
| 22" | 532113-02526 | 532232-03127 | 532113-02682 | 532232-03283 |
| 24" | 532113-02723 | 532232-03324 | 532113-02879 | 532232-03480 |
| 26" | 532113-02921 | 532232-03522 | 532113-03077 | 532232-03678 |
| 28" | 532113-03118 | 532232-03719 | 532232-03719 | 532232-03875 |
| 30" | 532113-03316 | 532232-03917 | 532113-03472 | 532232-04073 |
| 32" | 532113-03513 | 532232-04114 | 532113-03669 | 532232-04270 |
| 34" | 532113-03711 | 532232-04312 | 532113-03867 | 532232-04468 |
| 36" | 532113-03908 | 532232-04509 | 532113-04064 | 532232-04665 |

| Drive Spindle Chart - CE Gearmotor Version | | | | |
|--|--------------|--------------|---------------------------------------|-------------------------------------|
| Conveyor Width | Bottom Mount | Side Mount | Bottom Mount with Double Output Shaft | Side Mount with Double Output Shaft |
| 4" | 532113-00743 | 532291-01147 | 532113-00899 | 532291-01303 |
| 6" | 532113-00943 | 532291-01347 | 532113-01099 | 532291-01503 |
| 8" | 532113-01143 | 532291-01547 | 532113-01299 | 532291-01703 |
| 10" | 532113-01341 | 532291-01745 | 532113-01497 | 532291-01901 |
| 12" | 532113-01538 | 532291-01942 | 532113-01694 | 532291-02098 |
| 14" | 532113-01736 | 532291-02140 | 532113-01892 | 532291-02296 |
| 16" | 532113-01933 | 532291-02337 | 532113-02089 | 532291-02493 |
| 18" | 532113-02131 | 532291-02535 | 532113-02287 | 532291-02691 |
| 20" | 532113-02328 | 532291-02732 | 532113-02484 | 532291-02888 |
| 22" | 532113-02526 | 532291-02930 | 532113-02682 | 532291-03086 |
| 24" | 532113-02723 | 532291-03127 | 532113-02879 | 532291-03283 |
| 26" | 532113-02921 | 532291-03325 | 532113-03077 | 532291-03481 |
| 28" | 532113-03118 | 532291-03522 | 532113-03274 | 532291-03678 |
| 30" | 532113-03316 | 532291-03720 | 532113-03472 | 532291-03876 |
| 32" | 532113-03513 | 532291-03917 | 532113-03669 | 532291-04073 |
| 34" | 532113-03711 | 532291-04115 | 532113-03867 | 532291-04271 |
| 36" | 532113-03908 | 532291-04312 | 532113-04064 | 532291-04468 |

Service Parts

Idler End Components

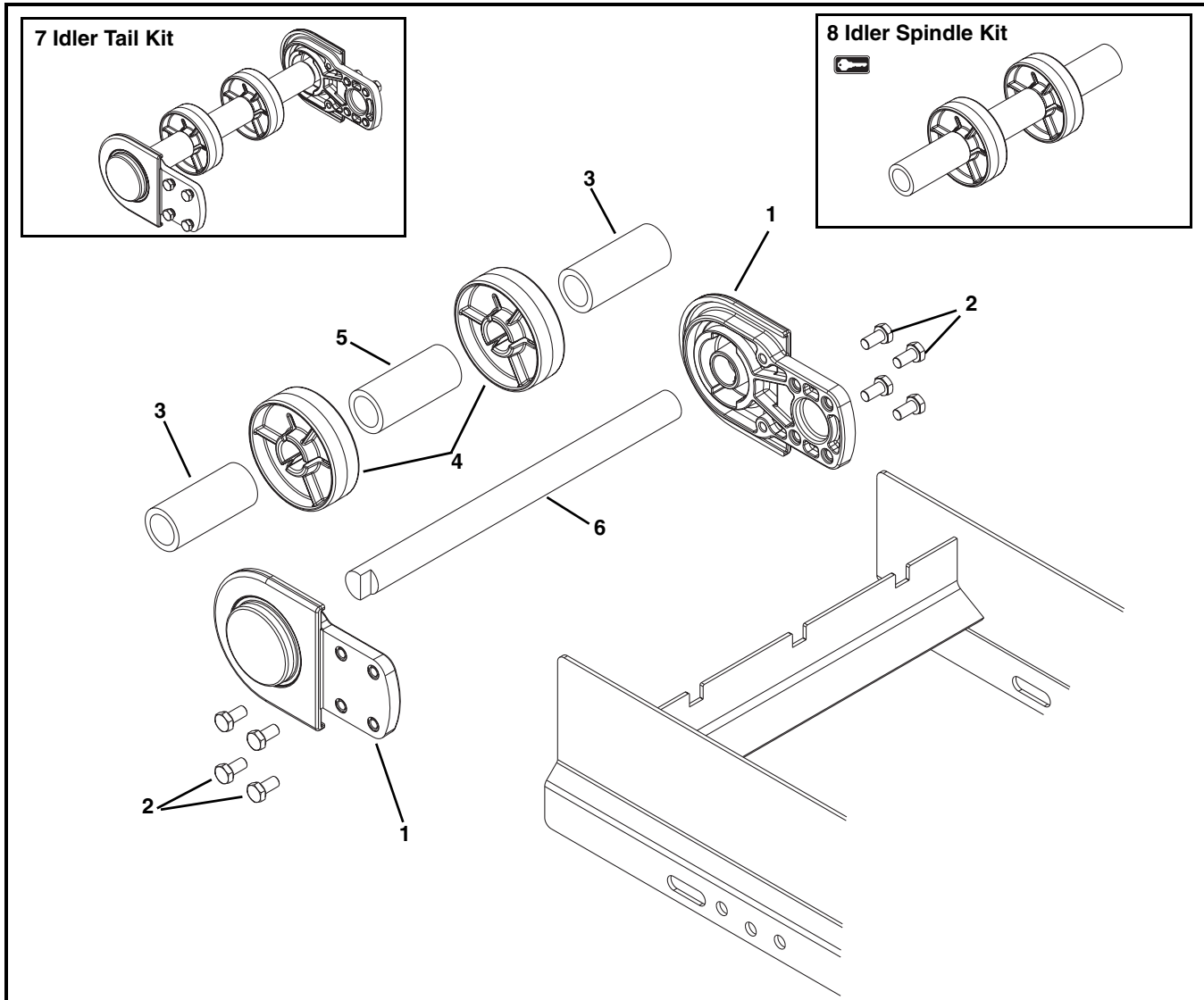

| Item | Part Number | Description |
|--|-------------------------|--|
| 1 | 532012 | Headplate Assembly |
| 2 | 960816M | Hex Head Cap Screw, M8-1.25 x 16 mm |
| 3 | 532128- <u>WW</u> | End Tube Spacer |
| 4 | 506296 | Idler Puck |
| 5 | 532127- <u>LLLLL</u> | Tube Spacer |
| 6 | See Idler Spindle Chart | Spindle |
| 7 | 735IT- <u>WW</u> | Idler Tail Kit (Includes items 1 through 6) |
| 8 | 735IS- <u>WW</u> | Idler Spindle Kit (Includes items 3, 4, and 5) |
| <u>WW</u> = Conveyor width reference: 04 – 36 in 02 increments | | |
| <u>LLLLL</u> = Part length in inches with 2 decimal places. | | |
| Example: Part Length = 95.25" <u>LLLLL</u> = 09525 | | |

| Idler Spindle Chart | |
|---------------------|--------------|
| Conveyor Width | Spindle |
| 4" | 532118-00412 |
| 6" | 532118-00612 |
| 8" | 532118-00812 |
| 10" | 532118-01010 |
| 12" | 532118-01207 |
| 14" | 532118-01405 |
| 16" | 532118-01602 |
| 18" | 532118-01800 |
| 20" | 532118-01997 |
| 22" | 532118-02195 |
| 24" | 532118-02392 |
| 26" | 532118-02590 |
| 28" | 532118-02787 |
| 30" | 532118-02985 |
| 32" | 532118-03182 |
| 34" | 532118-03380 |
| 36" | 532118-03577 |

Nose Bar Idler End Components

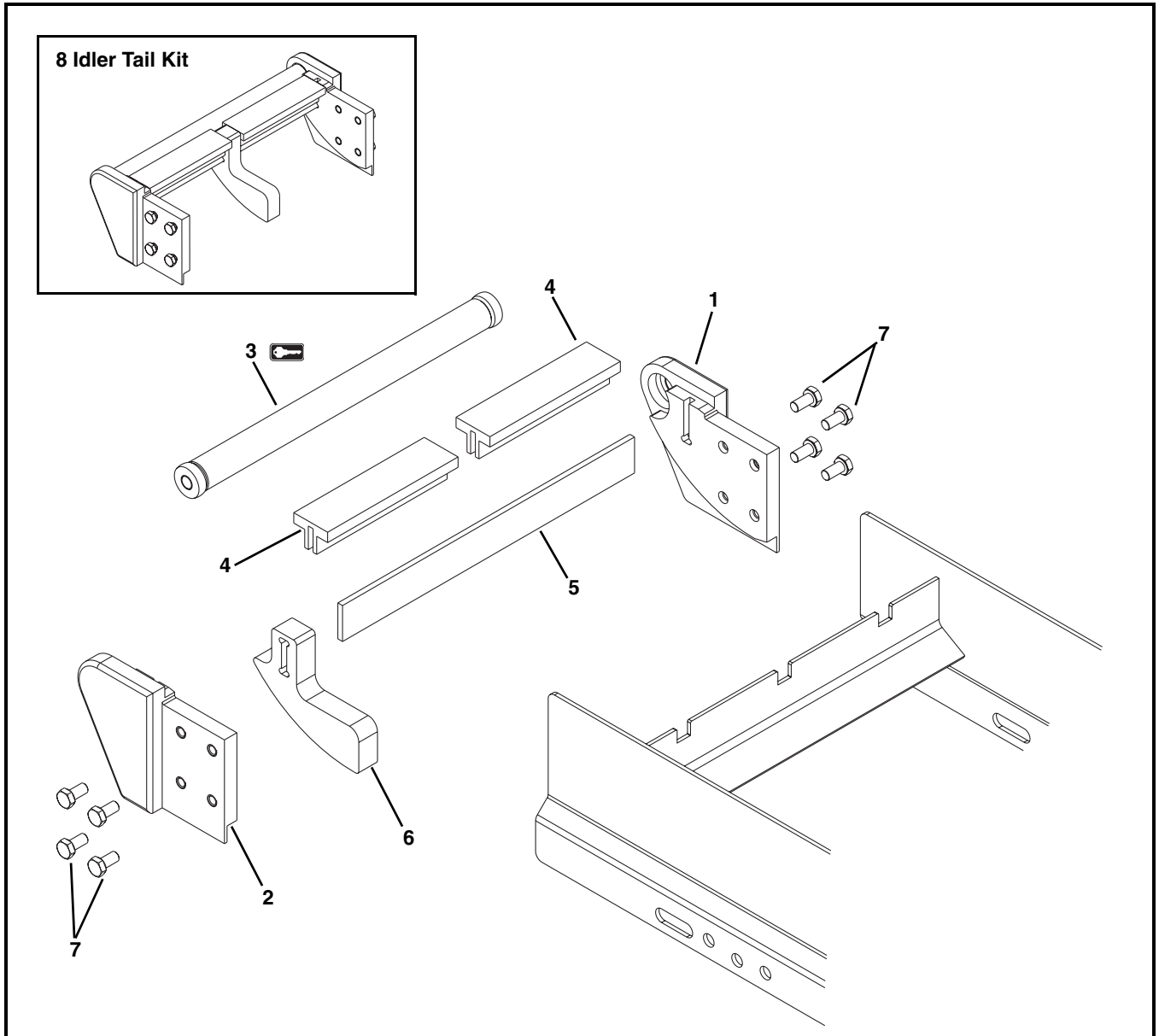



| Item | Part Number | Description |
|------|-------------------|------------------------------|
| 1 | 532025 | Nosebar Headplate Right Hand |
| 2 | 532026 | Nosebar Headplate Left Hand |
| 3 | 735NBK- <u>WW</u> | Bearing Kit |
| 4 | 532137- <u>WW</u> | Wear Strip |
| 5 | 532135- <u>WW</u> | Nosebar Idler Bar |

| Item | Part Number | Description |
|--|-------------------|---|
| 6 | 532139 | Nosebar Idler Shoe |
| 7 | 960816M | Hex Head Cap Screw, M8-1.25 x 16 mm |
| 8 | 735NBT- <u>WW</u> | Nose Bar Idler Tail Kit (Includes items 1 through 7) |
| <u>WW</u> = Conveyor width reference: 04 – 36 in 02 increments | | |

Service Parts

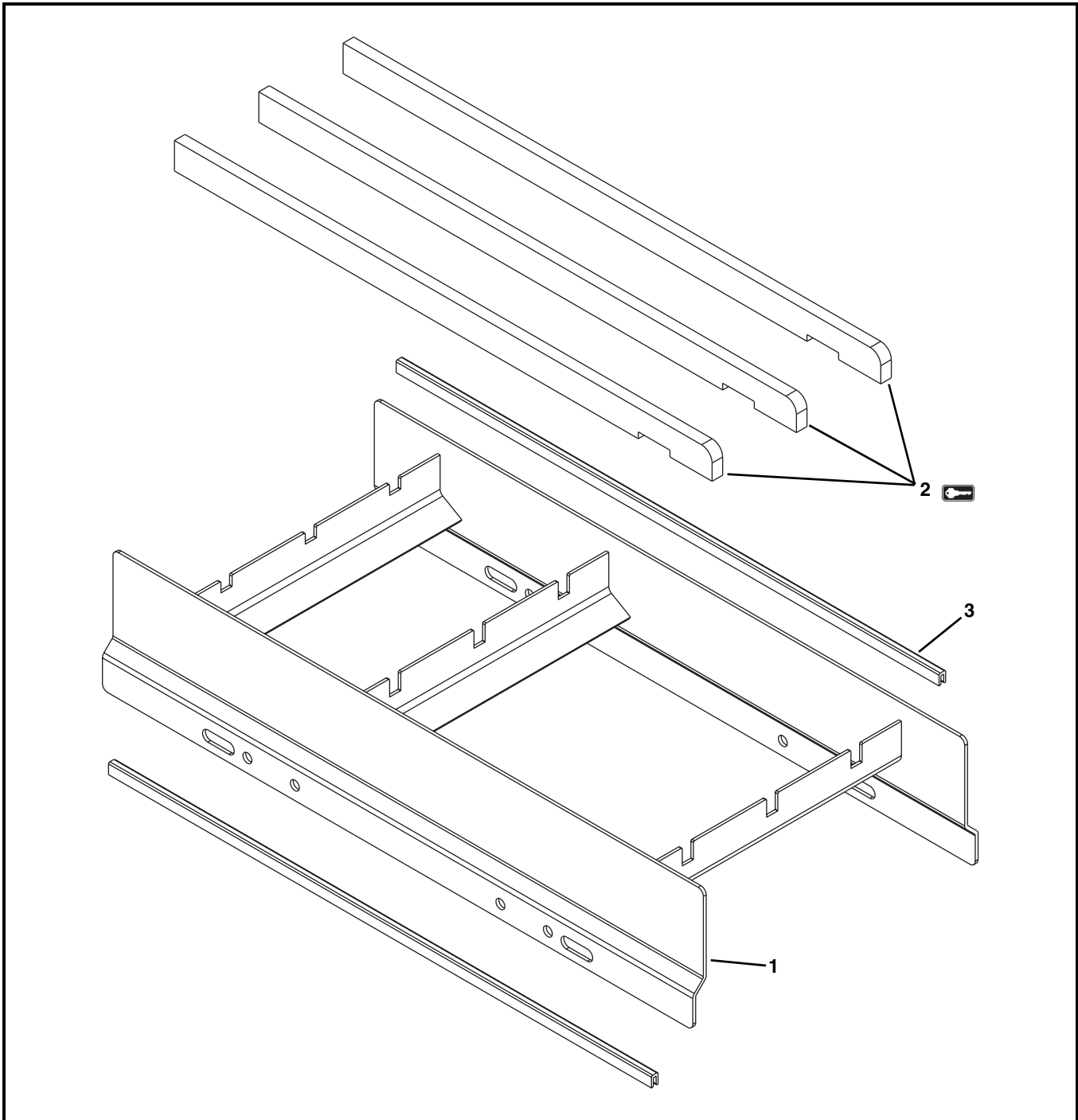
Frame Assembly



| Item | Part Number | Description |
|---|----------------------|---------------------------------------|
| 1 | ----- | Consult Factory for Frame Part Number |
| 2 | 532223- <u>LLLLL</u> | Wear Strip |
|  | | |
| 3 | 532225- <u>LLLLL</u> | Bar Cap |
| <u>LLLLL</u> = Length in inches with 2 decimal places. | | |
| Length Example: Length = 95.25" <u>LLLLL</u> = 09525 | | |

Upper Knuckle

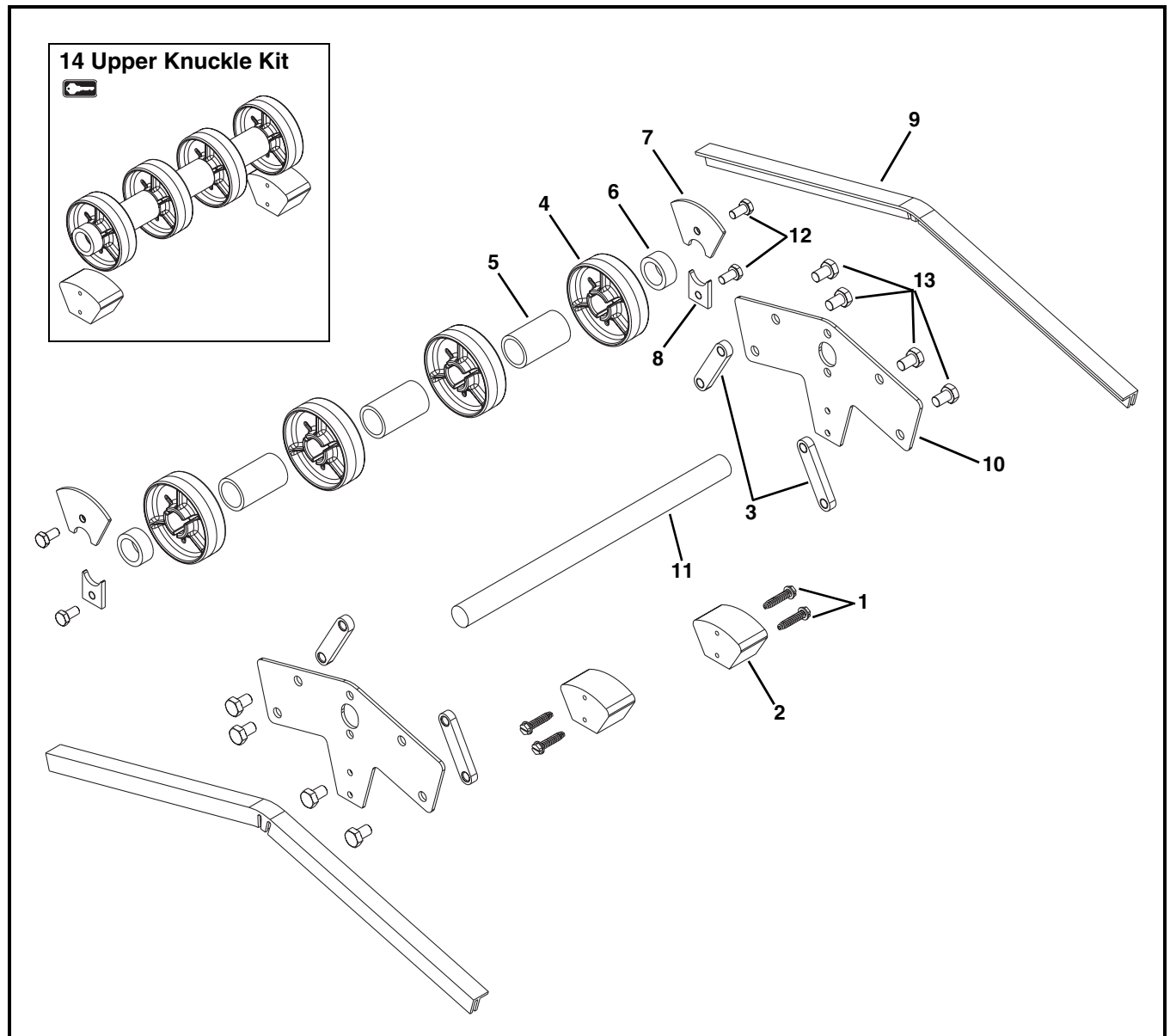

| Item | Part Number | Description |
|------|--------------|--------------------------------|
| 1 | 807-1884 | Sheet Metal Screw, #14 x 1.25 |
| 2 | 352326 | Inner Belt Return Guide |
| 3 | 500199 | Connector |
| 4 | 506296 | Idler Puck |
| 5 | 532251-00228 | Tube Spacer |
| 6 | 532305 | Spacer |
| 7 | 532353 | Edge Guide Plate |
| 8 | 532358 | Shaft Clamp |
| 9 | 532361 | Bar Cap for Straight Conveyors |
| | 532360 | Bar Cap for Curve Conveyors |
| 10 | 532376-AA | Side Plate |

| Item | Part Number | Description |
|------|-------------|--|
| 11 | 532377-WW | Shaft |
| 12 | 960816MSS | Hex Head Cap Screw, M8-1.25 x 16 mm |
| 13 | 961016MSS | Hex Head Cap Screw, M10-1.50 x 16 mm |
| 14 | 735UNS-WW | Upper Knuckle Kit for Straight Conveyor (Includes Items 2, 4, 5 and 6) |
| | 735UNC-WW | Upper Knuckle Kit for Curve Conveyor (Includes Items 2, 4, 5 and 6) |
| | | AA = Angle 05, 10, 15, 30, 45 or 60 |
| | | WW = Conveyor width reference: 08 – 24 in 02 increments |

Service Parts

Lower Knuckle

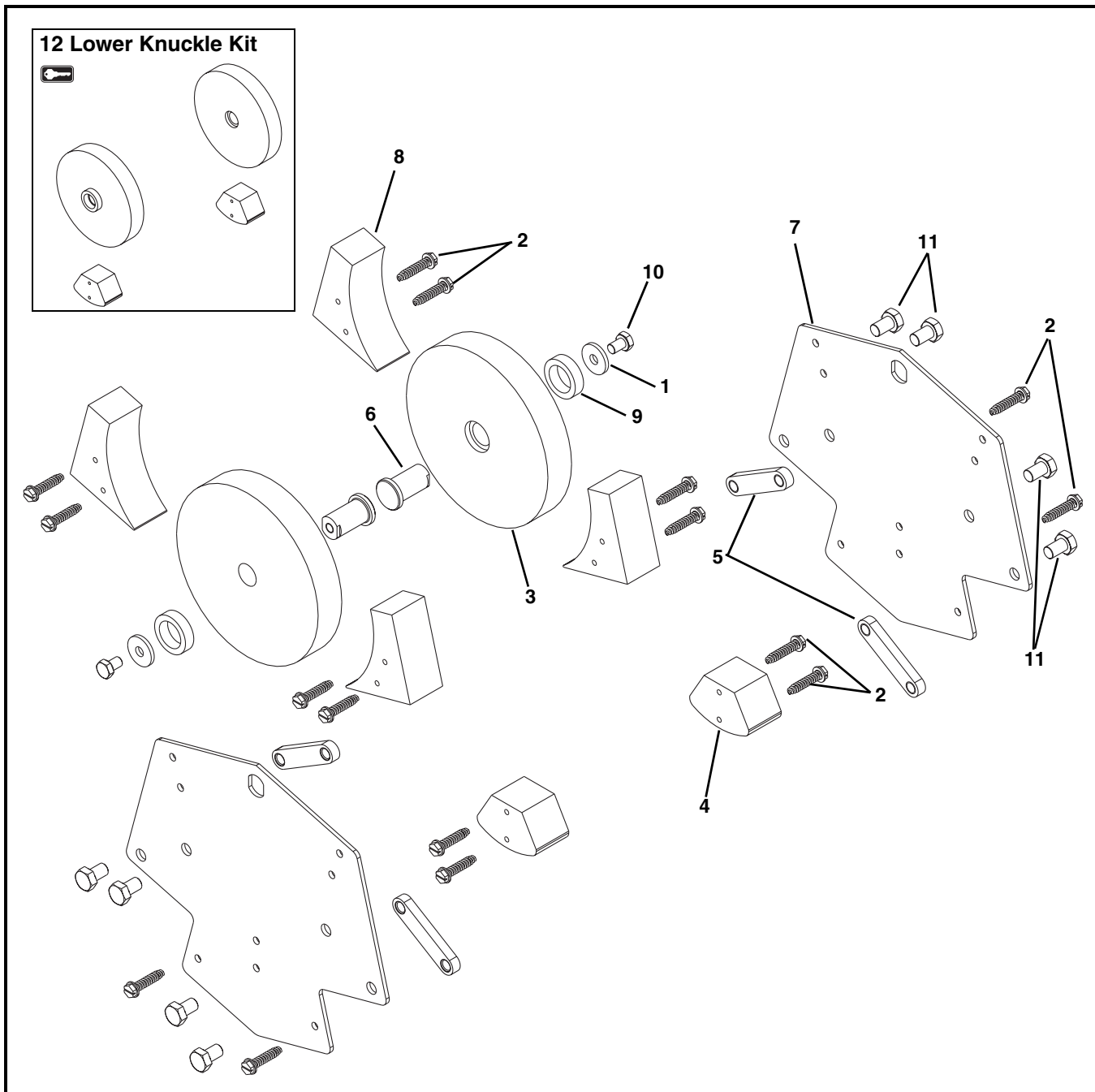

| Item | Part Number | Description |
|------|-------------|-------------------------------|
| 1 | 807-1838 | Washer |
| 2 | 807-1884 | Sheet Metal Screw, #14 x 1.25 |
| 3 | 352324 | Hold Down Guide |
| 4 | 352326 | Inner Belt Return Guide |
| 5 | 500199 | Connector |
| 6 | 532351 | Stub Shaft |
| 7 | 532355-AA | Side Plate |

| Item | Part Number | Description |
|------|-------------|--|
| 8 | 532359 | Hold Down Roller Guard |
| 9 | 532379 | Hold Down Roller Spacer |
| 10 | 960812MSS | Hex Head Cap Screw, M8-1.25 x 12 mm |
| 11 | 961012MSS | Hex Head Cap Screw, M10-1.50 x 12 mm |
| 12 | 735LN | Lower Knuckle Kit (Includes Items 3, 4 and 9) |

AA = Angle 05, 10, 15, 30, 45 or 60

Connecting Assembly

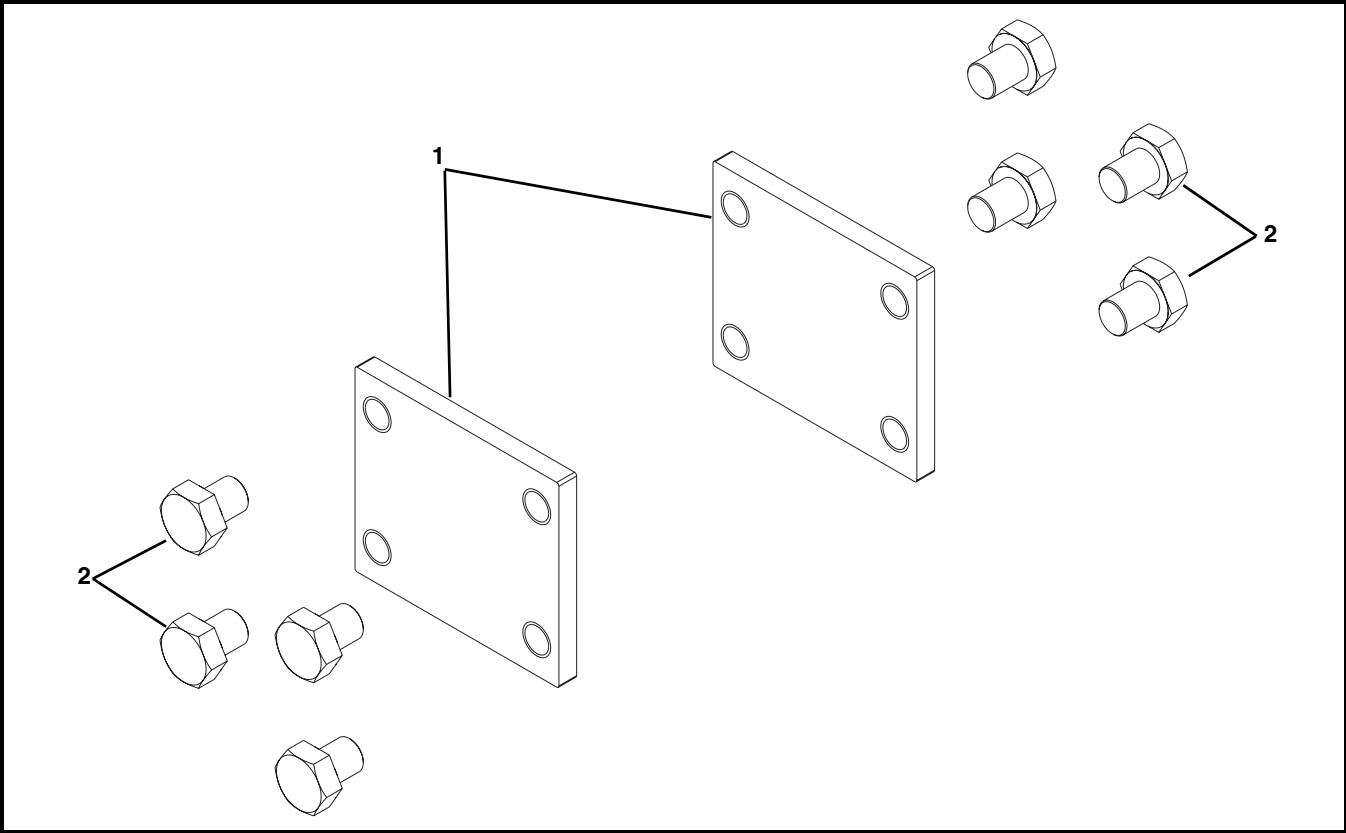

| Item | Part Number | Description |
|------|-------------|---|
| 1 | 532157 | Connector Plate |
| 2 | 961012MSS | Hex Head Cap Screw, M10-1.50 x 12 mm |

Service Parts

1" (25 mm) High Sides

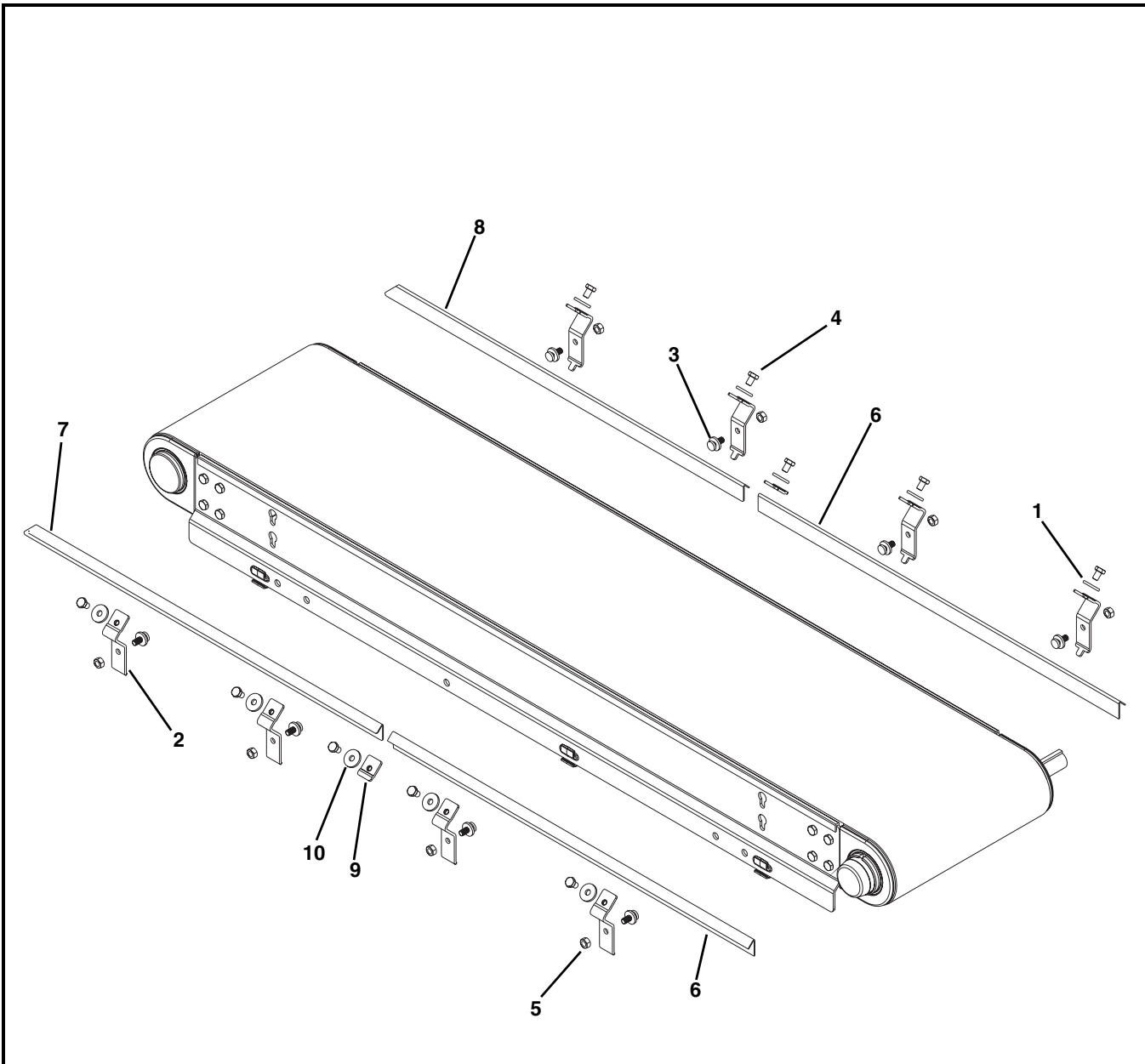

| Item | Part Number | Description |
|------|--------------|-------------------------------------|
| 1 | 807-1821 | Washer |
| 2 | 532183 | 1" Bracket |
| 3 | 532191 | Carriage Bolt, M8 x 20 mm |
| 4 | 960812M | Hex Head Cap Screw, M8-1.25 x 12 mm |
| 5 | 990801MSS | Hex Nut |
| 6 | 532175-LLLLL | Guiding Straight |

| Item | Part Number | Description |
|---|--------------|--------------------|
| 7 | 532176-LLLLL | Guiding Left Hand |
| 8 | 532177-LLLLL | Guiding Right Hand |
| 9 | 532196 | Connecting Clip |
| 10 | 807-1838 | Washer |
| LLLLL = Length in inches with 2 decimal places. | | |
| Length Example: Length = 95.25" LLLLL = 09525 | | |

3" (76 mm) High Sides

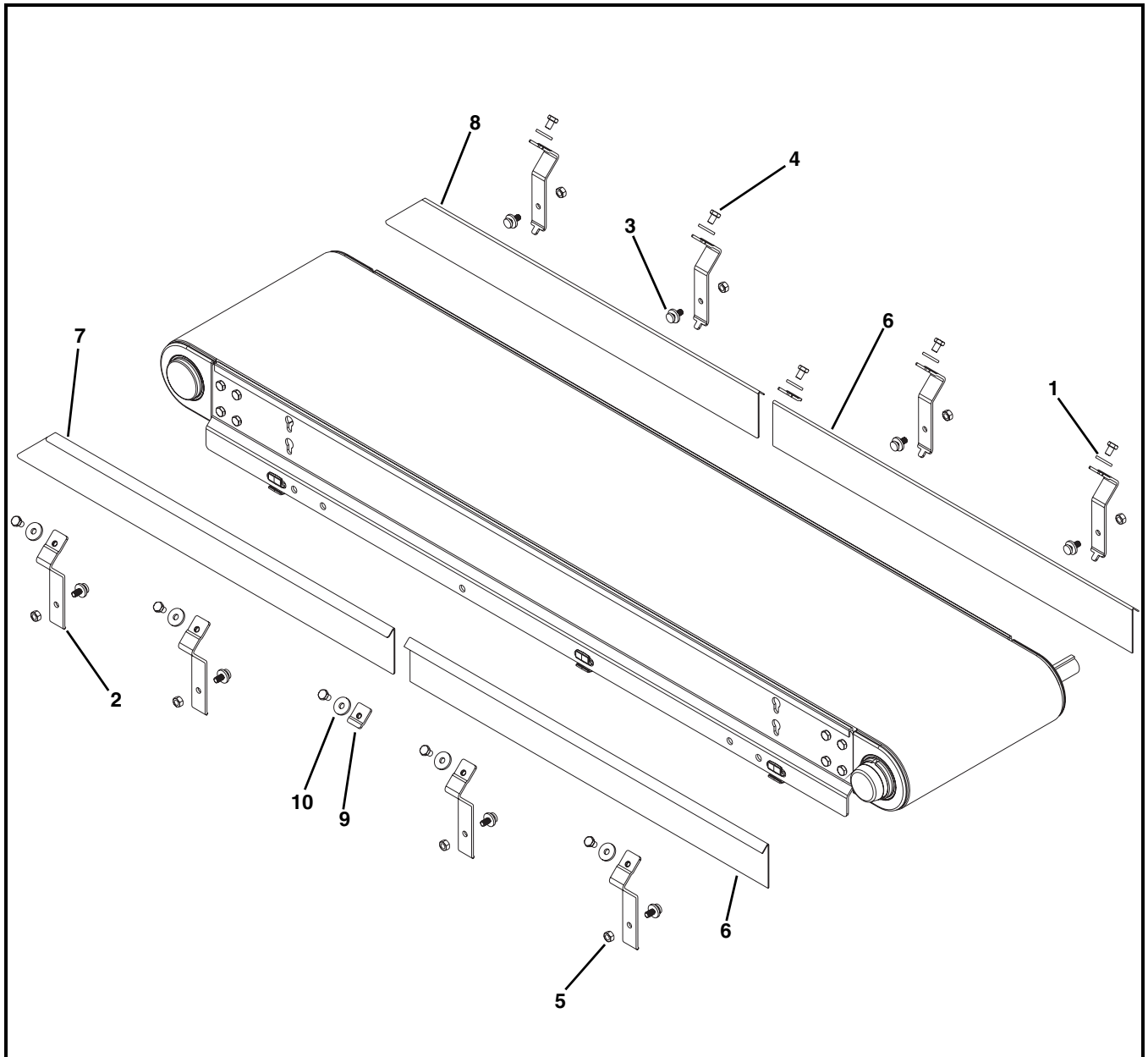

| Item | Part Number | Description |
|------|--------------|-------------------------------------|
| 1 | 807-1821 | Washer |
| 2 | 532185 | 3" Bracket |
| 3 | 532191 | Carriage Bolt, M8 x 20 mm |
| 4 | 960812M | Hex Head Cap Screw, M8-1.25 x 12 mm |
| 5 | 990801MSS | Hex Nut |
| 6 | 532172-LLLLL | Guiding Straight |

| Item | Part Number | Description |
|---|--------------|--------------------|
| 7 | 532173-LLLLL | Guiding Left Hand |
| 8 | 532174-LLLLL | Guiding Right Hand |
| 9 | 532196 | Connecting Clip |
| 10 | 807-1838 | Washer |
| LLLLL = Length in inches with 2 decimal places. | | |
| Length Example: Length = 95.25" LLLLL = 09525 | | |

Service Parts

Fully Adjustable Round Guides

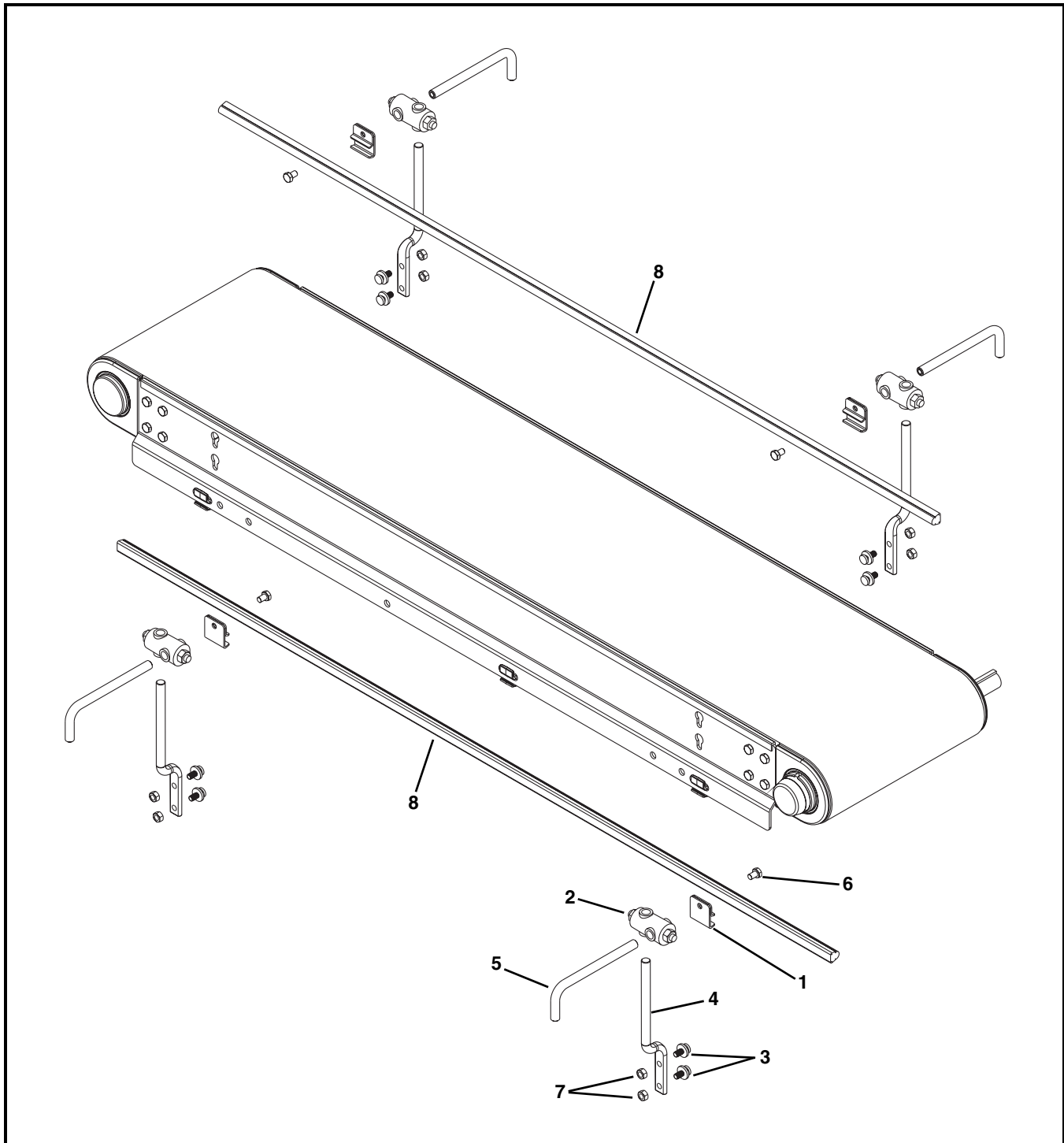

| Item | Part Number | Description |
|------|-------------|---------------------------|
| 1 | 807-015 | Rail Clamp |
| 2 | 807-1387 | Cross Block Clamp |
| 3 | 532191 | Carriage Bolt, M8 x 20 mm |
| 4 | 532192 | Offset Guide Post |
| 5 | 532300 | Post Guide |

| Item | Part Number | Description |
|---|--------------|-------------------------------------|
| 6 | 960812MSS | Hex Head Cap Screw, M8-1.25 x 12 mm |
| 7 | 990801MSS | Hex Nut |
| 8 | 532167-LLLLL | Round Guide Rail |
| LLLLL = Length in inches with 2 decimal places. | | |
| Length Example: Length = 95.25" LLLLL = 09525 | | |

Tool-Less Fully Adjustable Round Guides

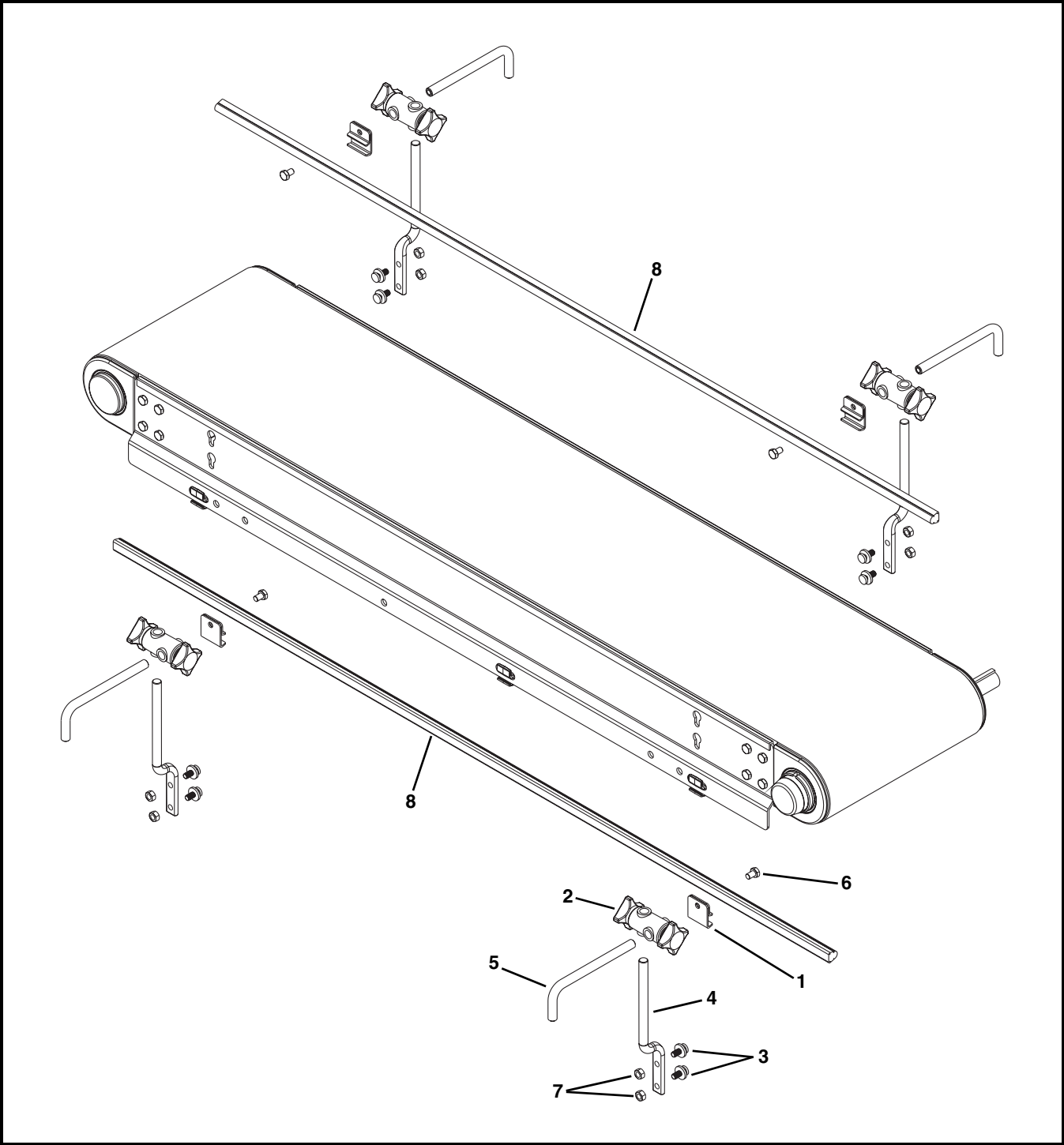

| Item | Part Number | Description |
|------|-------------|---------------------------|
| 1 | 807-015 | Rail Clamp |
| 2 | 807-1470 | Cross Block Clamp |
| 3 | 532191 | Carriage Bolt, M8 x 20 mm |
| 4 | 532192 | Offset Guide Post |
| 5 | 532300 | Post Guide |

| Item | Part Number | Description |
|---|--------------|-------------------------------------|
| 6 | 960812MSS | Hex Head Cap Screw, M8-1.25 x 12 mm |
| 7 | 990801MSS | Hex Nut |
| 8 | 532167-LLLLL | Round Guide Rail |
| LLLLL = Length in inches with 2 decimal places. | | |
| Length Example: Length = 95.25" LLLLL = 09525 | | |

Service Parts

Twin Rail Adjustable Round Guides

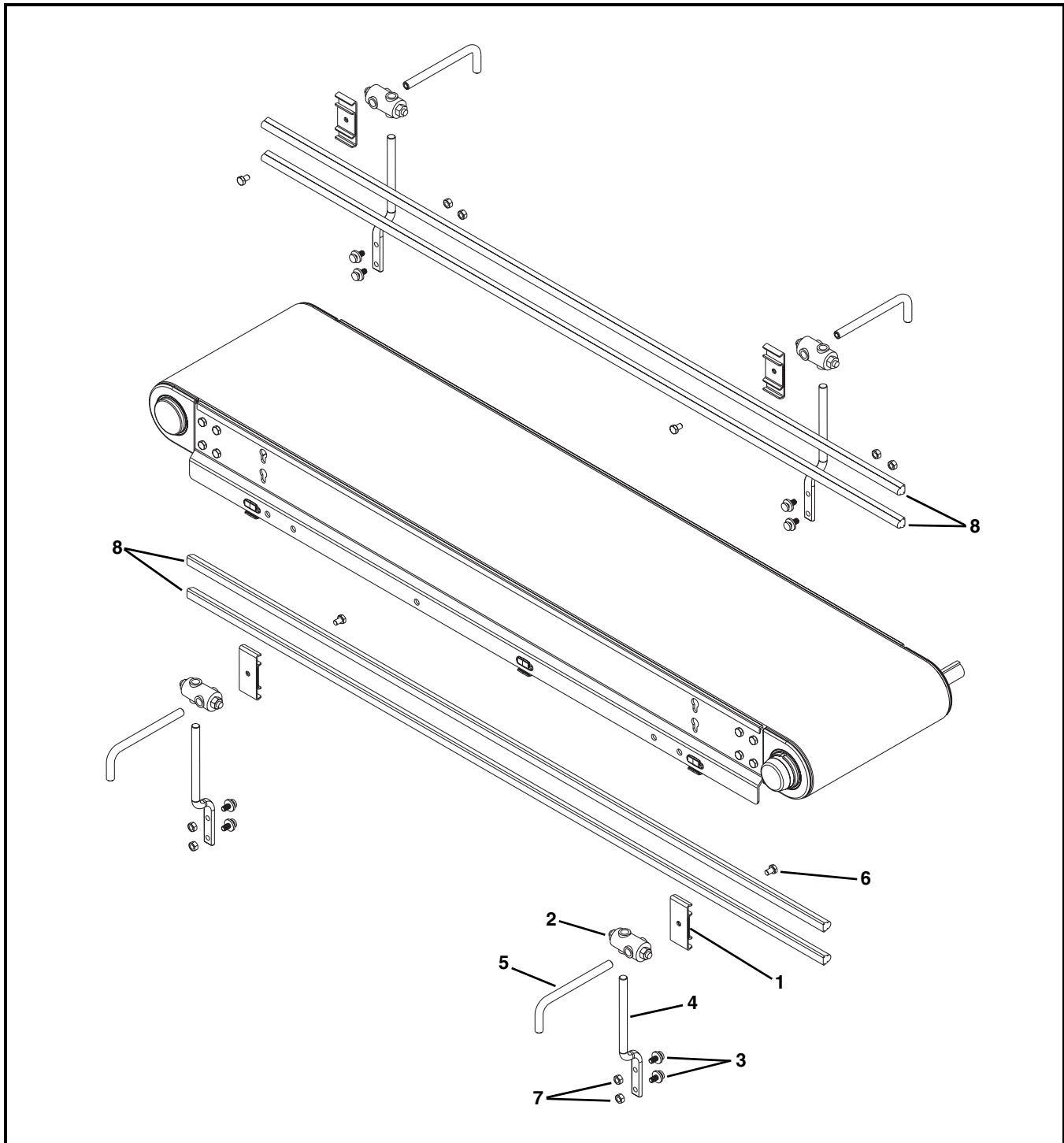

| Item | Part Number | Description |
|------|-------------|---------------------------|
| 1 | 901414 | Rail Clamp |
| 2 | 807-1387 | Cross Block Clamp |
| 3 | 532191 | Carriage Bolt, M8 x 20 mm |
| 4 | 532192 | Offset Guide Post |
| 5 | 532300 | Post Guide |

| Item | Part Number | Description |
|---|--------------|-------------------------------------|
| 6 | 960812MSS | Hex Head Cap Screw, M8-1.25 x 12 mm |
| 7 | 990801MSS | Hex Nut |
| 8 | 532167-LLLLL | Round Guide Rail |
| LLLLL = Length in inches with 2 decimal places. | | |
| Length Example: Length = 95.25" LLLLL = 09525 | | |

Tool-Less Twin Rail Adjustable Round Guides

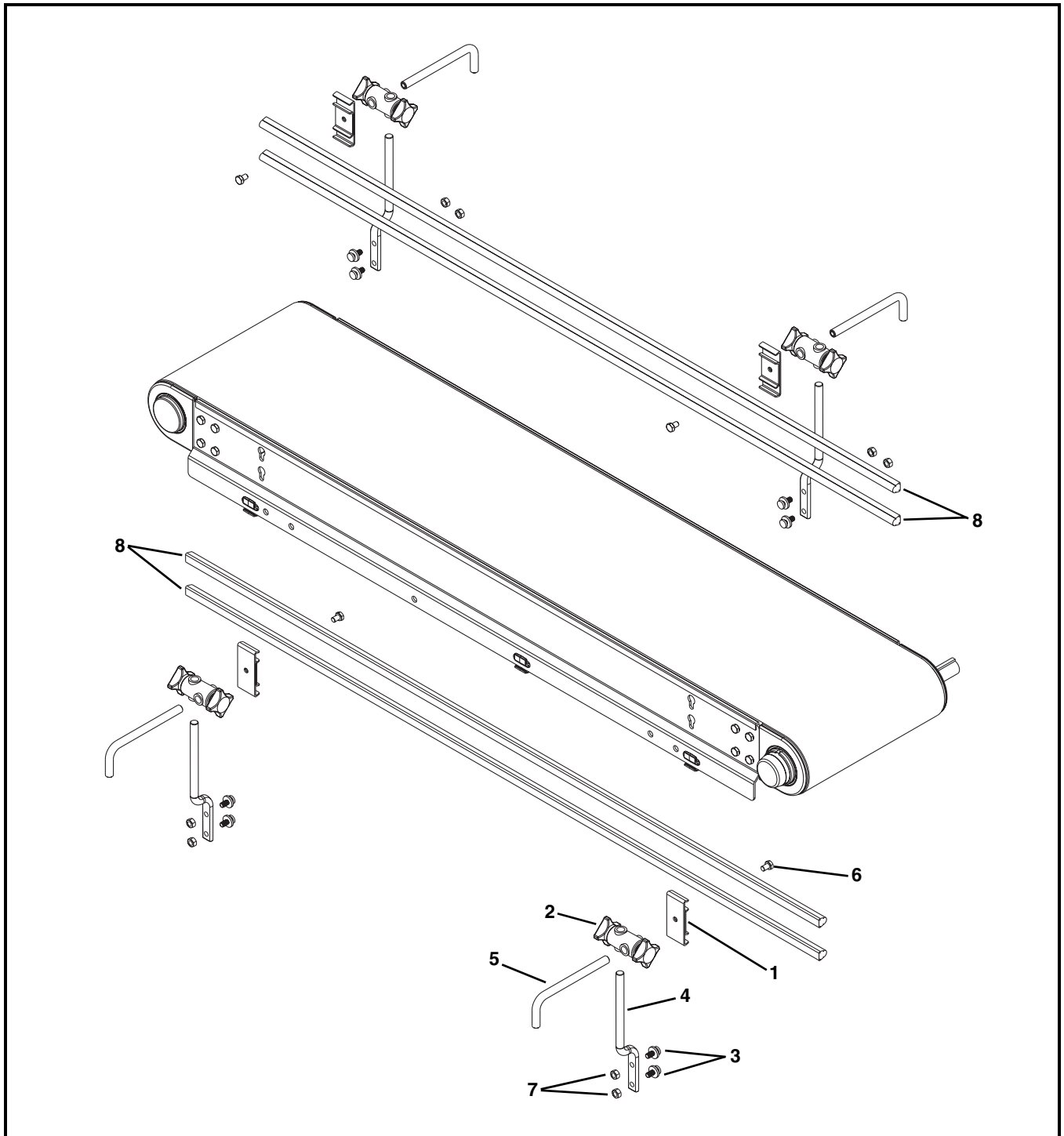

| Item | Part Number | Description |
|------|-------------|---------------------------|
| 1 | 901414 | Rail Clamp |
| 2 | 807-1470 | Cross Block Clamp |
| 3 | 532191 | Carriage Bolt, M8 x 20 mm |
| 4 | 532192 | Offset Guide Post |
| 5 | 532300 | Post Guide |

| Item | Part Number | Description |
|---|--------------|-------------------------------------|
| 6 | 960812MSS | Hex Head Cap Screw, M8-1.25 x 12 mm |
| 7 | 990801MSS | Hex Nut |
| 8 | 532167-LLLLL | Round Guide Rail |
| LLLLL = Length in inches with 2 decimal places. | | |
| Length Example: Length = 95.25" LLLLL = 09525 | | |

Service Parts

Fully Adjustable 1" (25 mm) Flat Guides

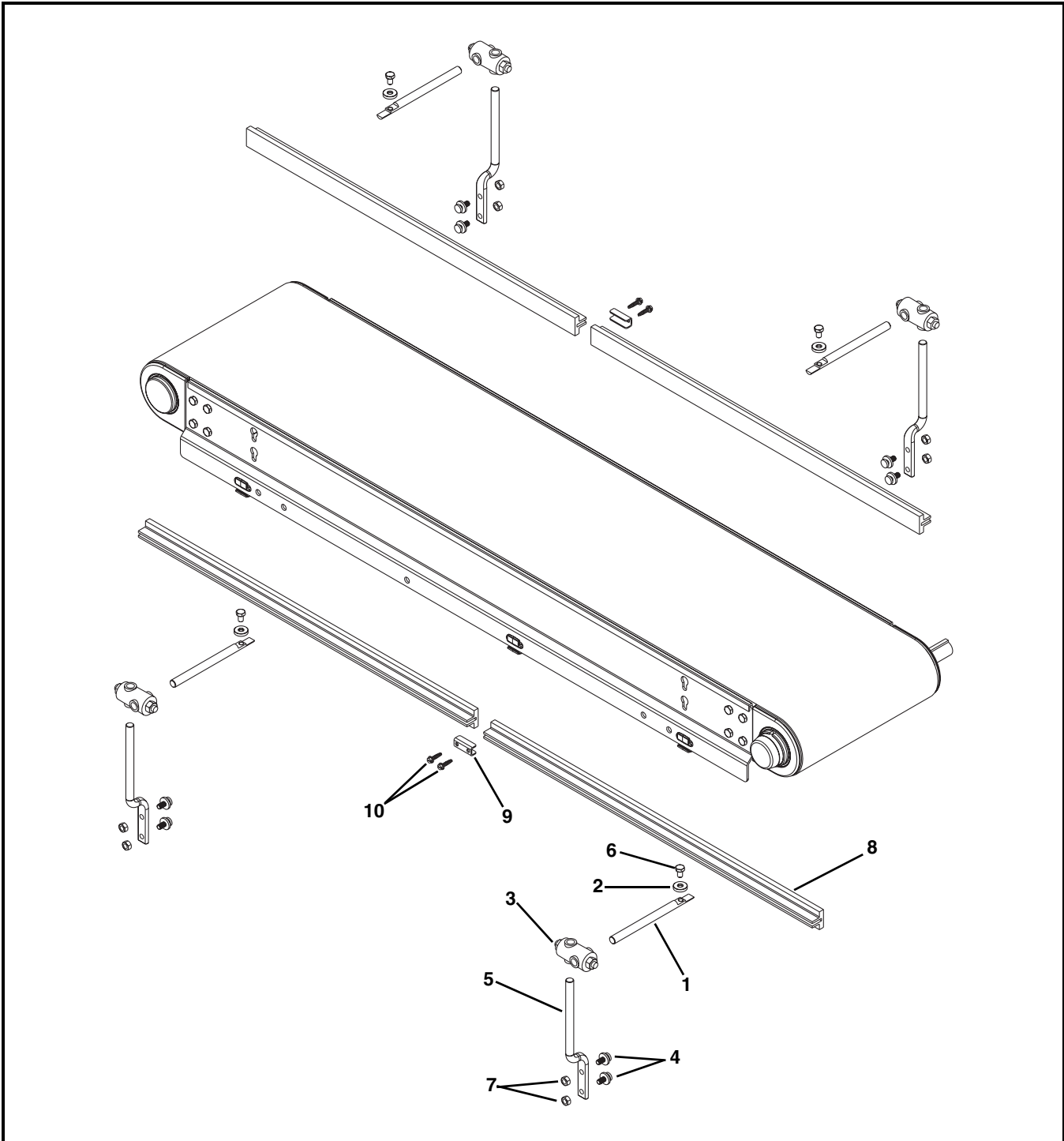

| Item | Part Number | Description |
|------|-------------|-------------------------------------|
| 1 | 532178 | Rod Clamp |
| 2 | 532179 | Washer |
| 3 | 807-1387 | Cross Block Clamp |
| 4 | 532191 | Carriage Bolt, M8 x 20 mm |
| 5 | 532192 | Offset Guide Post |
| 6 | 960812MSS | Hex Head Cap Screw, M8-1.25 x 12 mm |

| Item | Part Number | Description |
|--|----------------------|-----------------------|
| 7 | 990801MSS | Hex Nut |
| 8 | 532170- <u>LLLLL</u> | Round Guide Rail |
| 9 | 532195 | Guide Connecting Clip |
| 10 | 807-1840 | Hex Head Washer Screw |
| <u>LLLLL</u> = Length in inches with 2 decimal places. | | |
| Length Example: Length = 95.25" <u>LLLLL</u> = 09525 | | |

Tool-Less Fully Adjustable 1" (25 mm) Flat Guides

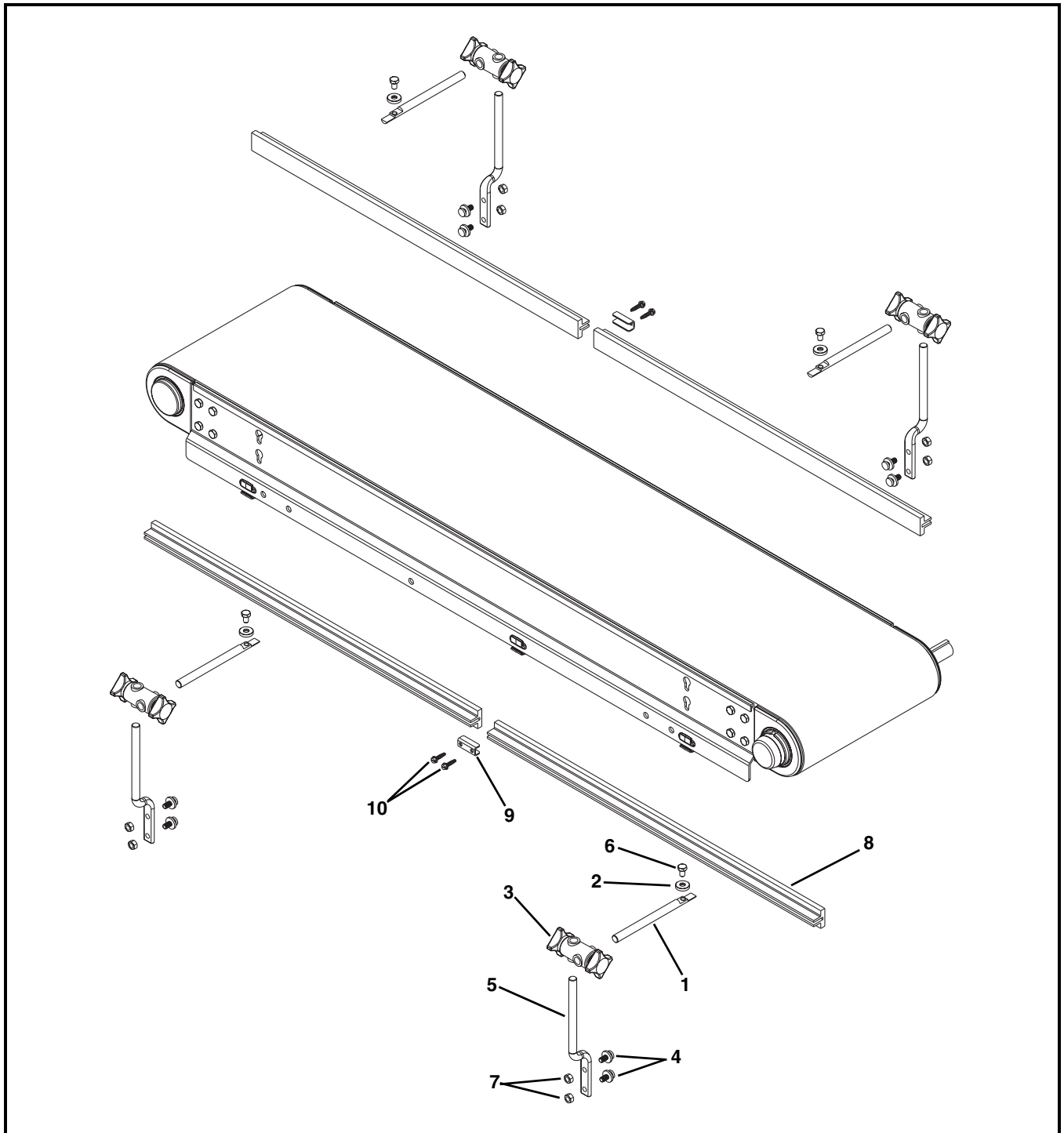

| Item | Part Number | Description |
|------|-------------|-------------------------------------|
| 1 | 532178 | Rod Clamp |
| 2 | 532179 | Washer |
| 3 | 807-1470 | Cross Block Clamp |
| 4 | 532191 | Carriage Bolt, M8 x 20 mm |
| 5 | 532192 | Offset Guide Post |
| 6 | 960812MSS | Hex Head Cap Screw, M8-1.25 x 12 mm |

| Item | Part Number | Description |
|---|--------------|-----------------------|
| 7 | 990801MSS | Hex Nut |
| 8 | 532170-LLLLL | Round Guide Rail |
| 9 | 532195 | Guide Connecting Clip |
| 10 | 807-1840 | Hex Head Washer Screw |
| LLLLL = Length in inches with 2 decimal places. | | |
| Length Example: Length = 95.25" LLLLL = 09525 | | |

Service Parts

1" (25 mm) Cleated High Sides

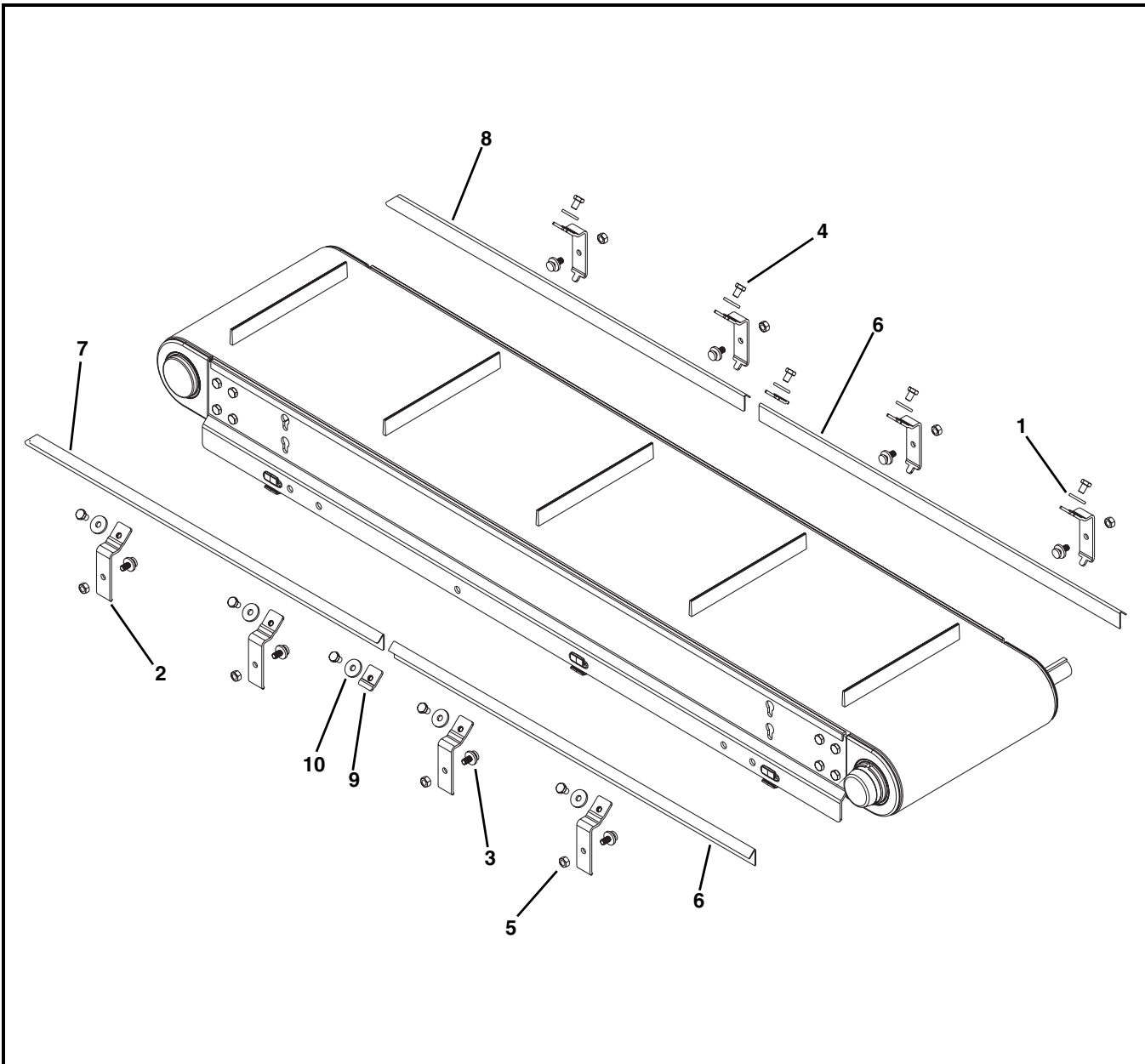

| Item | Part Number | Description |
|------|--------------|-------------------------------------|
| 1 | 807-1821 | Washer |
| 2 | 532184 | 1" Bracket |
| 3 | 532191 | Carriage Bolt, M8 x 20 mm |
| 4 | 960812M | Hex Head Cap Screw, M8-1.25 x 12 mm |
| 5 | 990801MSS | Hex Nut |
| 6 | 532175-LLLLL | Guiding Straight |

| Item | Part Number | Description |
|---|--------------|--------------------|
| 7 | 532176-LLLLL | Guiding Left Hand |
| 8 | 532177-LLLLL | Guiding Right Hand |
| 9 | 532196 | Connecting Clip |
| 10 | 807-1838 | Washer |
| LLLLL = Length in inches with 2 decimal places. | | |
| Length Example: Length = 95.25" LLLLL = 09525 | | |

3" (76 mm) Cleated High Sides

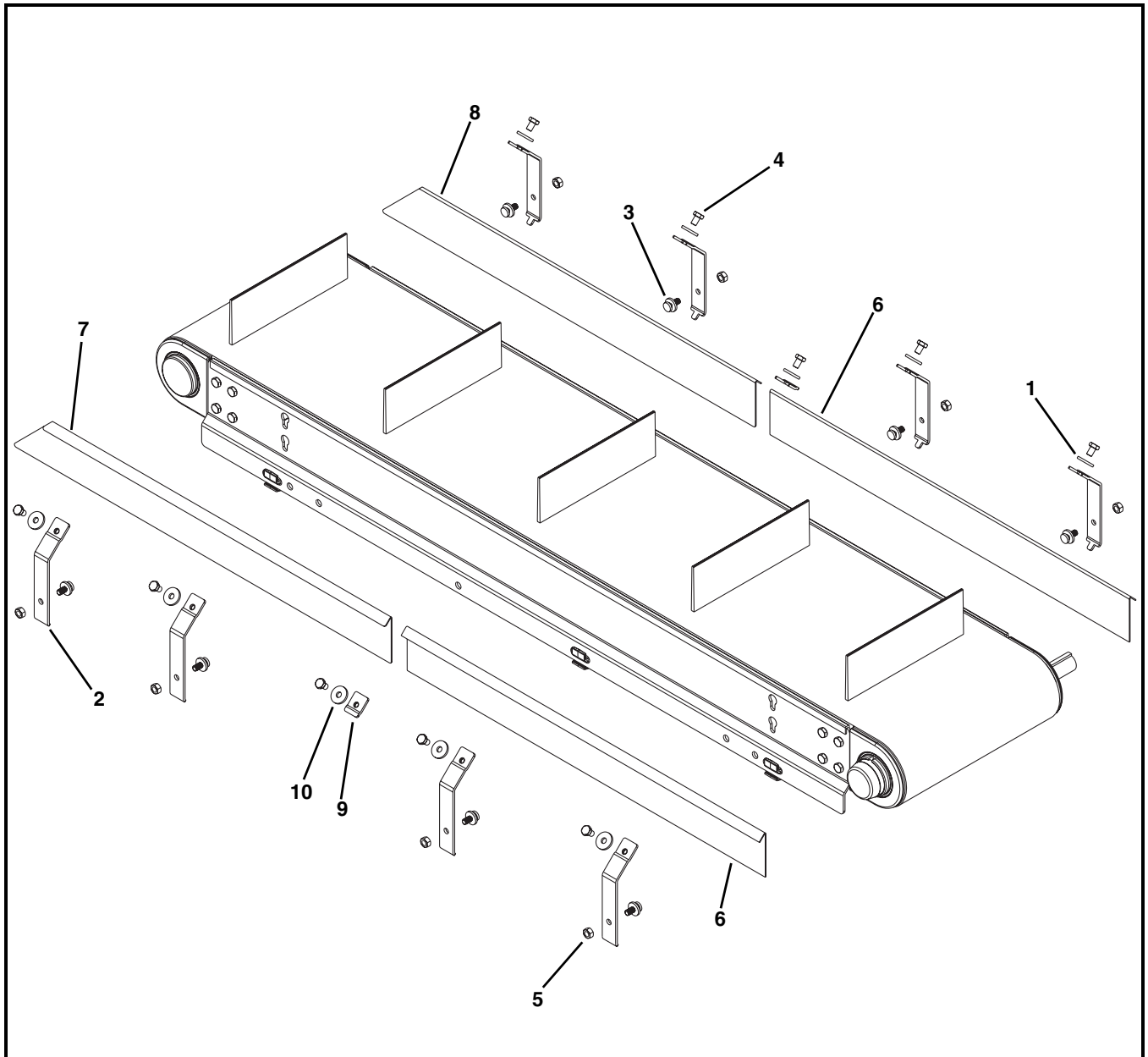

| Item | Part Number | Description |
|------|--------------|-------------------------------------|
| 1 | 807-1821 | Washer |
| 2 | 532186 | 3" Bracket |
| 3 | 532191 | Carriage Bolt, M8 x 20 mm |
| 4 | 960812M | Hex Head Cap Screw, M8-1.25 x 12 mm |
| 5 | 990801MSS | Hex Nut |
| 6 | 532172-LLLLL | Guiding Straight |

| Item | Part Number | Description |
|---|--------------|--------------------|
| 7 | 532173-LLLLL | Guiding Left Hand |
| 8 | 532174-LLLLL | Guiding Right Hand |
| 9 | 532196 | Connecting Clip |
| 10 | 807-1838 | Washer |
| LLLLL = Length in inches with 2 decimal places. | | |
| Length Example: Length = 95.25" LLLLL = 09525 | | |

Service Parts

4" (102 mm) - 24" (610 mm) Wide Returns

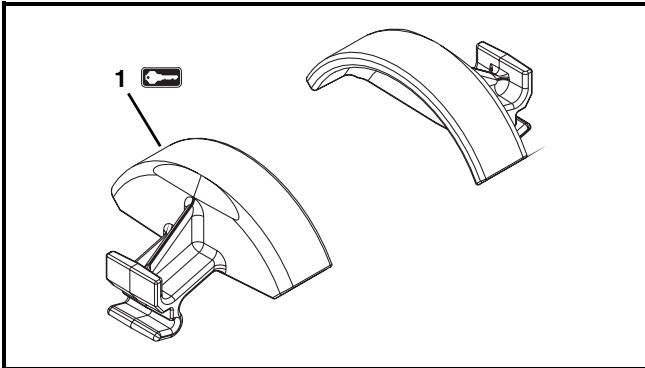

| Item | Part Number | Description |
|------|-------------|-------------|
| 1 | 532224 | Return Shoe |

26" (660 mm) - 36" (914 mm) Wide Returns

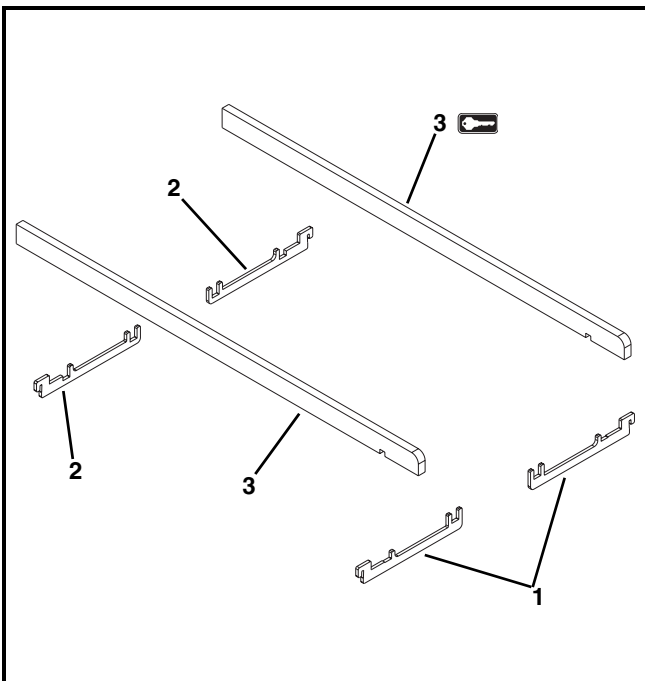

| Item | Part Number | Description |
|------|----------------------|----------------------|
| 1 | 532154 | Front Return Support |
| 2 | 532153 | Return Support |
| 3 | 532223- <u>LLLLL</u> | Wear Strips |

LLLLL = Length in inches with 2 decimal places.

Length Example: Length = 95.25" LLLLL = 09525

Ordering a Replacement Chain

Determine the length of chain required for the conveyor and round up to the nearest foot length. Order the proper number of chain repair kits (1' long each) for your conveyor. Dorner will ship chain kits that are of a reasonable length fully assembled

Example:

Overall chain length = 42' 5" (rounded up = 43')

Order: Qty (43) of 52BB-WW

BB = Chain reference number

WW = Conveyor width ref: 04-36 in 02 increments

Flat Belt Chain Repair Kit

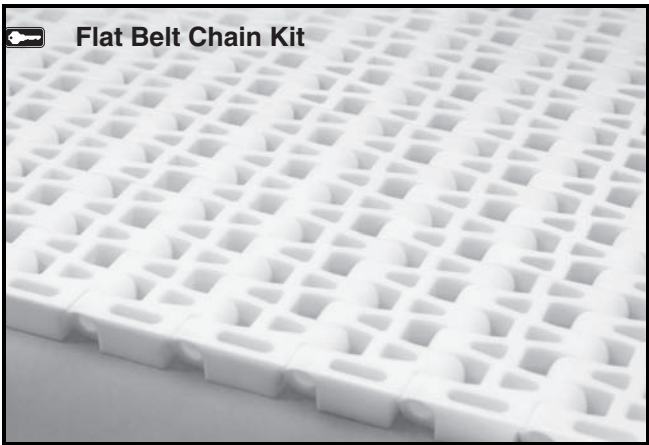

| Item | Part Number | Description |
|--|--------------------------|--|
| 1  | 52 <u>BB</u> - <u>WW</u> | Flat Belt Chain Repair Kit (Includes 1 ft (305 mm) of flat belt chain and assembly pins) |
| <u>BB</u> = Chain Reference number | | |
| <u>WW</u> = Conveyor width ref: 04 - 36 in 02 increments | | |

Cleated Belt Chain Repair Kit

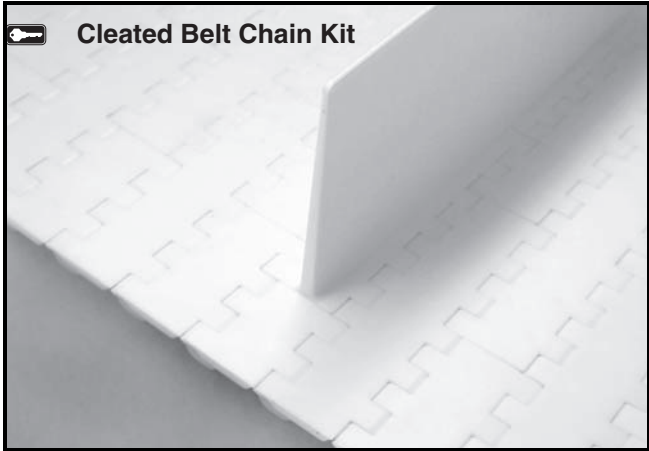

| Item | Part Number | Description |
|--|--------------------------------------|---|
| 1  | 52 <u>BB</u> - <u>WW</u> - <u>SS</u> | Cleated Belt Chain Repair Kit (Includes cleats on 1 ft (305mm) of belt chain and assembly pins) |
| <u>BB</u> = Chain Reference number | | |
| <u>WW</u> = Conveyor width ref: 08 - 24 in 02 increments | | |
| <u>SS</u> = Cleat Spacing | | |

Return Policy

Returns must have prior written factory authorization or they will not be accepted. Items that are returned to Dorner without authorization will not be credited nor returned to the original sender. When calling for authorization, please have the following information ready for the Dorner factory representative or your local distributor:

1. Name and address of customer.
2. Dorner part number(s) of item(s) being returned.
3. Reason for return.
4. Customer's original order number used when ordering the item(s).
5. Dorner or distributor invoice number (if available, part serial number).

A representative will discuss action to be taken on the returned items and provide a Returned Goods Authorization (RMA) number for reference. RMA will automatically close 30 days after being issued. To get credit, items must be new and undamaged. There will be a return charge on all items returned for credit, where Dorner was not at fault. It is the customer's responsibility to prevent damage during return shipping. Damaged or modified items will not be accepted. The customer is responsible for return freight.

Conveyors and conveyor accessories

| | |
|--|----------------------|
| Standard catalog conveyors | 30% |
| MPB, 7200, 7300 Series, cleated and specialty belt | 50% |
| AquaGard & AquaPruf Series conveyors | non-returnable items |
| Engineered to order products | case by case |
| Drives and accessories | 30% |
| Sanitary stand supports | non-returnable items |

Parts

| | |
|--|----------------------|
| Standard stock parts | 30% |
| Plastic chain, cleated and specialty belts | non-returnable items |

Returns will not be accepted after 60 days from original invoice date. The return charge covers inspection, cleaning, disassembly, disposal and reissuing of components to inventory. If a replacement is needed prior to evaluation of returned item, a purchase order must be issued. Credit (if any) is issued only after return and evaluation is complete.

Dorner has representatives throughout the world. Contact Dorner for the name of your local representative. Our Customer Service Team will gladly help with your questions on Dorner products.

For a copy of Dorner's Warranty, contact factory, distributor, service center or visit our website at www.dorner.com.

For replacement parts, contact an authorized Dorner Service Center or the factory.



Dorner Mfg. Corp. reserves the right to change or discontinue products without notice. All products and services are covered in accordance with our standard warranty. All rights reserved. © Dorner Mfg. Corp. 2009

DORNER MFG. CORP.

975 Cottonwood Ave., PO Box 20
Hartland, WI 53029-0020 USA
TEL 1-800-397-8664 (USA)
FAX 1-800-369-2440 (USA)
Internet: www.dorner.com

Outside the USA:
TEL 1-262-367-7600
FAX 1-262-367-5827