

4100 Series End Drive Conveyors

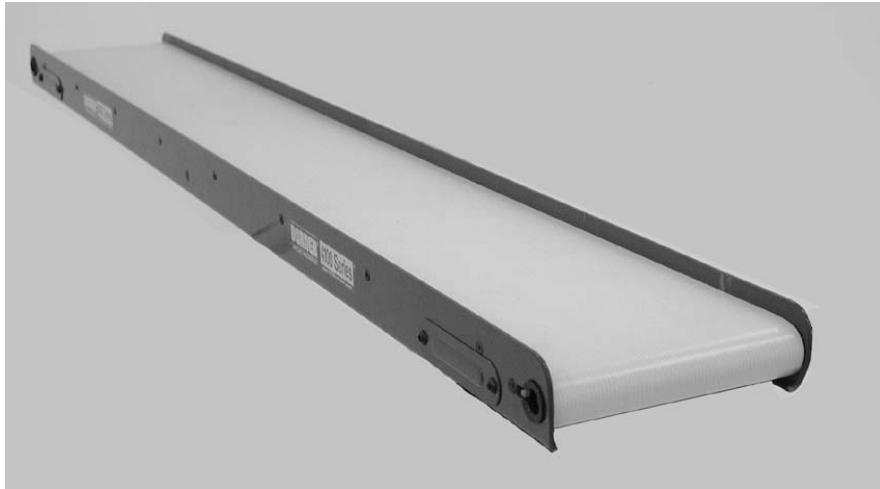



Table of Contents



Warnings – General Safety	2	Tension Pin Removal	8
Introduction	2	Tension Pin Installation	9
Product Description	3	Outboard Drive Shaft Replacement	10
Specifications	3	Outboard Drive Shaft Removal	10
Installation	4	Outboard Drive Shaft Installation	11
Recommended Installation Sequence	4	Pulley Replacement	11
Conveyors Up to 13 ft (3962 mm)	4	Pulley Removal	12
Preventive Maintenance & Adjustment	5	Pulley Installation	12
Required Tools	5	1" (25mm) – 3" (76mm) Wide Pulleys	12
Standard Tools	5	4" (95mm) – 12" (305mm) Wide Pulleys	14
Special Tools	5	Return Belt Roller Replacement	16
Checklist	5	Return Belt Roller Removal	16
Lubrication	5	Return Belt Roller Installation	16
Conveyor Pulley Bearings	5	Pulley Bearing Replacement	16
Idle Pulley Bearings	5	Pulley Bearing Removal	16
Drive Pulley Bearings	5	Pulley Bearing Installation	16
Conveyors with Top or Bottom Mounting Package	7	Tension Pin Bearing Replacement	17
Conveyors with Side Mounting Package	7	Service Parts	18
Conveyors with Side Mounting Package –		4100 Series Conveyor Assembly	18
Light Load Gearmotor	7	Mounting Brackets and Outboard Drive Shaft	20
Maintaining Conveyor Belt	7	–03 Side Wiper	21
Troubleshooting	7	–07 Low to Side Wiper	21
Cleaning	8	–09 Low to High Side	22
Conveyor Belt Replacement	8	Hinged Side Guide	22
Conveyor Belt Replacement Sequence	8	Abrasion Shield	23
Conveyor Belt Removal	8	Conveyor Belt Part Number Configuration	23
Conveyor Belt Installation	8	Return Policy	24
Conveyor Belt Tensioning	8		

Warnings – General Safety

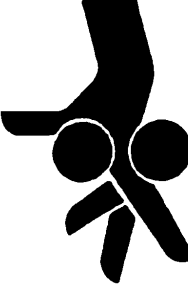

	WARNING	
<p>The safety alert symbol, black triangle with white exclamation, is used to alert you to potential personal injury hazards.</p>		

		WARNING
<p>Gearmotors may be HOT. DO NOT TOUCH Gearmotors.</p>		

		DANGER
<p>Climbing, sitting, walking or riding on conveyor will cause severe injury. KEEP OFF CONVEYORS.</p>		

		WARNING
<p>Dorner cannot control the physical installation and application of conveyors. Taking protective measures is the responsibility of the user.</p> <p>When conveyors are used in conjunction with other equipment or as part of a multiple conveyor system, CHECK FOR POTENTIAL PINCH POINTS and other mechanical hazards before system start-up.</p>		

		DANGER
<p>DO NOT OPERATE CONVEYORS IN AN EXPLOSIVE ENVIRONMENT.</p>		

		WARNING
<p>Exposed moving parts can cause severe injury. LOCK OUT POWER before removing guards or performing maintenance.</p>		

		WARNING
<p>Loosening stand height or angle adjustment screws may cause conveyor sections to drop down, causing severe injury. SUPPORT CONVEYOR SECTIONS PRIOR TO LOOSENING STAND HEIGHT OR ANGLE ADJUSTMENT SCREWS.</p>		

Introduction

IMPORTANT: Some illustrations may show guards removed. DO NOT operate equipment without guards.

Upon receipt of shipment:

- Compare shipment with packing slip. Contact factory regarding discrepancies.
- Inspect packages for shipping damage. Contact carrier regarding damage.
- Accessories may be shipped loose. See accessory instructions for installation.

Dorner's Limited Warranty applies.

Dorner 4100 series conveyors are covered by Patent No. 5174435 and corresponding patents and patent applications in other countries.

Dorner reserves the right to make changes at any time without notice or obligation.

Dorner has convenient, pre-configured kits of Key Service Parts for all conveyor products. These time saving kits are easy to order, designed for fast installation, and guarantee you will have what you need when you need it. Key Parts and Kits are marked in the Service Parts section of this manual with the Performance Parts Kits logo .

Product Description

Refer to Figure 1 for typical conveyor components.

Typical Components	
A	Conveyor
B	Gearmotor Mounting Package
C	Gearmotor
D	Guiding & Accessories
E	Mounting Brackets
F	Support Stand
G	Variable Speed Controller
H	Drive End
I	Idler/Tension End

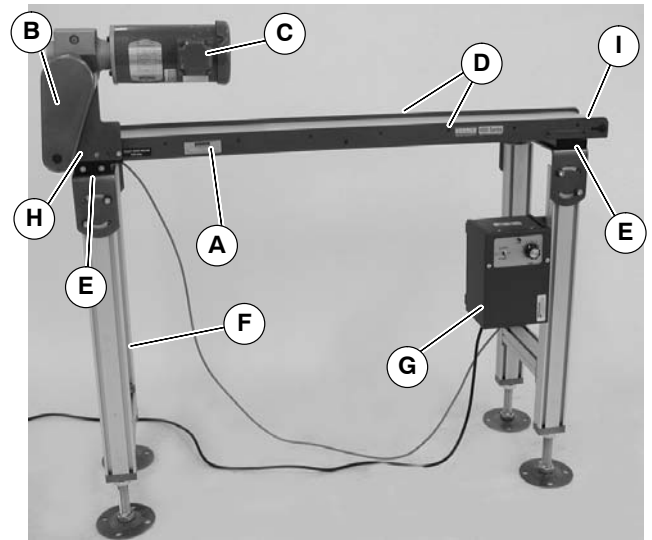
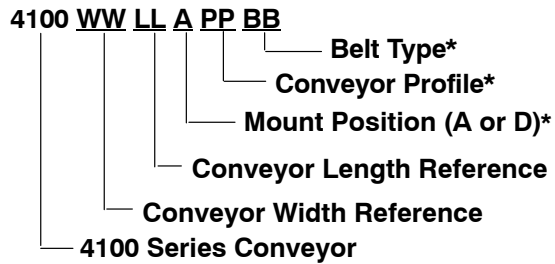

Figure 1

Specifications

Models:

4100 Series End Drive Conveyor



* See Ordering and Specifications Catalog for Details

Conveyor Supports:

Maximum Distances:

J = 18" (457 mm)**

K = 6 ft (1829 mm)

L = 18" (457 mm)

** For Heavy Load Bottom Mount Package, mount support under gear head.

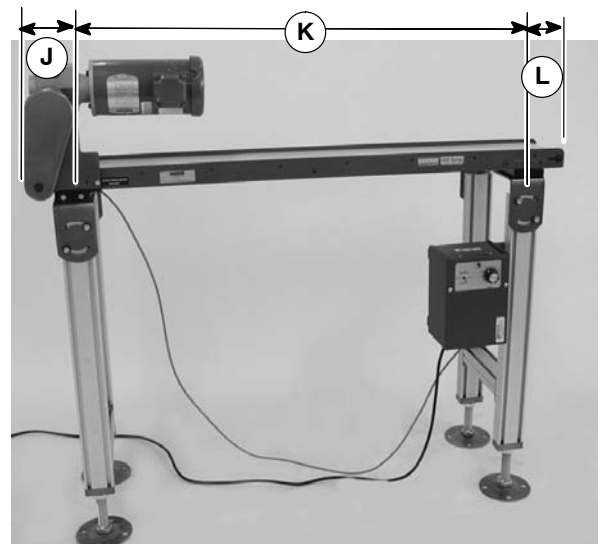

Figure 2

Specifications

Specifications:

Conveyor Width Reference (WW)	01	02	03	04	06	08	12
Conveyor Belt Width	0.75" (19mm)	1.75" (44mm)	2.75" (70mm)	3.75" (95mm)	6" (152mm)	8" (203mm)	12" (305mm)
Maximum Conveyor Load* (See NOTE Below)	25 lbs (12 kg)	30 lbs (14 kg)	35 lbs (16 kg)	42 lbs (19 kg)	60 lbs (27 kg)	70 lbs (32 kg)	80 lbs (36 kg)
Conveyor Start-up Torque*	3 in-lb (.3 Nm)	4 in-lb (0.5 Nm)	5 in-lb (0.6 Nm)	6 in-lb (0.7 Nm)	8 in-lb (0.9 Nm)	10 in-lb (1.1 Nm)	14 in-lb (1.4 Nm)
Belt Travel	3.4" (86mm) per revolution of pulley						
Maximum Belt Speed*	235 feet/minute (72 meters/minute)						

Conveyor Length Reference (LL)	02	03	04	05	06
Conveyor Length	2' (610mm)	3' (914mm)	4' (1,219mm)	5' (1,524mm)	6' (1829mm)

* See Ordering and Specifications Catalog for details.

NOTE: Maximum conveyor loads based on:

- Non-accumulating product
- Product moving towards gearmotor
- Conveyor being mounted horizontal

Installation

NOTE: Conveyor **MUST** be mounted straight, flat and level within confines of conveyor. Use a level (M of Figure 3) for setup.



Figure 3

Recommended Installation Sequence

- Install support stands (see accessory instructions)
- Attach conveyor to stands
- Mount gearmotor mounting package (see accessory instructions)
- Attach guides/accessories (see "Service Parts" section, page 18 through 22)

Preventive Maintenance and Adjustment

Required Tools

Standard Tools

- Hex-key wrenches:
5/64", 3/32" (2x), 3/16", 5/32", 1/8", 7/64"
- Arbor press
- Manual grease gun
- Adjustable wrench

Special Tools

- 4500 Tool Kit for 4100 Series Conveyor

Checklist

- Keep service parts on hand (see "Service Parts" section for recommendations)
- Keep supply of belt cleaner (part #625619)
- Clean entire conveyor and knurled pulley while disassembled
- Replace worn or damaged parts

Lubrication

Pulley Bearings



NOTE: Lubricate pulley bearings every 750 hours or more frequently, depending on operating conditions. When lubricating pulley bearings, use a conventional hand grease gun with a maximum of one pump per application. *Do not over-lubricate.* Do not use a power grease gun.

NOTE: Lubricate bearings using Dornier red grease 14oz. cartridge (829-002) or 14oz. can (829-003)

1" (25mm) – 2" (51mm) Wide Pulley Bearings

No lubrication is required. Replace pulley when bearings are worn.

Non-Drive Position – 3" (76mm) and Wider Conveyors

1. Remove plastic plug (N of Figure 4).



Figure 4

2. Install greasing adapter (45-12, part of tool kit 4500) (O of Figure 5). Make sure the adapter shoulder is seated against the conveyor frame.

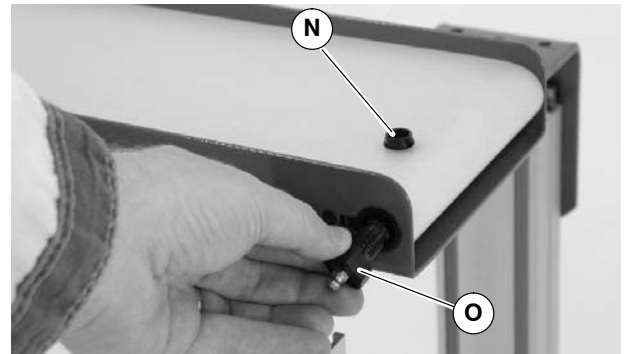

Figure 5

3. Lubricate bearing using Dornier Red Grease 14oz. cartridge (829-002) or 14oz. can (829-003). Use a conventional hand grease gun with a maximum of one pump per application. *Do not over-lubricate.* Do not use a power grease gun.
4. Grease adapter (O) can be left attached, or removed and replaced with plastic plug (N of Figure 4).

Drive Position - 3" (70mm) and Wider Conveyors

Conveyors with Top or Bottom Mounting Package

1. Remove plug (P of Figure 6) from belt guard (Q).



Figure 6

Preventive Maintenance and Adjustment

2. Lubricate pulley bearing through outboard drive shaft grease fitting (R of Figure 7).



Figure 7

3. When lubricating pulley bearings for first time, outboard retaining sleeve must be filled with grease before bearings will get any lubrication. Use a maximum of two pumps. **Do not over-lubricate.**
4. When lubricating pulley bearings anytime after initial lubrication, use a maximum of one pump per application. **Do not over-lubricate.**
5. Replace plug (P of Figure 6).

Conveyors with Side Mounting Package

1. Locate the drive shaft grease fitting (S of Figure 8). Lubricate pulley bearings through the grease fitting.

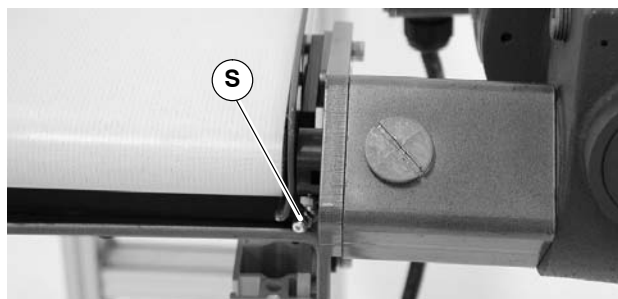

Figure 8

2. When lubricating pulley bearings for the first time, outboard retaining sleeve must be filled with grease before the bearings will get any lubrication. Use a maximum of two pumps. **Do not over-lubricate.**
3. When lubricating pulley bearings anytime after initial lubrication, use a maximum of one pump per application. **Do not over-lubricate.**

Conveyors with Side Mounting Light Load Gearmotor Package

1. Loosen two (2) mounting package mounting screws (T of Figure 9).

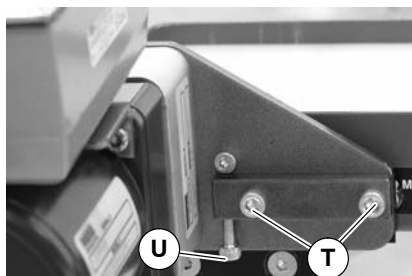

Figure 9

2. Loosen timing belt tension screw (U).
3. Remove (4) motor mounting screws (V). Remove gearmotor and timing belt

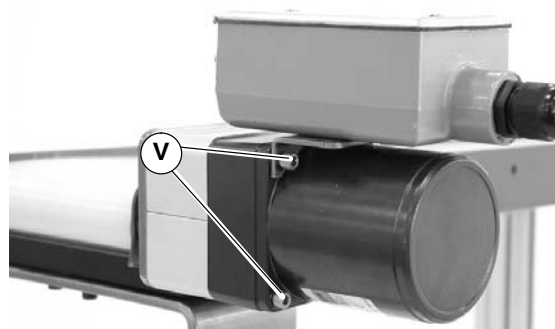

Figure 10

4. Loosen (2) set screws (W of Figure 11) on timing belt pulley (X).

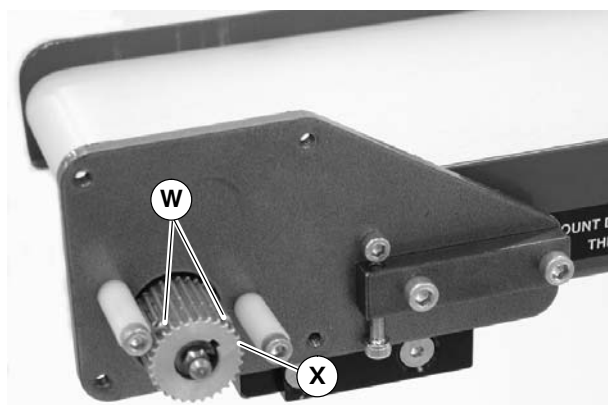

Figure 11

5. Remove timing belt pulley (X).

Preventive Maintenance and Adjustment

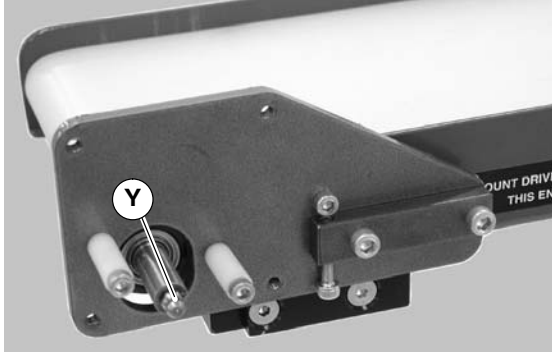

Figure 12

6. Lubricate pulley bearing on drive side through drive shaft grease fitting (Y of Figure 12).
7. When lubricating pulley bearings for first time, outboard retaining sleeve must be filled with grease before bearings will get any lubrication. Use a maximum of two pumps. **Do not over-lubricate.**
8. When lubricating pulley bearings anytime after initial lubrication, use a maximum of one pump per application. **Do not over-lubricate.**
9. Reinstall side mount drive package by following steps 4 through 1 in reverse order.

Maintaining Conveyor Belt

Troubleshooting

Inspect conveyor belt for:

- Surface cuts or wear
- Stalling or slipping
- Tracking problems;
- Worn edges;
- Stretching or breaking;
- Belts that walk to one side;
- Non-uniform movement of conveyor belt;
- Lines or rough edges on belt;

Surface cuts or wear indicates:

- Sharp or heavy parts impacting belt
- Jammed parts
- Improperly installed bottom wipers (if installed)
- Accumulated dirt in wipers (if installed)
- Foreign material inside the conveyor
- Improperly positioned accessories
- Bolt-on guiding is pinching belt

Stalling or slipping indicates:

- Excessive load on belt

- Conveyor belt or drive timing belt are not properly tensioned
- Worn knurl or impacted dirt on drive pulley
- Intermittent jamming or drive train problems

Tracking problems indicate:

- Pulleys not installed correctly
- Frame misalignment
- Twisted or damaged conveyor frame
- Jammed part

Worn edges indicate:

- Dirt accumulating on pulleys
- Belt tracking incorrectly

Belts that walk to one side indicate:

- Twisted or damaged conveyor frame;
- Dirt accumulating on outside diameter of pulleys;
- Side load on belt;
- Improper load/unload of parts on conveyor;

Non-uniform movement indicates:

- Belt slippage due to inadequate conveyor belt or timing belt tension.
- Belt slippage due to excessive load on conveyor belt.
- Intermittent jam or drive train problems.

Lines or rough edges on belt could indicate:

- Jammed part;
- Accumulated dirt in wipers;
- Foreign material inside conveyor;
- Improper position of accessories.

NOTE: Visit www.dorner.com for complete list of troubleshooting solutions.

Cleaning

IMPORTANT: Do not use belt cleaners that contain alcohol, acetone, Methyl Ethyl Ketone (MEK) or other harsh chemicals.

Use Dorner Belt Cleaner (part #625619). Mild soap and water may also be used. Do not soak the belt.

For /05 woven polyester and /06 black anti-static belts, use a bristled brush to improve cleaning.

Preventive Maintenance and Adjustment

Conveyor Belt Replacement

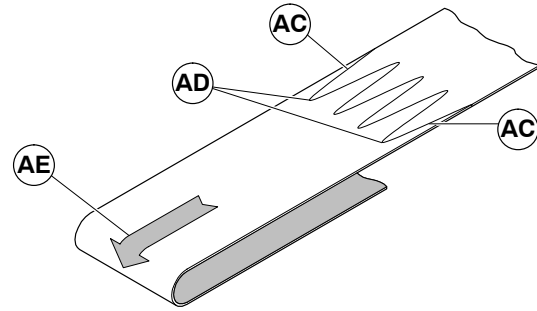
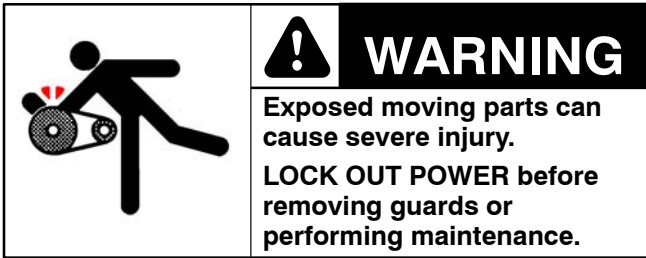

Figure 15

Conveyor Belt Removal

1. Remove tension pin assemblies. See “Tension Pin Removal” section on page 8.
2. If equipped, remove outboard drive shaft. See “Outboard Drive Shaft Removal” section on page 10.
3. Remove drive/idler pulley. See “Pulley Removal” section on page 12.
4. Remove screws (Z of Figure 13) on both sides of conveyor and remove bed plate (AB).

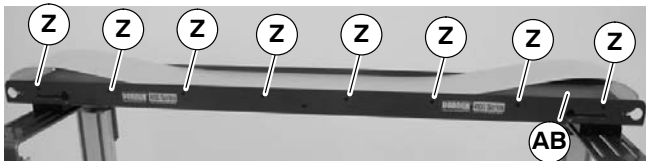

Figure 13

5. Remove belt (AA of Figure 14) from bed plate (AB).

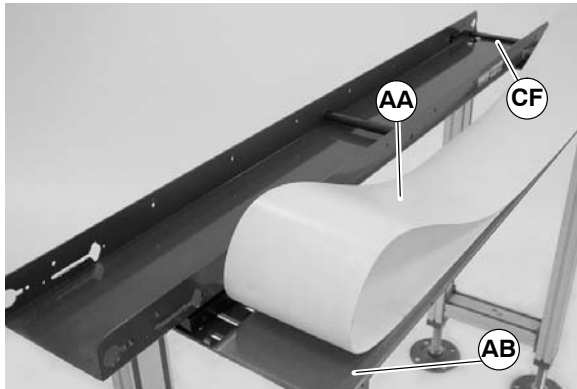

Figure 14

Conveyor Belt Installation

1. Insert belt (AA of Figure 14) inside frame. Orient belt so belt splice leading finger (AD of Figure 15) points in direction of travel (AE) and trailing finger (AC) is as shown. Belt must run toward bottom wiper (CF of Figure 14).

2. Insert bedplate (AB of Figure 14) inside belt loop.
3. Attach bedplate (AB of Figure 14) to conveyor frame with screws (Z of Figure 13). Tighten screws to 14 in-lbs.
4. Install drive/idler pulleys. See “Pulley Installation” section on page 12.
5. Install tension pins. See “Tension Pin Installation” section on page 10.

Conveyor Belt Tensioning



Tension Pin Removal

- 1a. Remove screws (AF of Figure 16) and tension pin covers (AG) on both sides of conveyor.

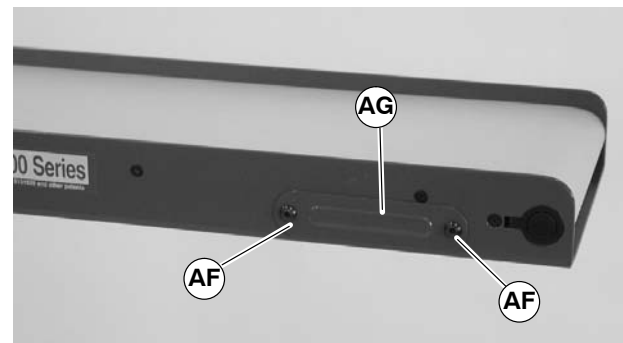

Figure 16

- 1b. If tension pins are located on drive side, remove gearmotor mount. Remove screws (AI of Figure 17) and mounting plate (AH).

Preventive Maintenance and Adjustment

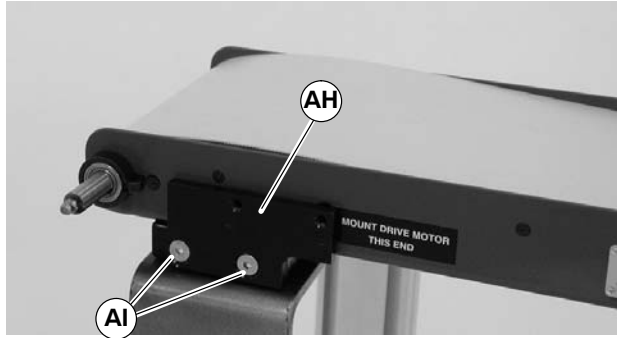

Figure 17

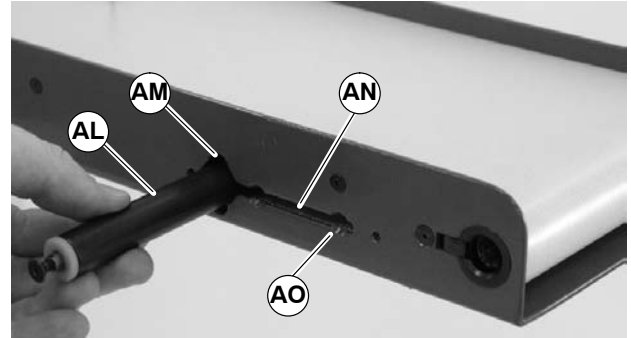

Figure 20

- Using two (2) hex key wrenches, loosen but do not remove screw (AJ of Figure 18). Back the screw out approximately 3/16".

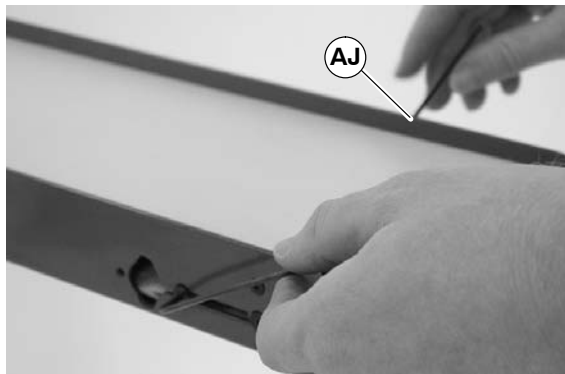

Figure 18

- Push on loose screw (AJ of Figure 18) to engage shaft flats with conveyor countersink holes (AO) on slot. Loosen other screw (AK of Figure 19).

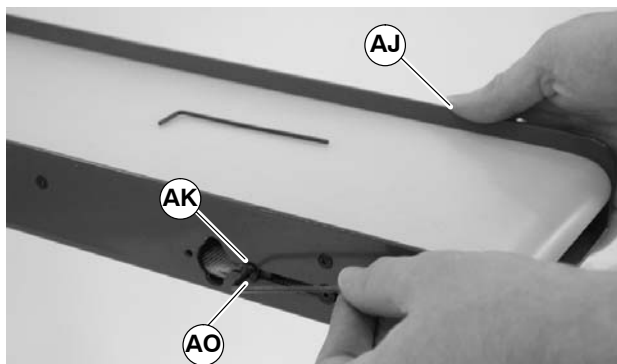

Figure 19

- Slide tension pin assembly (AL of Figure 20) along slot (AN) to hole in frame (AM). Remove tension pin assembly (AL) through hole.

Tension Pin Installation

NOTE: Belt tension can be applied in three different settings (A, B or C, Figure 21) for tension adjustment.

Minimum Tension (A) – Factory-set tension. Used for new conveyor belts. Both tension pin assemblies are installed above return belt.

Intermediate Tension (B) - Install both tension pin assemblies under return belt.

Maximum Tension (C) - Install tension pin assembly under return belt and secure through countersink holes closest to end of frame. Install second tension pin assembly above return belt and secure in other countersink holes.

NOTE: Tension pin assemblies are found at bottom wiper end of conveyor. Additional tension can be achieved by installing a second set of tension pins on opposite end of conveyor.

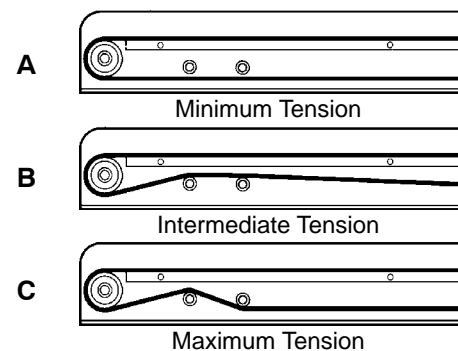

Figure 21

Preventive Maintenance and Adjustment

1. Locate tension versus conveyor belt as required for tension setting (A, B or C of Figure 21). Insert tension pin assembly (AL of Figure 22) into conveyor frame through hole (AM).

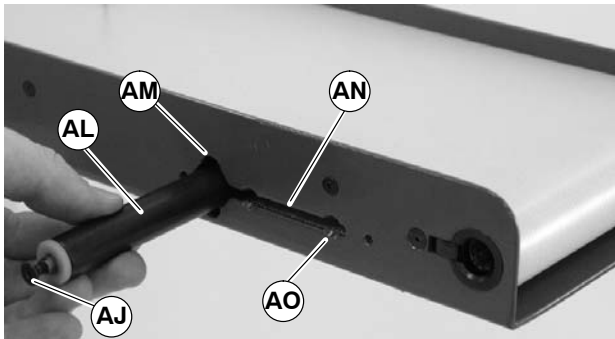

Figure 22

2. Slide assembly (AL) along slot (AN) until screws (AJ) line up with countersink holes (AO) on slot.
3. Reverse steps 1 through 3 of “Tension Pin Removal” section. Make sure that screws are properly seated in countersink holes.

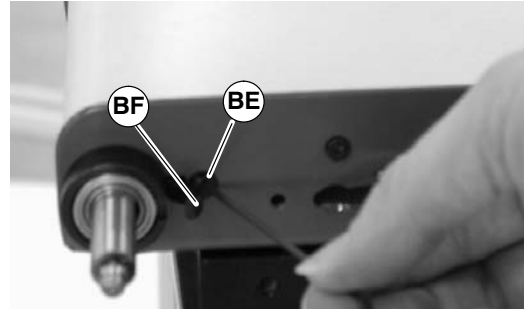

Figure 24

3. Remove retaining clip (BF) and screw (BE).
4. Insert small end of hex key wrench extension tool (AP of Figure 25) (25-08, part of tool kit 4500) into pulley end opposite outboard drive shaft.
5. Loosen and remove wave washer (AU of Figure 25), flat washer (AV) and pulley screw (AW) with hex key wrench extension tool (AP).

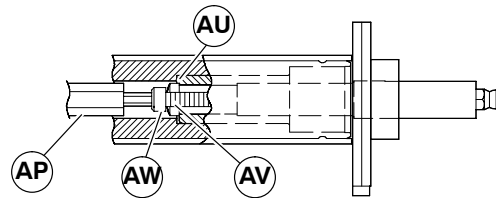

Figure 25

Outboard Drive Shaft Replacement



Outboard Drive Shaft Removal

1. Remove plastic plug (N of Figure 23)



Figure 23

2. Loosen but do not remove screw (BE of Figure 24). Push until pulley retaining sleeve clip (BF) pushes out.

6. Pull outboard drive shaft (AQ of Figure 26) and outboard bearing retaining sleeve (AR) from drive pulley.



Figure 26

7. Push outboard drive shaft (AQ) through outboard bearing retaining sleeve (AR).

Preventive Maintenance and Adjustment

Outboard Drive Shaft Installation

NOTE: Hex bore is off center on pulleys for conveyors measuring 5" (127 mm) and wider. Locate drive shaft or hex bore side. Drive pulley may have to be turned around.



1. Install outboard drive shaft (AQ of Figure 27) and outboard bearing retaining sleeve (AR).

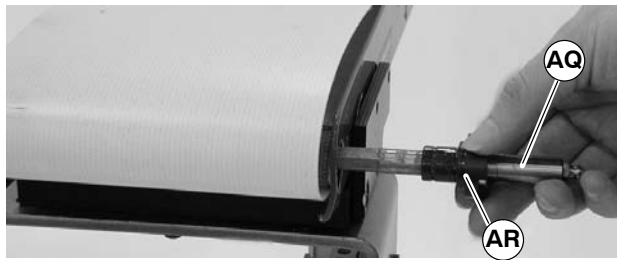

Figure 27

2. Place pulley screw (AW of Figure 28), wave washer (AU) and flat washer (AV) onto small end of hex key wrench extension tool (AP of Figure 28) (25-08).

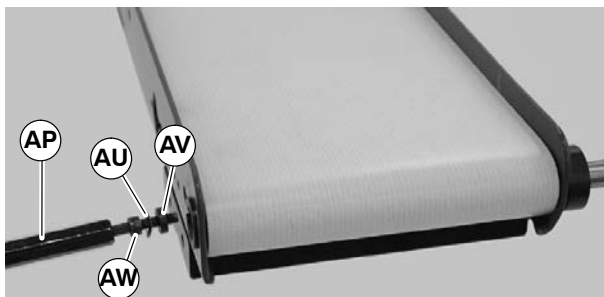

Figure 28

3. Insert small end of hex key wrench extension tool (AP of Figure 29) into pulley end opposite the outboard drive shaft (AQ) and tighten pulley screw (AW) to 20in/lb. Back off screw exactly 1/2 turn (180°).

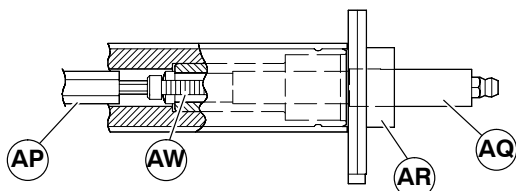

Figure 29

NOTE: Failure to back off pulley screw 1/2 turn will cause premature failure of screw.

4. Align slot (AX) in outboard bearing retaining sleeve (AR) with slot (AY) in conveyor frame.

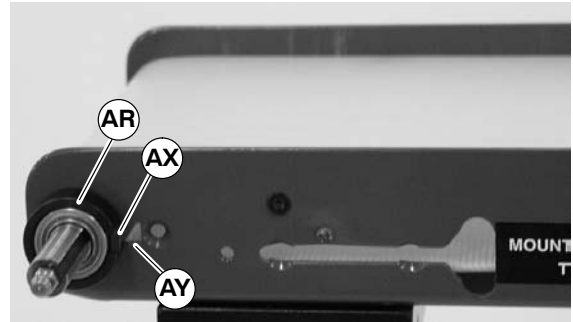

Figure 30

5. Insert retaining sleeve clip (BF) into slot (AY). Tighten with screw (BE).

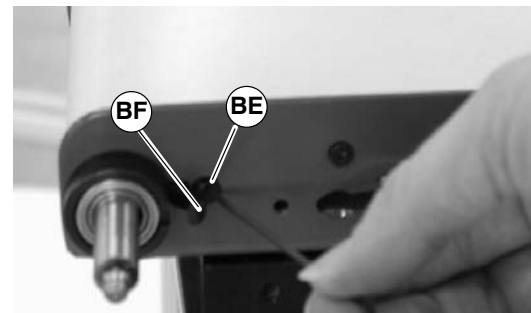
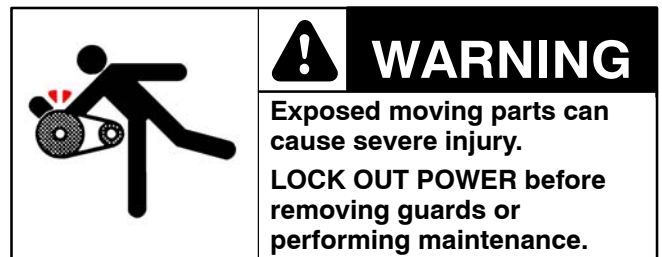

Figure 31

6. Replace plastic plug (N of Figure 23).

Pulley Replacement



NOTE: If equipped, Outboard Drive Shaft must be removed in order to remove drive pulley. See "Outboard Drive Shaft Removal" section on page 10.

Preventive Maintenance and Adjustment

Pulley Removal

1. Remove screws (AF of Figure 32) and tension pin cover (AG) and plastic plug (N).

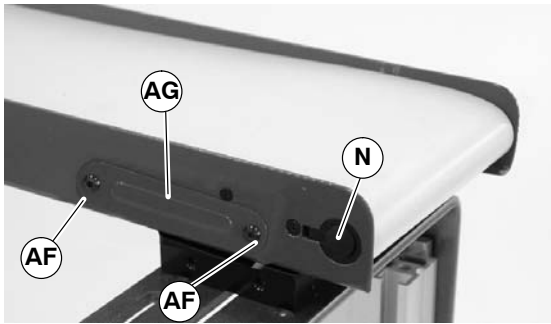

Figure 32

2. Remove tension pin assemblies. See “Tension Pin Removal” section on page 8.
3. Loosen but do not remove screw (AZ of Figure 33). Push until pulley retaining sleeve clip (BA) pushes out.

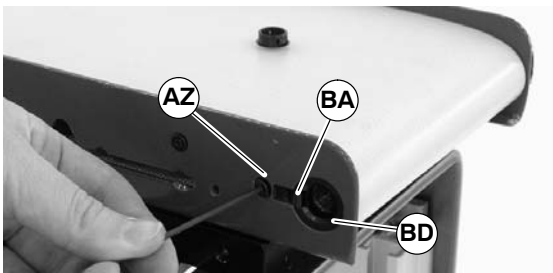

Figure 33

4. Remove retaining clip (BA) and screw (AZ).
5. Position bearing anvil/sleeve removal tool (BB of Figure 34) (25-09, part of tool kit 4500) over retaining sleeve (BD of Figure 33).

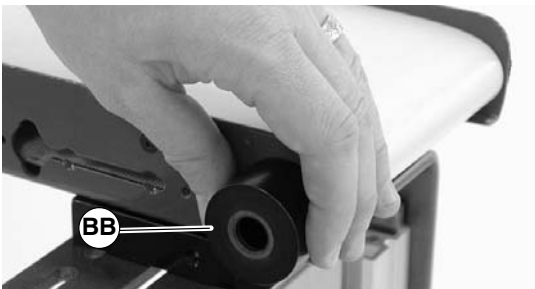

Figure 34

6. Insert bolt (BC of Figure 35) (906-278, part of tool kit 4500) into retaining sleeve (BD of Figure 33).

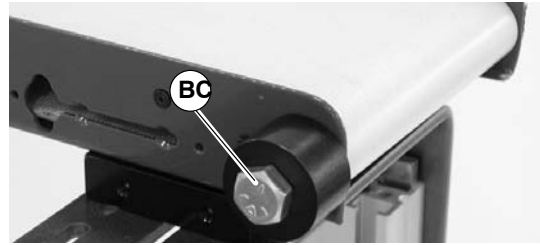

Figure 35

7. Turn bolt (BC) until retaining sleeve (BD of Figure 36) separates from pulley (BI). Remove retaining sleeve (BD).

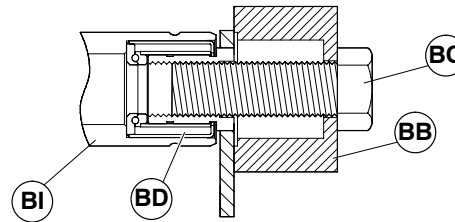

Figure 36

8. Repeat steps 3 through 7 for retaining sleeve on opposite side of conveyor.
9. Remove pulley (BI of Figure 37).

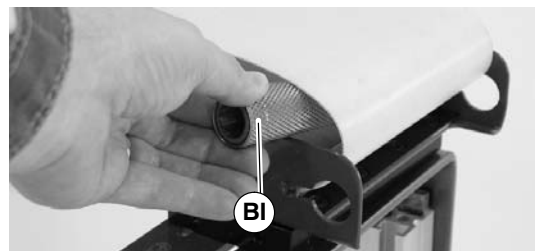

Figure 37

Pulley Installation

1" (25mm) – 3" (76mm) Wide Pulleys

		<h3>WARNING</h3>
	<p>Exposed moving parts can cause severe injury. LOCK OUT POWER before removing guards or performing maintenance.</p>	

1. Insert pulley (BI of Figure 38) inside belt loop.

Preventive Maintenance and Adjustment

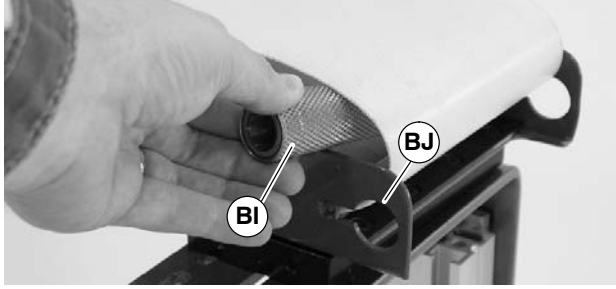

Figure 38

2. Insert sleeve arbor tool (BK of Figure 39) (45-02, part of tool kit 4500).

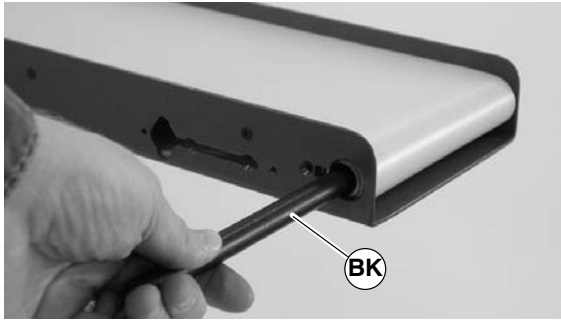

Figure 39

3. Using sleeve arbor tool (BK) as a lever, align pulley bore (BI) with holes in conveyor frame (BJ).

IMPORTANT: Do not hit retaining sleeve (BD of Figure 40) with hammer or any other tool when installing. Inspect frame bore for damage or out of roundness if retaining sleeve does not slide easily into place. Frames with worn holes should be replaced.

4. Insert retaining sleeve (BD of Figure 40) into pulley (BI). Push in until inside surface of retaining sleeve (BL) shoulder touches outside of frame (BM). Do not push shoulder of retaining sleeve into frame opening.

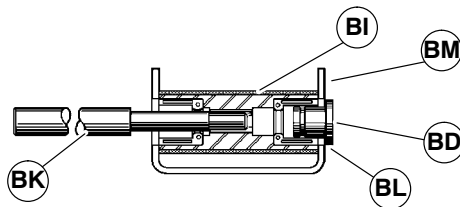

Figure 40

5. Remove the sleeve arbor tool (BK of Figure 41) and insert it into opposite side through retaining sleeve (BD).

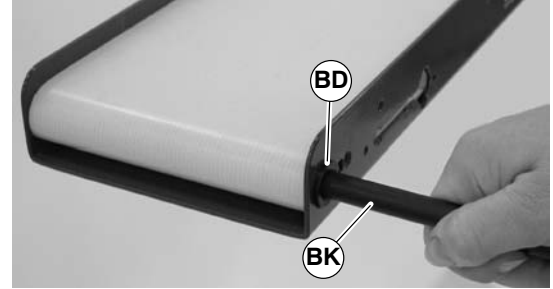

Figure 41

6. Using sleeve arbor tool (BK) as a lever, align pulley bore with conveyor frame opening.
7. Insert retaining sleeve (BD of Figure 42) into pulley (BI) until flush with conveyor frame (BM).

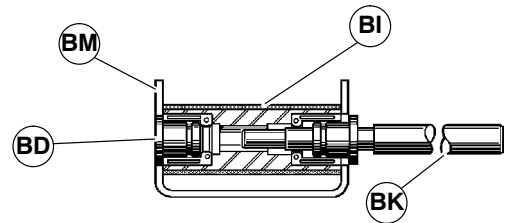

Figure 42

8. Insert sleeve arbor tool (BK of Figure 43) into opposite side of conveyor.

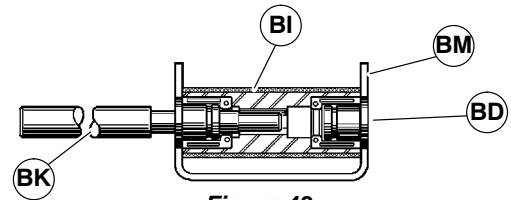

Figure 43

9. Using sleeve arbor tool (BK) as a lever, push the retaining sleeve (BD) fully in.
10. Align slot (BO of Figure 44) in retaining sleeve (BD) with slot in conveyor frame (BP).

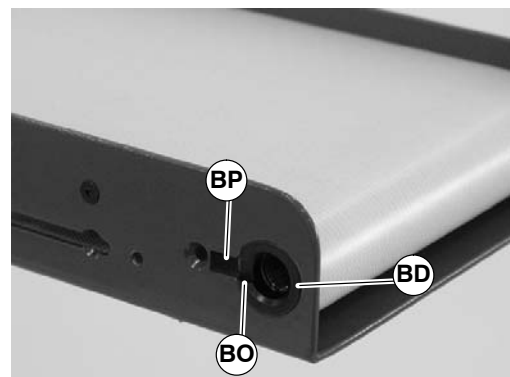

Figure 44

Preventive Maintenance and Adjustment

11. Insert retaining sleeve clip (BA of Figure 45) into slot and tighten with screw (AZ).

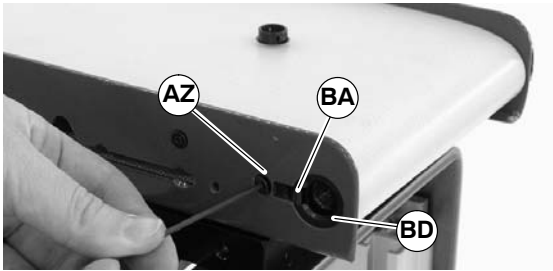

Figure 45

12. Install plastic plug (N of Figure 46).

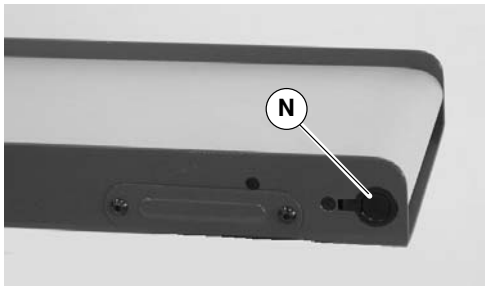

Figure 46

13. Repeat steps 10 through 12 on opposite side of conveyor.

4" (95 mm) – 12" (305 mm) Wide Pulleys

	<p>! WARNING</p> <p>Exposed moving parts can cause severe injury.</p> <p>LOCK OUT POWER before removing guards or performing maintenance.</p>
--	---

NOTE: Hex bore is off center on pulleys 5" (127mm) and wider. When pulley is used with a top or bottom mounting package, hex bore must be located towards drive side. On conveyors equipped with motion monitor sensor switch (or when installing sensor switch), hex bore must be located towards switch side of conveyor.

1. Insert pulley (BI of Figure 47) inside belt loop.

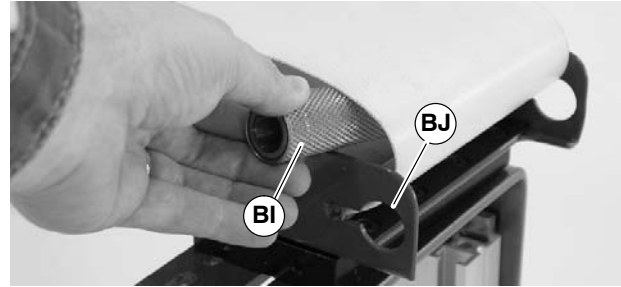

Figure 47

2. Insert pulley installation tool (BQ of Figure 48) (25-07, part of tool kit 4500) into conveyor frame.

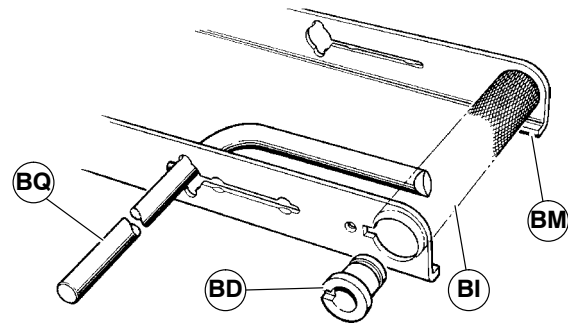

Figure 48

3. Using pulley installation tool (BQ of Figure 49) as a lever, align pulley bore (BI) with hole (BJ) in conveyor frame.

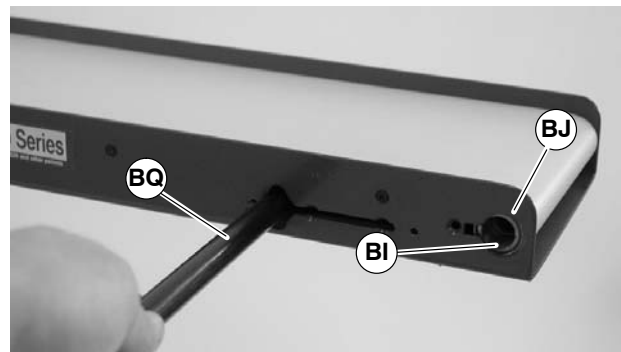

Figure 49

IMPORTANT: Do not hit retaining sleeve (BD of Figure 50) with hammer or any other tool when installing. Inspect frame bore for damage or out of roundness if retaining sleeve does not slide easily into place. Frames with worn holes should be replaced.

Preventive Maintenance and Adjustment

4. Insert retaining sleeve (BD of Figure 50) into pulley. Push in until inside surface of retaining sleeve shoulder (BL) touches outside of frame (BM). Do not push shoulder of retaining sleeve into frame opening.

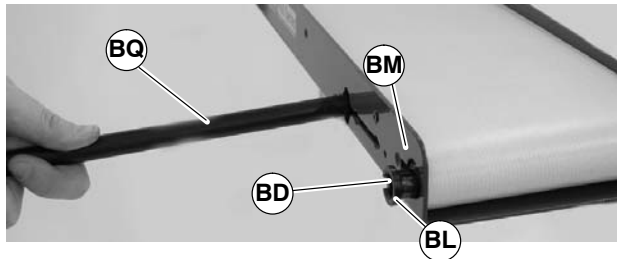

Figure 50

5. Insert pulley installation tool (BQ of Figure 51) into opposite side of conveyor.



Figure 51

6. Using pulley installation tool (BQ) as a lever, align pulley bore with conveyor frame opening. Insert retaining sleeve (BD of Figure 52) into pulley until flush with conveyor frame.

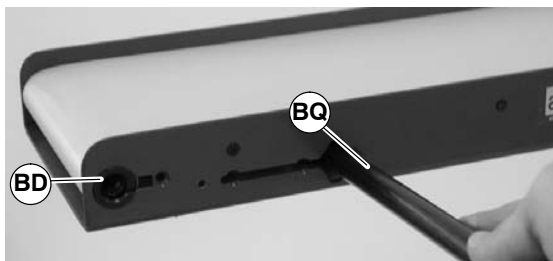

Figure 52

7. Insert pulley installation tool (BQ of Figure 53) into opposite side of conveyor and push retaining sleeve (BD) into pulley until flush with conveyor frame.

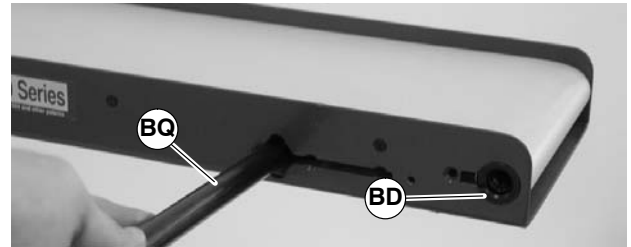

Figure 53

8. Align slot (BO of Figure 54) in retaining sleeve (BD) with slot in conveyor frame (BP).

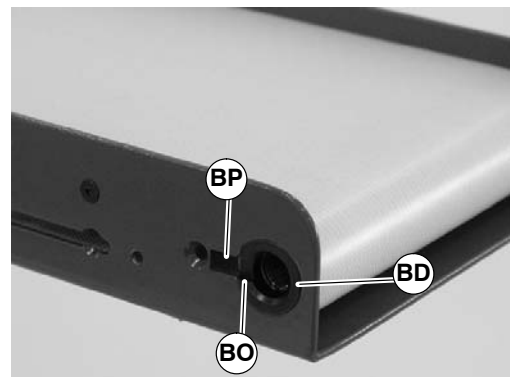

Figure 54

9. Insert retaining sleeve clip (BA of Figure 55) into slot and tighten with screw (AZ).

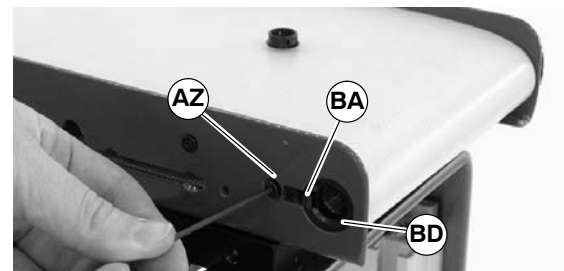

Figure 55

10. Install plastic plug (N of Figure 56).

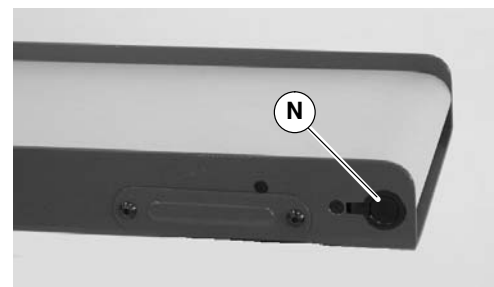

Figure 56

11. Repeat steps 8 through 10 on opposite side of conveyor.

Preventive Maintenance and Adjustment

Return Belt Roller Replacement

Removal

1. Remove conveyor belt. See “Conveyor Belt Removal” section on page 8.
2. Remove screws (BT of Figure 57) on both sides of conveyor.

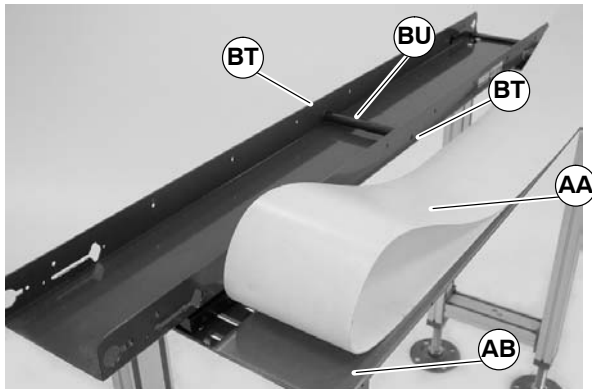

Figure 57

3. Remove return belt roller assembly (BU).

Installation

1. Align holes in ends of return belt roller (BU) with countersink holes (Figure 57).
2. Install screws (BT). Ensure screws are centered in countersink hole.
3. Refer to “Conveyor Belt Replacement – Installation” section.

Pulley Bearing Replacement

IMPORTANT: Once removed, do not re-use bearings.

Bearing Removal

NOTE: Bearings in 1” (25mm) to 2” (51mm) wide conveyors cannot be replaced. See “Service Parts” section pages 18 to 22.

1. Insert bearing removal tool (BV of Figure 58)(25-05, part of tool kit 4500) into the pulley (BW) until shoulder (BX) seats against bottom of bearing (BY).

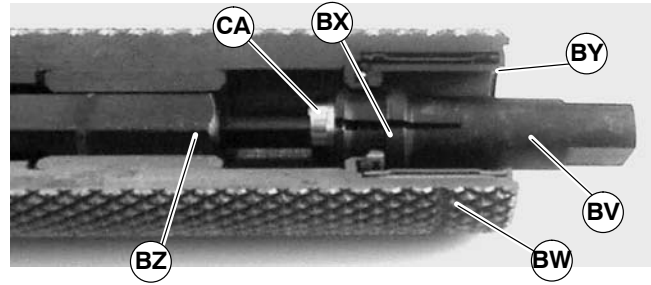

Figure 58

2. While holding bearing removal tool (BV) in position, insert extension tool (BZ)(25-08, part of tool kit 4500) into opposite end of pulley (BW). Rotate bearing removal tool (BV) to engage hex tip of extension tool (BZ) into screw (CA).
3. While maintaining extension tool (BZ of Figure 59) position, use a wrench (CC) to rotate bearing removal tool (BV) to expand flare.

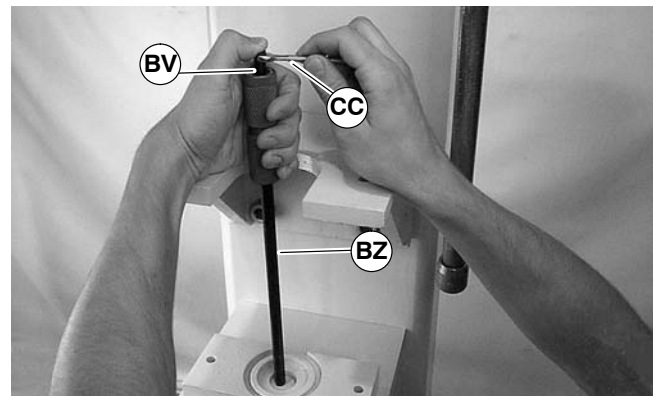

Figure 59

4. Orient bearing anvil/sleeve removal tool (25-09, part of tool kit 4500) (CB of Figure 60) with cavity facing up and place pulley onto tool.

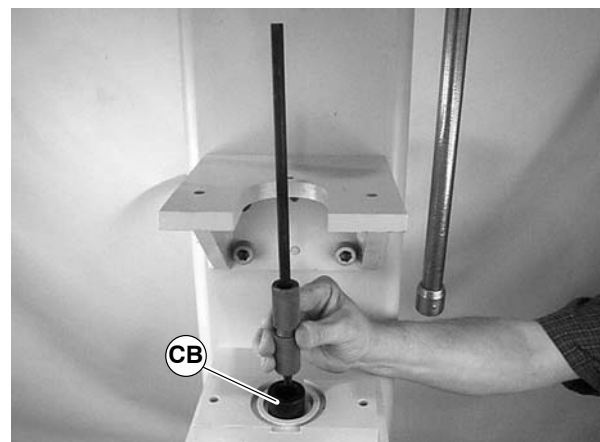

Figure 60

Preventive Maintenance and Adjustment

NOTE: If a severely worn bearing breaks apart during removal, pulley must be replaced.

5. Press bearing (BY) out of pulley.

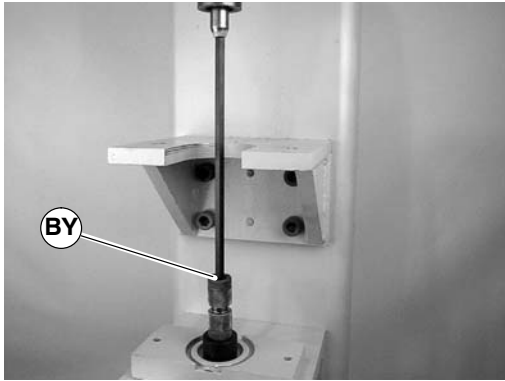

Figure 61

Bearing Installation

1. Orient bearing anvil/sleeve removal tool (CB of Figure 62)(25-09) with cavity facing up and place pulley (BW) onto tool.

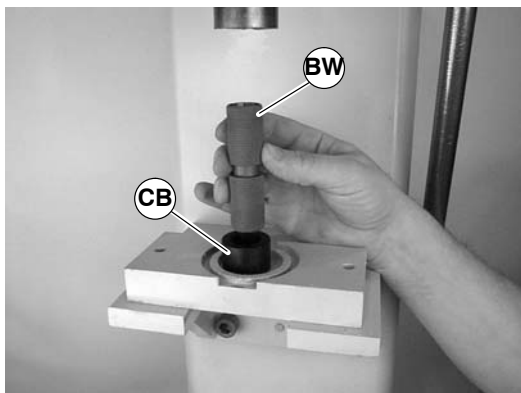

Figure 62

2. Install bearing insertion tool (CC of Figure 63)(25-10, part of tool kit 4500) into arbor press or similar device.

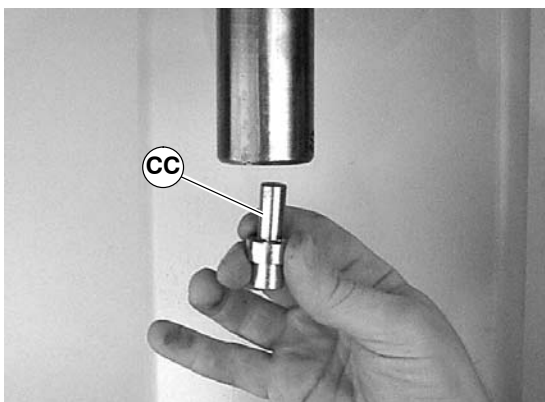

Figure 63

3. Place and hold bearing (BY) onto tool (CC).

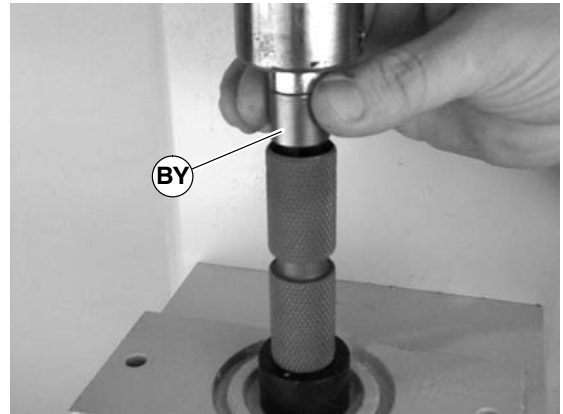

Figure 64

IMPORTANT: Bearing and pulley alignment is critical.

4. Press bearing (BY of Figure 65) into pulley (BW) until seated.

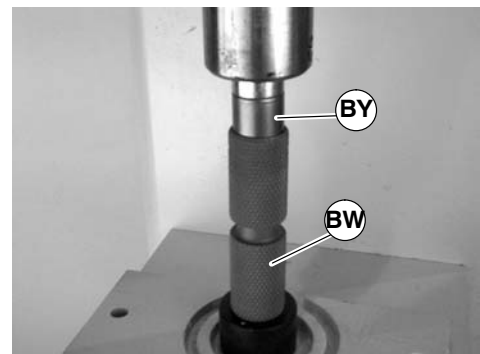



Figure 65

Tension Pin Bearing Replacement

1. Insert 3/16" diameter rod through tension pin tube
2. Lightly tap bearing out opposite end.
3. Carefully press a new bearing (802-021) into the tension pin tube.

Service Parts

NOTE: For replacement parts other than those shown on this section, contact an authorized Dorner Service Center or the factory. Key Service Parts and Kits are identified by the Performance Parts Kits logo . Dorner recommends keeping these parts on hand.

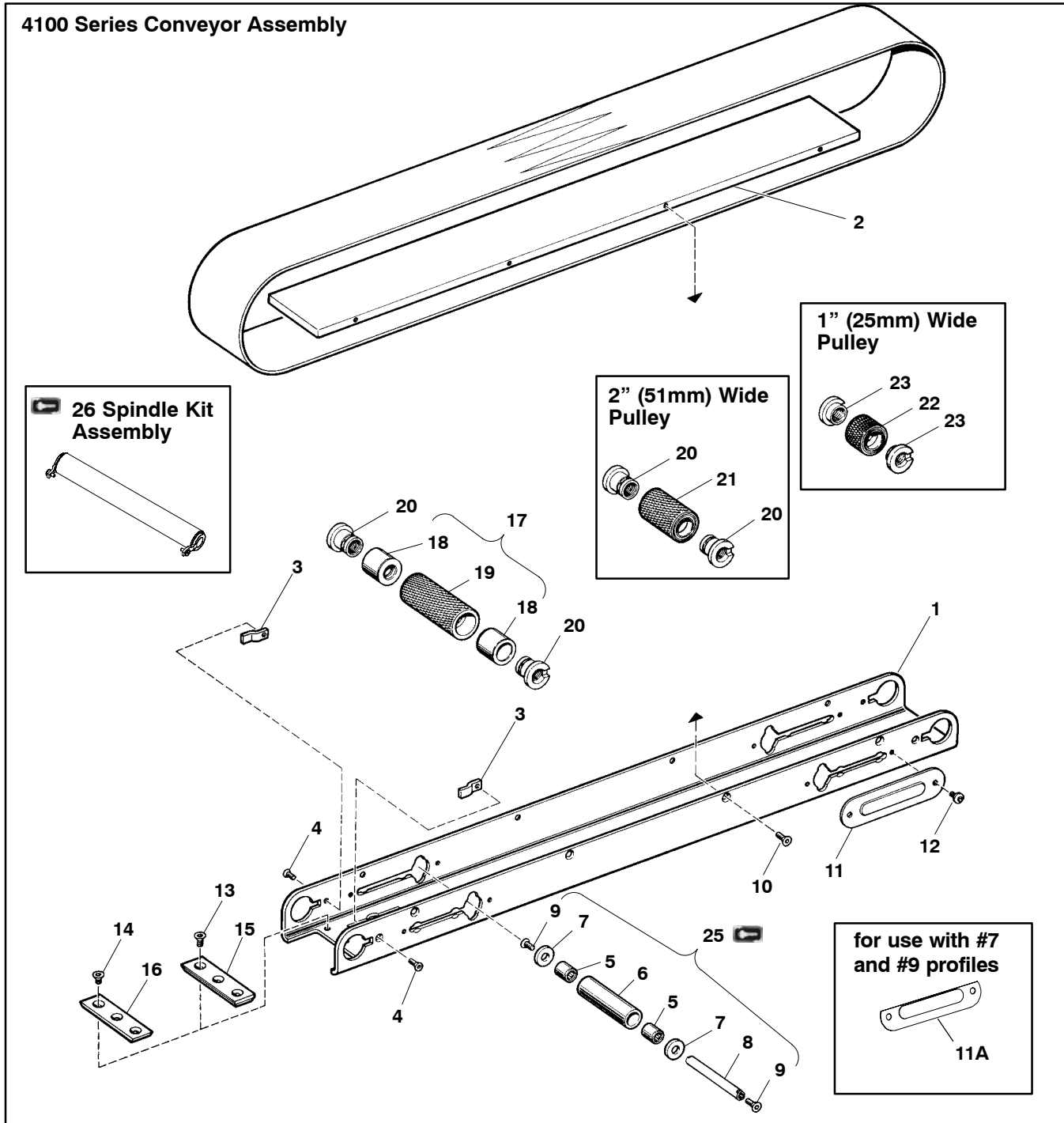

Item	Part Number	Description
1	See Chart Below	Conveyor Frame

2	See Chart Below	Bedplate
3	41-08	Retainer Clip

4	903-037	Flat Head Cap Screw, #6-32 x .38"
5	802-021	Tension Pin Bearing
6	41-W-15	Tension Pin Tube
7	41-18	Thrust Washer
8	41-W-19	Tension Pin Shaft
9	903-059	Flat Head Cap Screw, #8-32 x .38"
10	903-060	Flat Head Screw, #8-32 x .38" (#6 Head)
11	41B22	Tension Pin Cover (Black Paint)
11A	667991B	Tension Pin Cover (Black Paint)
12	901-104	Button Head Cap Screw, #10-32 x .25"
13	903-105	Flat Head Cap Screw, #10-32 x .31"
14	903-102	Flat Head Cap Screw, #10-32 x .19"
15	41-W-50	Bottom Wiper, .22" Thick
16	41-W-51	Bottom Bar, .11" Thick (Used with belt types /04, /06 and all Clipper® Splice Belts)
17	21-W-34	Spindle assembly (Includes Items 18 and 19) for 03 - 12 Width Conveyors
18	21-33	Radial Thrust Bearing
19	21-W-28	Spindle for 03 - 12 Width Conveyors
20	41-35	Spindle Retaining Sleeve for 02 - 12 Width Conveyors
21	21-2-34	Spindle for 02 Width Conveyors
22	41-31	Spindle for 01 Width Conveyors
23	41-32	Spindle Retaining Sleeve for 01 Width Conveyors
24	807-784	Plastic Plug (Not Shown)
25	41-W-21	Tension Pin Assembly (Includes Items 5 through 9)
26	4100-01	Spindle Kit Assembly (Includes Items 3, 4, 22, 23 and 24) for 01 Width Conveyors
	4100-02	Spindle Kit Assembly (Includes Items 3, 4, 20, 21 and 24) for 02 Width Conveyors
	4100-03	Spindle Kit Assembly (Includes Items 3, 4, 17, 20 and 24) for 03 Width Conveyors
	4100-04	Spindle Kit Assembly (Includes Items 3, 4, 17, 20 and 24) for 04 Width Conveyors
	4100-06	Spindle Kit Assembly (Includes Items 3, 4, 17, 20 and 24) for 06 Width Conveyors
	4100-08	Spindle Kit Assembly (Includes Items 3, 4, 17, 20 and 24) for 08 Width Conveyors
4100-12	Spindle Kit Assembly (Includes Items 3, 4, 17, 20 and 24) for 12 Width Conveyors	
W = Conveyor width in inches: 1, 2, 3, 4, 6, 8, 12		

Item 1: Conveyor Frame (Black Paint)	
Length	Part Number
2' (610mm)	41BWW02-E
3' (914mm)	41BWW03-E
4' (1219mm)	41BWW04-E
5' (1524mm)	41BWW05-E
6' (1829mm)	41BWW06-E
WW = Conveyor width reference: 01, 02, 03, 04, 06, 08, 12	
E = Frame style reference: 1, 2, 3, 4, 5	
4100 Series Frame Styles	
<p>STYLE 1 Standard Low Side</p> <p>STYLE 2 Standard High Side</p> <p>STYLE 3 Grooved for Side Wiper</p> <p>STYLE 4 .218" Holes, 6" O.C.</p> <p>STYLE 5 #6-32 Tapped Holes, 3" O.C.</p>	

Item 2: Bedplate	
Length	Part Number
2' (610mm)	41-WW02
3' (914mm)	41-WW03
4' (1219mm)	41-WW04
5' (1524mm)	41-WW05
6' (1829mm)	41-WW06
WW = Conveyor width reference: 01, 02, 03, 04, 06, 08, 12	

Service Parts

Mounting Blocks and Outboard Drive Shaft

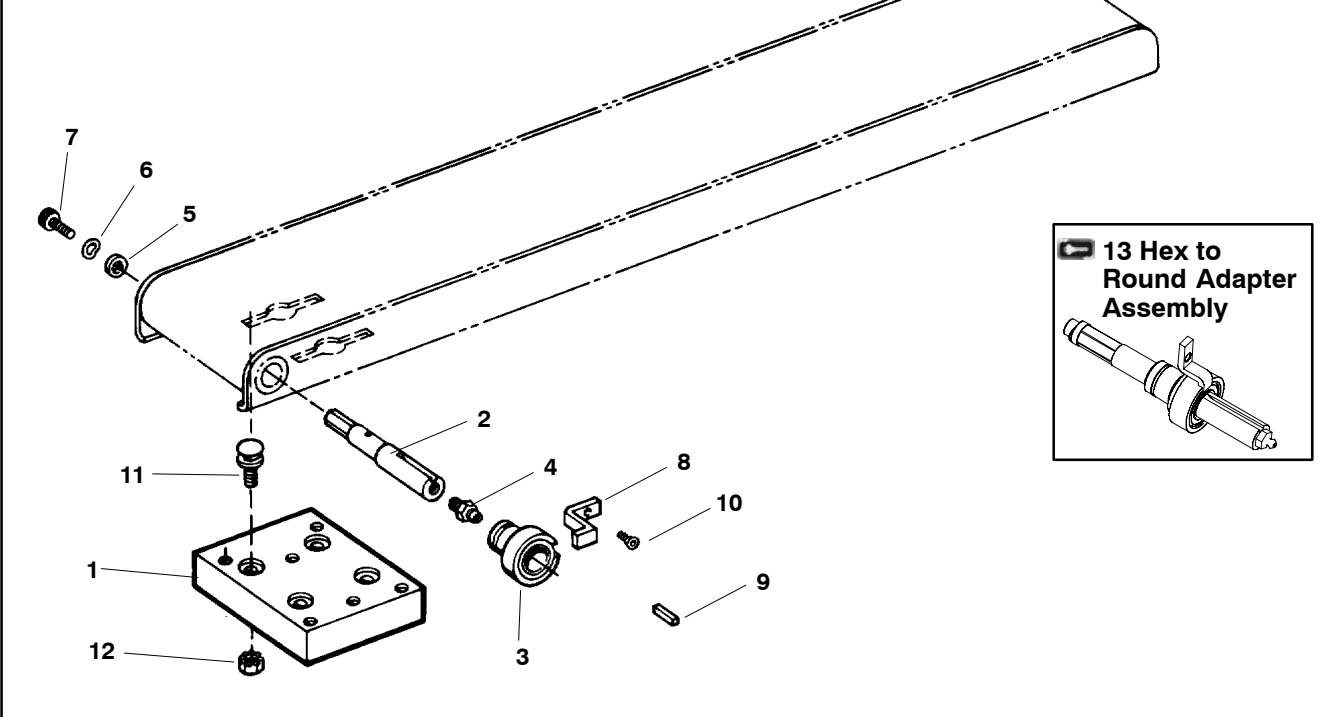

Item	Part Number	Description
1	609486	Mounting Block for 01 Width Conveyors
	609487	Mounting Block for 02 Width Conveyors
	609488	Mounting Block for 03 Width Conveyors
	609479	Mounting Block for 04 Width Conveyors
	609481	Mounting Block for 06 Width Conveyors
	609483	Mounting Block for 08 Width Conveyors
	609485	Mounting Block for 12 Width Conveyors
2	43-38-1-05	.5" Dia. Outboard Drive Shaft for 01 Width Conveyors
	43-38-2-12	.5" Dia. Outboard Drive Shaft for 02 Width Conveyors
	43-38-3-15	.5" Dia. Outboard Drive Shaft for 03 Width Conveyors
	43-38-4-16	.5" Dia. Outboard Drive Shaft for 04 - 12 Width Conveyors
	216202M	12mm Dia. Outboard Drive Shaft for 02 Width Conveyors
	216203M	12mm Dia. Outboard Drive Shaft for 03 Width Conveyors
	216204M	12mm Dia. Outboard Drive Shaft for 04 - 12 Width Conveyors

3	43-38-1-11	Bearing Retaining Sleeve for 01 Width Conveyors
	43-38-2-18	Bearing Retaining Sleeve for 02 - 12 Width Conveyors
4	810-138	Grease Fitting, 1/4-28
	810-292	Grease Fitting, M6
5	43-38-06	Flat Hard Washer
6	807-247	Curved Spring Washer
7	902-902	Socket Head Cap Screw, #10-32 x .63"
8	43-38-08	Retaining Sleeve Retainer Clip
9	912-052	Square Key, 1/8" x 5/8"
	980422M	Square Key, 4mm x 22mm
10	903-037	Flat Head Cap Screw, #6-32 x .38"
11	613602P	Bolt-Flat Washer Assembly
12	910-126	Hex Nut with Lock Washer
13	43-38-01	Hex to Round Adapter Assembly (Includes Items 2, 3 and 8) for 01 Width Conveyors
	43-38-02	Hex to Round Adapter Assembly (Includes Items 2, 3 and 8) for 02 Width Conveyors
	43-38-03	Hex to Round Adapter Assembly (Includes Items 2, 3 and 8) for 03 Width Conveyors
	43-38-04	Hex to Round Adapter Assembly (Includes Items 2, 3 and 8) for 04 - 12 Width Conveyors

-03 Side Wiper

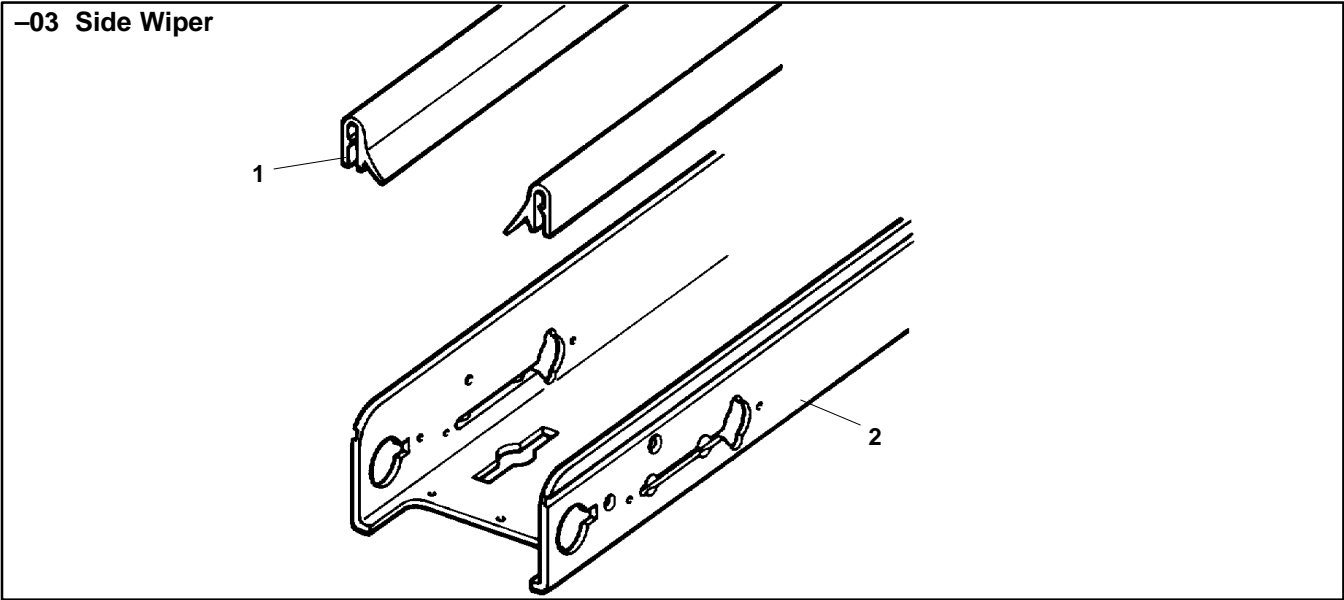

Item	Part Number	Description
1	21-02-03	Side Wiper 2' (610mm) Lg
	21-03-03	Side Wiper 3' (914mm) Lg
	21-04-03	Side Wiper 4' (1219mm) Lg
	21-05-03	Side Wiper 5' (1524mm) Lg
	21-06-03	Side Wiper 6' (1829mm) Lg

2	41BWW02-3	Conveyor Frame 2' (610mm)
	41BWW03-3	Conveyor Frame 3' (914mm)
	41BWW04-3	Conveyor Frame 4' (1219mm)
	41BWW05-3	Conveyor Frame 5' (1524mm)
	41BWW06-3	Conveyor Frame 6' (1829mm)

-07 Low Side to Side Wiper

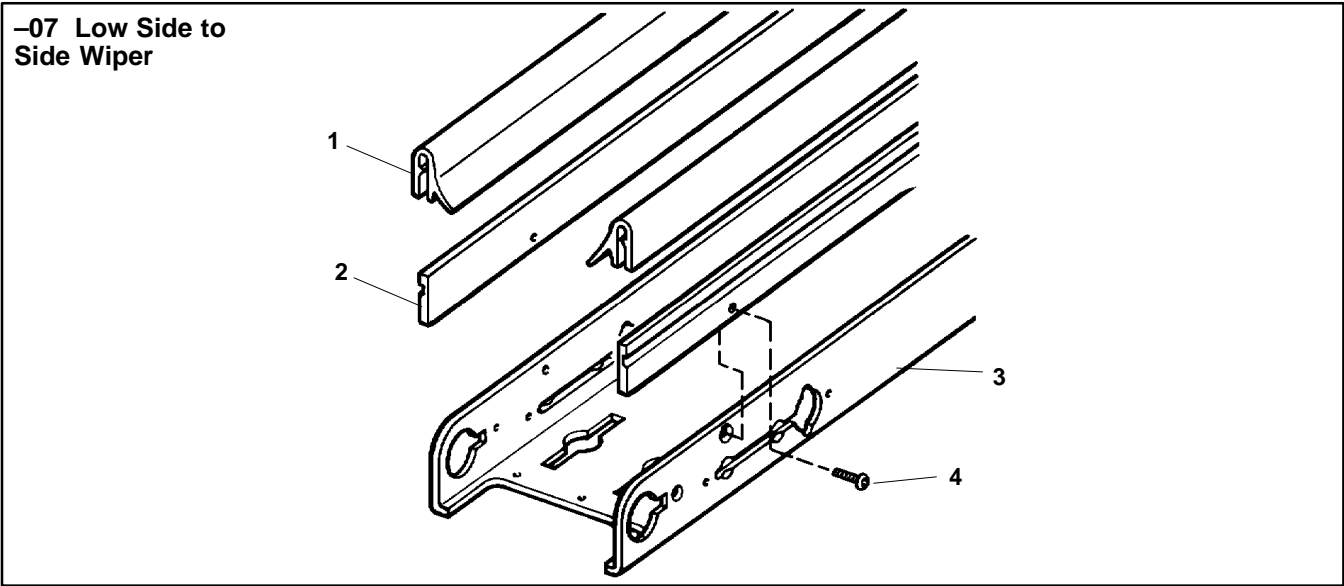

Item	Part Number	Description
1	21-02-03	Side Wiper 2' (610mm) Lg
	21-03-03	Side Wiper 3' (914mm) Lg
	21-04-03	Side Wiper 4' (1219mm) Lg
	21-05-03	Side Wiper 5' (1524mm) Lg
	21-06-03	Side Wiper 6' (1829mm) Lg
2	41-02-07	Low to Side Wiper 2' (610mm)
	41-03-07	Low to Side Wiper 3' (914mm)
	41-04-07	Low to Side Wiper 4' (1219mm)

	41-05-07	Low to Side Wiper 5' (1524mm)
	41-06-07	Low to Side Wiper 6' (1829mm)
3	41BWW02-1	Conveyor Frame 2' (610mm)
	41BWW03-1	Conveyor Frame 3' (914mm)
	41BWW04-1	Conveyor Frame 4' (1219mm)
	41BWW05-1	Conveyor Frame 5' (1524mm)
	41BWW06-1	Conveyor Frame 6' (1829mm)
4	901-062	Button Head Cap Screw #8-32 x .5"

Service Parts

-09 Low to High Side

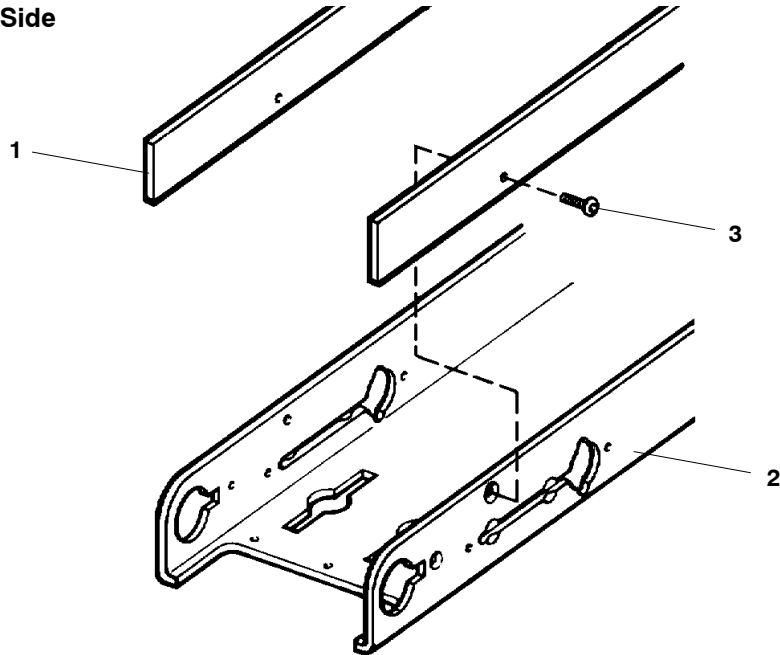

Item	Part Number	Description
1	41-02-09	Low to High Side Wiper 2' (610mm)
	41-03-09	Low to High Side Wiper 3' (914mm)
	41-04-09	Low to High Side Wiper 4' (1219mm)
	41-05-09	Low to High Side Wiper 5' (1524mm)
	41-06-09	Low to High Side Wiper 6' (1829mm)

2	41BWW02-1	Conveyor Frame 2' (610mm)
	41BWW03-1	Conveyor Frame 3' (914mm)
	41BWW04-1	Conveyor Frame 4' (1219mm)
	41BWW05-1	Conveyor Frame 5' (1524mm)
	41BWW06-1	Conveyor Frame 6' (1829mm)
3	901-062	Button Head Cap Screw #8-32 x .5"

Hinged Side Guide

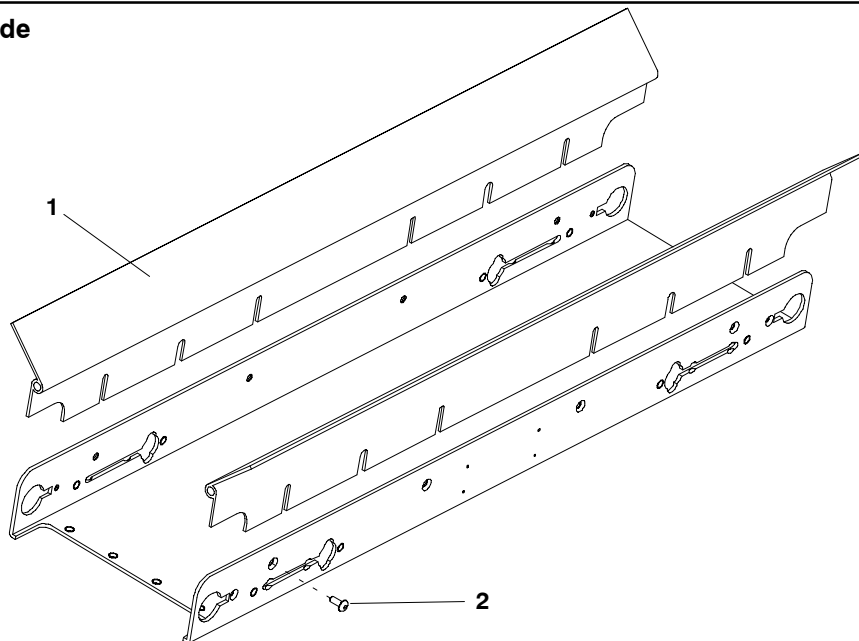

Item	Part Number	Description
1	462532	Hinge Guide 3.5" x 2' (610mm)
	462533	Hinge Guide 3.5" x 3' (914mm)

	462534	Hinge Guide 3.5" x 4' (1219mm)
2	901-059	Button Head Cap Screw #8-32 x .38"

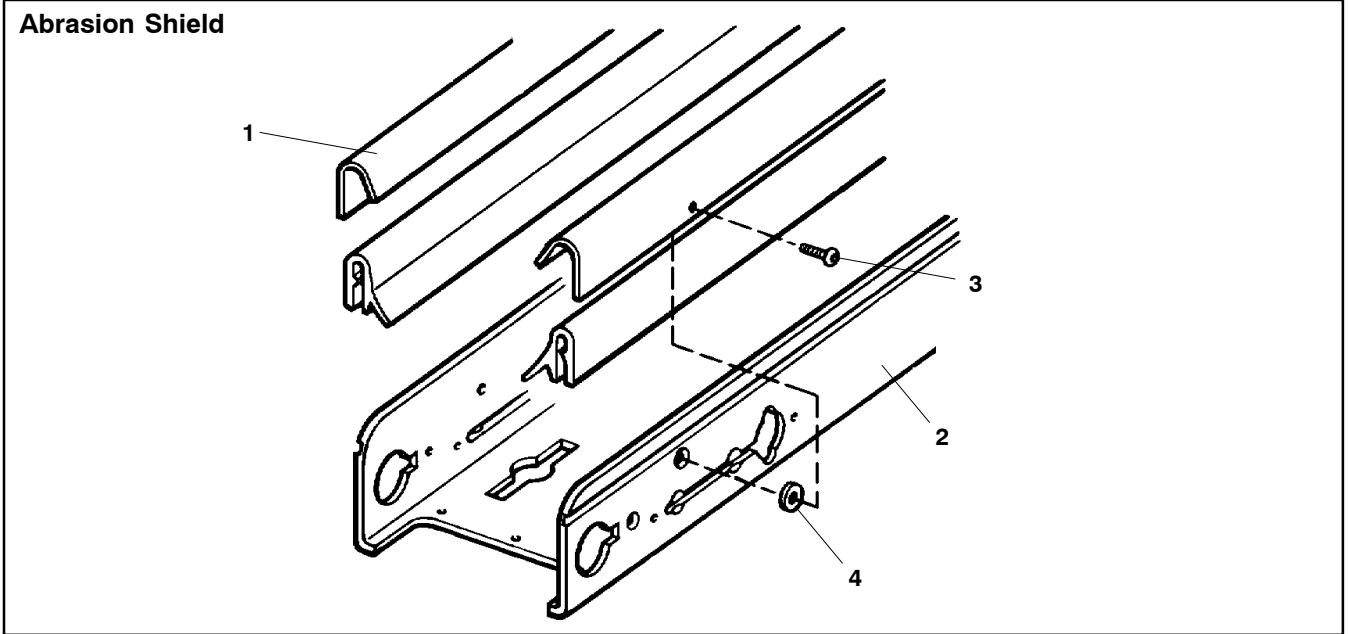

Item	Part Number	Description
1	669307	Abrasion Shield 2' (610mm)
	669308	Abrasion Shield 3' (914mm)
	669309	Abrasion Shield 4' (1219mm)

2	41BWW02-3	Conveyor Frame 2' (610mm)
	41BWW03-3	Conveyor Frame 3' (914mm)
	41BWW04-3	Conveyor Frame 4' (1219mm)
3	901-062	Button Head Cap Screw #8-32 x .5"
4	901-004	Flat Washer #8

Conveyor Belt Part Number Configuration

Flat Belt Conveyor Model Number

4100 WW LL A PP / BB

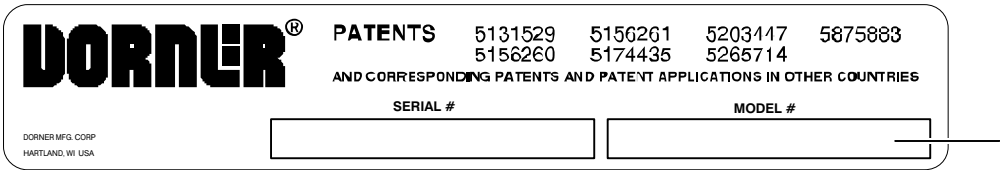

Figure 66

Flat Belt Part Number Configuration

Refer to Dorner patent plate (Figure 66). From the model number, determine conveyor width (“WW”), length (“LL”) and belt type (“BB”). Use data to configure belt part number as indicated below.

41 - WW LL / BB

41 - (Fill In) / _____

Return Policy

No returns will be accepted without prior written factory authorization. When calling for authorization, please have the following information ready for the Dorner Factory representative or your local distributor:

1. Name and address of customer.
2. Item(s) being returned.
3. Reason for return.
4. Customer's original order number used when ordering the item(s).
5. Dorner or distributor invoice number.

A representative will discuss action to be taken on the Returned items and provide a Returned Goods Authorization Number to reference.

There will be a 15% restocking charge on all new items returned for credit where Dorner was not at fault. These will not be accepted after 60 days from original invoice date. The restocking charge covers inspection, cleaning, disassembly, and reissuing to inventory.

If a replacement is needed prior to evaluation of returned item, a purchase order must be issued. Credit (if any) is issued only after return and evaluation is complete.

Dorner has representatives throughout the world. Feel free to contact Dorner for the name of your local representative. Our technical sales and service staff will gladly help with your questions on Dorner products.

For a copy of Dorner's Limited Warranty, contact factory, distributor, service center or visit our website at www.dorner.com.

**For replacement parts, contact an authorized
Dorner Service Center or the factory.**

DORNER[®]

Dorner Mfg. Corp. reserves the right to change or discontinue products without notice. All products and services are covered in accordance with our standard warranty. All rights reserved. ©Dorner Mfg. Corp. 2000

DORNER MFG. CORP.

975 Cottonwood Ave., PO Box 20
Hartland, WI 53029-0020 USA

USA

TEL 1-800-397-8664 (USA)

FAX 1-800-369-2440 (USA)

Internet: www.dorner.com

Outside the USA:

TEL 1-262-367-7600

FAX 1-262-367-5827