

Accessory Assembly Instructions

Profile 13 Guiding

! **WARNING** !

To prevent injury, make sure all electrical power sources have been disconnected before performing any component assembly or adjustments.

Profile 13 guiding may be shipped from the factory in varying stages of assembly. If necessary, assemble the components in the manner shown.

1. Insert each drop-in T-bar (A of Figure 1) into the conveyor frame T-slot (B) by rolling it into position as shown.

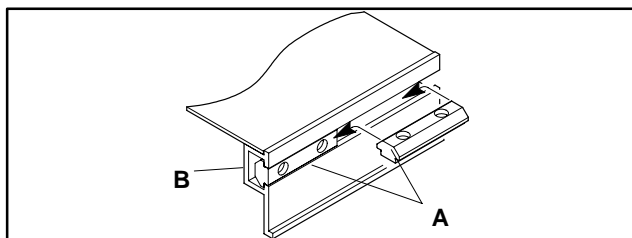

Figure 1: Drop-in T-Bar Installation Detail

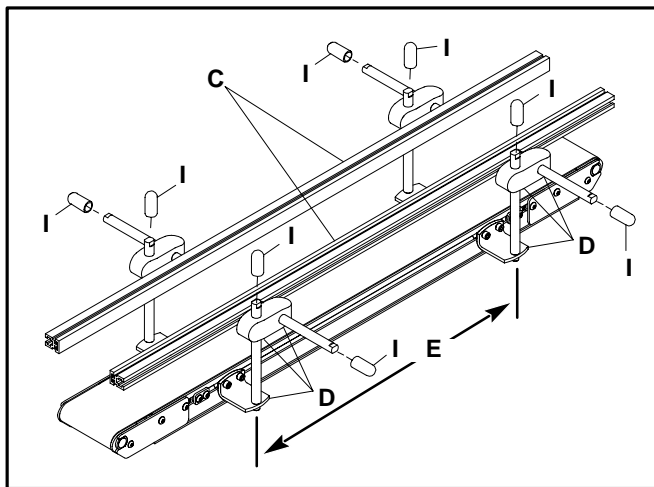
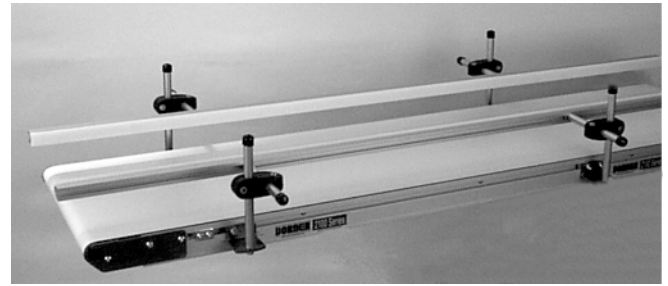

Figure 2

NOTE: Same parts can be installed on 2100 or 3100 Series Belted or Roller Conveyors



NOTE:

For a 3100 Series conveyor, install the Drop-in T-Bar in the upper slot in the same manner.

2. Evenly space the T-bars, on both sides of the conveyor (Figure 2), at distances (E), no greater than 36" (915 mm).
3. After final positioning, be sure to tightly secure all mounting hardware. Install the vinyl caps (I).

Nominal Conveyor Length in ft (mm)	Total Quantity of Support Assemblies (D)
2 (610)	4
3 (915)	4
4 (1220)	4
5 (1525)	4
6 (1830)	6
7 (2135)	6
8 (2440)	6
9 (2745)	8
10 (3050)	8
11 (3355)	8
12 (3660)	8
13 (3965)	10

! **WARNING** !

After installing guiding and before operating conveyor, be sure to eliminate any potential pinch points that may have been created. To prevent injury, keep fingers and hands away from pinch point areas while the conveyor is running.

Accessory Assembly Instructions

Replacement Parts

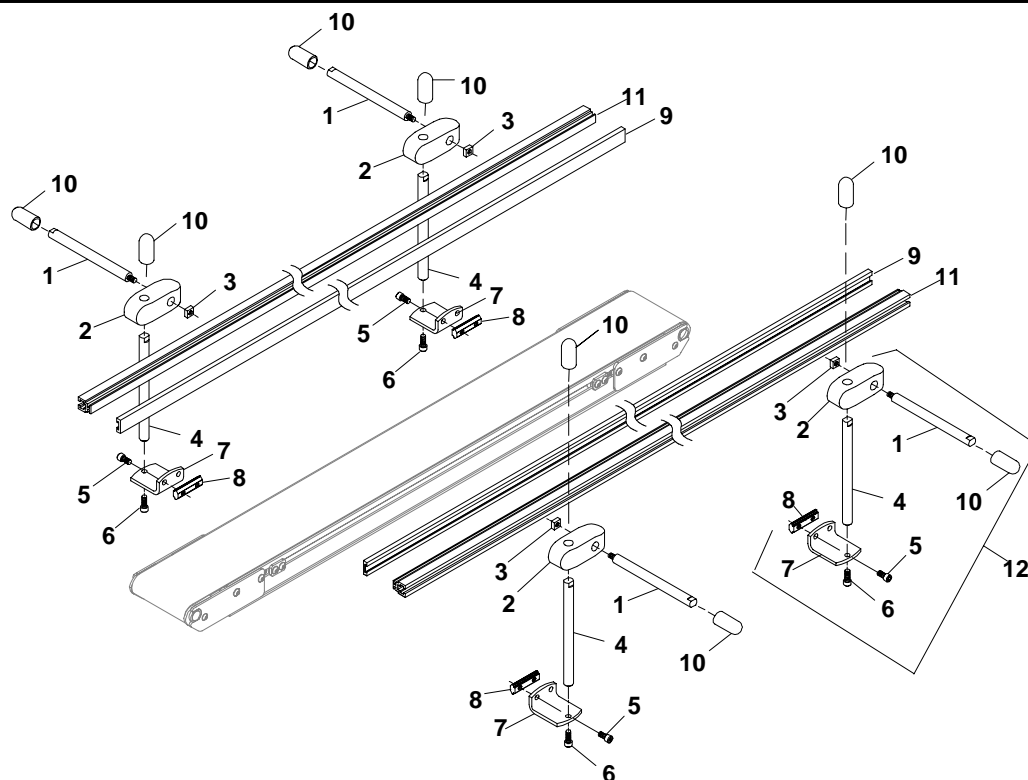

NOTE: Metric parts listed. For SAE parts, other than fasteners, drop the "M" suffix. SAE equivalent fasteners are in shaded areas.

Item	Part No.	Part Description
1	202028M	Guide Horizontal Mounting Shaft
2	807-652	Rod Cross Block
3	674175MP 902-190	Square Nut (Metric) M6-1.0 (SAE) 1/4-20
4	202027M	Guide Vertical Mounting Shaft
5	920612M 902-128	Socket Head Cap Screw (Metric) M6-1.0 x 12 mm (SAE) 1/4-20 x 0.50"
6	920616M 902-130	Socket Head Cap Screw (Metric) M6-1.0 x 16 mm (SAE) 1/4-20 x 0.62"
7	202004M	Conveyor to Shaft Mounting Bracket
8	200830M	Drop-in T-Bar
9	614068P	Profile 13 Guide*
10	807-948	Vinyl Shaft Cap

Item	Part No.	Part Description
11	202983	Guide Mounting Rail 2 ft (610 mm)**
	202984	Guide Mounting Rail 3 ft (915 mm)**
	202985	Guide Mounting Rail 4 ft (1220 mm)**
	202986	Guide Mounting Rail 5 ft (1525 mm)**
	202987	Guide Mounting Rail 6 ft (1830 mm)**
	202988	Guide Mounting Rail 7 ft (2135 mm)**
	202989	Guide Mounting Rail 8 ft (2440 mm)**
	202990	Guide Mounting Rail 9 ft (2745 mm)**
	202991	Guide Mounting Rail 10 ft (3050 mm)**
	202992	Guide Mounting Rail 11 ft (3355 mm)**
	202993	Guide Mounting Rail 12 ft (3660 mm)**
	202994	Guide Mounting Rail 13 ft (3965 mm)**
12	381300M	Guide Mounting Support Assembly

*Ordered in 1 ft (305 mm) increments.

** Nominal Conveyor Length.

DORNER[®]

Dorner Mfg. Corp. reserves the right to change or discontinue products without notice. All products and services are covered in accordance with our standard warranty. All rights reserved. ©Dorner Mfg. Corp. 1998

DORNER MFG. CORP.

580 Industrial Drive, PO Box 20
Hartland, WI 53029-0020 USA
USA

TEL 1-800-397-8664 (USA)
FAX 1-800-369-2440 (USA)

Outside the USA:
TEL 1-414-367-7600, FAX
1-414-367-5927

DORNER

Arnold-Sommerfeld-Ring 2
D-52499 Baesweiler

Germany

TEL (02401) 80 52 90
FAX (02401) 80 52 93