

### 2100, 2200, 4100, 6200 and MPB Series Bottom Mount Drive Package for Standard Load Parallel Shaft 60 Hz Gearmotors



## Table of Contents

Warnings – General Safety	2	Service Parts	14
Introduction	2	2100, 2200, 4100, 6200 Series and MPB Series	
Product Description	3	Flat Belt Bottom Mount Drive Package	14
Specifications	3	MPB Series Cleated Belt Bottom Mount	
Gearmotors	3	Drive Package	15
Belt Speed Tables	4	4100 Series Adapter Package	16
Installation	8	Gear Motor	16
Required Tools	8	Return Policy	18
Mounting	8		
Preventative Maintenance & Adjustment	11		
Required Tools	11		
Timing Belt Tensioning	11		
Timing Belt Replacement	11		
Drive or Driven Pulley Replacement	12		
Gear Motor Replacement	12		

# Warnings – General Safety

	<b>WARNING</b>	
<p>The safety alert symbol, black triangle with white exclamation, is used to alert you to potential personal injury hazards.</p>		

		<b>DANGER</b>
<p>Climbing, sitting, walking or riding on conveyor will cause severe injury. <b>KEEP OFF CONVEYORS.</b></p>		

		<b>DANGER</b>
<p>Do NOT OPERATE CONVEYORS IN AN EXPLOSIVE ENVIRONMENT.</p>		

		<b>WARNING</b>
<p>Exposed moving parts can cause severe injury. <b>LOCK OUT POWER</b> before removing guards or performing maintenance.</p>		

		<b>WARNING</b>
<p>Gearmotors may be HOT. <b>DO NOT TOUCH</b> Gearmotors.</p>		

		<b>WARNING</b>
<p>Exposed moving parts can cause severe injury. <b>REPLACE ALL GUARDS BEFORE RUNNING CONVEYOR.</b></p>		

		<b>WARNING</b>
<p>Dorner cannot control the physical installation and application of conveyors. Taking protective measures is the responsibility of the user.</p> <p>When conveyors are used in conjunction with other equipment or as part of a multiple conveyor system, <b>CHECK FOR POTENTIAL PINCH POINTS</b> and other mechanical hazards before system start-up.</p>		

		<b>WARNING</b>
<p>MPB Series Conveyors are not reversible. Reversing creates pinch points which can cause severe injury. <b>DO NOT REVERSE MPB SERIES CONVEYORS.</b></p>		

## Introduction

**IMPORTANT: Some illustrations may show guards removed. Do NOT operate equipment without guards.**

Upon receipt of shipment:

- Compare shipment with packing slip. Contact factory regarding discrepancies.
- Inspect packages for shipping damage. Contact carrier regarding damage.
- Accessories may be shipped loose. See accessory instructions for installation.

Dorner 2100 Series conveyors are covered by the following patent numbers: 5131529, 5174435, and corresponding patents and patent applications in other countries.

Dorner 2200 and MPB Series conveyors are covered by patent number 5174435 and corresponding patents and patent in other countries.

Dorner 2200 and MPB Series conveyors are covered by patent number 5174435 and corresponding patents and patent applications in other countries.

Dorner 4100 Series conveyors are covered by patent number 3923148 and corresponding patents and patent applications in other countries.

Dorner 6200 Series conveyors are covered by patent numbers: 6685009, 5174435, 6109427 and corresponding patents and patent applications in other countries.

Dorner's Limited Warranty applies.

Dorner reserves the right to make changes at any time without notice or obligation.

Dorner has convenient, pre-configured kits of Key Service Parts for all conveyor products. These time saving kits are easy to order, designed for fast installation, and guarantee you will have what you need when you need it. Key Parts and Kits are marked in the Service Parts section of this manual with the Performance Parts Kits logo

# Product Description

Refer to Figure 1 for typical components.

Typical Components	
A	Conveyor
B	Mounting Bracket
C	Gearmotor
D	Timing Belt Tensioner
E	Cover
F	Timing Belt
G	Drive Pulley
H	Driven Pulley

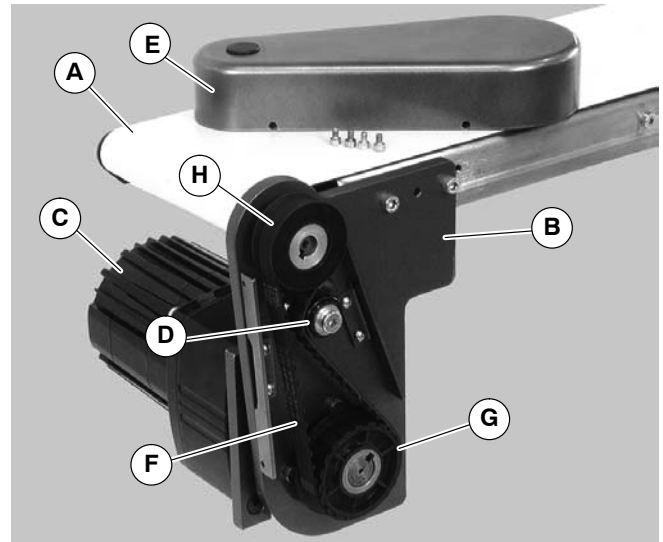

Figure 1

# Specifications

## Gearmotor Mounting Package Models:

Example:

2 M B P S W W A - 32 32

- 2 = 2100 Series Conveyor
- 22 = 2200 Series Conveyor
- 4 = 4100 Series Conveyor
- 6 = 6200 Series Conveyor
- 2P = MPB Series Conveyor
- M = Mount Style = Bottom Mount
- B = Mount Position = A, B, C or D (see detail to the right)
- P = Output Shaft Type = Parallel Shaft
- S = Gearmotor Type = Standard Load, Industrial
- W = Belt Type (- = flat belt, A through J = cleated belt)
- W = Conveyor Width Reference\*
- A = Drive Pulley (see Table 2 & 3)
- 32 = Driven Pulley (see Table 2 & 3)

\* See "Ordering and Specifications" Catalog for details.

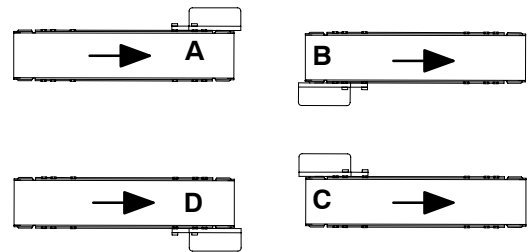

Table 1: Gearmotor Specifications

	Single Phase	Three Phase	DC Variable Speed
Output Power	0.17 hp (0.13 kw)		0.25 hp (0.19 kw)
Input Voltage	115 Volts A.C.	230 Volts A.C.	130 Volts D.C.
Input Frequency	60 Hz		N/A
Input Current	1.9 Amperes	1.2 Amperes	1.8 Amperes
Motor RPM	1725		2500
Gearmotor Ratios	5:1, 10:1, 20:1, 30:1, 60:1, 180:1		
Motor Type	Totally enclosed, Fan-cooled		Totally enclosed, Non-ventilated

# Specifications

**Table 2: Belt Speeds for Standard Load Fixed Speed Parallel Shaft 60 Hz Gearmotors on 2100, 2200 Gang Drive, 4100 and 6200 Series Conveyors**

Belt Speed		Gearmotors					Drive Pulley	Driven Pulley
Ft/min	M/min	Part Number	Gear Ratio	RPM	In-lb	N-m		
2	0.6	62M180PS4(vp)F(n)	180:1	10	341	38.5	22	32
3	0.9	62M180PS4(vp)F(n)	180:1	10	341	38.5	32	32
4	1.2	62M180PS4(vp)F(n)	180:1	10	341	38.5	48	32
6	1.7	62M060PS4(vp)F(n)	60:1	29	270	30.5	22	32
8	2.4	62M060PS4(vp)F(n)	60:1	29	270	30.5	32	32
12	3.7	62M060PS4(vp)F(n)	60:1	29	270	30.5	48	32
16	4.9	62M030PS4(vp)F(n)	30:1	58	135	15.3	32	32
25	7.6	62M020PS4(vp)F(n)	20:1	86	90	10.2	32	32
37	11.3	62M020PS4(vp)F(n)	20:1	86	90	10.2	48	32
49	14.9	62M010PS4(vp)F(n)	10:1	173	45	5.1	32	32
74	22.6	62M010PS4(vp)F(n)	10:1	173	45	5.1	48	32
99	30.2	62M005PS4(vp)F(n)	5:1	345	25	2.8	32	32
148	45.1	62M005PS4(vp)F(n)	5:1	345	25	2.8	48	32
169	51.5	62M005PS4(vp)F(n)	5:1	345	25	2.8	48	28
197	60.0	62M005PS4(vp)F(n)	5:1	345	25	2.8	44	22
215	65.5	62M005PS4(vp)F(n)	5:1	345	25	2.8	48	22
249	75.9	62M005PS4(vp)F(n)	5:1	345	25	2.8	48	19

(vp) = voltage and phase  
 11 = 115 V, 1-phase  
 23 = 230V, 3-phase

(n) = reversing capability  
 N = no reversing switch  
 R = with reversing switch  
 (115V, 1 phase only)

**Table 3: Belt Speeds for Standard Load Fixed Speed Parallel Shaft 60 Hz Gearmotors on 2200 Series Conveyors (Excluding Gang Drive)**

Belt Speed		Gearmotors *					Drive Pulley	Driven Pulley
Ft/min	M/min	Part Number	Gear Ratio	RPM	In-lb	N-m		
3	0.9	62M180PS4(vp)F(n)	180:1	10	341	38.5	28	28
5	1.5	62M180PS4(vp)F(n)	180:1	10	341	38.5	44	22
6	1.7	62M060PS4(vp)F(n)	60:1	29	270	30.5	19	32
10	3.0	62M060PS4(vp)F(n)	60:1	29	270	30.5	28	28
16	4.9	62M060PS4(vp)F(n)	60:1	29	270	30.5	44	28
30	9.1	62M020PS4(vp)F(n)	20:1	86	90	10.2	28	28
48	14.6	62M020PS4(vp)F(n)	20:1	86	90	10.2	44	28
61	18.6	62M010PS4(vp)F(n)	10:1	173	45	5.1	28	28
95	29.0	62M010PS4(vp)F(n)	10:1	173	45	5.1	44	28
104	31.7	62M010PS4(vp)F(n)	10:1	173	45	5.1	48	28
121	36.9	62M005PS4(vp)F(n)	5:1	345	25	2.8	28	28
138	42.1	62M005PS4(vp)F(n)	5:1	345	25	2.8	32	28
176	53.6	62M005PS4(vp)F(n)	5:1	345	25	2.8	32	22
208	63.4	62M005PS4(vp)F(n)	5:1	345	25	2.8	48	28
242	73.8	62M005PS4(vp)F(n)	5:1	345	25	2.8	44	22
264	80.5	62M005PS4(vp)F(n)	5:1	345	25	2.8	48	22

(vp) = voltage and phase  
 11 = 115 V, 1-phase  
 23 = 230V, 3-phase

(n) = reversing capability  
 N = no reversing switch  
 R = with reversing switch  
 (115V, 1 phase only)

# Specifications

**Table 4: Belt Speeds for Standard Load Fixed Speed Parallel Shaft 60 Hz Gearmotors on MPD Series Conveyors**

Belt Speed		Gearmotors					Drive Pulley	Driven Pulley
Ft/min	M/min	Part Number	Gear Ratio	RPM	In-lb	N-m		
4.5	1.4	62M180PS4(vp)F(n)	180:1	10	341	38.5	22	32
6	1.7	62M060PS4(vp)F(n)	60:1	29	270	30.5	19	32
6.5	2	62M180PS4(vp)F(n)	180:1	10	341	38.5	28	28
13	4.0	62M060PS4(vp)F(n)	60:1	29	270	30.5	22	32
20	6.0	62M060PS4(vp)F(n)	60:1	29	270	30.5	28	28
39	11.9	62M030PS4(vp)F(n)	30:1	58	135	15.3	28	28
59	17.9	62M020PS4(vp)F(n)	20:1	86	90	10.2	28	28

(vp) = voltage and phase  
 11 = 115 V, 1-phase  
 23 = 230V, 3-phase

(n) = reversing capability  
 N = no reversing switch  
 R = with reversing switch  
 (115V, 1 phase only)

**Table 5: Belt Speeds for Standard Load Variable Speed Parallel Shaft VFD Gearmotors on 2100, 4100 and 6200 Series Conveyors**

Belt Speed		Gearmotors					Drive Pulley	Driven Pulley
Ft/min	M/min	Part Number	Gear Ratio	RPM*	In-lb*	N-m*		
.6-5.6	.2-1.7	62M060PS423EN	60:1	29	270	30.5	22	32
.8-8.2	.3-2.5	62M060PS423EN	60:1	29	270	30.5	32	32
2.5-25	.8-7.5	62M020PS423EN	20:1	86	167	18.9	32	32
4.9-49	1.5-15	62M010PS423EN	10:1	173	115	13	32	32
9.9-99	3-30	62M005PS423EN	5:1	345	58	6.5	32	32
14-148	4.5-45	62M005PS423EN	5:1	345	58	6.5	48	32
19-197	6-60	62M005PS423EN	5:1	345	58	6.5	44	22
24-249	7.6-76	62M005PS423EN	5:1	345	58	6.5	48	19

\* At 60 Hz

**Table 6: Belt Speeds for Standard Load Variable Speed Parallel Shaft VFD Gearmotors on 2200 Series Conveyors (Excluding Gang Drive)**

Belt Speed		Gearmotors *					Drive Pulley	Driven Pulley
Ft/min	M/min	Part Number	Gear Ratio	RPM*	In-lb*	N-m*		
.6-6	.2-1.8	62M060PS423EN	60:1	29	270	30.5	19	32
1-10	.3-3.1	62M060PS423EN	60:1	29	270	30.5	28	28
3-30	.9-9.2	62M020PS423EN	20:1	86	167	18.9	28	28
6-60	1.8-18	62M010PS423EN	10:1	173	115	13	28	28
10-104	3.2-32	62M010PS423EN	10:1	173	115	13	48	28
12-121	3.7-37	62M005PS423EN	5:1	345	58	6.5	28	28
26-264	8.1-81	62M005PS423EN	5:1	345	58	6.5	48	22

\* At 60 Hz

# Specifications

**Table 7: Belt Speeds for Standard Load Variable Speed Parallel Shaft VFD Gearmotors on MPD Series Conveyors**

Belt Speed		Gearmotors					Drive Pulley	Driven Pulley
Ft/min	M/min	Part Number	Gear Ratio	RPM*	In-lb*	N-m*		
1.3-13.4	.4-4.1	62M060PS423DEN	60:1	29	270	30.5	22	32
2-19	.9-5.9	62M060PS423DEN	60:1	29	270	30.5	28	28
5.9-59	1.8-18	62M020PS423DEN	20:1	86	167	18.9	28	28
11-117	3.6-36	62M010PS423DEN	10:1	173	115	13	28	28
17-175	5.4-54	62M010PS423DEN	10:1	173	115	13	48	32
23-234	7.1-71	62M005PS423DEN	5:1	345	58	6.5	28	28

\* At 60 Hz

**Table 8: Belt Speeds for Standard Load Variable Speed Parallel Shaft DC Gearmotors on 2100, 4100 and 6200 Series Conveyors**

Belt Speed		Gearmotors					Drive Pulley	Driven Pulley
Ft/min	M/min	Part Number	Gear Ratio	RPM	In-lb	N-m		
.3-2.7	.1-.8	62M180PSD3DEN	180:1	14	341	38.5	22	32
.5-4	.1-1.2	62M180PSD3DEN	180:1	14	341	38.5	32	32
1.0-8.2	.3-2.5	62M060PSD3DEN	60:1	42	270	30.5	22	32
1.4-12	.4-3.6	62M060PSD3DEN	60:1	42	270	30.5	32	32
2.9-24	.9-7.3	62M030PSD3DEN	30:1	83	135	15.3	32	32
4.3-36	1.3-11	62M020PSD3DEN	20:1	125	90	10.2	32	32
9-71	2.6-22	62M010PSD3DEN	10:1	250	72	8.1	32	32
17-143	5.2-43	62M005PSD3DEN	5:1	500	25	2.8	32	32
26-214	7.8-65	62M005PSD3DEN	5:1	500	25	2.8	48	32
29-245	9.0-75	62M005PSD3DEN	5:1	500	25	2.8	48	28

**Table 9: Belt Speeds for Standard Load Variable Speed Parallel Shaft DC Gearmotors on 2200 Series Conveyors (Excluding Gang Drive)**

Belt Speed		Gearmotors					Drive Pulley	Driven Pulley
Ft/min	M/min	Part Number	Gear Ratio	RPM	In-lb	N-m		
.4-3.4	.1-1.0	62M180PSD3DEN	180:1	14	341	38.5	22	32
.6-5	.2-1.5	62M180PSD3DEN	180:1	14	341	38.5	28	28
1.8-14	.5-4.5	62M060PSD3DEN	60:1	42	270	30.5	28	28
2.8-23	.8-7	62M060PSD3DEN	60:1	42	270	30.5	44	28
3.5-29	1.1-9	62M030PSD3DEN	30:1	83	135	15.3	28	28
5.3-44	1.6-13	62M020PSD3DEN	20:1	125	90	10.2	28	28
10-88	3.2-27	62M010PSD3DEN	10:1	250	72	8.1	28	28
17-138	5-42	62M005PSD3DEN	5:1	500	25	2.8	44	28
21-176	6.4-54	62M005PSD3DEN	5:1	500	25	2.8	28	28
33-276	10-84	62M005PSD3DEN	5:1	500	25	2.8	44	28

# Specifications

**Table 10: Belt Speeds for Standard Load Variable Speed Parallel Shaft DC Gearmotors on MPB Series Conveyors**

Belt Speed		Gearmotors					Drive Pulley	Driven Pulley
Ft/min	M/min	Part Number	Gear Ratio	RPM	In-lb	N-m		
1.1-9	.3-2.9	62M180PSD3DEN	180:1	14	341	38.5	28	28
2.3-19	.7-5.9	62M060PSD3DEN	60:1	42	270	30.5	22	32
3.4-28	1-8.6	62M060PSD3DEN	60:1	42	270	30.5	28	28
5.3-44	1.6-13	62M060PSD3DEN	60:1	42	270	30.5	44	28
6.8-57	2.1-17	62M030PSD3DEN	30:1	83	135	15.3	28	28
10-85	3-26	62M020PSD3DEN	20:1	125	90	10.2	28	28
15-127	4.7-39	62M020PSD3DEN	20:1	125	90	10.2	48	32
20-170	6-52	62M010PSD3DEN	10:1	250	72	8.1	28	28
31-255	9-77	62M010PSD3DEN	10:1	250	72	8.1	48	32

\* = Cleated and Sidewall Cleated belts operate at a maximum of 150 Ft/min (45.7 m/min)

**NOTE: For belt speed other than those listed, contact factory for details.**

# Installation

## Required Tools

- Hex key wrenches:  
2 mm, 2.5 mm, 3 mm, 5 mm
- Torque wrench

## Mounting

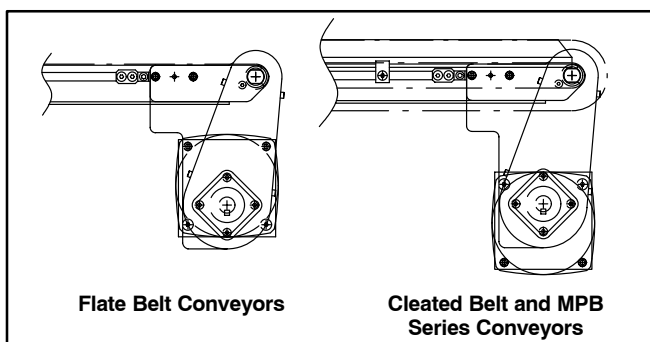
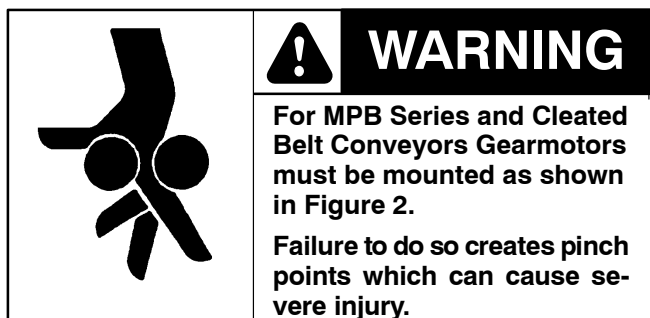
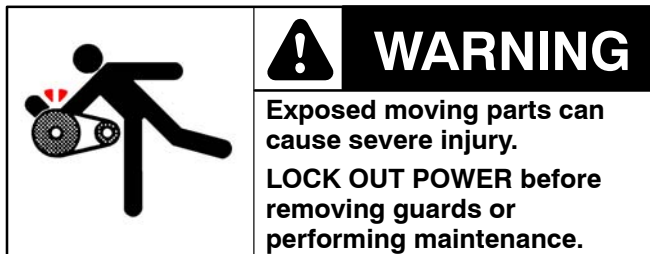

Figure 2

**NOTE:** Gearmotor position on Flat Belt conveyor shown at left (Figure 2). Gearmotor position on Cleated Belt or MPB Series conveyor shown at right (Figure 2).

## 1. Typical components (Figure 3)

Installation Component List	
I	Bottom Mount Assembly
J	Drive Pulley
K	Cover
L	M4 Socket Head Screws (4x)
M	Driven Pulley
N	Key
O	M6 Socket Head Screws (2x)
P	Timing Belt

**NOTE:** Flat belt mounting package shown below (Figure 3), cleated belt mounting package similar.

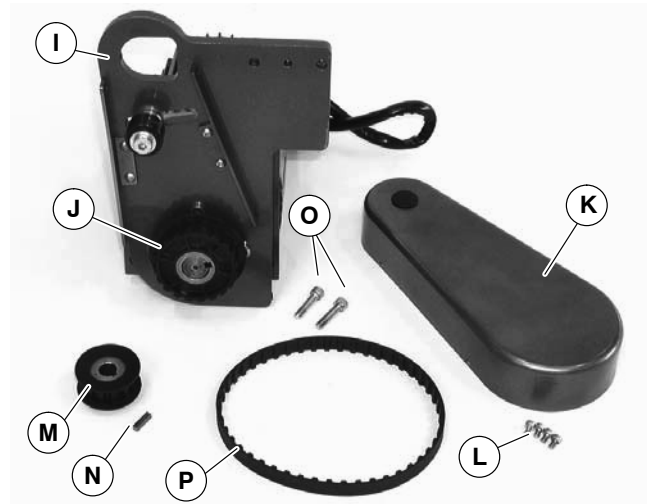

Figure 3



2. For your reference, the following figures show the attachment area of complete mounting packages for the various conveyor series.

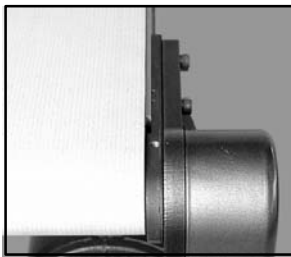

Figure 4 - 2200 Series

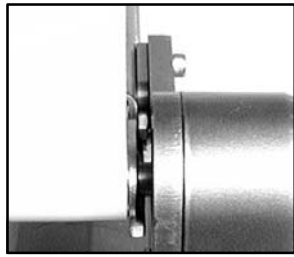

Figure 5 - 6200 Series

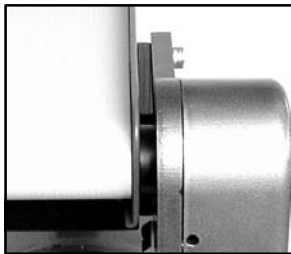

Figure 6 - 4100 Series

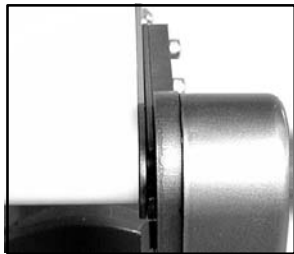

Figure 7 - 2100 Series

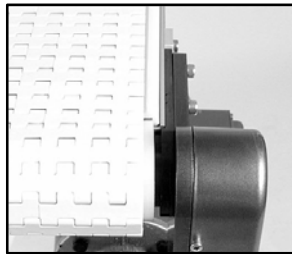

Figure 8 - MPB Series

**NOTE: 6200 conveyor shown, other Series similar.**

3. Locate drive output shaft (R of Figure 9) and remove two (2) screws (S).

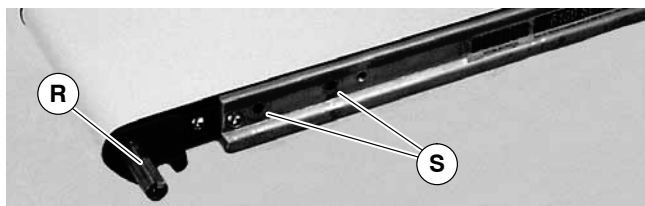

Figure 9

4. Attach mounting assembly (I of Figure 10) with screws (O). Tighten to 80 in-lb (9 Nm).

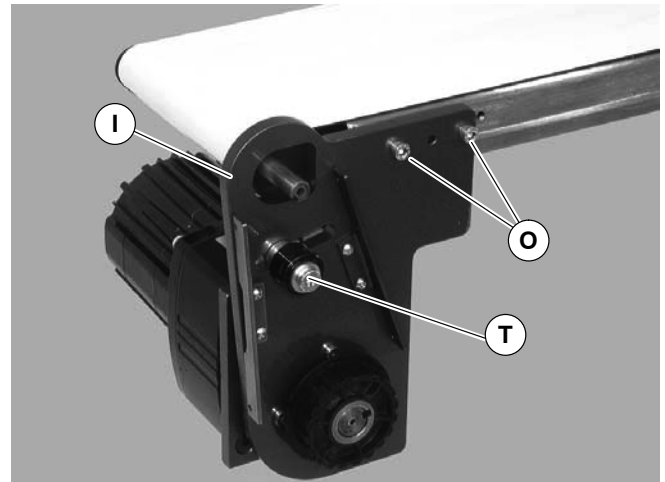

Figure 10

		<h2>WARNING</h2>

5. Install key (N of Figure 11).

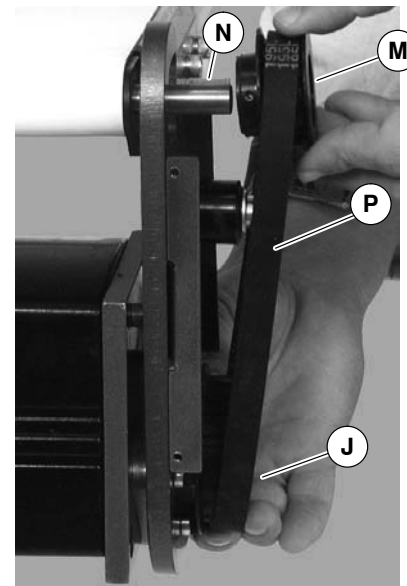

Figure 11

6. Wrap timing belt (P) around driven pulley (M) and drive pulley (J). Install driven pulley (M) onto conveyor shaft.

# Installation

7. Remove cam bearing and spacer (T of Figure 10). Place the cam bearing and spacer (T of Figure 12) next to the driven pulley (M). Ensure the flanges of the driven pulley are aligned with the cam bearing. Tighten driven pulley set screws (U). This will allow for proper belt alignment while conveyor is in use. Replace cam bearing and spacer (T).

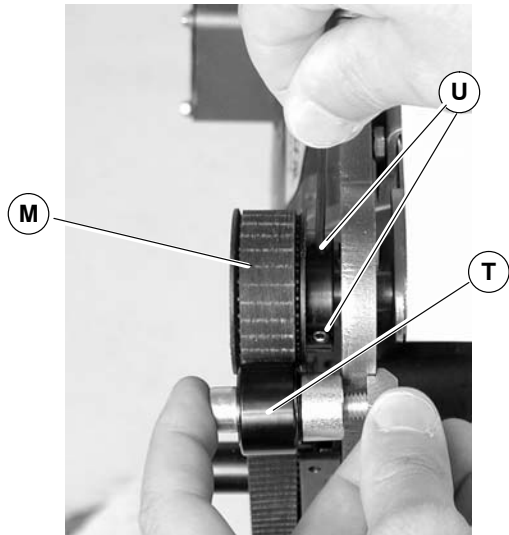

Figure 12

8. Depending on direction of conveyor belt travel (1 or 2 of Figure 13), position belt tensioner (V) as shown. Tension belt to obtain 0.125" (3 mm) deflection for 1.0 lb (456 grams) of force at belt mid-point (W). Tighten tensioner screw to 103 in-lb (12 Nm).

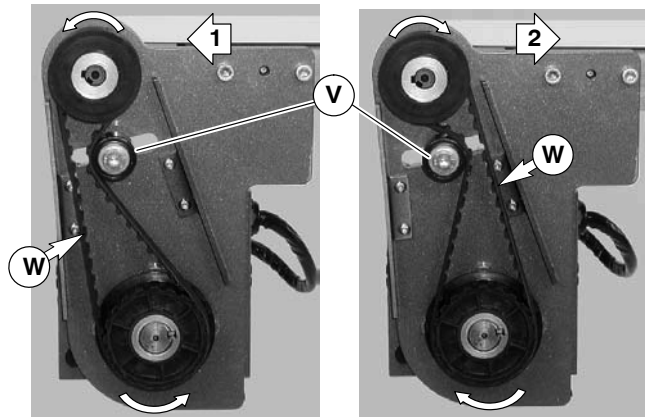

Figure 13

9. Install cover (K of Figure 14) with four (4) screws (L). Tighten to 35 in-lb (4 Nm).

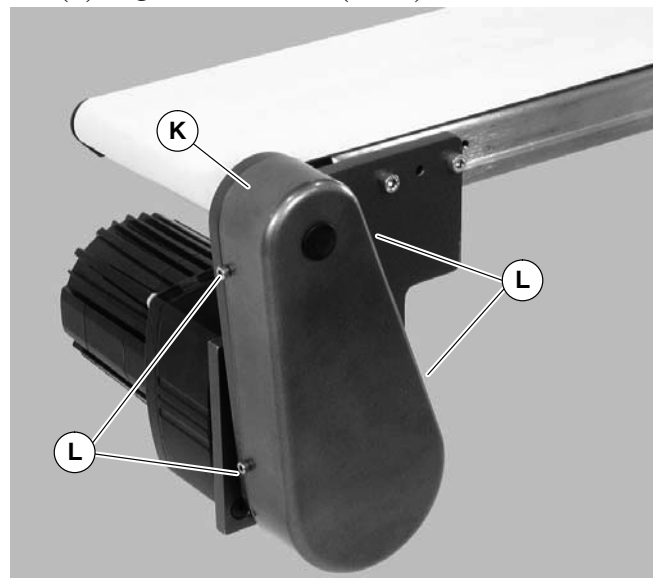

Figure 14

# Preventive Maintenance and Adjustment

## Required Tools

- Hex key wrenches:
  - 2 mm, 2.5 mm, 3 mm, 5 mm
- Adjustable wrench (for hexagon head screws)
- Straight edge
- Torque wrench

## Timing Belt Tensioning



1. Remove four (4) screws (L of Figure 14) and remove cover (K).
2. Loosen tensioner (V of Figure 15).

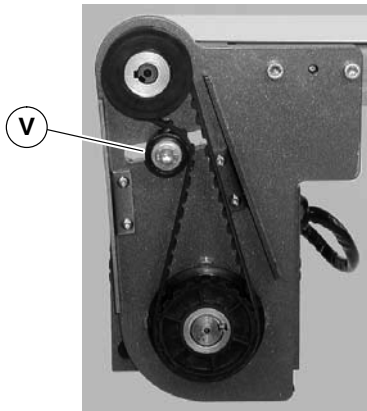
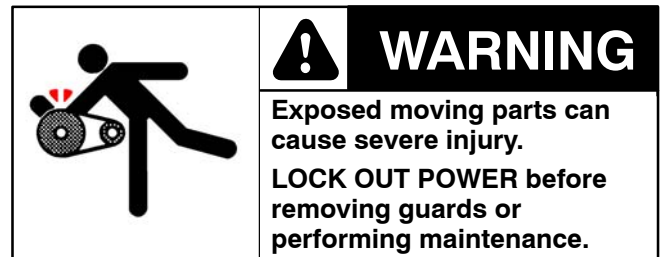

Figure 15

3. Depending on direction of conveyor belt travel (1 or 2 of Figure 13), position belt tensioner (V) as shown. Tension belt to obtain 0.125" (3 mm) deflection for 1.0 lb (456 grams) of force at belt mid-point (W). Tighten tensioner screw to 103 in-lb (12 Nm).
4. Install cover (K of Figure 14) with four (4) screws (L). Tighten to 35 in-lb (4 Nm).

## Timing Belt Replacement



1. Remove four (4) screws (L of Figure 14) and remove cover (K).
2. Loosen tensioner (V of Figure 15).
3. Remove timing belt (P of Figure 16).

**NOTE:** If timing belt does not slide over pulley flange, loosen driven pulley set screws (U of Figure 16) and remove pulley with belt (P). For re-installation, see steps 6 and NO TAG on page 9.

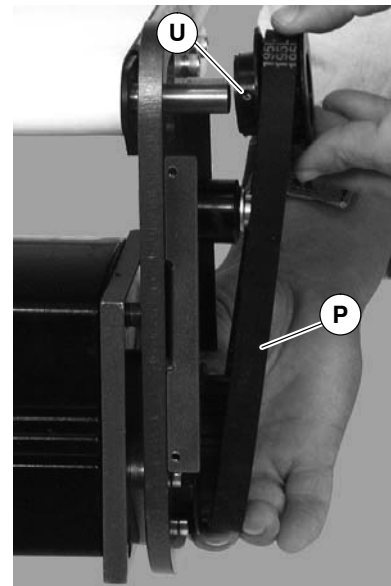
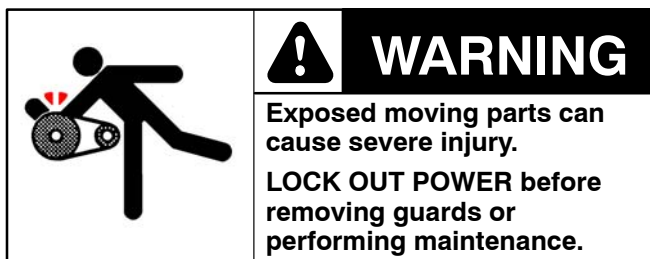

Figure 16

4. Install new timing belt.
5. Depending on direction of conveyor belt travel (1 or 2 of Figure 13), position belt tensioner (V) as shown. Tension belt to obtain 0.125" (3 mm) deflection for 1.0 lb (456 grams) of force at belt mid-point (W). Tighten tensioner screw to 103 in-lb (12 Nm).
6. Install cover (K of Figure 14) with four (4) screws (L). Tighten to 35 in-lb (4 Nm).

# Preventive Maintenance and Adjustment

## Drive or Driven Pulley Replacement



1. Complete steps 1 through 3 of “Timing Belt Replacement” section on page 11.
2. Loosen set screws and remove drive or driven pulley.

**NOTE:** If drive pulley (J of Figure 19) is replaced, wrap timing belt around drive pulley and complete step 3.

3. Complete steps 6 through 9 of “Installation” section on page 9.

## Gear Motor Replacement

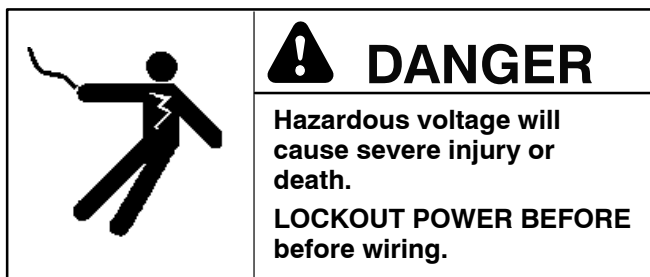
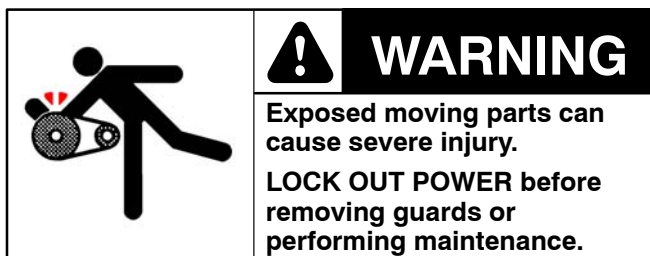

1. For single phase motor, unplug power cord from outlet.
2. For three phase motor:
  - a. Loosen terminal box screws (AF of Figure 17) and remove cover (AG).

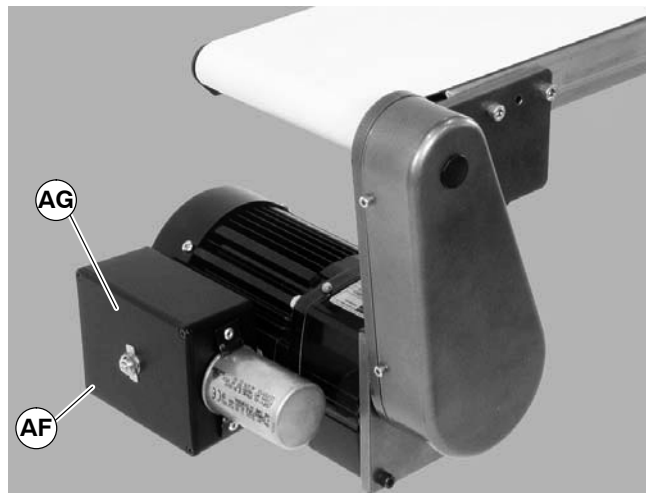

Figure 17

- b. Record incoming wire colors on red, black and blue leads. Loosen wire nuts and remove incoming wires.
  - c. Loosen cord grip and remove cord.
3. For DC variable speed motor, unplug motor cord at disconnect (AH of Figure 18).

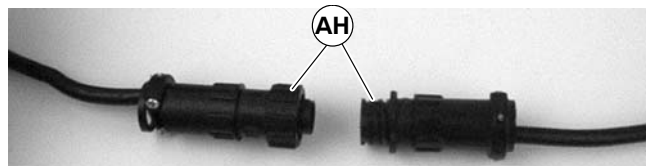

Figure 18

4. Remove four (4) screws (L of Figure 14) and remove cover (K).
5. Loosen tensioner (V of Figure 15).
6. Loosen drive pulley set screws (X of Figure 19). Remove drive pulley (J) and timing belt (P).

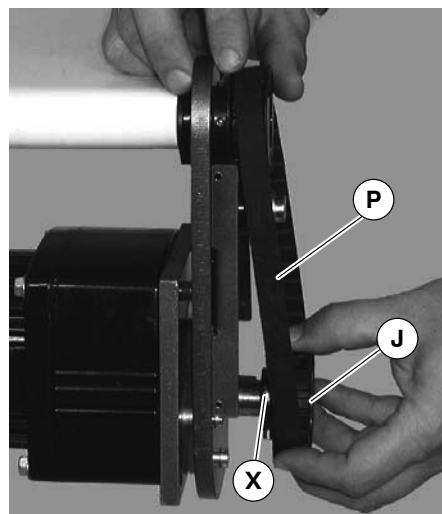

Figure 19

# Preventive Maintenance and Adjustment

7. Remove four (4) gearmotor mounting screws (Q of Figure 20). Remove gearmotor with adapter plate.

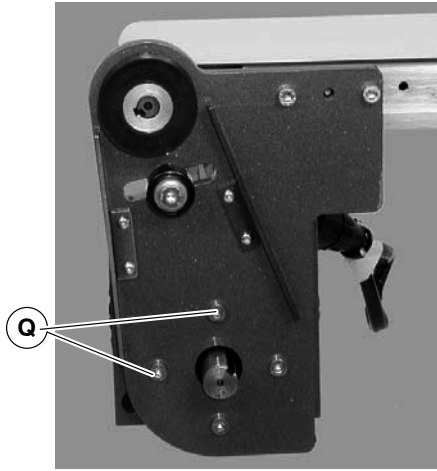

Figure 20

8. Remove four (4) adapter plate screws (AI of Figure 21). Remove adapter plate.

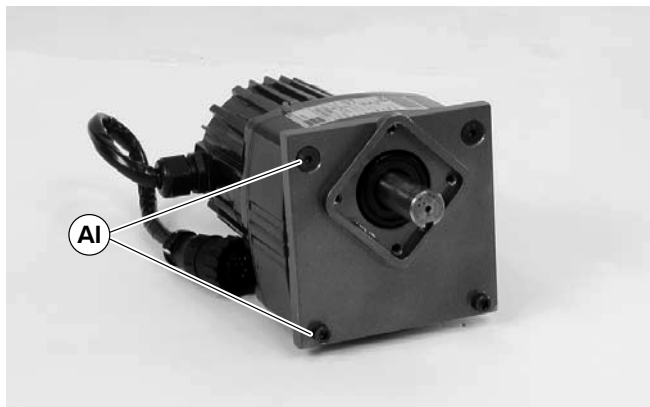

Figure 21

**NOTE:** Gearmotor position on Flat Belt conveyor shown at left (Figure 22). Gearmotor position on Cleated Belt or MPB Series conveyor shown at right (Figure 22).

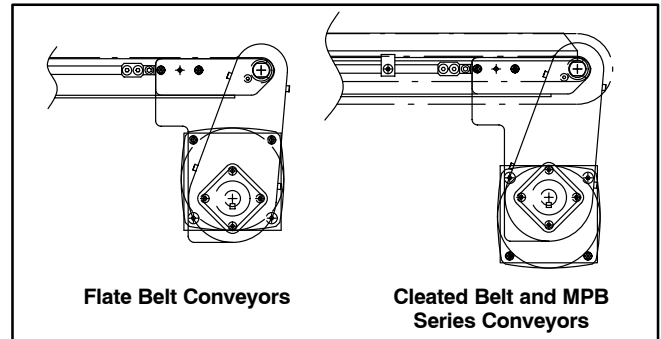

Figure 22

9. Install new gearmotor to adapter plate and mounting bracket. Tighten screws (Q of Figure 20) to 103 in-lb (12 Nm).

**NOTE:** Drive pulley (J of Figure 19) is removed. Wrap timing belt around drive pulley and complete step 10.

10. Complete steps 6 through 9 of “Installation” section on page 9.

11. Replace wiring:

- For a single phase motor, reverse step 1 on page 12.
- For a three phase motor, reverse step 2, on page 12.
- For a DC variable speed motor, reverse step 3 on page 12.

# Service Parts

**NOTE:** For replacement parts other than those shown in this section, contact an authorized Dorner Service Center or the factory. Key Service Parts and Kits are identified by the Performance Parts Kits logo . Dorner recommends keeping these parts on hand.

## 2100, 2200, 4100, 6200 Series and MPB Series Flat Belt Bottom Mount Drive Package

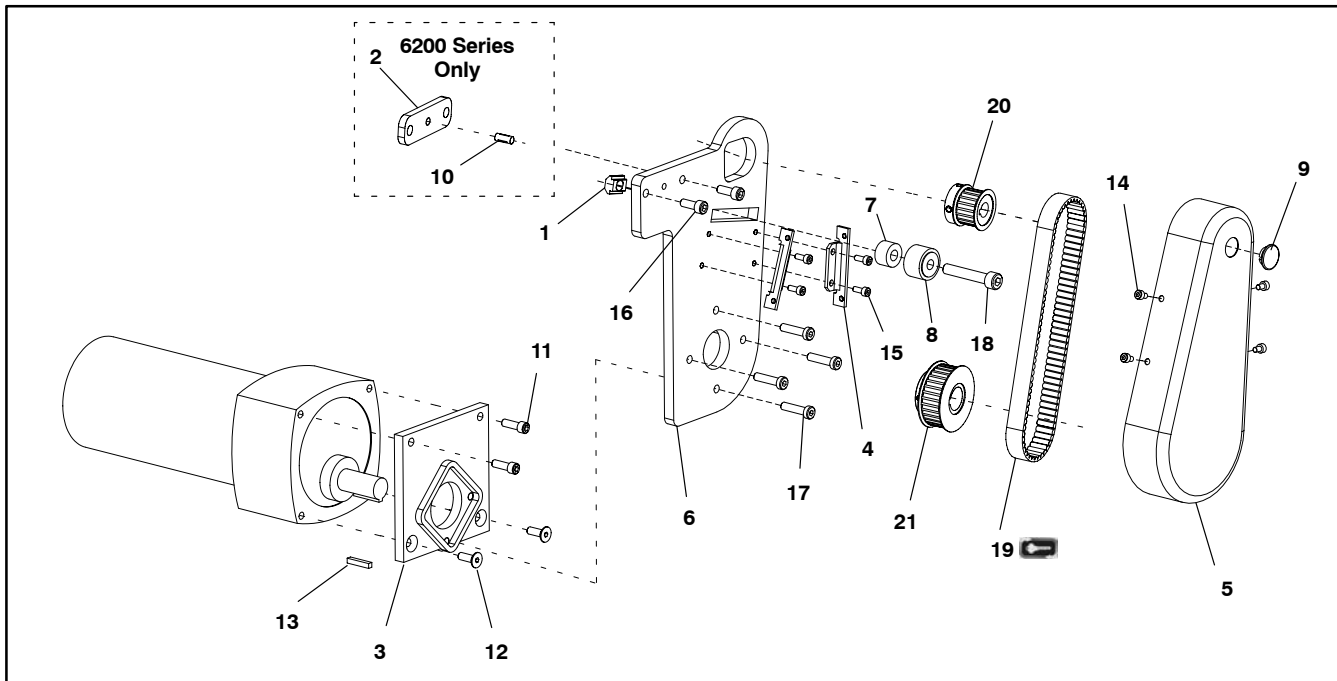

Item	Part Number	Description
1	202390M	Nut, Cam Follower
2	450027M	Adaptor Plate Assembly (6200 Only)
3	450029M	Adaptor Plate Assembly
4	450375M	Cover Mounting Bracket
5	450376M	Drive Guard
6	450443M	Grove Mounting Plate
7	450445	Spacer, Cam Follower
8	802-046	Bearing
9	807-226	Snap-out Plastic Plug
10	807-952	Groove Pin (6200 Only)
11	902-157	Socket Head Screw 1/4-28 x .75"
12	903-161	Flat Head Screw 1/4-28 x .75"
13	912-084	Square Key .188 x 1.5"
14	920406M	Socket Head Screw M4 x 6mm
15	920410M	Socket Head Screw M4 x 10mm
16	920625M	Socket Head Screw M6 x 25mm
	920616M	Socket Head Screw M6 x 16mm (4100 Conveyors)

17	920695M	Socket Low Head Screw M6 x 20mm
18	920845M	Socket Head Screw M8 x 45mm
19 	814-104	Timing Belt, 15mm W x 450mm L
	814-105	Timing Belt, 15mm W x 460mm L
	814-065	Timing Belt, 15mm W x 475mm L
	814-112	Timing Belt, 15mm W x 495mm L
	814-101	Timing Belt, 15mm W x 500mm L
	814-108	Timing Belt, 15mm W x 520mm L
	814-064	Timing Belt, 15mm W x 535mm L
	814-099	Timing Belt, 15mm W x 565mm L
20	450365MP	Driven Pulley, 19Tooth, 12mm bore
	450366MP	Driven Pulley, 22Tooth, 12mm bore
	450367MP	Driven Pulley, 28Tooth, 12mm bore
	450368MP	Driven Pulley, 32Tooth, 12mm bore
21	450434	Drive Pulley, 22Tooth, 0.75" bore
	450435	Drive Pulley, 28Tooth, 0.75" bore
	450436	Drive Pulley, 32Tooth, 0.75" bore
	450437	Drive Pulley, 44Tooth, 0.75" bore
	450438	Drive Pulley, 48Tooth, 0.75" bore

## MPB Series Cleated Belt Bottom Mount Drive Package

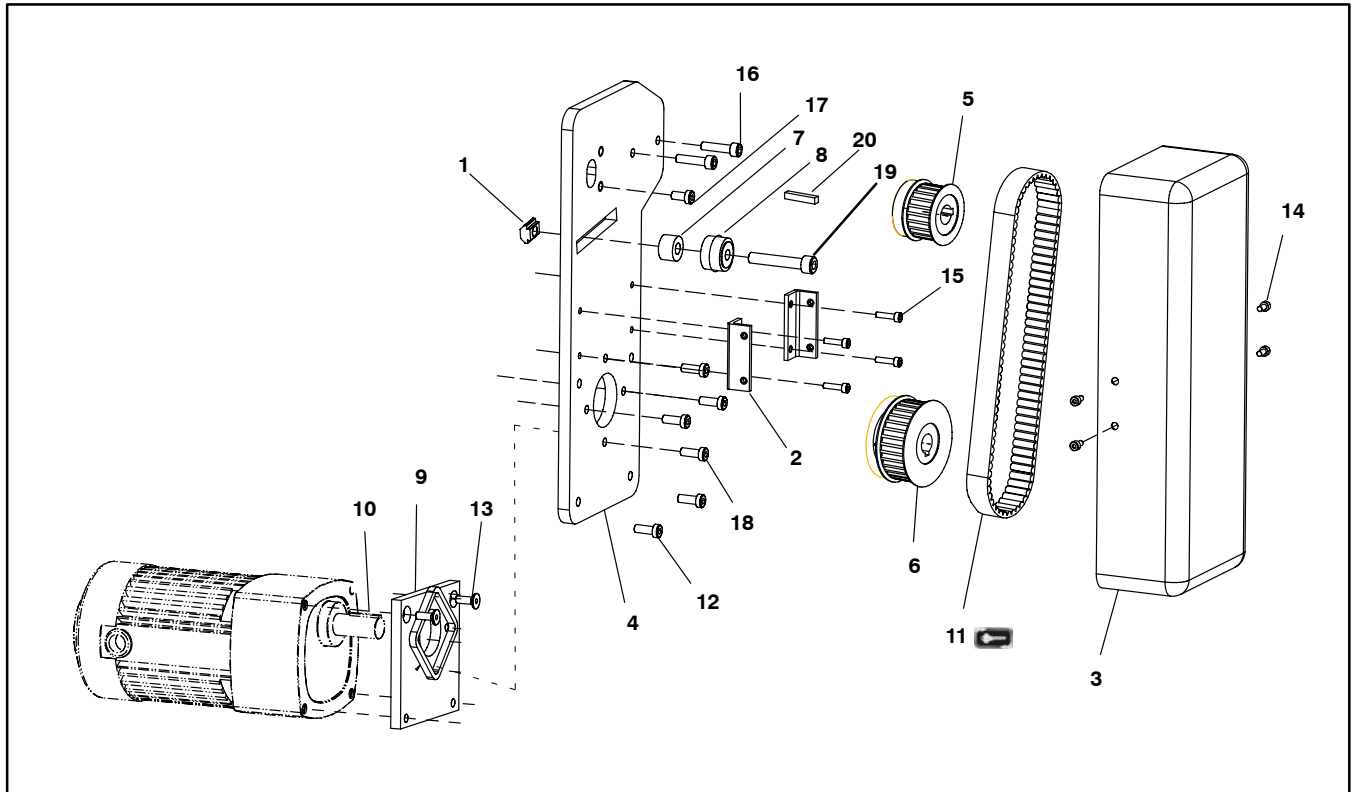

Item	Part Number	Description
1	202390M	Nut Cam Follower
2	243402	Mounting Cover Bracket
3	300871M	Drive Guard
4	243401	Mounting Plate
5	450367MP	Driven Pulley, 28Tooth
	450368MP	Driven Pulley, 32Tooth
6	450434	Drive Pulley, 22Tooth, 0.75" bore
	450435	Drive Pulley, 28Tooth, 0.75" bore
	450436	Drive Pulley, 32Tooth, 0.75" bore
	450437	Drive Pulley, 44Tooth, 0.75" bore
	450438	Drive Pulley, 48Tooth, 0.75" bore
7	450445	Spacer
8	802-046	Bearing
9	450029M	Adaptor Plate Assembly
10	912-084	Square Key .188 x 1.5"

11	814-101	Timing Belt, 15mm W x 500mm L
	814-108	Timing Belt, 15mm W x 520mm L
	814-064	Timing Belt, 15mm W x 535mm L
	814-099	Timing Belt, 15mm W x 565mm L
	814-109	Timing Belt, 15mm W x 580mm L
	814-115	Timing Belt, 15mm W x 600mm L
	814-110	Timing Belt, 15mm W x 615mm L
12	902-157	Socket Head Screw 1/4-28 x .75"
13	903-161	Flat Head Screw 1/4-28 x .75"
14	920408M	Socket Head Screw M4 x 8mm
15	920416M	Socket Head Screw M4 x 16mm
16	920625M	Socket Head Screw M6 x 25mm
17	920692M	Stabilization Screw M6 x 12mm Low Hd
18	920693M	Socket Low Head Screw M6 x 16mm
19	920845M	Socket Head Screw M8 x 45mm
20	980422M	Square Key 4mm x 22mm

# Service Parts

## 4100 Series Adapter Package

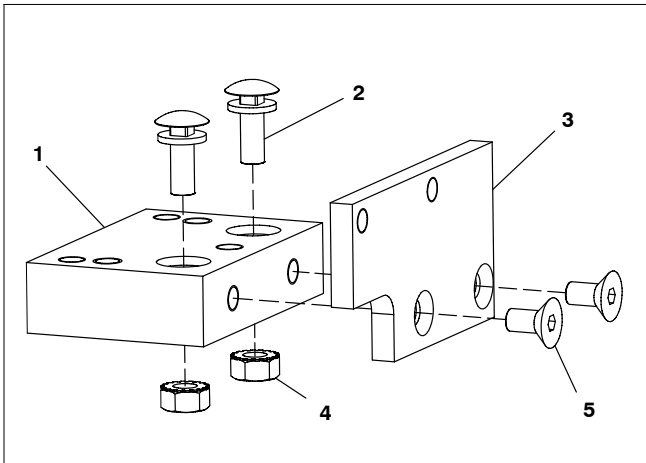

Item	Part No.	Part Description
1	609486	Mounting Block 1" (25mm)
	609487	Mounting Block 2" (51mm)
	609488	Mounting Block 3" (76mm)
	609479	Mounting Block 4" (102mm)
	609480	Mounting Block 5" (127mm)
	609481	Mounting Block 6" (152mm)
	609482	Mounting Block 7" (178mm)
	609483	Mounting Block 8" (203mm)
	609484	Mounting Block 10" (254mm)
	609485	Mounting Block 12" (305mm)
2	613602P	Bolt & Flat Washer Assembly
3	450374	Drive Adapter Plate
4	910-126	Hex Nut with Lock Washer
5	930612M	Flat Head Screw M6 x 12mm

## Gear Motor

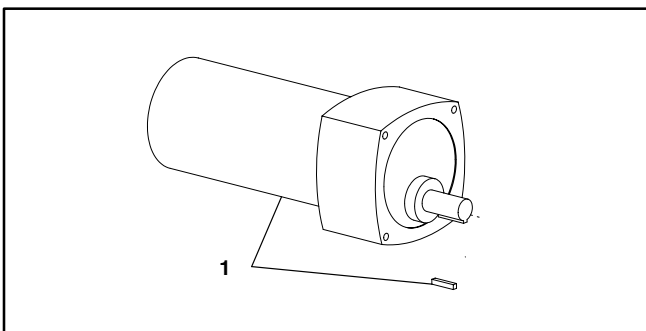

Item	Part No.	Part Description
1	62M180PS411FN	Motor, 0.08hp (0.06Kw), 10 RPM, 115VAC, 60Hz, 1-Phase
	62M180PS411FR	Motor, 0.08hp (0.06Kw), 10 RPM, 115VAC, 60Hz, 1-Phase w/reversing switch
	62M060PS411FN	Motor, 0.17hp (0.13Kw), 29 RPM, 115VAC, 60Hz, 1-Phase
	62M060PS411FR	Motor, 0.17hp (0.13Kw), 29 RPM, 115VAC, 60Hz, 1-Phase w/reversing switch
	62M060PS423FN	Motor, 0.25hp (0.19Kw), 29 RPM, 230VAC, 60Hz, 3-Phase
	62M030PS411FN	Motor, 0.17hp (0.13Kw), 58 RPM, 115VAC, 60Hz, 1-Phase
	62M030PS411FR	Motor, 0.17hp (0.13Kw), 58 RPM, 115VAC, 60Hz, 1-Phase w/reversing switch
	62M030PS423FN	Motor, 0.25hp (0.19Kw), 58 RPM, 230VAC, 60Hz, 3-Phase
	62M020PS411FN	Motor, 0.17hp (0.13Kw), 86 RPM, 230VAC, 60Hz, 1-Phase
	62M020PS411FR	Motor, 0.17hp (0.13Kw), 86 RPM, 115VAC, 60Hz, 1-Phase w/reversing switch
	62M010PS411FN	Motor, 0.17hp (0.13Kw), 173 RPM, 115VAC, 60Hz, 1-Phase
	62M010PS411FR	Motor, 0.17hp (0.13Kw), 173 RPM, 115VAC, 60Hz, 1-Phase w/reversing switch
	62M010PS423FN	Motor, 0.25hp (0.19Kw), 173 RPM, 230VAC, 60Hz, 3-Phase
	62M005PS411FN	Motor, 0.17hp (0.13Kw), 345 RPM, 230VAC, 60Hz, 1-Phase
	62M005PS411FR	Motor, 0.17hp (0.13Kw), 345 RPM, 115VAC, 60Hz, 1-Phase w/reversing switch
	62M180PSD3DEN	Motor, 0.12hp (0.09Kw), 14 RPM, 130VDC
	62M060PSD3DEN	Motor, 0.25hp (0.19Kw), 42 RPM, 130VDC
	62M030PSD3DEN	Motor, 0.25hp (0.19Kw), 83 RPM, 130VDC
	62M020PSD3DEN	Motor, 0.25hp (0.19Kw), 125 RPM, 130VDC
	62M010PSD3DEN	Motor, 0.25hp (0.19Kw), 250 RPM, 130VDC
62M005PSD3DEN	Motor, 0.25hp (0.19Kw), 500 RPM, 130VDC	





# Return Policy

Returns must have prior written factory authorization or they will not be accepted. Items that are returned to Dorner without authorization will not be credited nor returned to the original sender. When calling for authorization, please have the following information ready for the Dorner factory representative or your local distributor:

1. Name and address of customer.
2. Dorner part number(s) of Item(s) being returned.
3. Reason for return.
4. Customer's original order number used when ordering the item(s).
5. Dorner or distributor invoice number.

A representative will discuss action to be taken on the returned items and provide a Returned Goods Authorization number for reference.

There will be a return charge on all new undamaged items returned for credit where Dorner was not at fault. Dorner is not responsible for return freight on such items.

### **Conveyors and conveyor accessories**

Standard catalog conveyors	30%
MPB Series, cleated and specialty belt conveyors	50%
7400 & 7600 Series conveyors	non-returnable items
Engineered special products	case by case
Drives and accessories	30%
Sanitary stand supports	non-returnable items

### **Parts**

Standard stock parts	30%
MPB, cleated and specialty belts	non-returnable items

Returns will not be accepted after 60 days from original invoice date.

The return charge covers inspection, cleaning, disassembly, disposal and reissuing of components to inventory.

If a replacement is needed prior to evaluation of returned item, a purchase order must be issued. Credit (if any) is issued only after return and evaluation is complete.

Dorner has representatives throughout the world. Contact Dorner for the name of your local representative. Our Technical Sales, Catalog Sales and Service Teams will gladly help with your questions on Dorner products.

For a copy of Dorner's Warranty, contact factory, distributor, service center or visit our website at [www.dorner.com](http://www.dorner.com).

**For replacement parts, contact an authorized  
Dorner Service Center or the factory.**

# **DORNER**<sup>®</sup>

Dorner Mfg. Corp. reserves the right to change or discontinue products without notice. All products and services are covered in accordance with our standard warranty. All rights reserved. ©Dorner Mfg. Corp. 2000

### **DORNER MFG. CORP.**

975 Cottonwood Ave., PO Box 20  
Hartland, WI 53029-0020 USA

**USA**  
**TEL 1-800-397-8664 (USA)**  
**FAX 1-800-369-2440 (USA)**  
**Internet: [www.dorner.com](http://www.dorner.com)**

**Outside the USA:**  
**TEL 1-262-367-7600**  
**FAX 1-262-367-5827**