

2200, 2100 & 6200 Series Center Mount Drive Package for Standard & Heavy Load 60 Hz Gearmotors

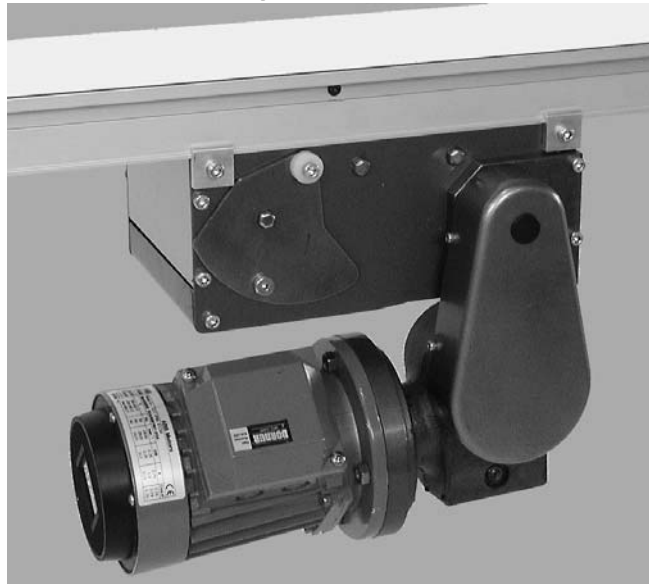



Table of Contents

Warnings – General Safety	2	Preventative Maintenance & Adjustment	7
Introduction	2	Required Tools	7
Product Description	3	Timing Belt Tensioning	7
Specifications	3	Timing Belt Replacement	8
Installation	5	Drive or Driven Pulley Replacement	8
Required Tools	5	Gear Reducer Replacement	8
Mounting	5	Motor Replacement	10
		Service Parts	11
		Return Policy	12

Warnings – General Safety



	WARNING	
<p>The safety alert symbol, black triangle with white exclamation, is used to alert you to potential personal injury hazards.</p>		

		WARNING
<p>Gearmotors may be HOT. DO NOT TOUCH Gearmotors.</p>		

		DANGER
<p>Climbing, sitting, walking or riding on conveyor will cause severe injury. KEEP OFF CONVEYORS.</p>		

		WARNING
<p>Exposed moving parts can cause severe injury. REPLACE ALL GUARDS BEFORE RUNNING CONVEYOR.</p>		

		DANGER
<p>Do NOT OPERATE CONVEYORS IN AN EXPLOSIVE ENVIRONMENT.</p>		

		WARNING
<p>Dorner cannot control the physical installation and application of conveyors. Taking protective measures is the responsibility of the user.</p> <p>When conveyors are used in conjunction with other equipment or as part of a multiple conveyor system, CHECK FOR POTENTIAL PINCH POINTS and other mechanical hazards before system start-up.</p>		

		WARNING
<p>Exposed moving parts can cause severe injury. LOCK OUT POWER before removing guards or performing maintenance.</p>		

Introduction

IMPORTANT: Some illustrations may show guards removed. Do NOT operate equipment without guards.

Upon receipt of shipment:

- Compare shipment with packing slip. Contact factory regarding discrepancies.
- Inspect packages for shipping damage. Contact carrier regarding damage.
- Accessories may be shipped loose. See accessory instructions for installation.

Dorner 2100 Series conveyors are covered by the following patent numbers: 5131529, 5174435, and corresponding patents and patent applications in other countries.

Dorner 6200 Series conveyors are covered by patent number 5174435 and corresponding patents and patent applications in other countries.

Dorner's Limited Warranty applies.

Dorner reserves the right to make changes at any time without notice or obligation.

Dorner has convenient, pre-configured kits of Key Service Parts for all conveyor products. These time saving kits are easy to order, designed for fast installation, and guarantee you will have what you need when you need it. Key Parts and Kits are marked in the Service Parts section of this manual with the Performance Parts Kits logo .

Product Description

Refer to Figure 1 for typical components.

Typical Components	
A	Conveyor
B	Mounting Bracket
C	Gearmotor
D	Timing Belt Tensioner
E	Cover
F	Timing Belt
G	Drive Pulley
H	Driven Pulley

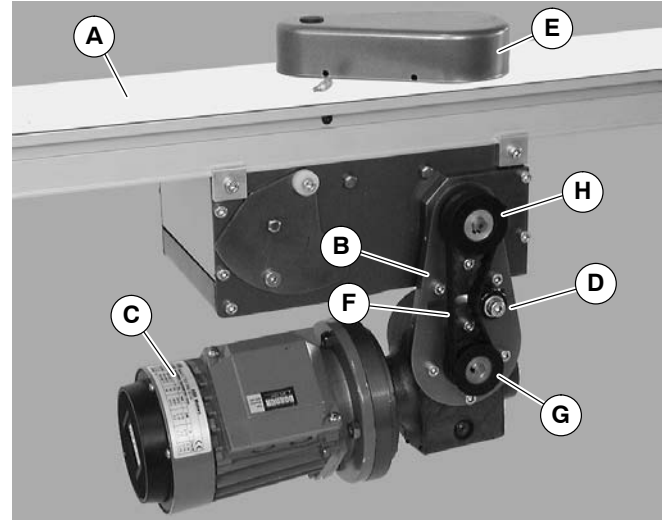

Figure 1

Specifications

Gearmotor Mounting Package Models:

Example:

2 M 1 H S WW A 32 32

- 2 = 2100 Series Conveyor
- M = 6100 Series Conveyor
- 1 = Type 1, Vertical Mount;
- H = Heavy Load
- S = Standard Load
- WW = Conveyor Width Reference*
- A = Mount Position = A or D (see detail to the right)
- 32 = Drive Pulley (see Tables 2, 3 & 4)
- 32 = Driven Pulley (see Tables 2, 3 & 4)
- Output Shaft Type = 90°
- Language Code = US English

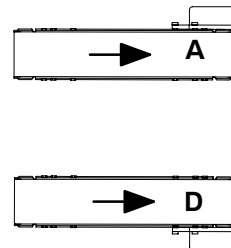

* See "Ordering and Specifications" Catalog for details.

Table 1: Gearmotor Specifications

Item	Standard Load Gearmotor			Heavy Load Gearmotor			
	Single-Phase	Three Phase	DC Variable Speed	Single-Phase	Three Phase	VFD Variable Speed	DC Variable Speed
Output Power	0.25 hp (0.19 kw)			0.5 hp (0.37 kw)			
Input Voltage	115VAC	208 – 230/460 VAC	130VDC	115VAC	208 – 230/460 VAC	230 VAC	90VDC
Input Frequency	60Hz		N/A	60Hz		10 – 60Hz	N/A
Input Current (Amperes)	5.0	1.2/0.6	2.2	7.4	2.1 – 2/1	1.6	5.0
Gearmotor Ratios	5:1, 10:1, 20:1, 40:1, 60:1			5:1, 10:1, 20:1, 40:1, 60:1			
Frame Size	NEMA 42CZ			NEMA 56C			
Motor Type	Totally enclosed, Fan cooled			Totally enclosed, Fan cooled			

Specifications

Table 1: Belt Speeds for Standard & Heavy Load Fixed Speed 90° 60 Hz Gearmotors

Standard Load Gearmotors				Heavy Load Gearmotors				Belt Speed		Drive Pulley	Driven Pulley
Part Number	RPM	In-lb	N-m	Part Number	RPM	In-lb	N-m	Ft/min	M/min		
32M060HL4(vp)F(n)	29	226	25.5	32M060HS4(vp)F(n)	29	226	25.5	6	1.8	19	32
32M060HL4(vp)F(n)	29	226	25.5	32M060HS4(vp)F(n)	29	226	25.5	10	3.0	32	32
32M040HL4(vp)F(n)	43	237	26.8	32M040HS4(vp)F(n)	43	247	27.9	15	4.6	32	32
32M040HL4(vp)F(n)	43	237	26.8	32M040HS4(vp)F(n)	43	247	27.9	23	7.0	48	32
32M020HL4(vp)F(n)	86	142	16	32M020HS4(vp)F(n)	86	248	27.9	30	9.1	32	32
32M020HL4(vp)F(n)	86	142	16	32M020HS4(vp)F(n)	86	248	27.9	45	13.7	48	32
32M010HL4(vp)F(n)	173	78	8.8	32M010HS4(vp)F(n)	173	156	17.6	61	18.6	32	32
32M010HL4(vp)F(n)	173	78	8.8	32M010HS4(vp)F(n)	173	156	17.6	91	27.7	48	32
32M005HL4(vp)F(n)	345	41	4.6	32M005HS4(vp)F(n)	345	81	9.1	121	36.9	32	32
32M005HL4(vp)F(n)	345	41	4.6	32M005HS4(vp)F(n)	345	81	9.1	154	46.9	28	22
32M005HL4(vp)F(n)	345	41	4.6	32M005HS4(vp)F(n)	345	81	9.1	181	55.2	48	28
32M005HL4(vp)F(n)	345	41	4.6	32M005HS4(vp)F(n)	345	81	9.1	208	63.4	48	28
32M005HL4(vp)F(n)	435	41	4.6	32M005HS4(vp)F(n)	345	81	9.1	264	80.5	48	22

(vp) = voltage and phase

11 = 115 V, 1-phase

23 = 208 – 230/460 V, 3-phase

Table 2: Belt Speeds for Standard & Heavy Load Variable Speed 90° DC Gearmotors

Standard Load Gearmotors				Heavy Load Gearmotors				Belt Speed		Drive Pulley	Driven Pulley
Part Number	RPM	In-lb	N-m	Part Number	RPM	In-lb	N-m	Ft/min	M/min		
32M060HLD3DEN	42	198	22.4	32M060HSD9DEN	42	198	22.4	1.0 – 9	0.3 – 2.6	19	32
32M060HLD3DEN	42	198	22.4	32M060HSD9DEN	42	198	22.4	1.8 – 15	0.5 – 4.5	32	32
32M040HLD3DEN	63	163	18.4	32M040HSD9DEN	63	215	24.3	2.6 – 22	0.8 – 6.7	32	32
32M020HLD3DEN	125	98	11.1	32M020HSD9DEN	125	196	22.1	5.3 – 44	1.6 – 13	32	32
32M010HLD3DEN	250	54	6.1	32M010HSD9DEN	250	108	12.2	10 – 88	3.2 – 27	32	28
32M010HLD3DEN	250	54	6.1	32M010HSD9DEN	250	108	12.2	18 – 150	5.5 – 46	48	32
32M005HLD3DEN	500	28	3.2	32M005HSD9DEN	500	56	6.3	21 – 176	6.4 – 54	32	16
32M005HLD3DEN	500	28	3.2	32M005HSD9DEN	500	56	6.3	27 – 224	7.3 – 61	28	22
32M005HLD3DEN	500	28	3.2	32M005HSD9DEN	500	56	6.3	31 – 255	9.3 – 78	32	22

Table 3: Belt Speeds for Heavy Load Variable Speed 90° VFD Gearmotors

Heavy Load Gearmotors				Belt Speed		Drive Pulley	Driven Pulley
Part Number	RPM	In-lb	N-m	Ft/min	M/min		
32M060HS423EN	29	226	25.5	0.7 – 6	0.2 – 1.8	19	32
32M060HS423EN	29	226	25.5	1.2 – 10	0.4 – 3.1	32	32
32M040HS423EN	43	247	27.9	1.8 – 15	0.6 – 4.6	32	32
32M020HS423EN	86	248	27.9	3.6 – 30	1.1 – 9.2	32	32
32M010HS423EN	173	156	17.6	7 – 61	2.2 – 18	32	32
32M010HS423EN	173	156	17.6	12 – 104	3.8 – 32	48	28
32M005HS423EN	345	81	9.1	14 – 121	4.4 – 37	32	32
32M005HS423EN	345	81	9.1	23 – 190	7 – 58	44	28
32M005HS423EN	345	81	9.1	29 – 242	9 – 74	44	22

NOTE: For belt speed other than those listed, contact factory for details.

Required Tools

- Hex key wrenches:
2 mm, 2.5 mm, 3 mm, 5 mm
- Straight edge
- Torque wrench

Mounting



NOTE: Type 1 mounting package shown below left (Figure 2.) Type 2 mounting package shown below right (Figure 2.)

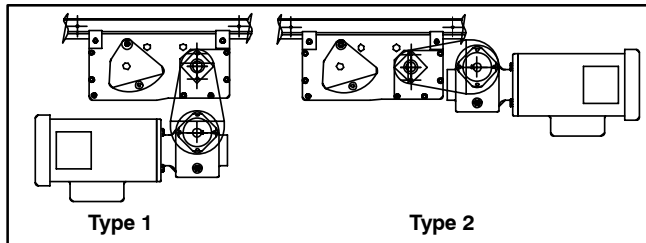

Figure 2

NOTE: For Type 1 mounting package, the gearmotor may be operated in positions 1 or 4 (Figure 3).

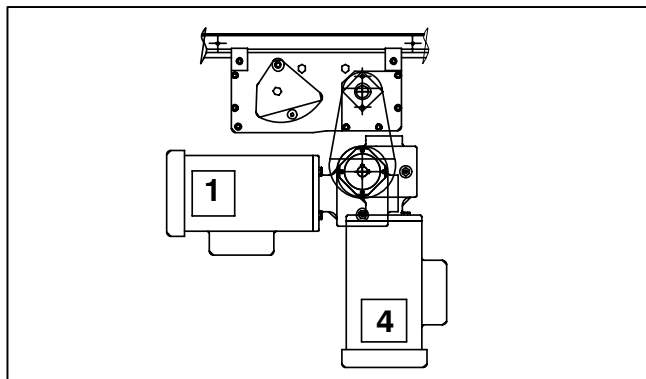

Figure 3

1. Gather installation components (Figure 4)

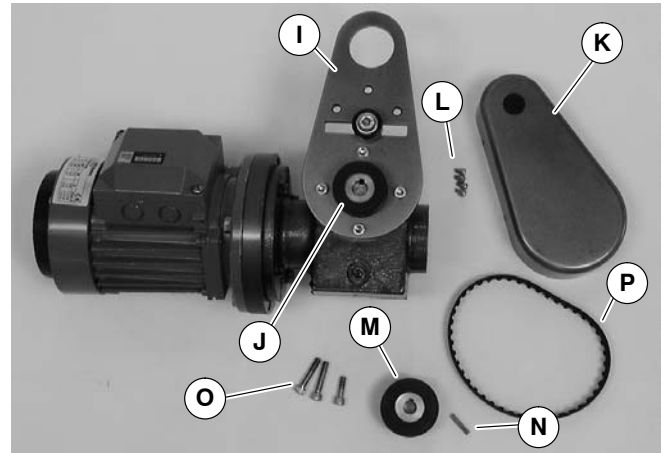

Figure 4

Installation Component List

I	Mount Assembly
J	Drive Pulley
K	Cover
L	M4 Socket Head Screws (4x)
M	Driven Pulley
N	Key
O	M6 Socket Head Screws (3x)
P	Timing Belt

NOTE: Type 1 mounting package shown (Figure 4), Type 2 mounting package similar.

2. If required, change gearmotor position by removing four (4) screws (Q of Figure 5). Rotate gearmotor to other position and replace screws (Q). Tighten to 103 in-lb (12 Nm).

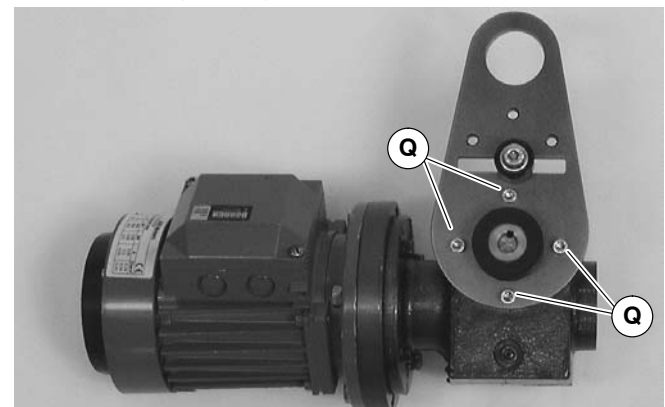

Figure 5

Installation

3. Locate drive output shaft (S of Figure 6) and remove two (2) screws (R).

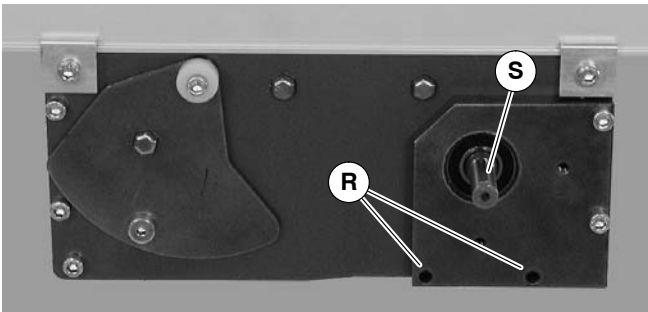

Figure 6

4. Attach mount assembly (I of Figure 7) with mounting screws (O). Install long screws on bottom. Tighten screws to 80 in-lb (9 Nm.).

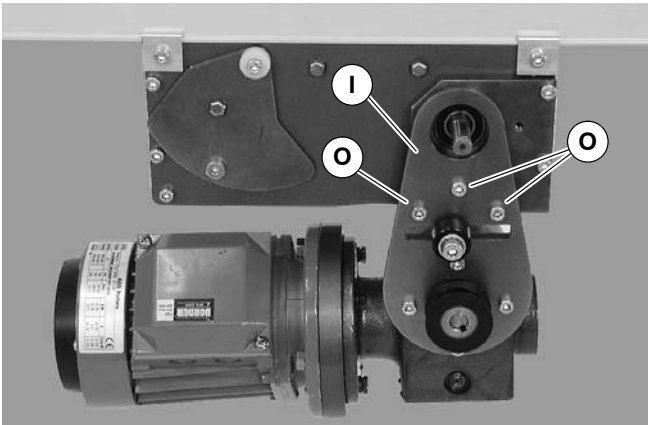

Figure 7



5. Install key (N of Figure 8).

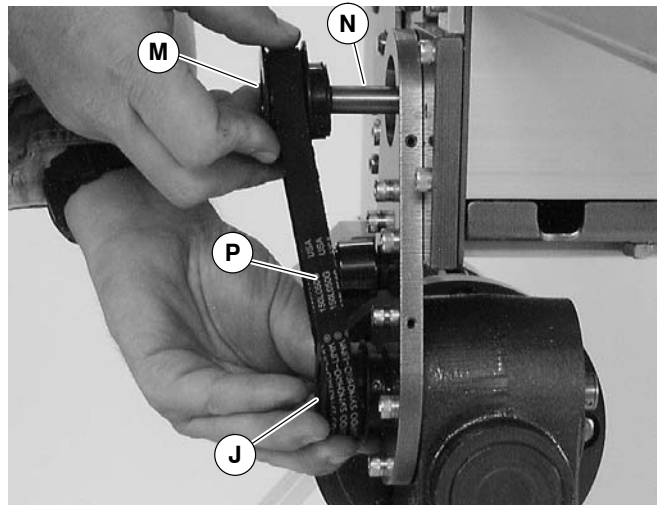

Figure 8

6. Wrap timing belt (P) around driven pulley (M) and drive pulley (J). Install driven pulley (M) onto conveyor shaft.
7. Using a straight edge (T of Figure 9), align driven pulley (M) with drive pulley (J). Tighten driven pulley set screws (U).

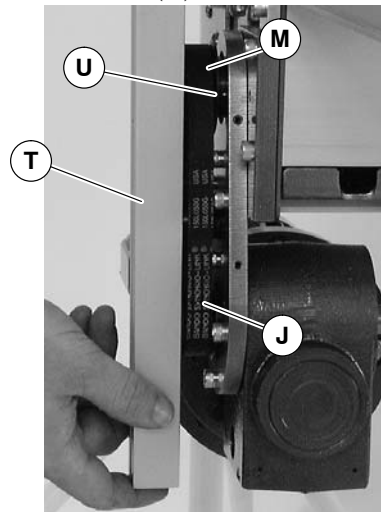

Figure 9

8. Depending on direction of conveyor belt travel (1 or 2 of Figure 10), position belt tensioner (V) as shown. Tension belt to obtain .125" (3 mm) deflection for 1.0 lb (456 grams) of force at belt mid-point (W). Tighten tensioner screw to 103 in-lb (12 Nm).

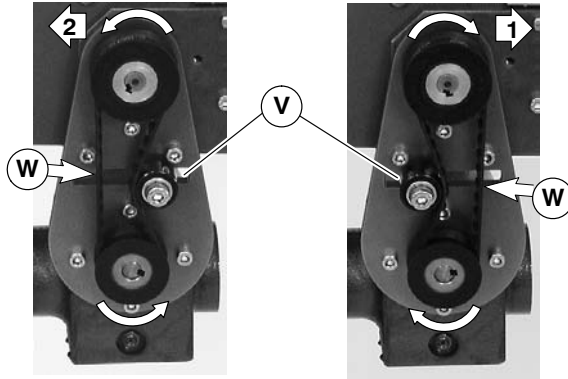

Figure 10

9. Install cover (K of Figure 11) with four (4) screws (L). Tighten screws to 35 in-lb (4 Nm).

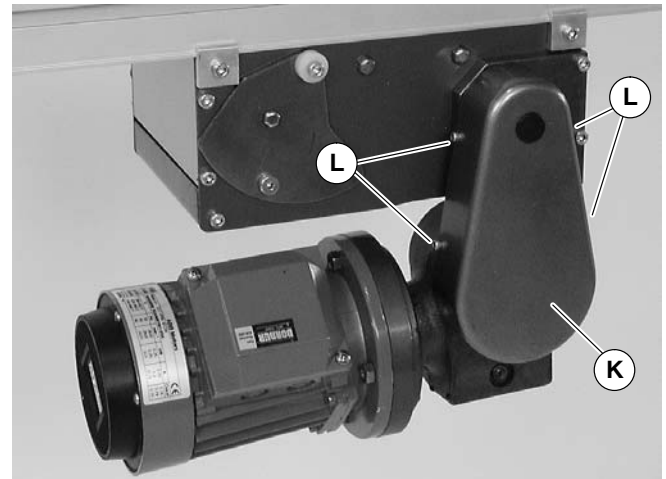

Figure 11

Preventive Maintenance and Adjustment

Required Tools

- Hex key wrenches:
2 mm, 2.5 mm, 3 mm, 5 mm
- Adjustable wrench (for hexagon head screws)
- Straight edge
- Torque wrench

Timing Belt Tensioning

		<h2>WARNING</h2>

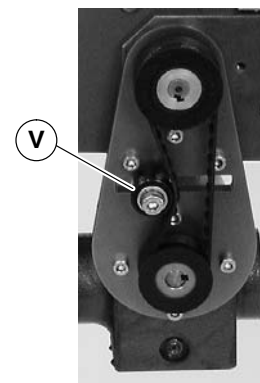
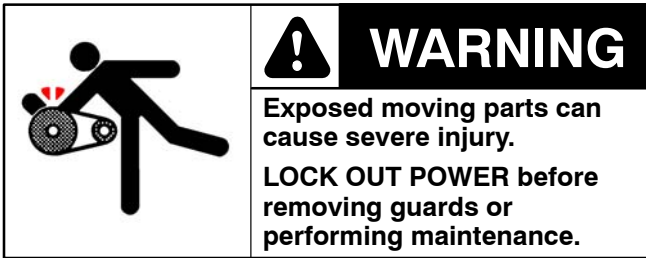

Figure 12

1. Remove four (4) screws (L of Figure 11) and remove cover (K).
2. Loosen tensioner (V of Figure 12).
3. Depending direction of conveyor belt travel (1 or 2 of Figure 10), position belt tensioner (V) as shown. Tension belt to obtain .125" (3 mm) deflection for 1.0 lb (456 grams) of force at belt mid-point (W). Tighten tensioner screw to 103 in-lb (12 Nm).
4. Install cover (K of Figure 11) with four (4) screws (L). Tighten screws to 35 in-lb (4 Nm).

Preventive Maintenance and Adjustment

Timing Belt Replacement



1. Remove four (4) screws (L of Figure 11) and remove cover (K).
2. Loosen tensioner (V of Figure 12).
3. Remove timing belt (P of Figure 13).

NOTE: If timing belt does not slide over pulley flange, loosen driven pulley set screws (U of Figure 13) and remove pulley with belt (P). For re-installation, see steps 6 and 7 on page 6.

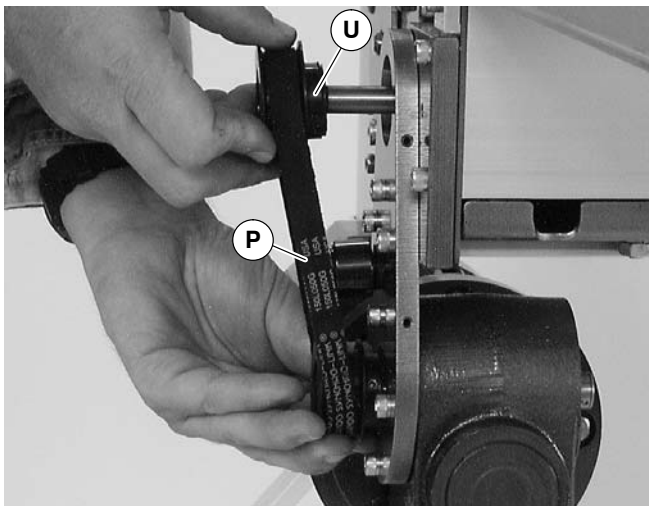

Figure 13

4. Install new timing belt.
5. Depending direction of conveyor belt travel (1 or 2 of Figure 10), position belt tensioner (V) as shown. Tension belt to obtain .125" (3 mm) deflection for 1.0 lb (456 grams) of force at belt mid-point (W). Tighten tensioner screw to 103 in-lb (12 Nm).
6. Install cover (K of Figure 11) with four (4) screws (L). Tighten screws to 35 in-lb (4 Nm).

Drive or Driven Pulley Replacement



1. Complete steps 1 through 3 of "Timing Belt Replacement" section on page 8.
2. Loosen set screws and remove drive or driven pulley.

NOTE: If drive pulley (J of Figure 14) is replaced, wrap timing belt around drive pulley and complete step 3.

3. Complete steps 6 through 9 of "Installation" section on page 6.

Gear Reducer Replacement



1. Remove four (4) screws (L of Figure 11) and remove cover (K).
2. Loosen tensioner (V of Figure 12).
3. Loosen drive pulley set screws (X of Figure 14). Remove drive pulley (J) and timing belt (P).

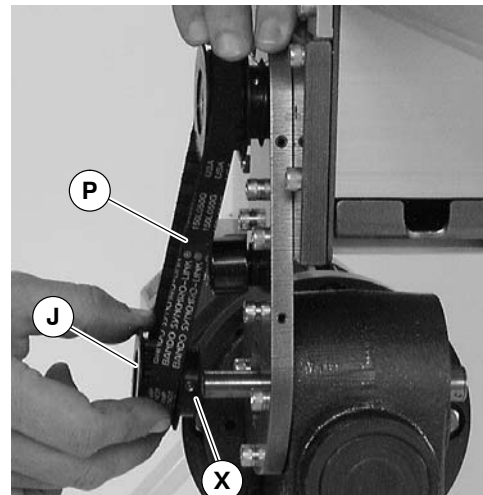

Figure 14

Preventive Maintenance and Adjustment

4. Remove four (4) gear reducer mounting screws (Q of Figure 15). Remove gearmotor.

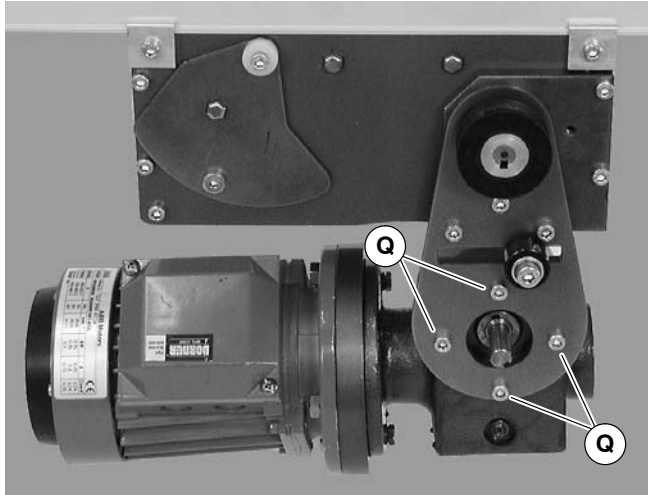

Figure 15

5. Remove four screws (Y of Figure 16). Detach motor (Z) from gear reducer (AA). Retain motor output shaft key (AB).

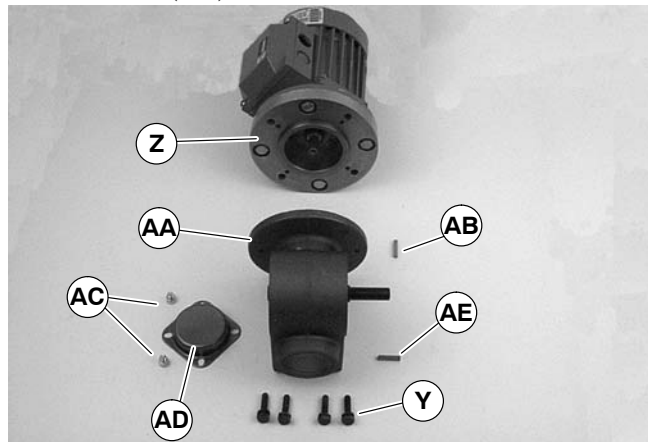

Figure 16

6. Remove two (2) screws (AC) and detach output shaft cover (AD).
7. Loosen six (6) set screws (AF of Figure 17). Remove drive shaft (AG) and key (AH).
8. Remove gear reducer output shaft key (AE).

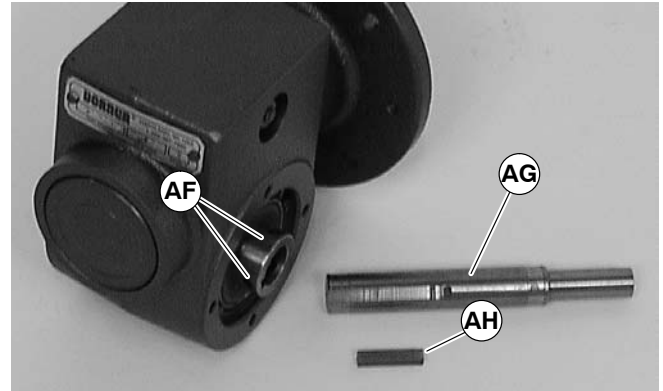

Figure 17

9. Apply grease (AI of Figure 18) to shaft.

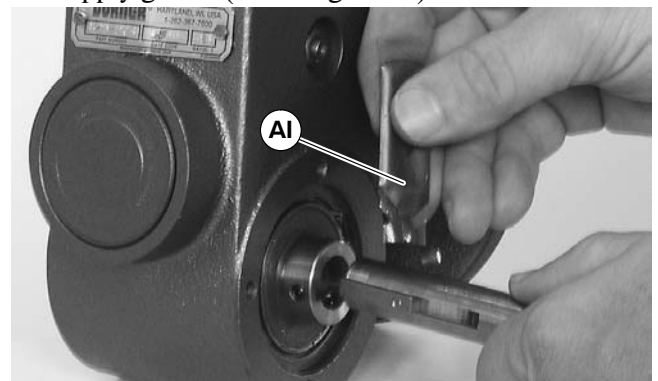

Figure 18

10. Replace the original shaft (AG of Figure 17) and key (AH) into new gear reducer. Tighten set screws (AF) to 26 in-lb (3 Nm).

IMPORTANT: Be extremely careful when coupling motor to gear reducer. Avoid misalignment and forcing the connection causing possible permanent gear reducer seal damage.

11. With key (AB of Figure 16) in keyway, slide motor (Z) and gear reducer (AA) together. Install screws (Y) and tighten.
12. Install gearmotor to mounting bracket and tighten screws (Q of Figure 15) to 103 in-lb (12 Nm).

NOTE: Drive pulley (J of Figure 14) is removed. Wrap timing belt around drive pulley and complete step 13.

13. Complete steps 6 through 9 of "Installation" section on page 6.

Preventive Maintenance and Adjustment

Motor Replacement

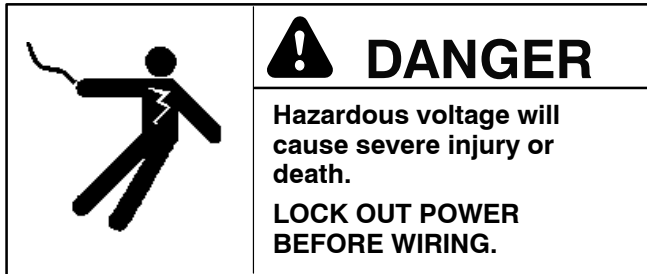

1. For single phase motor, unplug power cord from outlet.
2. For three phase motor:
 - a. Loosen terminal box screws (AJ of Figure 19) and remove cover (AK).

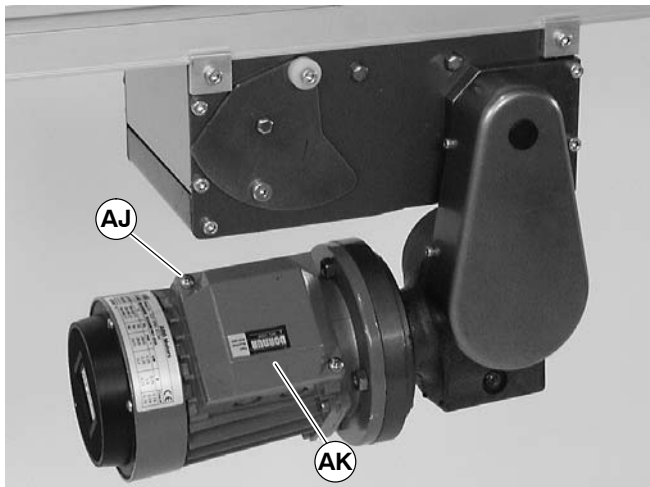

Figure 19

- b. Record wire colors on terminals 1, 2 and 3. Loosen wire nuts and remove wires 1, 2 and 3.
 - c. Loosen cord grip and remove cord.
3. For DC variable speed motor, unplug motor cord at disconnect (AL of Figure 20).

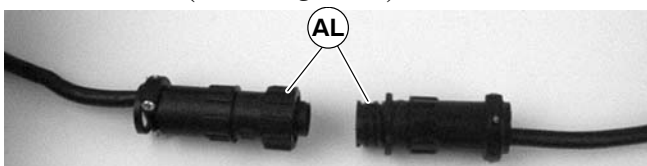

Figure 20

4. Remove four screws (Y of Figure 21). Detach motor (Z) from gear reducer (AA). Retain motor output shaft key (AB).

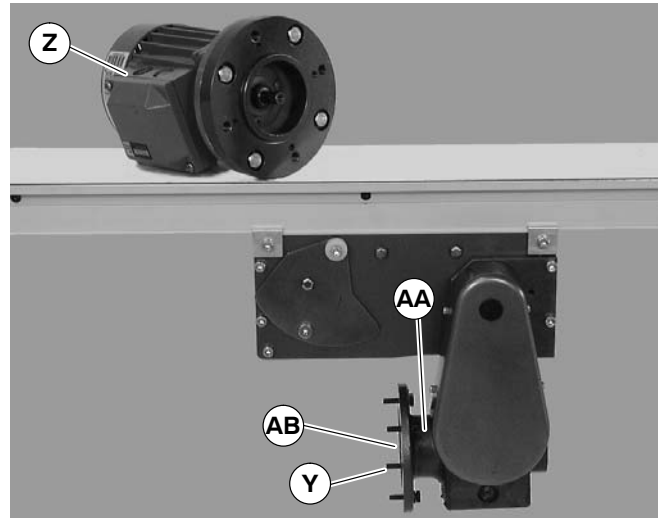

Figure 21

IMPORTANT: Be extremely careful when coupling motor to gear reducer. Avoid misalignment and forcing the connection causing possible permanent gear reducer seal damage.

5. With key (AB of Figure 22) in keyway, slide motor and gear reducer together. Install screws (Y) and tighten.

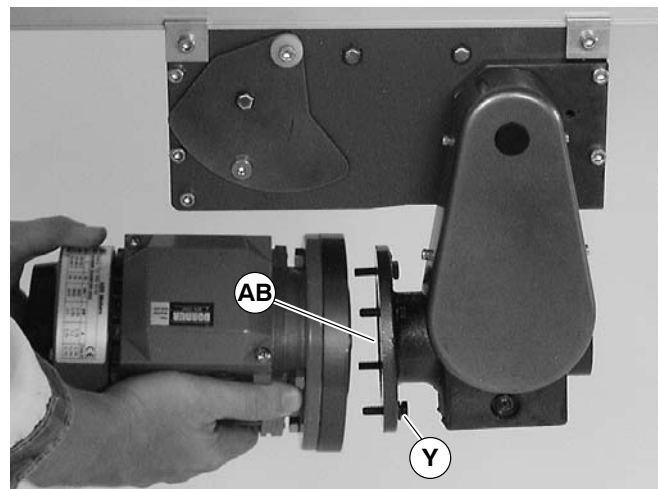

Figure 22

6. Replace wiring:

- For a single phase motor, reverse step 1 on this page.
- For a three phase motor, reverse step 2, on this page.
- For a DC variable speed motor, reverse step 3 on this page.

NOTE: For replacement parts other than those shown on this page, contact an authorized Dorner Service Center or the factory. Key Service Parts and Kits are identified by the Performance Parts Kits logo. Dorner recommends keeping these parts on hand.

Item	Part No.	Part Description
1	62MS411FN	Motor, 0.25hp (0.19Kw), 115/230 Volts, 60 Hz, 1-Phase
	62MS411FR	Motor, 0.25hp (0.19Kw), 115/230 Volts, 60 Hz, 1-Phase with Reversing
	62MS423	Motor, 0.25hp (0.19Kw), 208-230/460 Volts, 60 Hz, 3-Phase
	62MSD3DEN	Motor, 0.25hp (0.19Kw), 130 VDC
	62MH411FN	Motor, 0.5hp (0.37Kw), 115/230 Volts, 60Hz, 1-Phase
	62MH423	Motor, 0.5hp (0.37Kw) 208-230/460 Volts, 60Hz, 3 Phase
	62MHD9DEN	Motor, 0.5hp (0.37Kw), 90VDC
2	32MS423EN	Motor, 0.5hp (0.37Kw), 230 Volts, 3 Phase Inverter Duty
	32M005HL	Gear Reducer, 5:1, NEMA 42CZ
	32M010HL	Gear Reducer, 10:1, NEMA 42CZ
	32M020HL	Gear Reducer, 20:1, NEMA 42CZ
	32M040HL	Gear Reducer, 40:1, NEMA 42CZ
	32M060HL	Gear Reducer, 60:1, NEMA 42CZ
	32M005HS	Gear Reducer, 5:1, NEMA 56C
32M010HS	Gear Reducer, 10:1, NEMA 56C	
32M020HS	Gear Reducer, 20:1, NEMA 56C	
32M040HS	Gear Reducer, 40:1, NEMA 56C	
32M060HS	Gear Reducer, 60:1, NEMA 56C	
3	814-103	Timing Belt, 15mm W x 385mm L
	814-100	Timing Belt, 15mm W x 400mm L
	814-096	Timing Belt, 15mm W x 425mm L
	814-105	Timing Belt, 15mm W x 460mm L
4	802-046	Tensioner Bearing
5	450365MP	Driven Pulley, 19Tooth
	450366MP	Driven Pulley, 22Tooth
	450367MP	Driven Pulley, 28Tooth
	450368MP	Driven Pulley, 32Tooth
6	980422M	Square Key, 4 mm x 22 mm (2x)
7	450365MP	Drive Pulley, 19Tooth
	450366MP	Drive Pulley, 22Tooth
	450367MP	Drive Pulley, 28Tooth
	450368MP	Drive Pulley, 32Tooth
	450369MP	Drive Pulley, 44Tooth
	450370MP	Drive Pulley, 48Tooth
8	450444M	Gear Reducer Shaft
9	912-084	Key, Square, 0.188" x 1.5" L

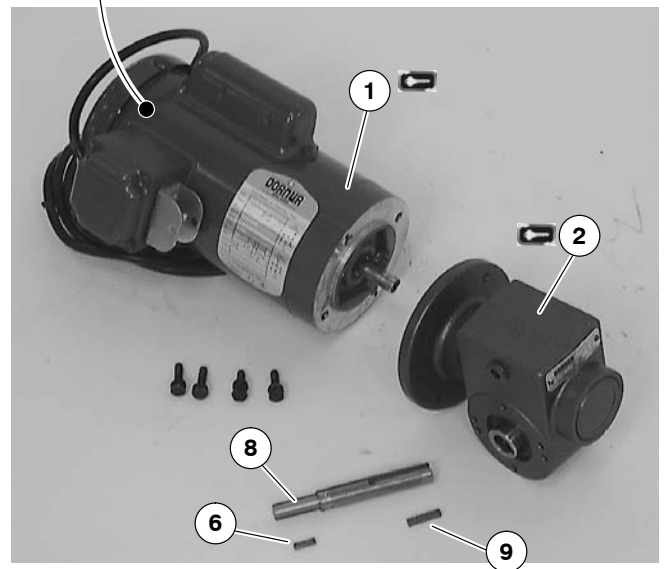
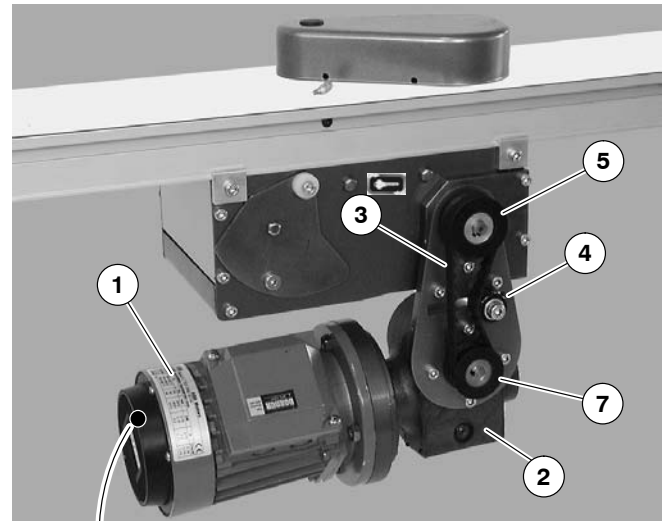

Figure 23

Return Policy

No returns will be accepted without prior written factory authorization. When calling for authorization, please have the following information ready for the Dorner Factory representative or your local distributor:

1. Name and address of customer.
2. Item(s) being returned.
3. Reason for return.
4. Customer's original order number used when ordering the item(s).
5. Dorner or distributor invoice number.

A representative will discuss action to be taken on the Returned items and provide a Returned Goods Authorization Number to reference.

There will be a 15% restocking charge on all new items returned for credit where Dorner was not at fault. These will not be accepted after 60 days from original invoice date. The restocking charge covers inspection, cleaning, disassembly, and reissuing to inventory.

If a replacement is needed prior to evaluation of returned item, a purchase order must be issued. Credit (if any) is issued only after return and evaluation is complete.

Dorner has representatives throughout the world. Feel free to contact Dorner for the name of your local representative. Our technical sales and service staff will gladly help with your questions on Dorner products.

For a copy of Dorner's Limited Warranty, contact factory, distributor, service center or visit our website @ www.dorner.com

DORNER[®]

Dorner Mfg. Corp. reserves the right to change or discontinue products without notice. All products and services are covered in accordance with our standard warranty. All rights reserved. © Dorner Mfg. Corp. 2000

DORNER MFG. CORP.

975 Cottonwood Ave. PO Box 20
Hartland, WI 53029-0020 USA
USA

TEL 1-800-397-8664 (USA)
FAX 1-800-369-2440 (USA)

Outside the USA:
TEL 1-262-367-7600, FAX 1-262-367-5827

DORNER

Arnold-Sommerfeld-Ring 2
D-52499 Baesweiler
Germany

TEL (02401) 80 52 90
FAX (02401) 80 52 93

Internet: www.dorner.com