

## **2100, 4100, 6100 Series Top Mount Drive Package for Standard Load 50 Hz Gearmotors**



## **Table of Contents**

Warnings – General Safety .....	2	Preventative Maintenance & Adjustment .....	7
Introduction .....	2	Required Tools .....	7
Product Description .....	3	Timing Belt Tensioning .....	7
Specifications .....	3	Timing Belt Replacement .....	7
Installation .....	5	Drive or Driven Pulley Replacement .....	7
Required Tools .....	5	Gear Reducer Replacement .....	8
Mounting .....	5	Motor Replacement .....	9
		Service Parts .....	11
		Return Policy .....	12

# Warnings – General Safety



	<b>WARNING</b>	
<p>The safety alert symbol, black triangle with white exclamation, is used to alert you to potential personal injury hazards.</p>		



		<b>WARNING</b>
<p>Gearmotors may be HOT. <b>DO NOT TOUCH</b> Gearmotors.</p>		

		<b>DANGER</b>
<p>Climbing, sitting, walking or riding on conveyor will cause severe injury. <b>KEEP OFF CONVEYORS.</b></p>		

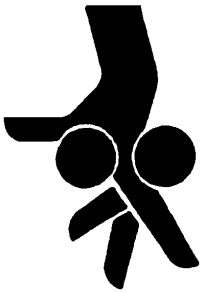
		<b>WARNING</b>
<p>Exposed moving parts can cause severe injury. <b>REPLACE ALL GUARDS BEFORE RUNNING CONVEYOR.</b></p>		

		<b>DANGER</b>
<p>Do NOT OPERATE CONVEYORS IN AN EXPLOSIVE ENVIRONMENT.</p>		

		<b>WARNING</b>
<p>Dorner cannot control the physical installation and application of conveyors. Taking protective measures is the responsibility of the user.</p> <p>When conveyors are used in conjunction with other equipment or as part of a multiple conveyor system, <b>CHECK FOR POTENTIAL PINCH POINTS</b> and other mechanical hazards before system start-up.</p>		

		<b>WARNING</b>
<p>Exposed moving parts can cause severe injury. <b>LOCK OUT POWER</b> before removing guards or performing maintenance.</p>		

## Introduction

**IMPORTANT:** Some illustrations may show guards removed. Do NOT operate equipment without guards.

Upon receipt of shipment:

- Compare shipment with packing slip. Contact factory regarding discrepancies.
- Inspect packages for shipping damage. Contact carrier regarding damage.
- Accessories may be shipped loose. See accessory instructions for installation.

Dorner 2100 Series conveyors are covered by the following patent numbers: 5131529, 5174435, and corresponding patents and patent applications in other countries.

Dorner 4100 Series conveyors are covered by patent number 3923148 and corresponding patents and patent applications in other countries.

Dorner 6100 Series conveyors are covered by patent number 5174435 and corresponding patents and patent applications in other countries.

Dorner's Limited Warranty applies.

Dorner reserves the right to make changes at any time without notice or obligation.

# Product Description

Refer to Figure 1 for typical components.

Typical Components	
A	Conveyor
B	Mounting Bracket
C	Gearmotor
D	Timing Belt Tensioner
E	Cover
F	Timing Belt
G	Drive Pulley
H	Driven Pulley

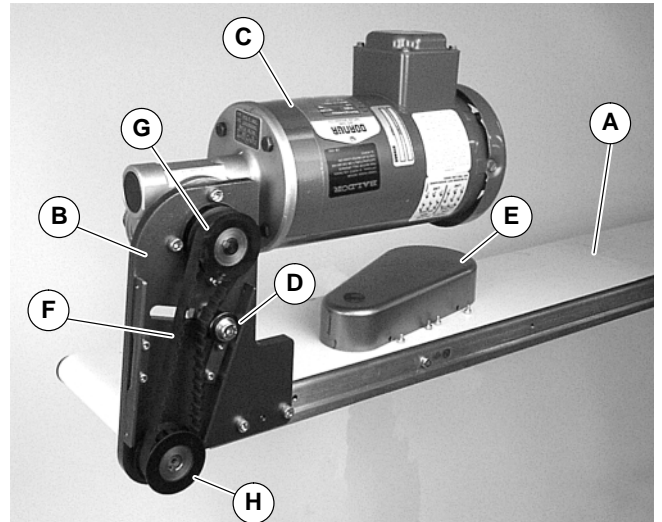

Figure 1

# Specifications

## Gearmotor Mounting Package Models:

Example:

**2 U T H S W W A - 32 32**  
 ————  
 ———— Driven Pulley (see Table 2 & 3)  
 ———— Drive Pulley (see Table 2 & 3)  
 ———— Belt Type ( - = flat belt, A through J = cleated belt )  
 ———— Mount Position = A, B, C or D  
 (see detail to the right)  
 ———— Conveyor Width Reference\*  
 ———— Gearmotor Type = Standard Load  
 ———— Output Shaft Type = 90°  
 ———— Mount Style = Top Mount  
 ———— Language Code = CE English  
 2 = 2100 Series Conveyor  
 4 = 4100 Series Conveyor  
 6 = 6100 Series Conveyor

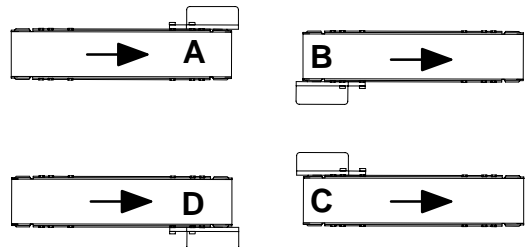

\* See "Ordering and Specifications" Catalog for details.

Table 1: Gearmotor Specifications

	Single Phase	Three Phase	VFD Variable Speed
Output Power	0.18 kw		
Input Voltage	230 Volts A.C.	230/400 Volts A.C.	230 Volts A.C.
Input Frequency	50 Hz		25 to 63 Hz
Input Current	1.6 Amperes	1.4/0.8 Amperes	1.4 Amperes
Gearmotor Ratios	5:1, 10:1, 20:1, 40:1, 60:1		
Protection Rating	IP55		
Frame Size	IEC 63 B5		

# Specifications

**Table 2: Belt Speeds for Standard Load Fixed Speed 90° 50 Hz Gearmotors**

Gearmotors			Belt Speed M/min	Drive Pulley	Driven Pulley
Part Number	RPM	N-m			
62Z060HS4(vp)FN	23	26.4	1.2	19	32
62Z060HS4(vp)FN	23	26.4	2.1	32	32
62Z040HS4(vp)FN	35	28.9	3.0	32	32
62Z040HS4(vp)FN	35	28.9	4.6	48	32
62Z020HS4(vp)FN	70	19.4	6.1	32	32
62Z020HS4(vp)FN	70	19.4	9.1	48	32
62Z010HS4(vp)FN	140	10.7	12.2	32	32
62Z010HS4(vp)FN	140	10.7	18.3	48	32
62Z005HS4(vp)FN	280	5.6	24.4	32	32
62Z005HS4(vp)FN	280	5.6	36.6	48	32
62Z005HS4(vp)FN	280	5.6	45.7	60	32
62Z005HS4(vp)FN	280	5.6	61.6	48	19
62Z005HS4(vp)FN	280	5.6	76.8	60	19

(vp) = voltage and phase  
 21 = 230 V, 1-phase  
 23 = 230 V, 3-phase  
 43 = 400 V, 3-phase

**Table 3: Belt Speeds for Standard Load Variable Speed 90° 50 Hz Gearmotors**

Gearmotors			Belt Speed M/min	Drive Pulley	Driven Pulley
Part Number	RPM	N-m			
62Z060HS423EN	23	26.4	0.6–1.5	19	32
62Z060HS423EN	23	26.4	1.0–2.6	32	32
62Z040HS423EN	35	28.9	1.5–3.8	32	32
62Z020HS423EN	70	19.4	3.0–7.7	32	32
62Z010HS423EN	140	10.7	6.1–15	32	32
62Z005HS423EN	280	5.6	1.2–30	32	32
62Z005HS423EN	280	5.6	23–57	60	32
62Z005HS423EN	280	5.6	31–78	48	19

**NOTE: For belt speed other than those listed, contact factory for details.**

## Required Tools

- Hex key wrenches:  
2 mm, 2.5 mm, 3 mm, 5 mm
- Straight edge
- Torque wrench

## Mounting

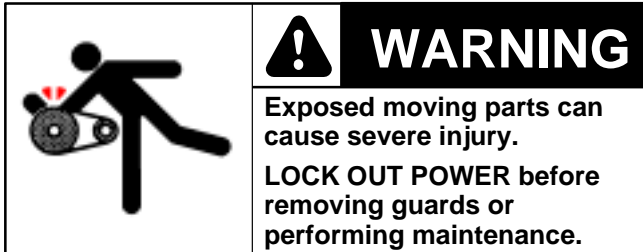

### Installation Component List

I	Top Mount Assembly
J	Drive Pulley
K	Cover
L	M4 Socket Head Screws (4x)
M	Driven Pulley
N	Key
O	M6 Socket Head Screws (2x)
P	Timing Belt

### 1. Typical components (Figure 2)

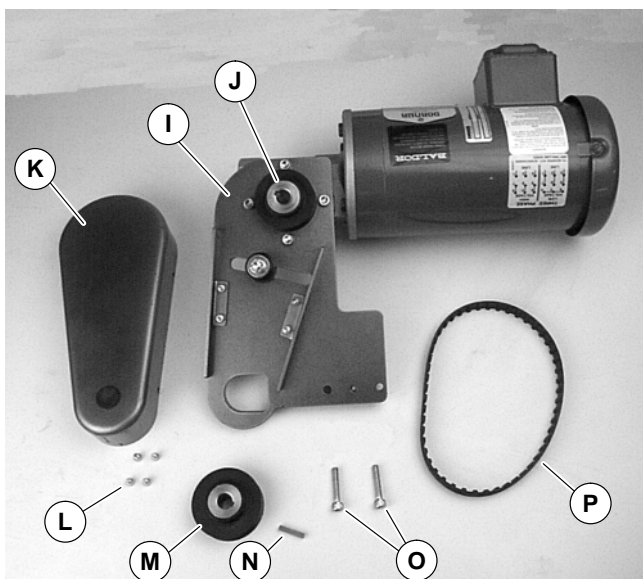

Figure 2

**NOTE:** Gearmotor may be operated in positions 1, 2 or 3 (Figure 3). Operating in position 2 may require additional support. Contact factory for details.

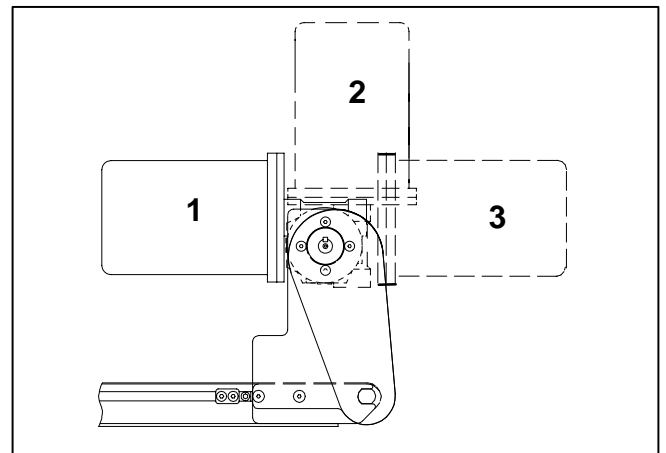

Figure 3

2. If required, change gearmotor position by removing four (4) screws (Q of Figure 4). Rotate gearmotor to other position and replace screws (Q). Tighten to 12 Nm.

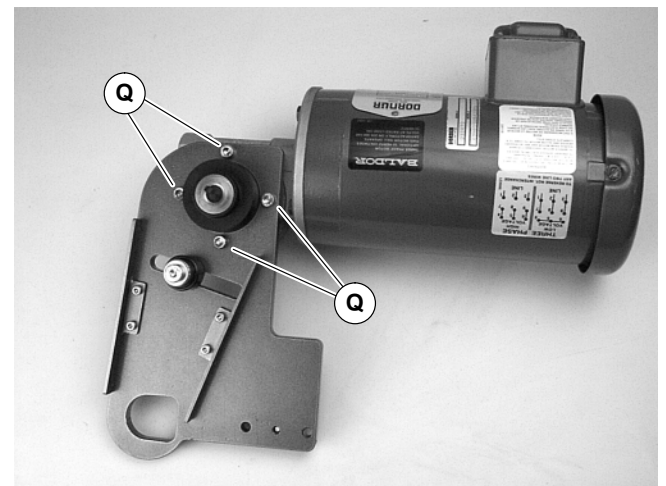

Figure 4

**NOTE:** 6100 conveyor shown, 2100 & 4100 similar.

3. Locate drive output shaft (R of Figure 5) and remove two (2) screws (S).

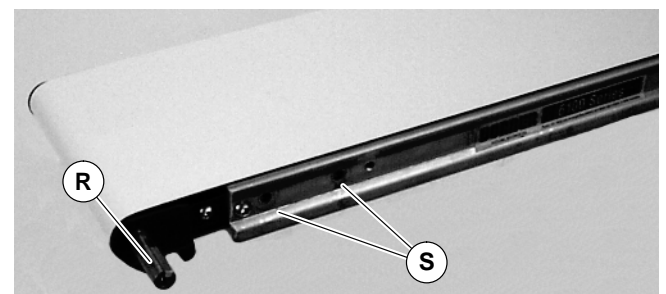

Figure 5

# Installation

4. Attach mount assembly (I of Figure 6) with screws (O). Tighten screws to 9 Nm.

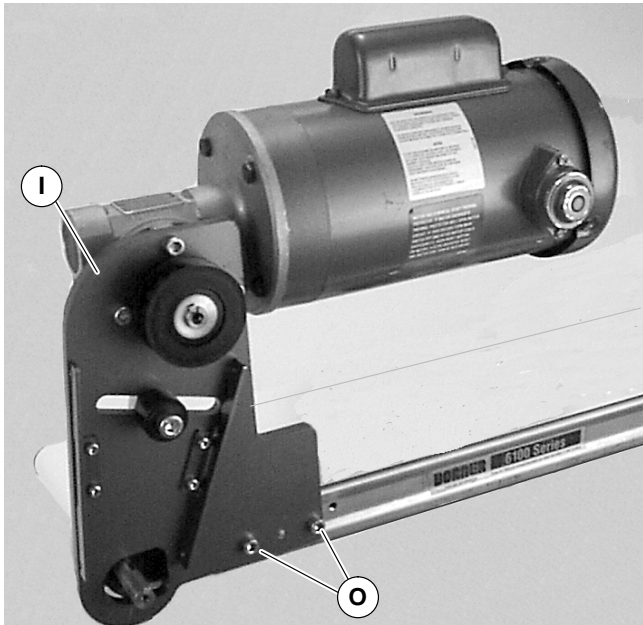

Figure 6

7. Using a straight edge (T of Figure 8), align driven pulley (M) with drive pulley (J). Tighten driven pulley set screws (U).

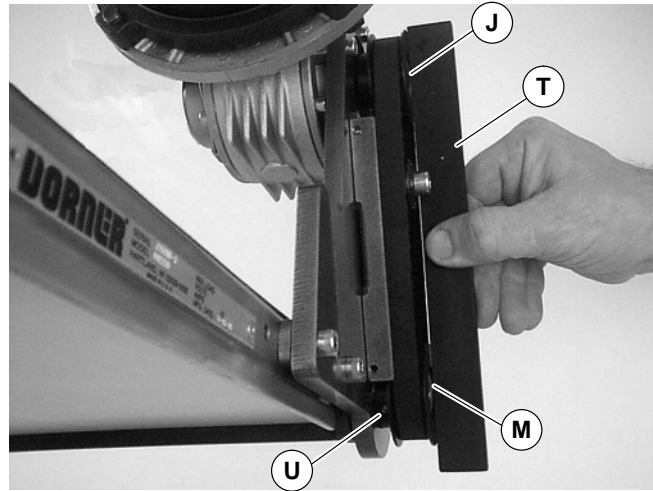

Figure 8

8. Depending on conveyor belt travel (direction 1 or 2), locate timing belt tensioner (V of Figure 9) as shown. Tension timing belt to obtain 3 mm deflection for 456 grams of force at timing belt mid-point (W). Tighten tensioner screw to 12 Nm.

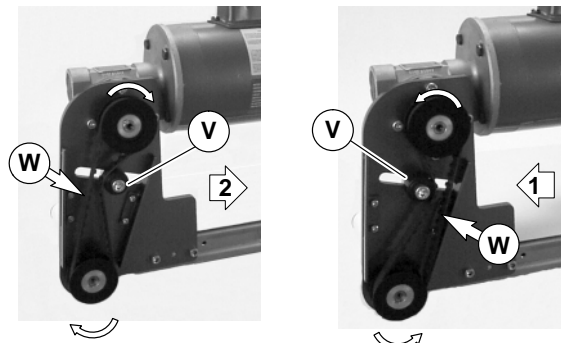

Figure 9

9. Install cover (K of Figure 10) with four (4) screws (L). Tighten screws to 4 Nm.

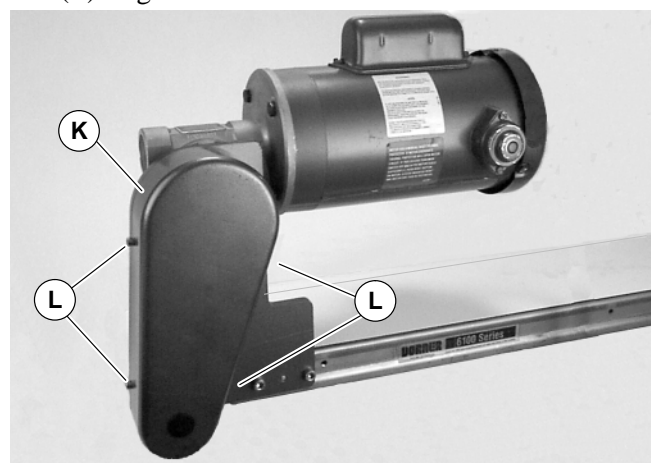

Figure 10

5. Install key (N of Figure 7).

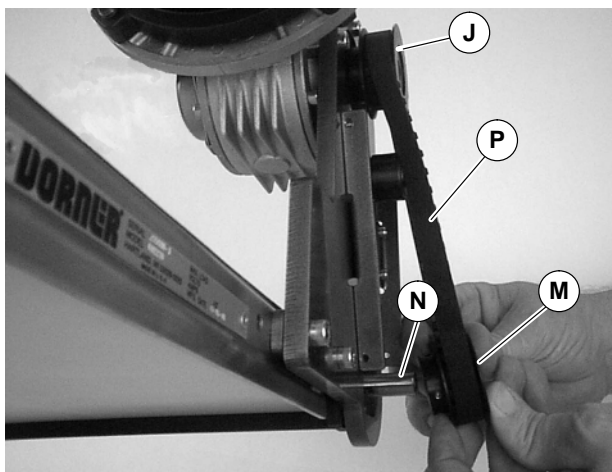

Figure 7

6. Wrap timing belt (P) around driven pulley (M) and drive pulley (J). Install driven pulley (M) onto conveyor shaft.



# Preventive Maintenance and Adjustment

## Required Tools

- Hex key wrenches
  - 2 mm, 2.5 mm, 3 mm & 5 mm
- Adjustable wrench (for hexagon head screws)
- Straight edge
- External snap ring pliers
- Torque wrench

## Timing Belt Tensioning



1. Remove four (4) screws (L of Figure 10) and remove cover (K).
2. Loosen tensioner (V of Figure 11).

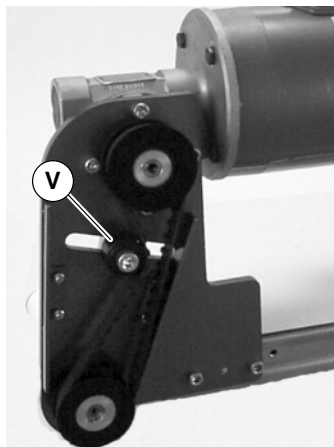
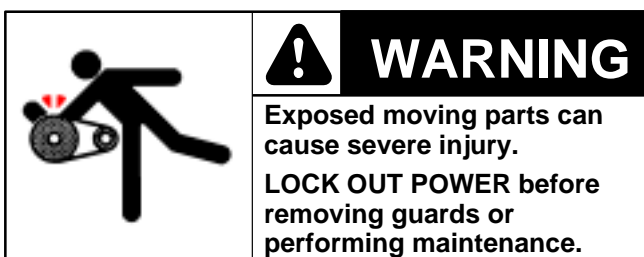

Figure 11

3. Depending on conveyor belt travel (direction 1 or 2), locate timing belt tensioner (V of Figure 9) as shown. Tension timing belt to obtain 3 mm deflection for 456 grams of force at timing belt mid-point (W). Tighten tensioner screw to 12 Nm.
4. Install cover (K of Figure 10) with four (4) screws (L). Tighten screws to 4 Nm.

## Timing Belt Replacement



1. Remove four (4) screws (L of Figure 10) and remove cover (K).
2. Loosen tensioner (V of Figure 11).
3. Remove timing belt (P of Figure 12).

**NOTE:** If timing belt does not slide over pulley flange, loosen driven pulley set screws (U of Figure 12) and remove pulley with belt (P). For re-installation, see steps 6 and 7 on page 6.

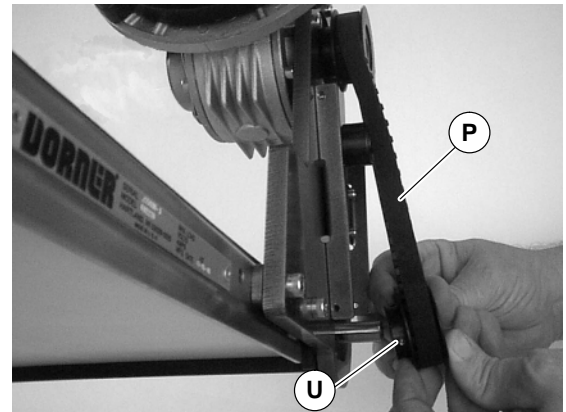
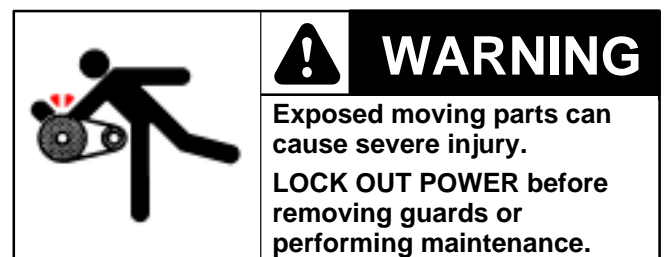

Figure 12

4. Install new timing belt.
5. Depending on conveyor belt travel (direction 1 or 2), locate timing belt tensioner (V of Figure 9) as shown. Tension timing belt to obtain 3 mm deflection for 456 grams of force at timing belt mid-point (W). Tighten tensioner screw to 12 Nm.
6. Install cover (K of Figure 10) with four (4) screws (L). Tighten screws to 4 Nm.

## Drive or Driven Pulley Replacement



1. Complete steps 1 through 3 of “Timing Belt Replacement” section on this page.
2. Loosen set screws and remove drive or driven pulley.

**NOTE:** If drive pulley (J of Figure 13) is replaced, wrap timing belt around drive pulley and complete step 3.

3. Complete steps 6 through 9 of “Installation” section on page 6.

# Preventive Maintenance and Adjustment

## Gear Reducer Replacement

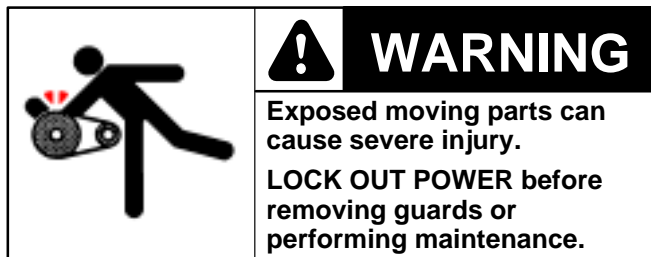

1. Remove four (4) screws (L of Figure 10) and remove cover (K).
2. Loosen tensioner (V of Figure 11).
3. Loosen drive pulley set screws (X of Figure 13). Remove drive pulley (J) and timing belt (P).

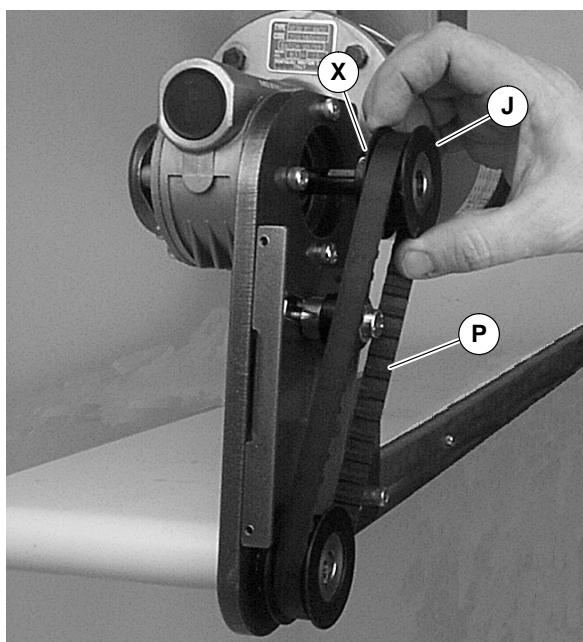

Figure 13

4. Remove four (4) gear reducer mounting screws (Q of Figure 14). Remove gearmotor.

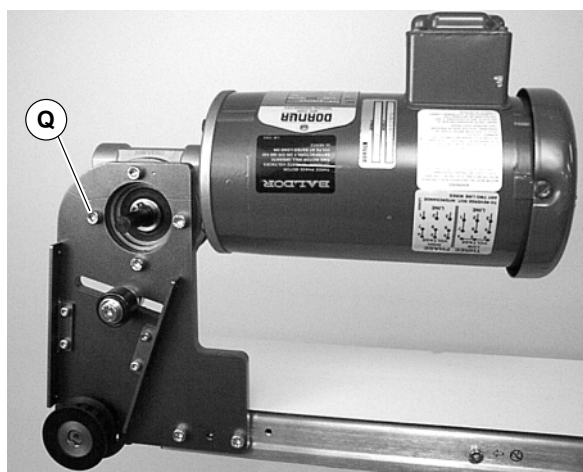

Figure 14

5. Remove four screws (Y of Figure 15). Detach motor with adapter flange (Z) from gear reducer (AA). Retain motor output shaft key (AB).

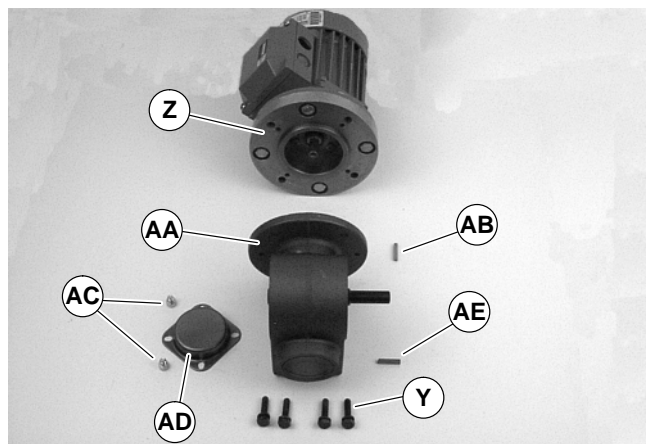

Figure 15

6. Remove two (2) screws (AC) and detach output shaft cover (AD).
7. Remove gear reducer output shaft key (AE).
8. Loosen six (6) set screws (AF of Figure 16). Remove drive shaft (AG) and key (AH).

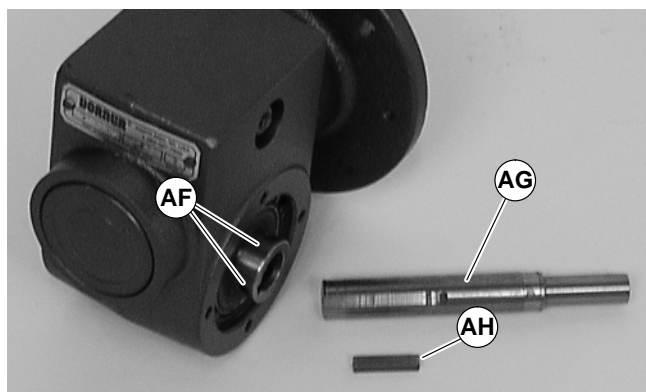

Figure 16

9. Apply grease (AI of Figure 17) to shaft.

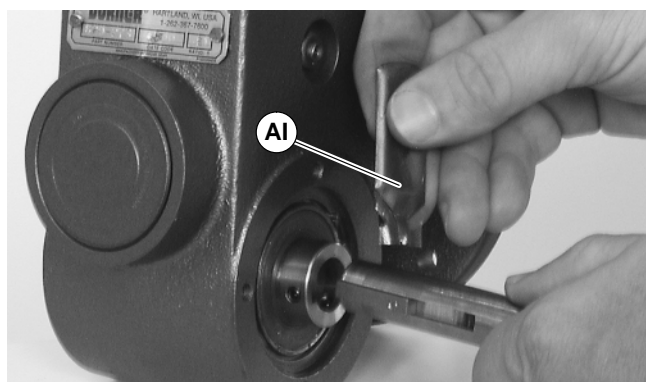

Figure 17



# Preventive Maintenance and Adjustment

10. Replace the original shaft (AG of Figure 16) and key (AH) into new gear reducer. Tighten set screws (AF) to 3 Nm.

**IMPORTANT:** Be extremely careful when coupling motor to gear reducer. Avoid misalignment and forcing the connection causing possible permanent gear reducer seal damage.

11. With key (AB of Figure 15) in keyway, slide motor with adapter flange (Z) and gear reducer (AA) together. Install screws (Y) and tighten.
12. Install gearmotor to mounting bracket and tighten screws (Q of Figure 14) to 12 Nm.

**NOTE:** Drive pulley (J of Figure 13) is removed. Wrap timing belt around drive pulley and complete step 13.

13. Complete steps 6 through 9 of “Installation” section on page 6.

## Motor Replacement



### WARNING

Exposed moving parts can cause severe injury. **LOCK OUT POWER** before removing guards or performing maintenance.



### DANGER

Hazardous voltage will cause severe injury or death. **LOCK OUT POWER BEFORE WIRING.**

1. For single phase motor:
  - a. Loosen terminal box screws (AJ of Figure 18) and remove cover (AK).

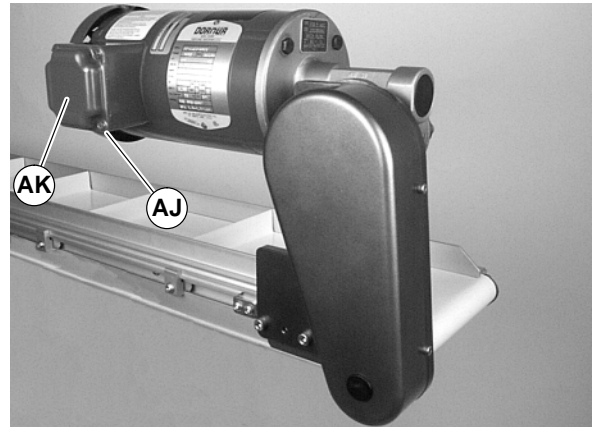

Figure 18

- b. Record wire colors on terminals 2, 6 and ground ( $\perp$ ) (Figure 19). Loosen terminals 2, 6 and ground and remove wires.

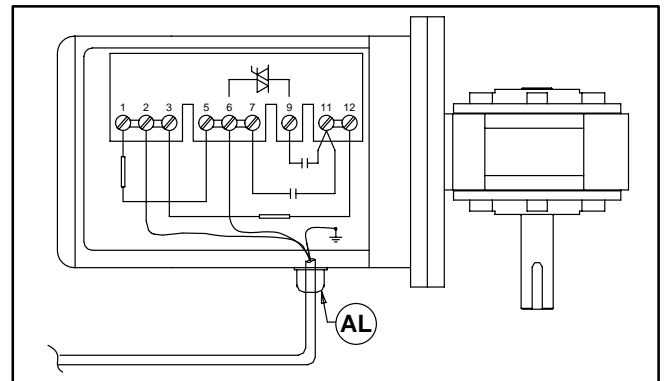

Figure 19

- c. Loosen cord grip (AL of Figure 19) and remove cord.

2. For three phase and VFD variable speed motor:

- a. Loosen terminal box screws (AJ of Figure 18) and remove cover (AK).
- b. Record wire colors on terminals U1, V1, W1 & PE (Figure 20). Loosen terminals U1, V1, W1 & PE and remove wires.

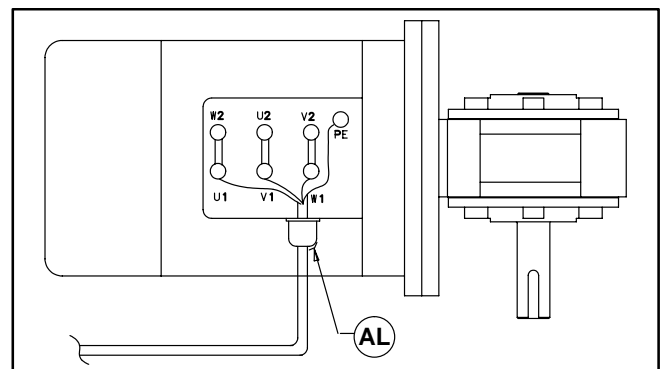

Figure 20

- c. Loosen cord grip (AL of Figure 20) and remove cord.

# Preventive Maintenance and Adjustment

3. Remove four (4) screws (Y of Figure 21). Detach motor (Z) with adapter flange from gear reducer (AA). Retain motor output shaft key (AB).

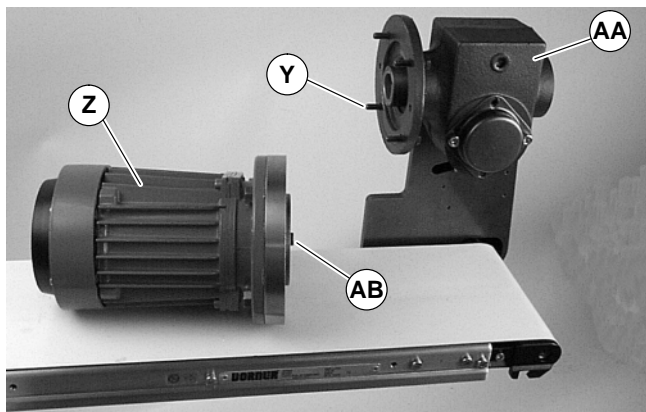

Figure 21

4. Remove four (4) screws and nuts (AM of Figure 22). Remove adapter flange (AN).

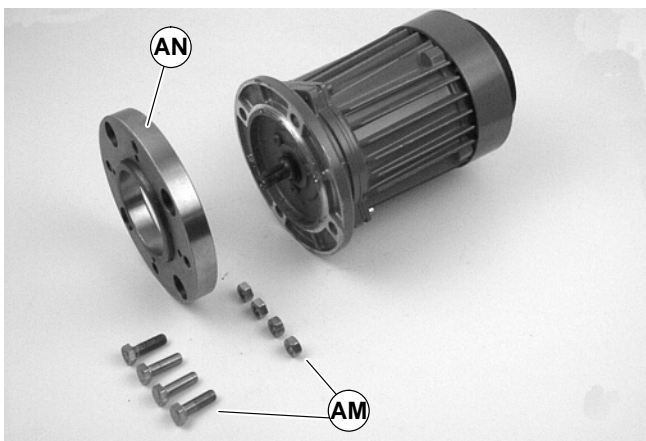

Figure 22

5. Install adapter flange (AN) on new motor. Install screws and nuts (AM) and tighten.

**IMPORTANT:** Be extremely careful when coupling motor to gear reducer. Avoid misalignment and forcing the connection causing possible permanent gear reducer seal damage.

6. With key (AB of Figure 23) in keyway, slide motor with adapter flange (Z) and gear reducer together. Install screws (Y) and tighten.

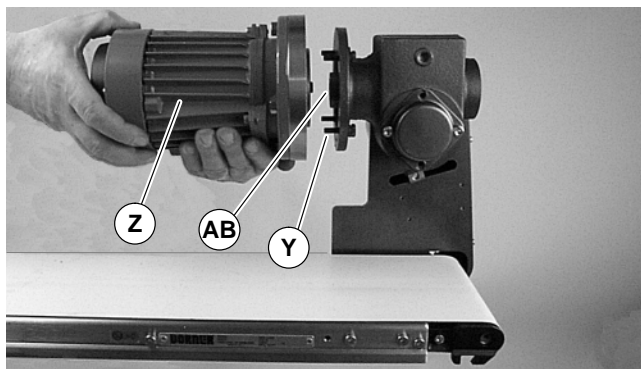

Figure 23

7. Replace wiring:

- For a single phase motor, reverse step 1 on page 9.
- For a three phase or VFD variable speed motor, reverse step 2 on page 9.

**NOTE:** For replacement parts other than those shown on this page, contact an authorized Dorner Service Center or the factory.

**NOTE:** For belt speed other than those listed, contact factory for details.

Item	Part No.	Part Description
1	826-281	Motor, 0.19 Kw 230 Volts, 1400 RPM 50 Hz, 1-Phase
	826-284	Motor, 0.19 Kw 230/400 Volts, 1400 RPM 50 Hz, 3-Phase
2	62Z005HS	Gear Reducer, 5:1, 63 B5
	62Z010HS	Gear Reducer, 10:1, 63 B5
	62Z020HS	Gear Reducer, 20:1, 63 B5
	62Z040HS	Gear Reducer, 40:1, 63 B5
	62Z060HS	Gear Reducer, 60:1, 63 B5
3	814-104	Timing Belt, 15mm W x 450mm L
	814-105	Timing Belt, 15mm W x 460mm L
	814-065	Timing Belt, 15mm W x 475mm L
	814-112	Timing Belt, 15mm W x 495mm L
	814-101	Timing Belt, 15mm W x 500mm L
	814-108	Timing Belt, 15mm W x 520mm L
	814-064	Timing Belt, 15mm W x 535mm L
	814-099	Timing Belt, 15mm W x 565mm L
4	802-046	Tensioner Bearing
5	450365MP	Driven Pulley, 19Tooth
	450366MP	Driven Pulley, 22Tooth
	450367MP	Driven Pulley, 28Tooth
	450368MP	Driven Pulley, 32Tooth
6	980422M	Square Key 4 mm x 22 mm (2x)
7	450365MP	Drive Pulley, 19Tooth
	450366MP	Drive Pulley, 22Tooth
	450367MP	Drive Pulley, 28Tooth
	450368MP	Drive Pulley, 32Tooth
	450369MP	Drive Pulley, 44Tooth
	450370MP	Drive Pulley, 48Tooth
	450371MP	Drive Pulley, 60Tooth
8	450444M	Gear Reducer Shaft
9	912-084	Key, Square, 0.188" x 1.5" L

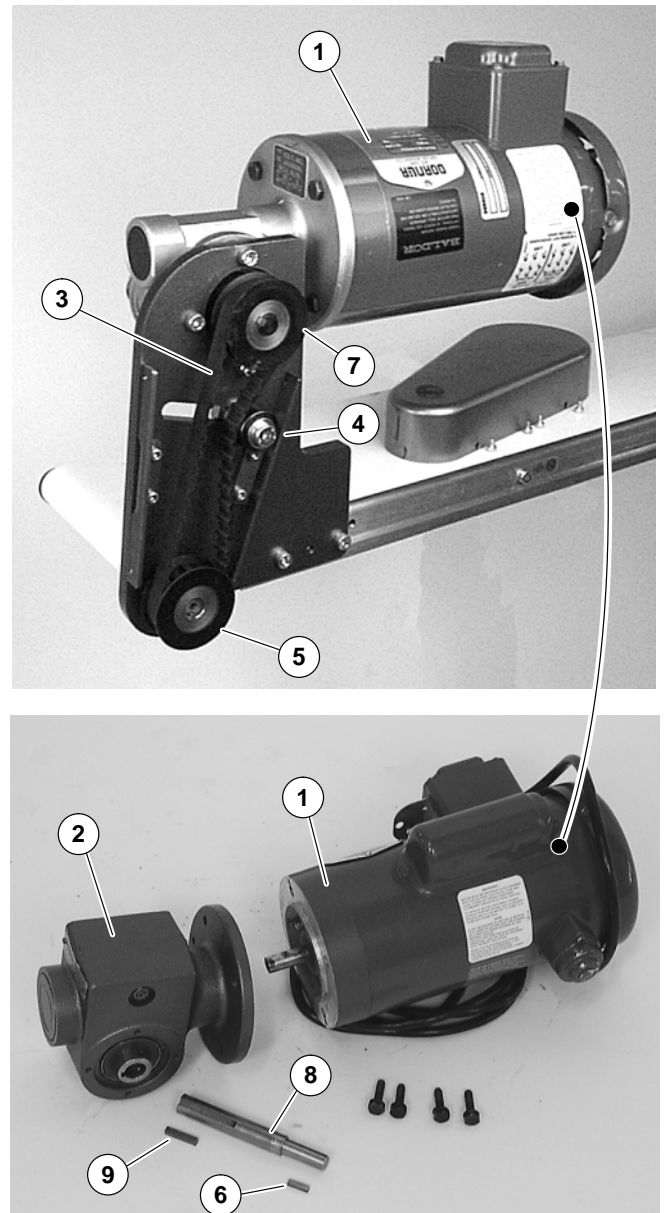

**Figure 24**

---

## Return Policy

---

No returns will be accepted without prior written factory authorization. When calling for authorization, please have the following information ready for the Dornier Factory representative or your local distributor:

1. Name and address of customer.
2. Item(s) being returned.
3. Reason for return.
4. Customer's original order number used when ordering the item(s).
5. Dornier or distributor invoice number.

A representative will discuss action to be taken on the Returned items and provide a Returned Goods Authorization Number to reference.

There will be a 15% restocking charge on all new items returned for credit where Dornier was not at fault. These will not be accepted after 60 days from original invoice date. The restocking charge covers inspection, cleaning, disassembly, and reissuing to inventory.

If a replacement is needed prior to evaluation of returned item, a purchase order must be issued. Credit (if any) is issued only after return and evaluation is complete.

Dornier has representatives throughout the world. Feel free to contact Dornier for the name of your local representative. Our technical sales and service staff will gladly help with your questions on Dornier products.

For a copy of Dornier's Limited Warranty, contact factory, distributor, service center or visit our website at [www.dornier.com](http://www.dornier.com)

**DORNER**<sup>®</sup>

Dornier Mfg. Corp. reserves the right to change or discontinue products without notice. All products and services are covered in accordance with our standard warranty. All rights reserved. © Dornier Mfg. Corp. 2000

**DORNER MFG. CORP.**

975 Cottonwood Ave. PO Box 20  
Hartland, WI 53029-0020 USA

USA  
TEL 1-800-397-8664 (USA)  
FAX 1-800-369-2440 (USA)

Outside the USA:  
TEL 1-262-367-7600, FAX 1-262-367-5827

**DORNER**

Arnold-Sommerfeld-Ring 2  
D-52499 Baesweiler

Germany  
TEL (02401) 80 52 90  
FAX (02401) 80 52 93

Internet: [www.dornier.com](http://www.dornier.com)