

2100, 4100, 6100 Series Bottom Mount Drive Package for Standard Load 50 Hz Gearmotors





Table of Contents

Warnings – General Safety	2	Preventative Maintenance & Adjustment	7
Introduction	2	Required Tools	7
Product Description	3	Timing Belt Tensioning	7
Specifications	3	Timing Belt Replacement	7
Installation	5	Drive or Driven Pulley Replacement	7
Required Tools	5	Gear Reducer Replacement	8
Mounting	5	Motor Replacement	9
		Service Parts	11
		Return Policy	12

Warnings – General Safety



	WARNING	
<p>The safety alert symbol, black triangle with white exclamation, is used to alert you to potential personal injury hazards.</p>		



	 WARNING
<p>Gearmotors may be HOT. DO NOT TOUCH Gearmotors.</p>	

	 DANGER
<p>Climbing, sitting, walking or riding on conveyor will cause severe injury. KEEP OFF CONVEYORS.</p>	

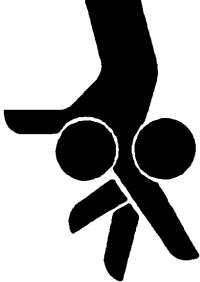
	 WARNING
<p>Exposed moving parts can cause severe injury. REPLACE ALL GUARDS BEFORE RUNNING CONVEYOR.</p>	

	 DANGER
<p>Do NOT OPERATE CONVEYORS IN AN EXPLOSIVE ENVIRONMENT.</p>	

	 WARNING
<p>Dorner cannot control the physical installation and application of conveyors. Taking protective measures is the responsibility of the user.</p> <p>When conveyors are used in conjunction with other equipment or as part of a multiple conveyor system, CHECK FOR POTENTIAL PINCH POINTS and other mechanical hazards before system start-up.</p>	

	 WARNING
<p>Exposed moving parts can cause severe injury. LOCK OUT POWER before removing guards or performing maintenance.</p>	

Introduction

IMPORTANT: Some illustrations may show guards removed. Do NOT operate equipment without guards.

Upon receipt of shipment:

- Compare shipment with packing slip. Contact factory regarding discrepancies.
- Inspect packages for shipping damage. Contact carrier regarding damage.
- Accessories may be shipped loose. See accessory instructions for installation.

Dorner 2100 Series conveyors are covered by the following patent numbers: 5131529, 5174435, and corresponding patents and patent applications in other countries.

Dorner 4100 Series conveyors are covered by patent number 3923148 and corresponding patents and patent applications in other countries.

Dorner 6100 Series conveyors are covered by patent number 5174435 and corresponding patents and patent applications in other countries.

Dorner's Limited Warranty applies.

Dorner reserves the right to make changes at any time without notice or obligation.

Product Description

Refer to Figure 1 for typical components.

Typical Components	
A	Conveyor
B	Mounting Bracket
C	Gearmotor
D	Timing Belt Tensioner
E	Cover
F	Timing Belt
G	Drive Pulley
H	Driven Pulley

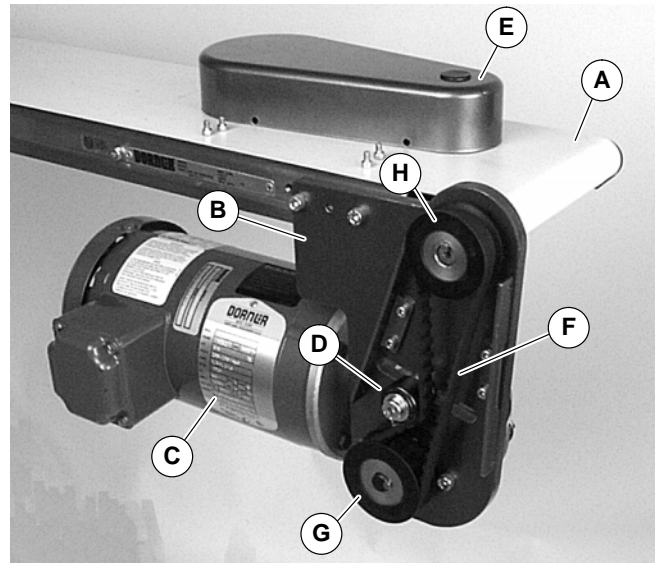

Figure 1

Specifications

Gearmotor Mounting Package Models:

Example:

2 U B H S WW A - 32 32

- 2 = 2100 Series Conveyor
- U = 4100 Series Conveyor
- B = 6100 Series Conveyor
- H = Output Shaft Type = 90°
- S = Mount Style = Bottom Mount
- WW = Language Code = CE English
- A = Mount Position = A, B, C or D (see detail to the right)
- = Belt Type (- = flat belt, A through J = cleated belt)
- 32 = Drive Pulley (see Table 2 & 3)
- 32 = Driven Pulley (see Table 2 & 3)

Conveyor Width Reference*

Gearmotor Type = Standard Load

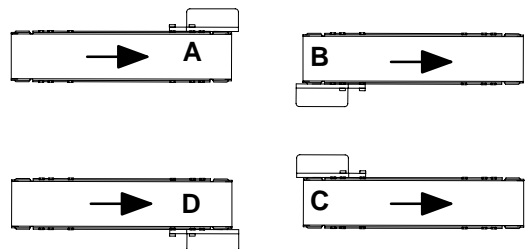

* See "Ordering and Specifications" Catalog for details.

Table 1: Gearmotor Specifications

	Single Phase	Three Phase	VFD Variable Speed
Output Power	0.18 kw		
Input Voltage	230 Volts A.C.	230/400 Volts A.C.	230 Volts A.C.
Input Frequency	50 Hz		25 to 63 Hz
Input Current	1.6 Amperes	1.4/0.8 Amperes	1.4 Amperes
Gearmotor Ratios	5:1, 10:1, 20:1, 40:1, 60:1		
Protection Rating	IP55		
Frame Size	IEC 63 B5		

Specifications

Table 2: Belt Speeds for Standard Load Fixed Speed 90° 50 Hz Gearmotors

Gearmotors			Belt Speed M/min	Drive Pulley	Driven Pulley
Part Number	RPM	N-m			
62Z060HS4(vp)FN	23	26.4	1.2	19	32
62Z060HS4(vp)FN	23	26.4	2.1	32	32
62Z040HS4(vp)FN	35	28.9	3.0	32	32
62Z040HS4(vp)FN	35	28.9	4.6	48	32
62Z020HS4(vp)FN	70	19.4	6.1	32	32
62Z020HS4(vp)FN	70	19.4	9.1	48	32
62Z010HS4(vp)FN	140	10.7	12.2	32	32
62Z010HS4(vp)FN	140	10.7	18.3	48	32
62Z005HS4(vp)FN	280	5.6	24.4	32	32
62Z005HS4(vp)FN	280	5.6	36.6	48	32
62Z005HS4(vp)FN	280	5.6	45.7	60	32
62Z005HS4(vp)FN	280	5.6	61.6	48	19
62Z005HS4(vp)FN	280	5.6	76.8	60	19

(vp) = voltage and phase
 21 = 230 V, 1-phase
 23 = 230 V, 3-phase
 43 = 400 V, 3-phase

Table 3: Belts Speeds for Standard Load Variable Speed 90° 50 Hz Gearmotors

Gearmotors			Belt Speed M/min	Drive Pulley	Driven Pulley
Part Number	RPM	N-m			
62Z060HS423EN	23	26.4	0.6–1.5	19	32
62Z060HS423EN	23	26.4	1.0–2.6	32	32
62Z040HS423EN	35	28.9	1.5–3.8	32	32
62Z020HS423EN	70	19.4	3.0–7.7	32	32
62Z010HS423EN	140	10.7	6.1–15	32	32
62Z005HS423EN	280	5.6	1.2–30	32	32
62Z005HS423EN	280	5.6	23–57	60	32
62Z005HS423EN	280	5.6	31–78	48	19

NOTE: For belt speed other than those listed, contact factory for details.

Required Tools

- Hex key wrenches:
2 mm, 2.5 mm, 3 mm, 5 mm
- Straight edge
- Torque wrench

Mounting

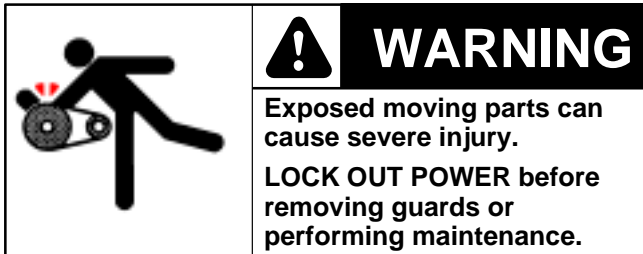

WARNING

Exposed moving parts can cause severe injury.

LOCK OUT POWER before removing guards or performing maintenance.

Installation Component List

I	Bottom Mount Assembly
J	Drive Pulley
K	Cover
L	M4 Socket Head Screws (4x)
M	Driven Pulley
N	Key
O	M6 Socket Head Screws (2x)
P	Timing Belt

NOTE: Gearmotor position on Flat Belt conveyor shown, left on Figure 2. Gearmotor position on Cleated Belt conveyor shown, right on Figure 2.

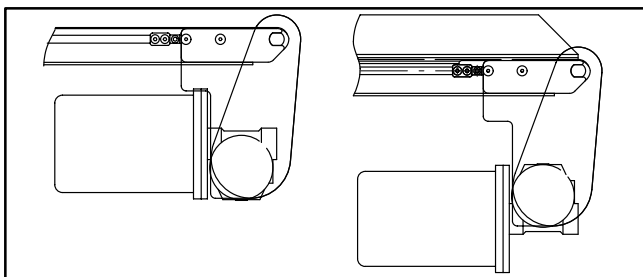

Figure 2

NOTE: Flat belt mounting package shown, cleated belt mounting package similar.

1. Typical components (Figure 3)

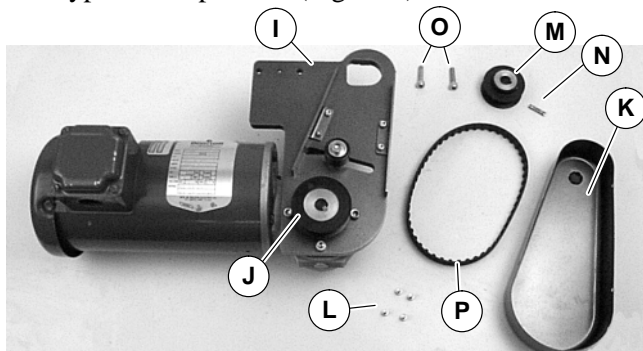

Figure 3

NOTE: Gearmotor may be operated in positions 1, 3 or 4 (Figure 4). Operating in position 4 may require additional support. Contact factory for details.

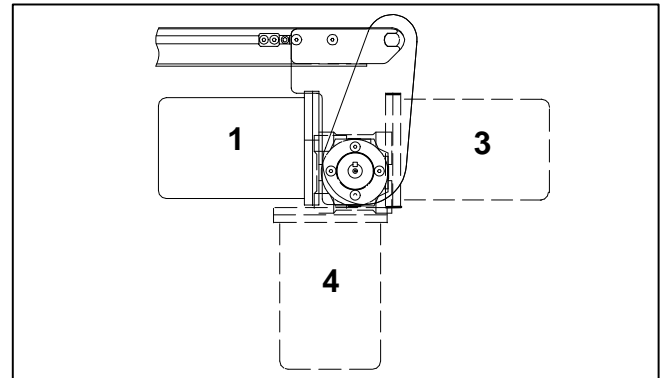

Figure 4

2. If required, change gearmotor position by removing four (4) screws (Q of Figure 5). Rotate gearmotor to other position and replace screws (Q). Tighten to 12 Nm.

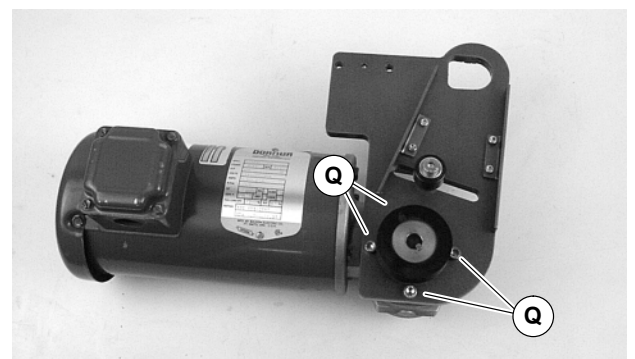

Figure 5

NOTE: 6100 conveyor shown, 2100 & 4100 similar.

3. Locate drive output shaft (R of Figure 6) and remove two (2) screws (S).

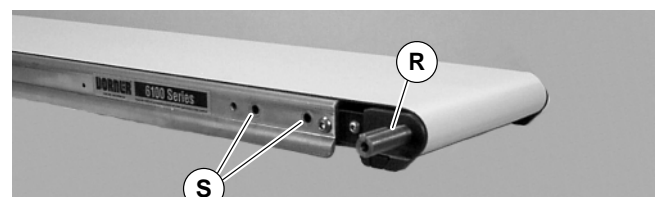

Figure 6

Installation

4. Attach mount assembly (I of Figure 7) with screws (O). Tighten screws to 9 Nm.

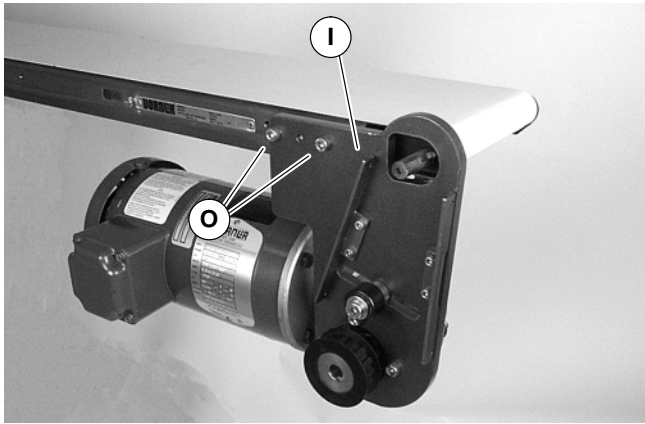

Figure 7

7. Using a straight edge (T of Figure 9), align driven pulley (M) with drive pulley (J). Tighten driven pulley set screws (U).

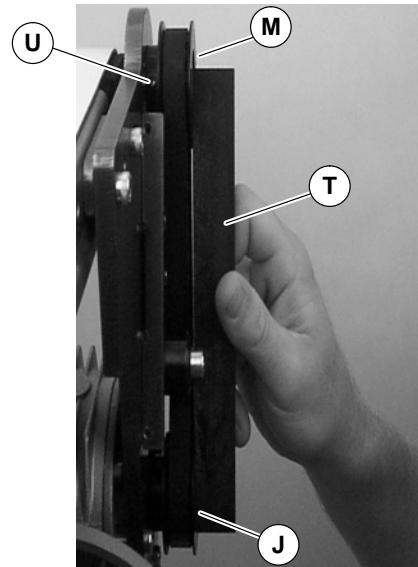

Figure 9



8. Depending on conveyor belt travel (direction 1 or 2), locate timing belt tensioner (V of Figure 10) as shown. Tension timing belt to obtain 3 mm deflection for 456 grams of force at timing belt mid-point (W). Tighten tensioner screw to 12 Nm.

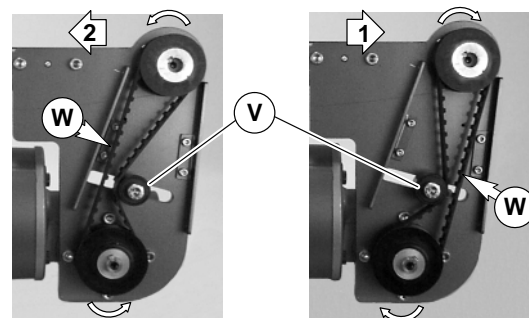

Figure 10

5. Install key (N of Figure 8).

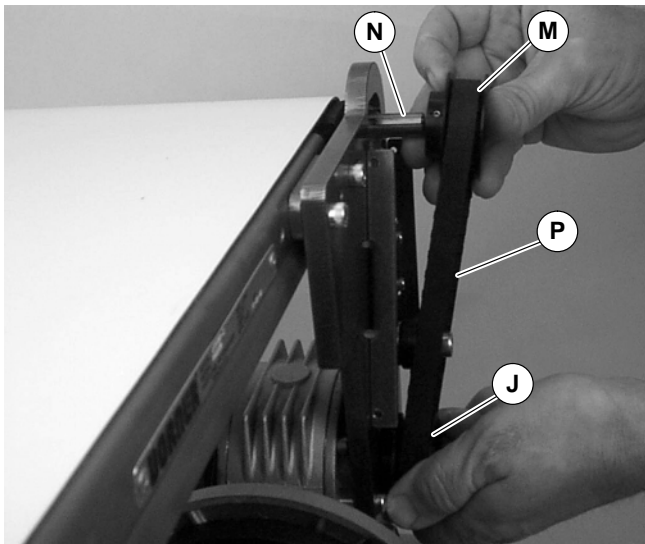

Figure 8

6. Wrap timing belt (P) around driven pulley (M) and drive pulley (J). Install driven pulley (M) onto conveyor shaft.

9. Install cover (K of Figure 11) with four (4) screws (L). Tighten screws to 4 Nm.

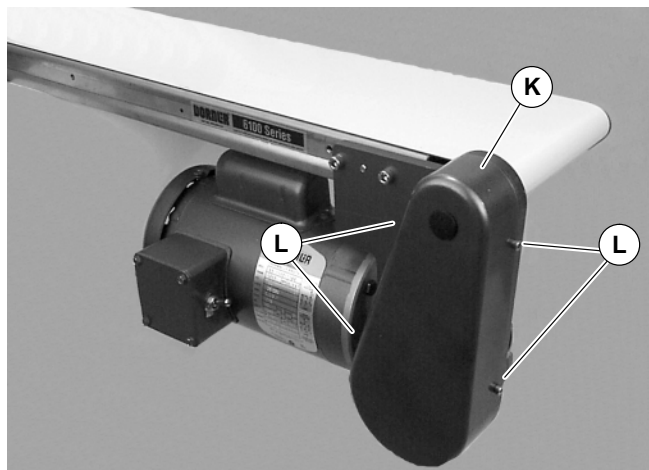

Figure 11

Preventive Maintenance and Adjustment

Required Tools

- Hex key wrenches:
 - 2 mm, 2.5 mm, 3 mm, 5 mm
- Adjustable wrench (for hexagon head screws)
- Straight edge
- External snap ring pliers
- Torque wrench

Timing Belt Tensioning

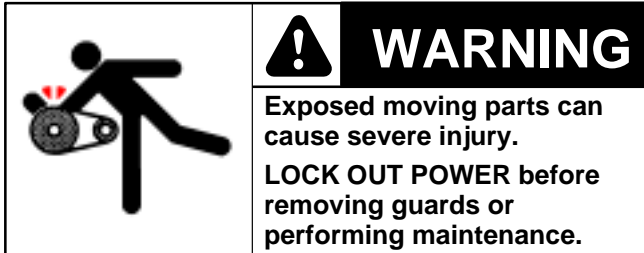

1. Remove four (4) screws (L of Figure 11) and remove cover (K).
2. Loosen tensioner (V of Figure 12).

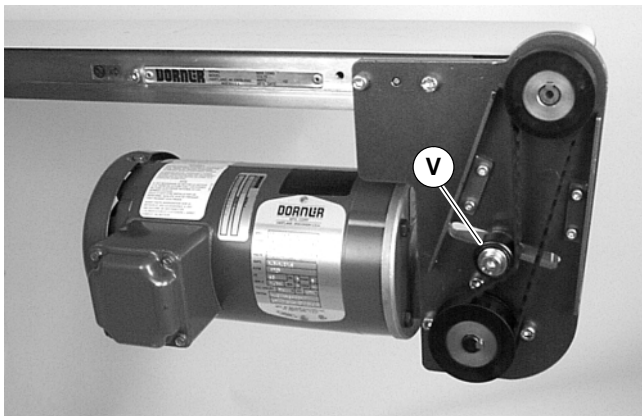

Figure 12

3. Depending on conveyor belt travel (direction 1 or 2), locate timing belt tensioner (V of Figure 10) as shown. Tension timing belt to obtain 3 mm deflection for 456 grams of force at timing belt mid-point (W). Tighten tensioner screw to 12 Nm.
4. Install cover (K of Figure 11) with four (4) screws (L). Tighten screws to 4 Nm.

Timing Belt Replacement



1. Remove four (4) screws (L of Figure 11) and remove cover (K).
2. Loosen tensioner (V of Figure 12).
3. Remove timing belt (P of Figure 13).

NOTE: If timing belt does not slide over pulley flange, loosen driven pulley set screws (U of Figure 13) and remove pulley with belt (P). For re-installation, see steps 6 and 7 on page 6.

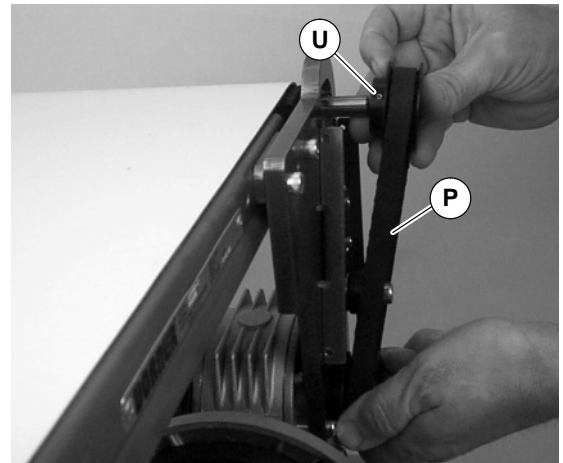
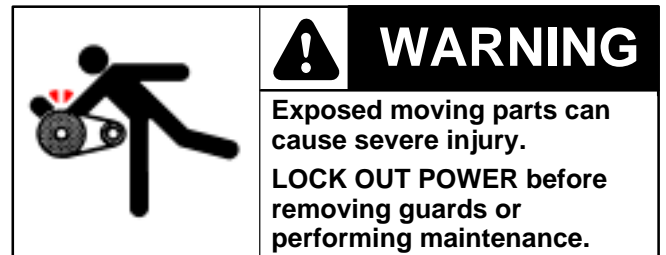

Figure 13

4. Install new timing belt.
5. Depending on conveyor belt travel (direction 1 or 2), locate timing belt tensioner (V of Figure 10) as shown. Tension timing belt to obtain 3 mm deflection for 456 grams of force at timing belt mid-point (W). Tighten tensioner screw to 12 Nm.
6. Install cover (K of Figure 11) with four (4) screws (L). Tighten screws to 4 Nm.

Drive or Driven Pulley Replacement



1. Complete steps 1 through 3 of “Timing Belt Replacement” section on this page.
2. Loosen set screws and remove drive or driven pulley.

NOTE: If drive pulley (J of Figure 14) is replaced, wrap timing belt around drive pulley and complete step 3.

3. Complete steps 6 through 9 of “Installation” section on page 6.

Preventive Maintenance and Adjustment

Gear Reducer Replacement

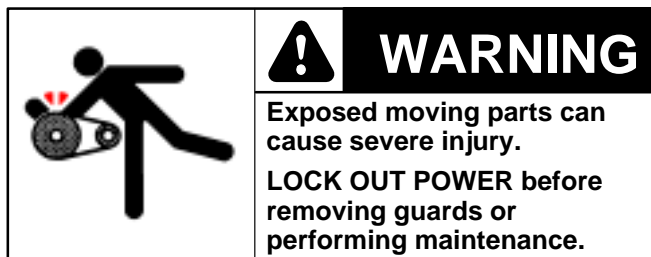

1. Remove four (4) screws (L of Figure 11) and remove cover (K).
2. Loosen tensioner (V of Figure 12).
3. Loosen drive pulley set screws (X of Figure 14). Remove drive pulley (J) and timing belt (P).

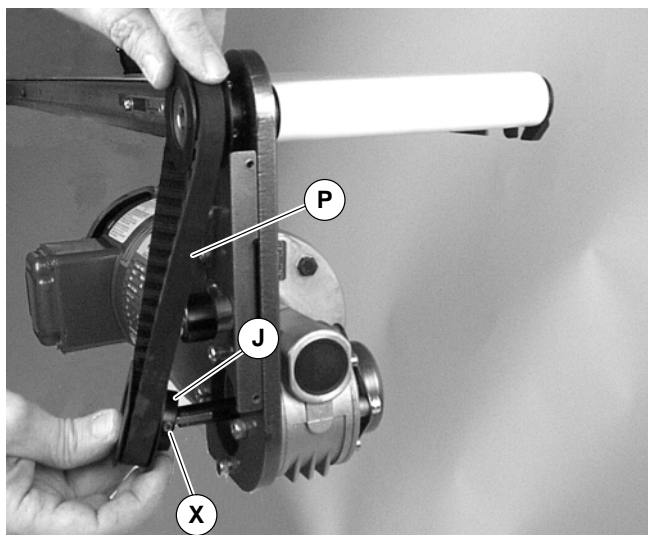

Figure 14

4. Remove four (4) gear reducer mounting screws (Q of Figure 15). Remove gearmotor.

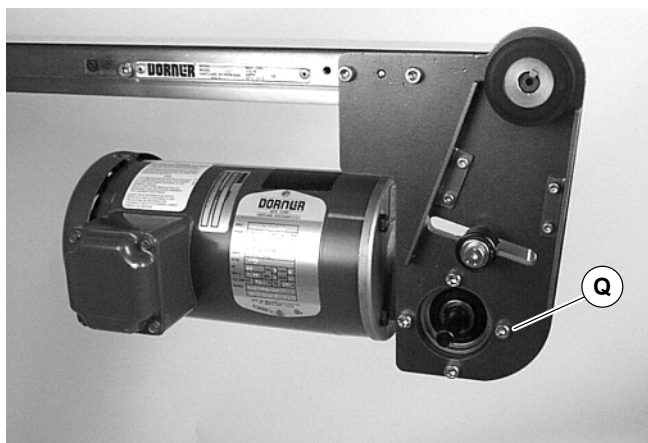

Figure 15

5. Remove four screws (Y of Figure 16). Detach motor with adapter flange (Z) from gear reducer (AA). Retain motor output shaft key (AB).

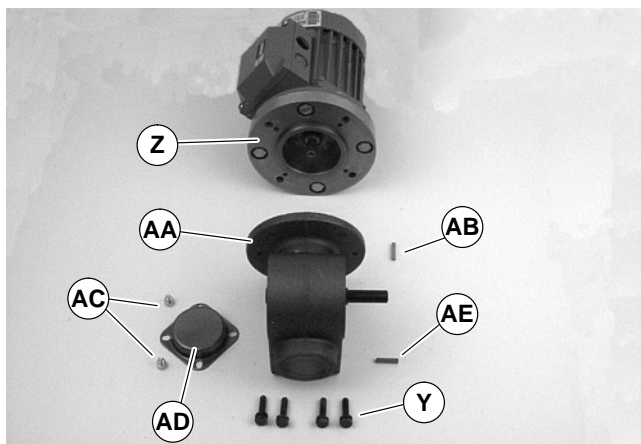

Figure 16

6. Remove two (2) screws (AC) and detach output shaft cover (AD).
7. Remove gear reducer output shaft key (AE).
8. Loosen six (6) set screws (AF of Figure 17). Remove drive shaft (AG) and key (AH).

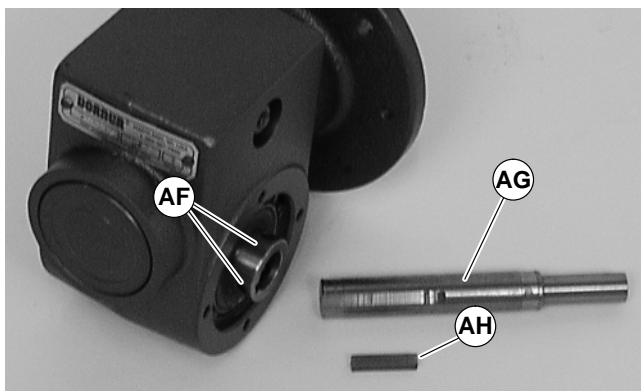

Figure 17

9. Apply grease (AI of Figure 18) to shaft.

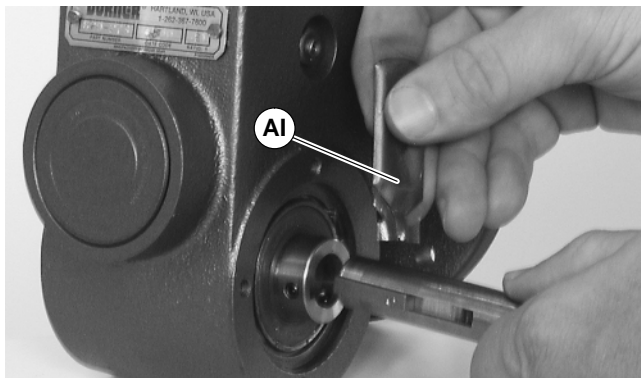

Figure 18

10. Replace the original shaft (AG of Figure 17) and key (AH) into new gear reducer. Tighten set screws (AF) to 3 Nm.

Preventive Maintenance and Adjustment

IMPORTANT: Be extremely careful when coupling motor to gear reducer. Avoid misalignment and forcing the connection causing possible permanent gear reducer seal damage.

- With key (AB of Figure 16) in keyway, slide motor with adapter flange (Z) and gear reducer (AA) together. Install screws (Y) and tighten.

NOTE: Gearmotor position on Flat Belt conveyor shown, left on Figure 19. Gearmotor position on Cleated Belt conveyor shown, right on Figure 19.

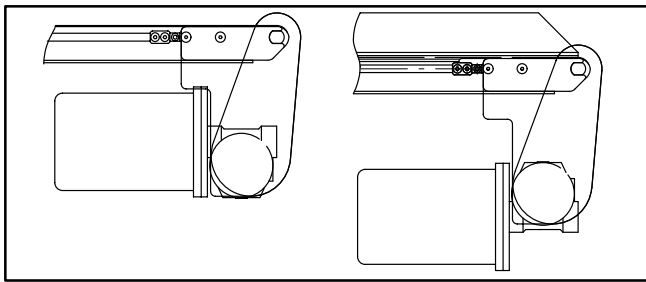

Figure 19

- Install gearmotor to mounting bracket and tighten screws (Q of Figure 15) to 12 Nm.

NOTE: Drive pulley (J of Figure 14) is removed. Wrap timing belt around drive pulley and complete step 13.

- Complete steps 6 through 9 of “Installation” section on page 6.

Motor Replacement

		<h3>WARNING</h3>
	<p>Exposed moving parts can cause severe injury. LOCK OUT POWER before removing guards or performing maintenance.</p>	

		<h3>DANGER</h3>
	<p>Hazardous voltage will cause severe injury or death. LOCK OUT POWER BEFORE WIRING.</p>	

- For single phase motor:

- Loosen terminal box screws (AJ of Figure 20) and remove cover (AK).



Figure 20

- Record wire colors on terminals 2, 6 and ground (\perp) (Figure 21). Loosen terminals 2, 6 and ground and remove wires.

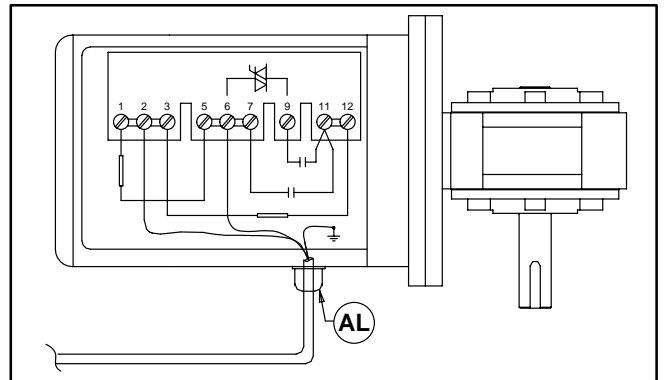

Figure 21

- Loosen cord grip (AL of Figure 21) and remove cord.

- For three phase and VFD variable speed motor:

- Loosen terminal box screws (AJ of Figure 20) and remove cover (AK).

- Record wire colors on terminals U1, V1, W1 & PE (Figure 22). Loosen terminals U1, V1, W1 & PE and remove wires.

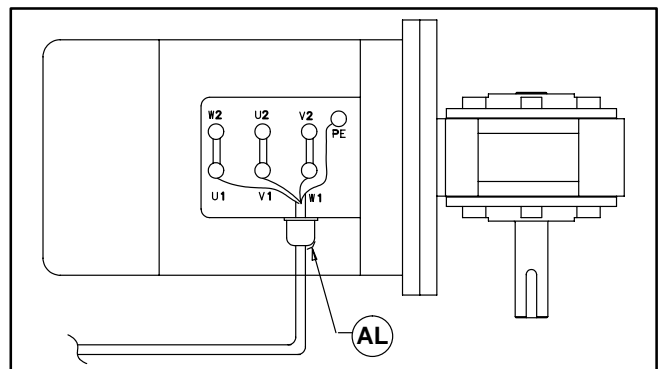

Figure 22

- Loosen cord grip (AL of Figure 22) and remove cord.

Preventive Maintenance and Adjustment

3. Remove four (4) screws (Y of Figure 23). Detach motor with adapter flange (Z) from gear reducer (AA). Retain motor output shaft key (AB).

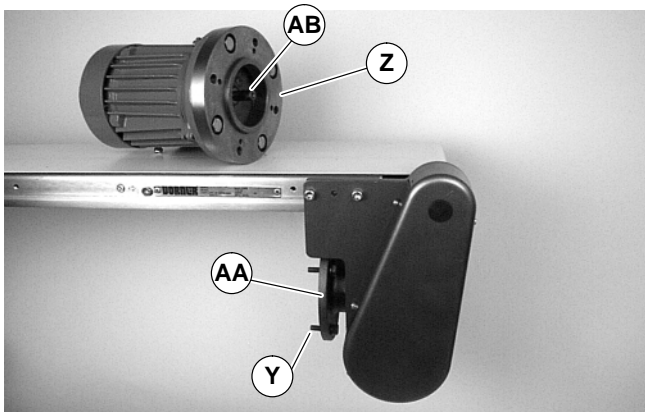

Figure 23

4. Remove four (4) screws and nuts (AM of Figure 24). Remove adapter flange (AN).

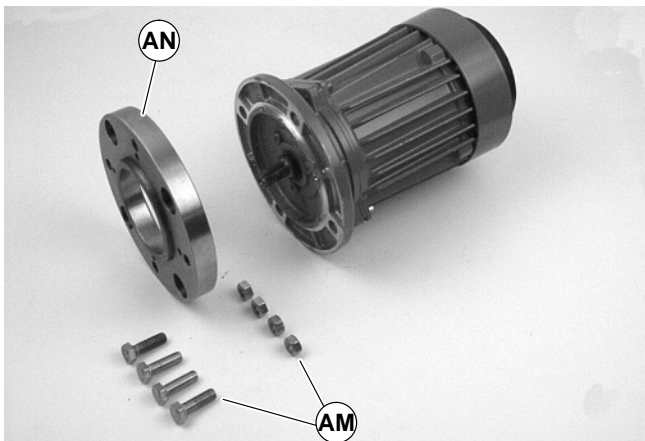

Figure 24

5. Install adapter flange (AN) on new motor. Install screws and nuts (AM) and tighten.

IMPORTANT: Be extremely careful when coupling motor to gear reducer. Avoid misalignment and forcing the connection causing possible permanent gear reducer seal damage.

6. With key (AB of Figure 25) in keyway, slide motor with adapter flange (Z) and gear reducer together. Install screws (Y) and tighten.

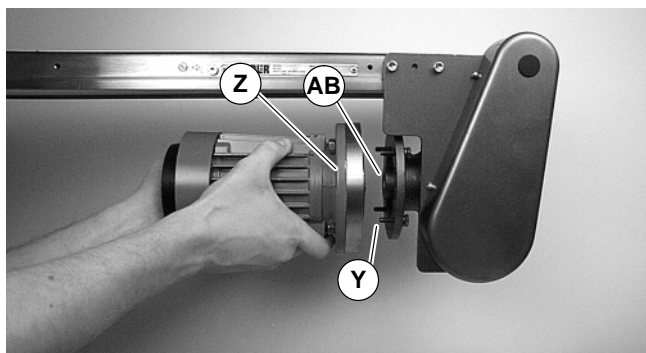

Figure 25

7. Replace wiring:

- For a single phase motor, reverse step 1 on page 9.
- For a three phase or VFD variable speed motor, reverse step 2 on page 9.

NOTE: For replacement parts other than those shown on this page, contact an authorized Dorner Service Center or the factory.

Item	Part No.	Part Description
1	826-281	Motor, 0.19 Kw 230 Volts, 1400 RPM 50 Hz, 1-Phase
	826-284	Motor, 0.19 Kw 230/400 Volts, 1400 RPM 50 Hz, 3-Phase
2	62Z005HS	Gear Reducer, 5:1, 63 B5
	62Z010HS	Gear Reducer, 10:1, 63 B5
	62Z020HS	Gear Reducer, 20:1, 63 B5
	62Z040HS	Gear Reducer, 40:1, 63 B5
	62Z060HS	Gear Reducer, 60:1, 63 B5
3	814-104	Timing Belt, 15mm W x 450mm L
	814-105	Timing Belt, 15mm W x 460mm L
	814-065	Timing Belt, 15mm W x 475mm L
	814-101	Timing Belt, 15mm W x 500mm L
	814-108	Timing Belt, 15mm W x 520mm L
	814-064	Timing Belt, 15mm W x 535mm L
	814-099	Timing Belt, 15mm W x 565mm L
4	802-046	Tensioner Bearing
5	450365MP	Driven Pulley, 19Tooth
	450366MP	Driven Pulley, 22Tooth
	450367MP	Driven Pulley, 28Tooth
	450368MP	Driven Pulley, 32Tooth
6	980422M	Square Key, 4 mm x 22 mm (2x)
7	450365MP	Drive Pulley, 19Tooth
	450366MP	Drive Pulley, 22Tooth
	450367MP	Drive Pulley, 28Tooth
	450368MP	Drive Pulley, 32Tooth
	450369MP	Drive Pulley, 44Tooth
	450370MP	Drive Pulley, 48Tooth
	450371MP	Drive Pulley, 60Tooth
8	450444M	Gear Reducer Shaft
9	912-084	Key, Square, 0.188" x 1.5" L

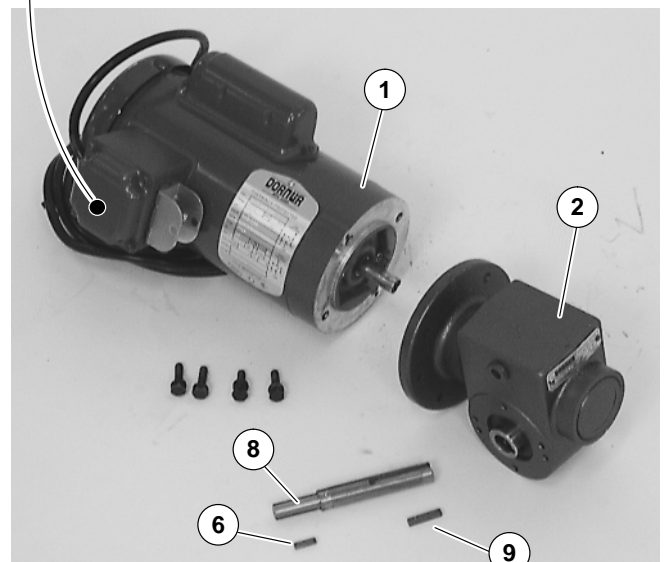
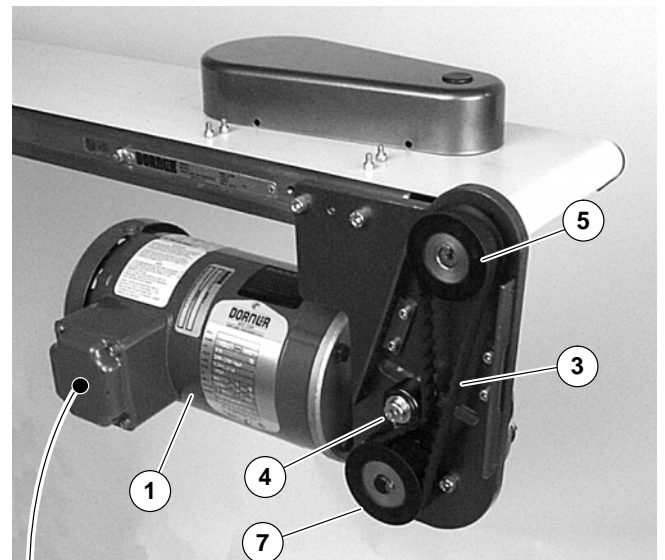

Figure 26

Return Policy

No returns will be accepted without prior written factory authorization. When calling for authorization, please have the following information ready for the Dorner Factory representative or your local distributor:

1. Name and address of customer.
2. Item(s) being returned.
3. Reason for return.
4. Customer's original order number used when ordering the item(s).
5. Dorner or distributor invoice number.

A representative will discuss action to be taken on the Returned items and provide a Returned Goods Authorization Number to reference.

There will be a 15% restocking charge on all new items returned for credit where Dorner was not at fault. These will not be accepted after 60 days from original invoice date. The restocking charge covers inspection, cleaning, disassembly, and reissuing to inventory.

If a replacement is needed prior to evaluation of returned item, a purchase order must be issued. Credit (if any) is issued only after return and evaluation is complete.

Dorner has representatives throughout the world. Feel free to contact Dorner for the name of your local representative. Our technical sales and service staff will gladly help with your questions on Dorner products.

For a copy of Dorner's Limited Warranty, contact factory, distributor, service center or visit our website at www.dorner.com

DORNER[®]

Dorner Mfg. Corp. reserves the right to change or discontinue products without notice. All products and services are covered in accordance with our standard warranty. All rights reserved. ©Dorner Mfg. Corp. 2000

DORNER MFG. CORP.

975 Cottonwood Ave. PO Box 20
Hartland, WI 53029-0020 USA

USA

TEL 1-800-397-8664 (USA)

FAX 1-800-369-2440 (USA)

Outside the USA:

TEL 1-262-367-7600, FAX 1-262-367-5827

DORNER

Arnold-Sommerfeld-Ring 2

D-52499 Baesweiler

Germany

TEL (02401) 80 52 90

FAX (02401) 80 52 93

Internet: www.dorner.com