

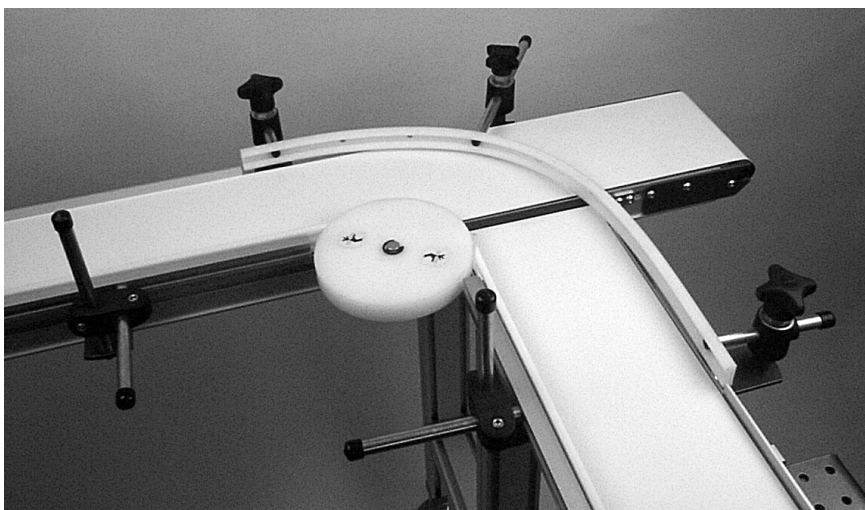

# 90° Adjustable Transfers for 2100 Series, 3100 Series & LPZ Conveyors

Set-up, Operation & Maintenance Manual



DORNER MFG. CORP.  
P.O. Box 20 • 975 Cottonwood Ave.  
Hartland, WI 53029-0020 USA

INSIDE THE USA  
TEL: 1-800-397-8664  
FAX: 1-800-369-2440

OUTSIDE THE USA  
TEL: 262-367-7600  
FAX: 262-367-5827

For other service manuals visit our website at:  
[www.dorner.com/service\\_manuals.asp](http://www.dorner.com/service_manuals.asp)

---

# Table of Contents

---

Introduction .....	2	Kit Mounting .....	4
Warnings - General Safety .....	3	Service Parts.....	7
Specifications .....	4	Return Policy.....	8
Installation .....	4		
Required Tools.....	4		

---

## Introduction

---

<b>IMPORTANT</b>
------------------

<i>Some illustrations may show guards removed. DO NOT operate equipment without guards.</i>
---

Upon receipt of shipment:

- Compare shipment with packing slip. Contact factory regarding discrepancies.
- Inspect packages for shipping damage. Contact carrier regarding damage.
- Accessories may be shipped loose. See accessory instructions for installation.

Dorner conveyors are covered by the following patent numbers: 5131529, 5156260, 5156261, 5174435, 5203447, 5265714, 5875883, and corresponding patents and patent applications in other countries.

Dorner's Limited Warranty applies.

Dorner reserves the right to make changes at any time without notice or obligation.

# Warnings - General Safety

## WARNING

The safety alert symbol, black triangle with white exclamation, is used to alert you to potential personal injury hazards.

## DANGER



Climbing, sitting, walking or riding on conveyor will cause severe injury.  
**KEEP OFF CONVEYORS.**

## DANGER



**DO NOT OPERATE CONVEYORS IN AN EXPLOSIVE ENVIRONMENT.**

## WARNING



Exposed moving parts can cause severe injury.  
**LOCK OUT POWER** before removing guards or performing maintenance.

## WARNING

A Transfer Plate and guiding **MUST** be installed on discharge end of Infeed Conveyor.

## WARNING



Loosening stand height or angle adjustment screws may cause conveyor sections to drop down, causing severe injury.  
**SUPPORT CONVEYOR SECTIONS PRIOR TO LOOSENING STAND HEIGHT OR ANGLE ADJUSTMENT SCREWS.**

## WARNING



Dorner cannot control the physical installation and application of conveyors. Taking protective measures is the responsibility of the user.

When conveyors are used in conjunction with other equipment or as part of a multiple conveyor system, **CHECK FOR POTENTIAL PINCH POINTS** and other mechanical hazards before system start-up.

## WARNING



Exposed moving parts can cause severe injury.  
**DO NOT ATTEMPT ADJUSTMENTS WITH CONVEYOR RUNNING.**

# Specifications

- Requires low side conveyors
- Maximum recommended part weight is 20 lb (9 Kg) at 50 ft/minute (15 M/minute) belt speed
- For conveyors up to 12" (610 mm) wide
- 1/4" (6 mm) minimum part thickness
- Minimum product size:
  - 3/4" (19 mm) for 2100 Series conveyor or 3100 Series conveyor with transfer tail option
  - 1-1/4" (32 mm) for 3100 Series or LPZ conveyors with standard 3" (76 mm) diameter tail

# Installation

**⚠ WARNING**



**Exposed moving parts can cause severe injury.**  
**LOCK OUT POWER** before removing guards or performing maintenance.

## Required Tools

- Hex key wrenches  
4 mm & 5 mm
- 17 mm wrench
- Torque wrench

## Kit Mounting

**⚠ WARNING**

**A Transfer Plate and guiding MUST be installed on discharge end of Infeed Conveyor.**

### Illustration References:

A	Infeed Conveyor
B	Transfer Plate
C	Outfeed Conveyor
D	Outside Turn Guide, 4-ft (1219 mm) Length
E	Guide Mounts with 4-1/2" (114 mm) Long Shaft (2x)
F	Guide Mounts with 12" (305 mm) Long Shaft (2x)
G	M6 x 12 mm Low Head Cap Screws (4x)
H	T-bars (5x)
I	M6 x 12 mm Socket Head Screws (10x)
J	Guide Wheel Assembly

1. Parts as shipped (Figure 1)

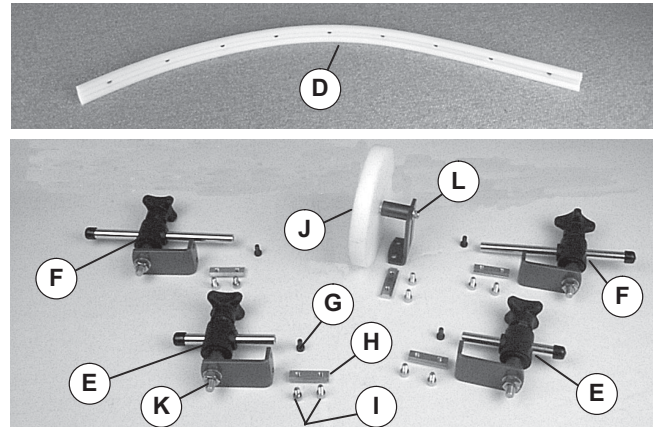

**Figure 1**

2. Identify infeed conveyor (Figure 2, item A) and outfeed conveyor (C). Install pulley transfer plate (B) on discharge end of infeed conveyor (A). See instructions in your Pulley Transfer Plates Set-up, Operation & Maintenance Manual.

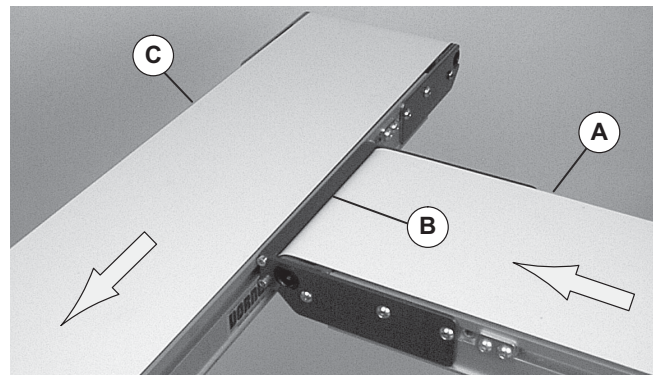

**Figure 2**

### NOTE

*The 90° Transfer Kit is a universal guide kit. The following is an example of a typical installation.*

# Installation

3. Install T-bars (Figure 3, item H) in both infeed conveyor (A) and outfeed conveyor (C) T-slots. See Figure 4 for attaching guide mounts.

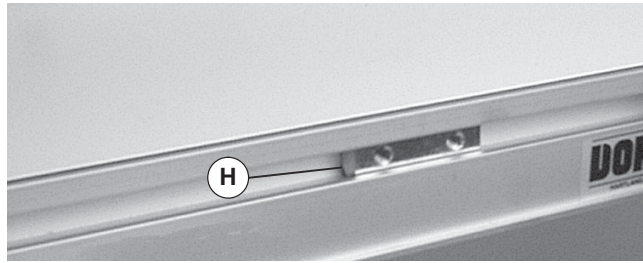

**Figure 3**

4. Loosely attach guide mounts with 4-1/2" (114 mm) long shafts (Figure 4, item E) to T-bars (Figure 1, item H) with screws (I).

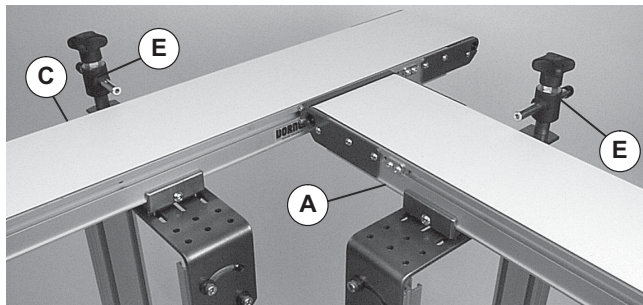

**Figure 4**

5. Attach outside turn guide (Figure 5, item D) to shaft of each guide mount (E) with screw (G). Tighten screws to 30 in-lb (3 Nm).

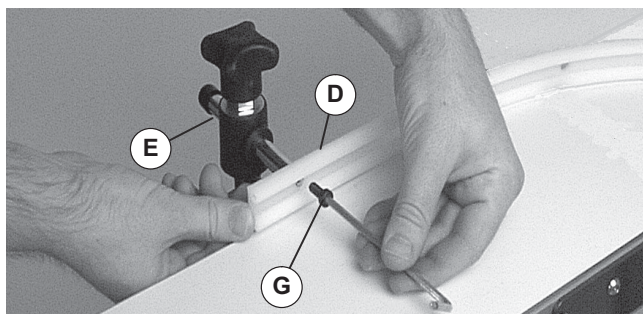

**Figure 5**

<b>⚠ WARNING</b>
<p><b>Exposed moving parts can cause severe injury.</b>  <b>DO NOT ATTEMPT ADJUSTMENTS WITH CONVEYOR RUNNING.</b></p>

6. Determine arc of guide (Figure 6, item D) and position of guide mounts (E). Adjust guide mounts to create desired guide position.

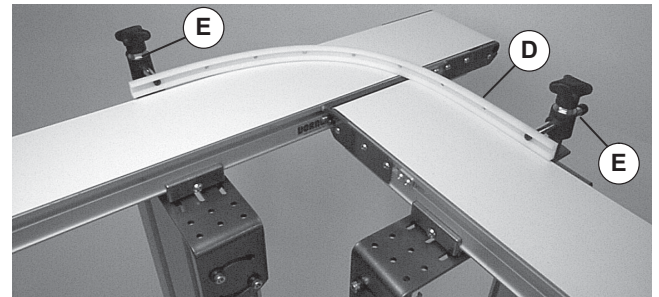

**Figure 6**

7. Secure fasteners:

- Tighten screws (Figure 1, item I) to 73 in-lb (8 Nm)
  - Tighten guide mount nuts (Figure 1, item K) to 146 in-lb (16 Nm)
8. To stabilize guide (Figure 7, item D), repeat steps 3 through 7 to install additional guide mount(s) (F), as required.

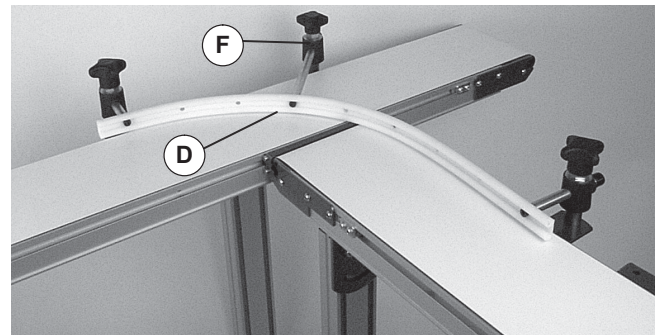

**Figure 7**

9. Trim excess guide (D) as required.
10. Install T-bar (Figure 8, item H) in T-slot of outfeed conveyor (C). Loosely attach guide wheel assembly (J) to T-bar with screws (I).

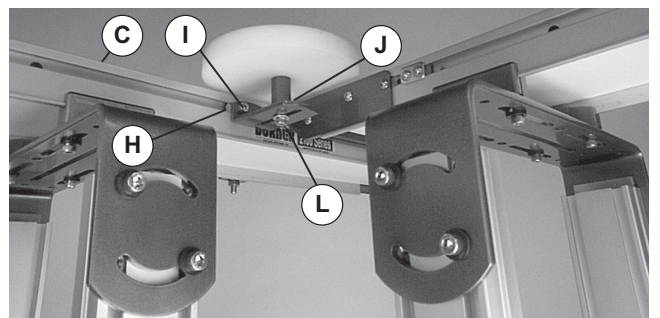

**Figure 8**

# Installation

## ⚠ WARNING



Exposed moving parts can cause severe injury.

**DO NOT ATTEMPT ADJUSTMENTS WITH CONVEYOR RUNNING.**

11. Adjust guide wheel assembly position, as required (Figure 8).
12. Secure fasteners:
  - Tighten screws (Figure 8, item I) to 73 in-lb (8 Nm)
  - Tighten screw (L) 146 in-lb (16 Nm)

## ⚠ WARNING

**Transfer Plate (Figure 1, item B) and guiding (M & N) MUST be installed on discharge end of Infeed Conveyor to eliminate pinch points.**

13. On the discharge end of the infeed conveyor (Figure 9, item A):
  - Install guiding (M) within 1/4" (6 mm) of the guide wheel assembly (J). See instructions provided with guiding.
  - Install guiding (N) against the outside turn guide (D). See instructions provided with guiding.

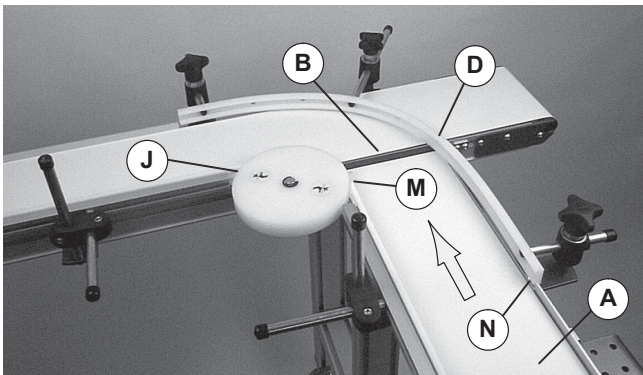
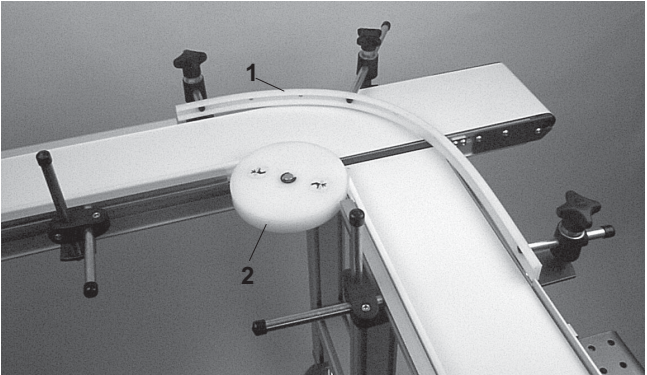

**Figure 9**

**NOTE**

*For replacement parts other than those shown on this page, contact an authorized Dorner Service Center or the factory.*

Item	Part No.	Part Description
1	234014	Guide, 4-ft (cut to length required)
2	234006	UHMW Guide Wheel



**Figure 10**

# Return Policy

Returns must have prior written factory authorization or they will not be accepted. Items that are returned to Dorner without authorization will not be credited nor returned to the original sender. When calling for authorization, please have the following information ready for the Dorner factory representative or your local distributor:

1. Name and address of customer.
2. Dorner part number(s) of item(s) being returned.
3. Reason for return.
4. Customer's original order number used when ordering the item(s).
5. Dorner or distributor invoice number.

A representative will discuss action to be taken on the returned items and provide a Returned Goods Authorization number for reference.

There will be a return charge on all new undamaged items returned for credit where Dorner was not at fault. Dorner is not responsible for return freight on such items.

Conveyors and conveyor accessories	
Standard catalog conveyors	30%
MPB Series, cleated and specialty belt conveyors	50%
7400 & 7600 Series conveyors	non-returnable items
Engineered special products	case by case
Drives and accessories	30%
Sanitary stand supports	non-returnable items

Parts	
Standard stock parts	30%
MPB, cleated and specialty belts	non-returnable items

Returns will not be accepted after 60 days from original invoice date.

The return charge covers inspection, cleaning, disassembly, disposal and reissuing of components to inventory.

If a replacement is needed prior to evaluation of returned item, a purchase order must be issued. Credit (if any) is issued only after return and evaluation is complete.

Dorner has representatives throughout the world. Contact Dorner for the name of your local representative. Our Technical Sales, Catalog Sales and Service Teams will gladly help with your questions on Dorner products.

For a copy of Dorner's Warranty, contact factory, distributor, service center or visit our website at [www.dorner.com](http://www.dorner.com).

For replacement parts, contact an authorized Dorner Service Center or the factory.



Dorner Mfg. Corp. reserves the right to change or discontinue products without notice. All products and services are covered in accordance with our standard warranty. All rights reserved. © Dorner Mfg. Corp. 2006

#### DORNER MFG. CORP.

975 Cottonwood Ave., PO Box 20  
Hartland, WI 53029-0020 USA  
USA  
TEL 1-800-397-8664 (USA)  
FAX 1-800-369-2440 (USA)  
Internet: [www.dorner.com](http://www.dorner.com)

Outside the USA:  
TEL 1-262-367-7600  
FAX 1-262-367-5827