

MPB Series End Drive Conveyors

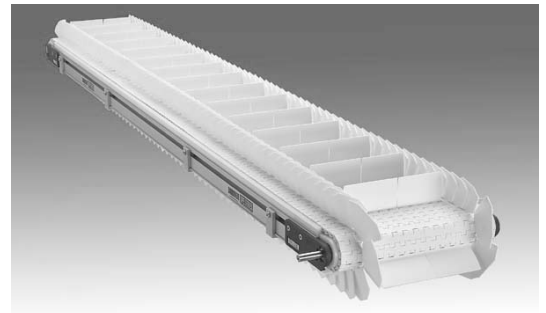
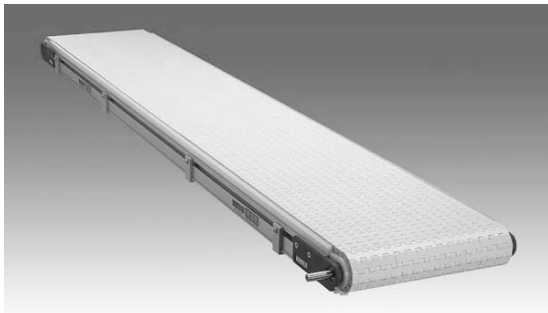
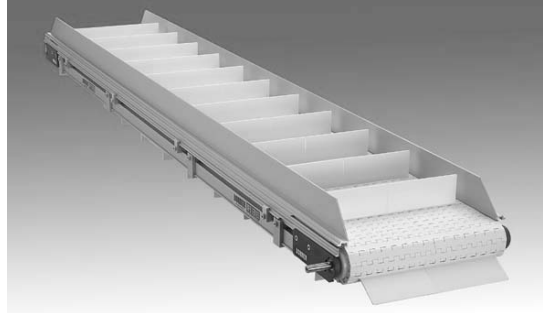





Table of Contents



Warnings – General Safety	2	Bearing Removal & Replacement	15
Introduction	2	Pulley Replacement	16
Product Description	3	Drive Pulley	16
Specifications	3	Idler Pulley	17
Load vs Speed vs Conveyor Length Per Width	5	Service Parts	20
Installation	6	4" (102mm) and 6" (152mm) Wide Conveyor Assembly	20
Required Tools	6	12" (305mm) Conveyor Assembly	22
Recommended Installation Sequence	6	18" (457mm) to 24" (610mm) Wide Conveyor Assembly .	26
Conveyors Up to 13 ft (3962 mm)	7	Return Wear Strip Assembly–Under 3' (914mm) Long	29
Conveyors Longer Than 13 ft (3962 mm)	7	Return Wear Strip Assembly–Over 3' (914mm) Long .	30
Mounting Brackets	7	–04 3" (76mm) Aluminum Side	31
Installing Plastic Belt	8	–05 1.5" (38mm) Aluminum Side	32
Preventative Maintenance & Adjustment	9	–13 Adjustable Guiding	34
Required Tools	9	2" (51mm) Cleated Guiding	35
Standard Tools	9	Flat Belt Mounting Bracket	36
Special Tools	9	Cleated Belt Mounting Bracket	36
Checklist	9	Flat Belt Mounting Brackets for 2' (610mm)	37
Lubrication	9	Conveyors	37
Maintaining Conveyor Belt	9	Cleated Belt Mounting Brackets for 2' (610mm)	37
Troubleshooting	9	Conveyors	37
Cleaning	9	Connecting Assembly without Stand Mount	38
Conveyor Belt Replacement	10	Flat Belt Connecting Assembly with Stand Mount	38
Conveyor Belt Replacement Sequence	10	Cleated Belt Connecting Assembly with Stand Mount .	39
Belt Removal	10	Conveyor Belting	40
Belt Installation	10	Complete Conveyor Belt	40
Conveyor Belt Tensioning	11	Belting Per 1ft (305mm)	40
Pulley Removal	13	Return Policy	42
A – Idler Pulley Removal	13		
B – Drive Pulley Removal	14		

Warnings – General Safety



	WARNING	
<p>The safety alert symbol, black triangle with white exclamation, is used to alert you to potential personal injury hazards.</p>		

		WARNING
<p>Gearmotors may be HOT. DO NOT TOUCH Gearmotors.</p>		

		DANGER
<p>Climbing, sitting, walking or riding on conveyor will cause severe injury. KEEP OFF CONVEYORS.</p>		

		WARNING
<p>Dorner cannot control the physical installation and application of conveyors. Taking protective measures is the responsibility of the user.</p> <p>When conveyors are used in conjunction with other equipment or as part of a multiple conveyor system, CHECK FOR POTENTIAL PINCH POINTS and other mechanical hazards before system start-up.</p>		

		DANGER
<p>DO NOT OPERATE CONVEYORS IN AN EXPLOSIVE ENVIRONMENT.</p>		

		WARNING
<p>Exposed moving parts can cause severe injury. LOCK OUT POWER before removing guards or performing maintenance.</p>		

		WARNING
<p>Loosening stand height or angle adjustment screws may cause conveyor sections to drop down, causing severe injury. SUPPORT CONVEYOR SECTIONS PRIOR TO LOOSENING STAND HEIGHT OR ANGLE ADJUSTMENT SCREWS.</p>		

Introduction

IMPORTANT: Some illustrations may show guards removed. **DO NOT** operate equipment without guards.

Upon receipt of shipment:

- ▮ Compare shipment with packing slip. Contact factory regarding discrepancies.
- ▮ Inspect packages for shipping damage. Contact carrier regarding damage.
- ▮ Accessories may be shipped loose. See accessory instructions for installation.

Dorner's Limited Warranty applies.

Dorner MPB & 2200 series conveyors are covered by Patent Numbers 5,174,435, 6,298,981 and corresponding patents and patent applications in other countries.

Dorner reserves the right to make changes at any time without notice or obligation.

Product Description

Refer to Figure 1 for typical conveyor components.

Typical Components	
A	Conveyor
B	Gearmotor Mounting Package
C	Gearmotor
D	Guiding & Accessories
E	Mounting Brackets
F	Support Stand
H	Drive End
I	Idler/Tension End

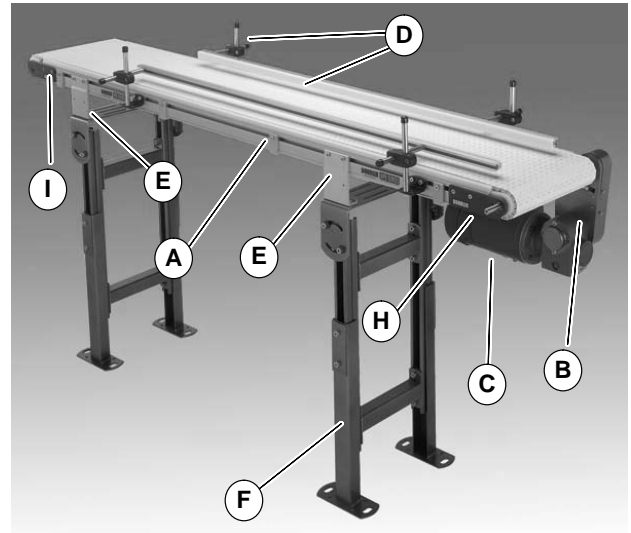

Figure 1

Specifications

Models:

Flat Belt MPB Series Conveyor

2	P	0	U	WW	LLLL	A	PP	BB	
									Belt Type*
									Conveyor Profile*
									Output Shaft Position*
									Conveyor Length Reference
									Conveyor Width Reference
									Document Language, U = CE English
									Stand Brackets: 0 = With required brackets 1 = Without required brackets
									Bedplate Style: C = Closed P = Perforated
									MPB Series Plastic Belt Conveyor

Cleated Belt MPB Series Conveyor

2	P	2	U	WW	LLLL	A	BB	SS	
									Cleat Spacing*
									Belt Type*
									Output Shaft Position*
									Conveyor Length Reference
									Conveyor Width Reference
									Document Language, U = CE English
									Stand Brackets: 2 = With required brackets 3 = Without required brackets
									Bedplate Style: C = Closed P = Perforated
									MPB Series Plastic Belt Conveyor

* See Ordering and Specifications Catalog for details.

Conveyor Supports:

Maximum Distances:

J = 18" (457 mm)**

K = 6 ft (1829 mm)***

L = 18" (457 mm)

** For Heavy Load Bottom Mount Package, mount support under gear head.

*** For conveyors longer than 13 ft (3962 mm), install support at joint.

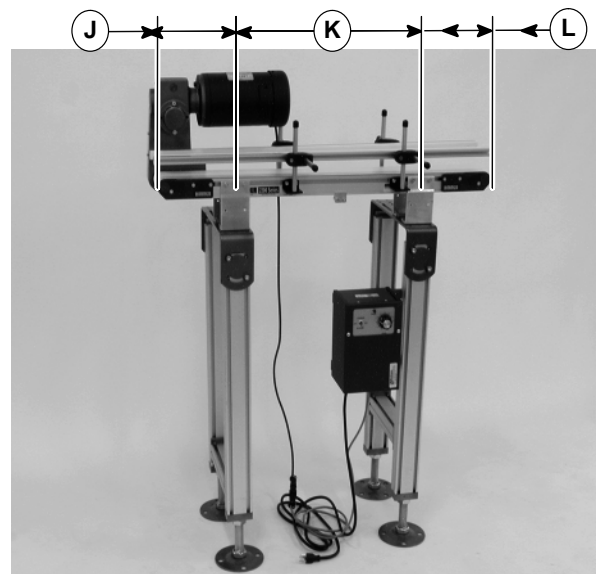

Figure 2

Specifications

Specifications:

Conveyor Width Reference (WW)	04	06	12	18	24
Conveyor Belt Width	3.0" (76mm)	5.25" (133mm)	11.25" (286mm)	17.25" (438mm)	23.25" (591mm)
Conveyor Length Reference (LL)	0200 to 3000 in 0002 increments				
Conveyor Length	2 ft (610mm) to 30 ft (9144mm) in 0.24" (6mm) increments				
Belt Travel	8.1" (209 mm) per revolution of pulley				
Maximum Belt Speed*	250 ft/minute (76.2 m/minute) for flat belt models 150 ft/minute (45.7 m/minute) for cleated belt models				
Belt Takeup	1.5" (38 mm) of stroke = 3" (76 mm) of belt take-up				

No Load Torque

NOTES:

1. No Load torques are for Flat Belt conveyors only. For No Load torques on Cleated and Sidewall Cleated Conveyors contact the factory.

2. The torque required to overcome the conveyor's

initial startup inertia may temporarily exceed the average "no load" torque by a factor of 2 to 3 times.

3. Stated torques are average values based on Dorner standard belts running at 50' (15meters) per minute.

Length (feet)	Width									
	3.0" (76mm)		5.25" (133mm)		11.25" (286mm)		17.25" (438mm)		23.25" (591mm)	
	in-lbs	N-m	in-lbs	N-m	in-lbs	N-m	in-lbs	N-m	in-lbs	N-m
2	5	0.6	6	0.6	6	0.7	7	0.8	7	0.8
3	5	0.6	6	0.7	7	0.8	8	0.9	8	1.0
4	6	0.6	6	0.7	7	0.8	8	1.0	10	1.1
5	6	0.7	6	0.7	8	0.9	9	1.0	11	1.2
6	6	0.7	7	0.7	8	0.9	10	1.1	12	1.3
7	6	0.7	7	0.8	9	1.0	11	1.2	13	1.5
8	6	0.7	7	0.8	9	1.1	12	1.3	14	1.6
9	6	0.7	7	0.8	10	1.1	13	1.4	15	1.7
10	7	0.7	8	0.9	11	1.2	14	1.5	16	1.9
11	7	0.8	8	0.9	11	1.3	14	1.6	18	2.0
12	7	0.8	8	0.9	12	1.3	15	1.7	19	2.1
13	7	0.8	8	0.9	12	1.4	16	1.8	20	2.3
14	7	0.8	9	1.0	13	1.4	17	1.9	21	2.4
15	7	0.8	9	1.0	13	1.5	18	2.0	22	2.5
16	8	0.9	9	1.0	14	1.6	19	2.1	23	2.6
17	8	0.9	9	1.1	14	1.6	19	2.2	25	2.8
18	8	0.9	10	1.1	15	1.7	20	2.3	26	2.9
19	8	0.9	10	1.1	16	1.8	21	2.4	27	3.0
20	8	0.9	10	1.2	16	1.8	22	2.5	28	3.2
21	8	0.9	10	1.2	17	1.9	23	2.6	29	3.3
22	9	1.0	11	1.2	17	1.9	24	2.7	30	3.4
23	9	1.0	11	1.2	18	2.0	25	2.8	31	3.6
24	9	1.0	11	1.3	18	2.1	25	2.9	33	3.7
25	9	1.0	11	1.3	19	2.1	26	3.0	34	3.8
26	9	1.0	12	1.3	19	2.2	27	3.1	35	3.9
27	9	1.1	12	1.4	20	2.3	28	3.2	36	4.1
28	9	1.1	12	1.4	21	2.3	29	3.3	37	4.2
29	10	1.1	13	1.4	21	2.4	30	3.4	38	4.3
30	10	1.1	13	1.4	22	2.5	31	3.5	39	4.5

Load vs. Speed vs Conveyor Length Per Width

NOTE: Maximum conveyor loads based on:

- Non-accumulating product
- Product moving towards gearmotor
- Conveyor being mounted horizontal

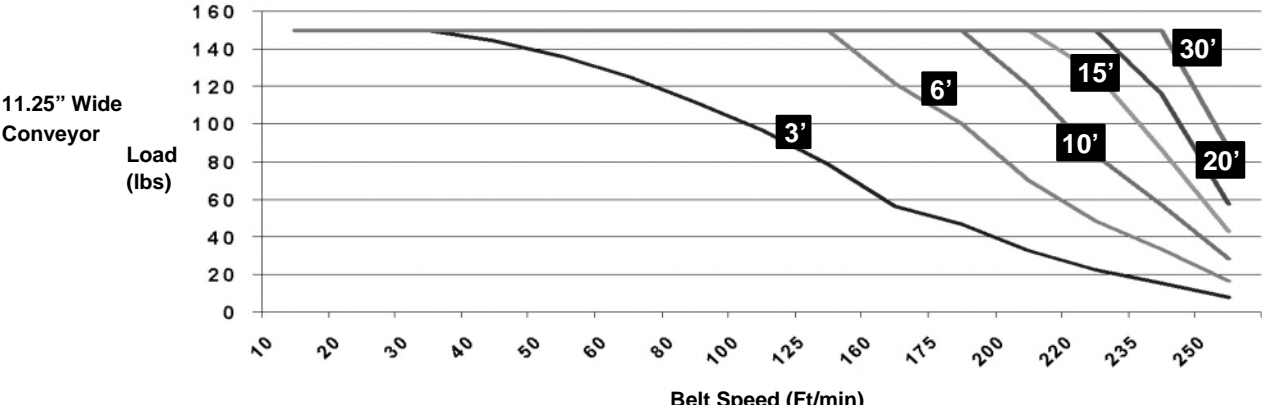
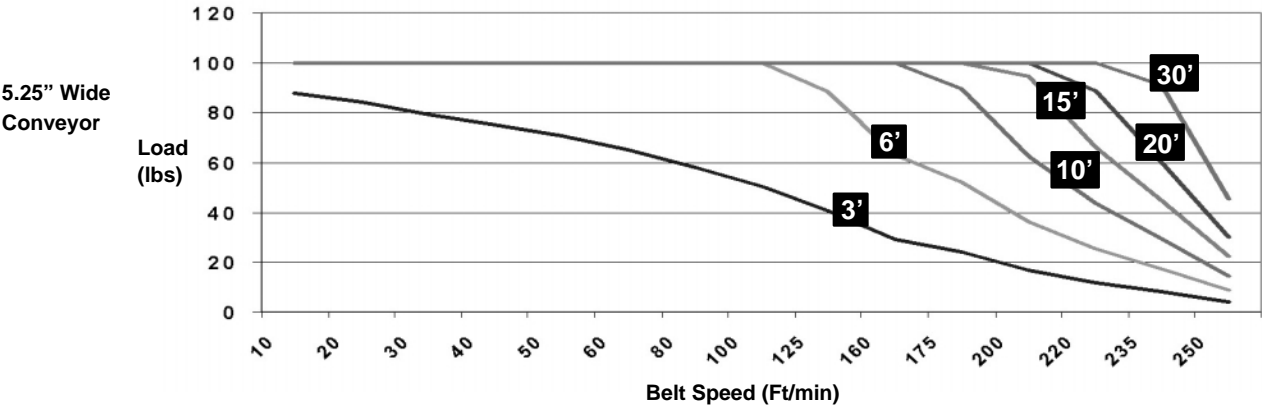
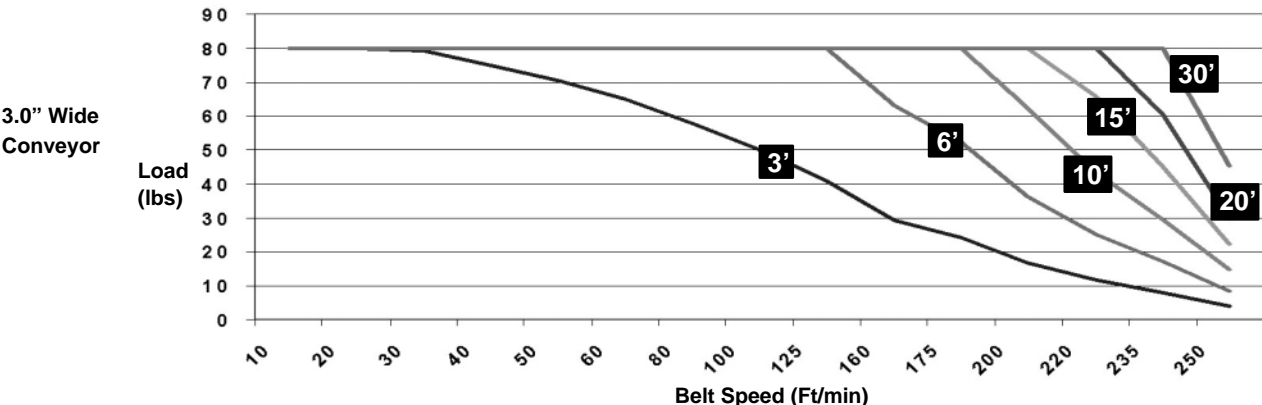

Specifications

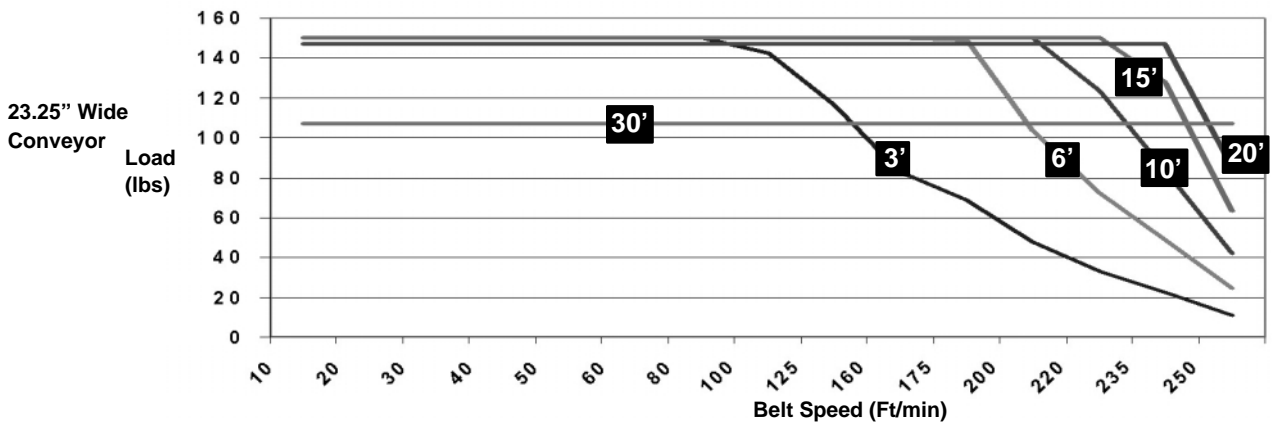
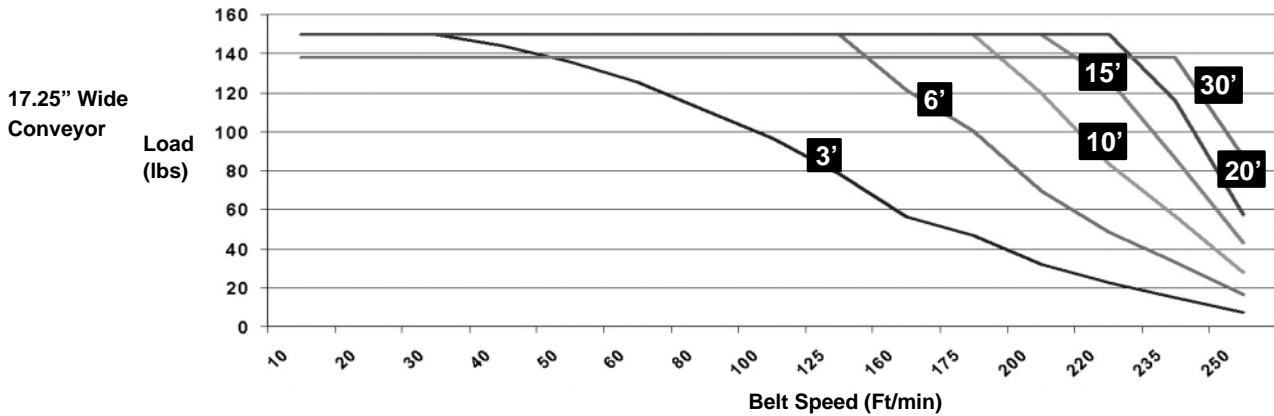

Installation

NOTE: Conveyor **MUST** be mounted straight, flat and level within confines of conveyor. Use a level (M of Figure 3) for setup.

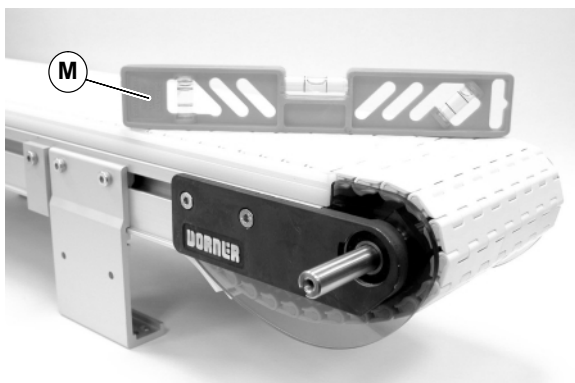

Figure 3

Required Tools

- Hex-key wrenches:
4 mm, 5 mm
- Level
- Torque wrench
- 3/32" (2.4 mm) wide Flat Blade screwdriver

Recommended Installation Sequence

- Install support stands (see accessory instructions)
- Assemble conveyor frame(if required)(page 6)
- Attach mounting brackets to conveyor frame and stands (page 7)
- Install Belt (page 8)
- Mount gearmotor mounting package (see accessory instructions)
- Attach guides/accessories (see page 31 through 35 of "Service Parts" section for details)

Conveyors Up to 13 ft (3962 mm)

No assembly is required. Install mounting brackets. Refer to “Mounting Brackets” on page 7.

Conveyors Longer Than 13 ft (3962 mm)

NOTE: Conveyors shipped in multiple sections will have a return wearstrip extending from the end of the conveyor. See Figure 4.

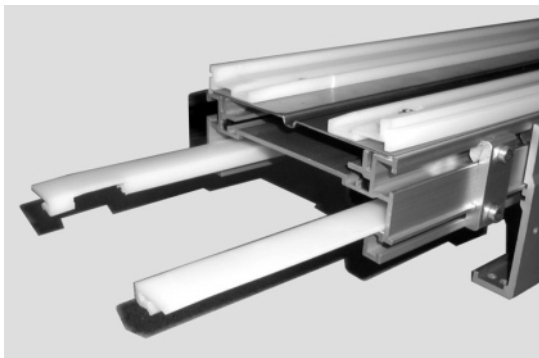

Figure 4

1. Locate conveyor sections (N Figure 5)

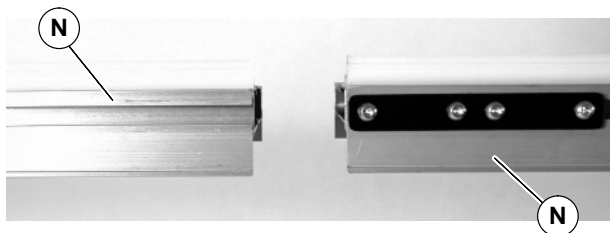

Figure 5

2. Join conveyor sections and install connector brackets (O of Figure 6) or connector/mount brackets (Q) and screws (P) on both sides as indicated.

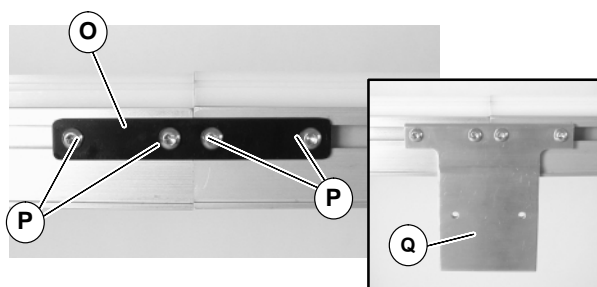

Figure 6

3. Snap the protruding return wear strip to the extrusion on the opposite side (R of Figure 7).

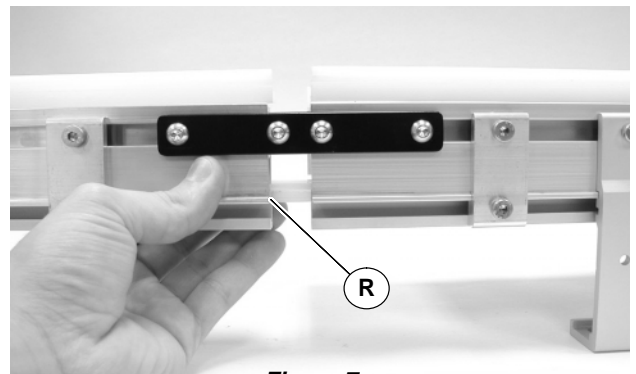
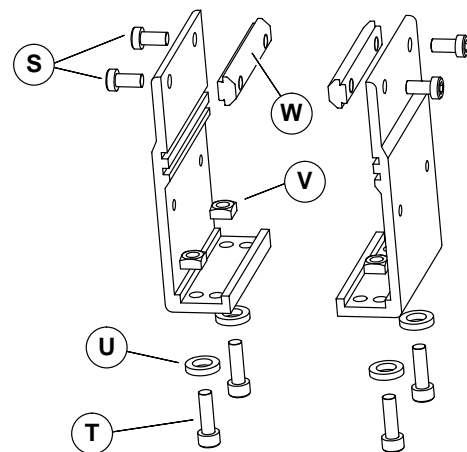

Figure 7

4. Tighten screw (P of Figure 6) to 60in-lb (7 N-m) on both sides of conveyor.

Mounting Brackets

1. Locate brackets. Exploded views shown in Figures 8 & 9.



Mounting Brackets for Flat Belt Conveyor

Figure 8

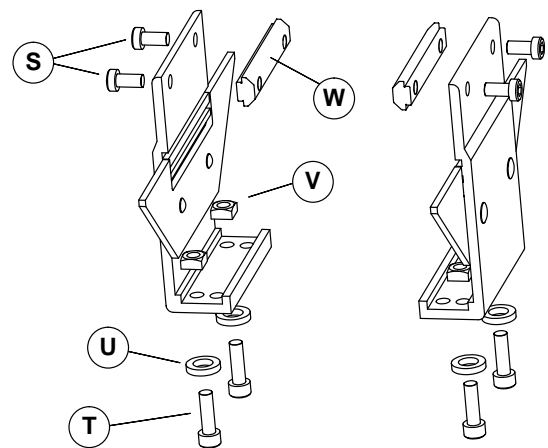

Mounting Brackets for Cleated Belt Conveyor

Figure 9

Installation

2. Remove screws (S & T of Figures 8 & 9), washers (U), nuts (V) and T-bars (W) from brackets.
3. Insert T-bars (W of Figures 8 & 9) into conveyor side slots (X of Figure 10). Fasten brackets (Y of Figure 10) to conveyor with mounting screws (S).

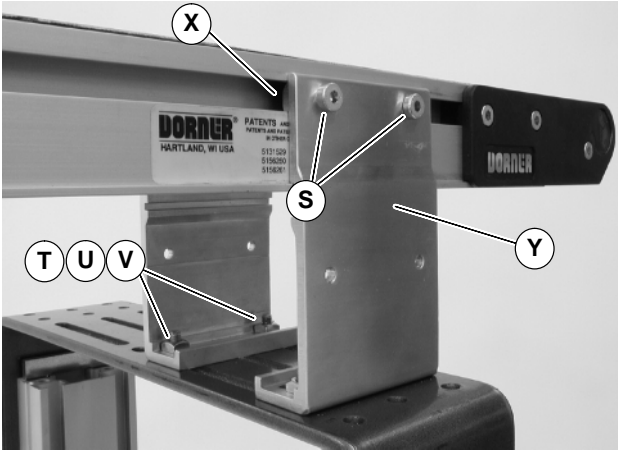

Figure 10

NOTE: Mounting brackets for flat belt conveyors shown.

4. Fasten brackets to support stand with mounting screws (T of Figure 10), washers (U) and nuts (V).
5. Tighten screws (S & T of Figure 10) to 60 in-lb (7 N-m).

Installing Plastic Belt

NOTE: 17.25" and 23.25" wide plastic belt will correctly operate in one direction only. Ensure the belt is installed in the correct orientation. Refer to step 2 below for details.

1. Locate the conveyor belt retaining rod (Z of Figure 11) and belt end caps (AA).

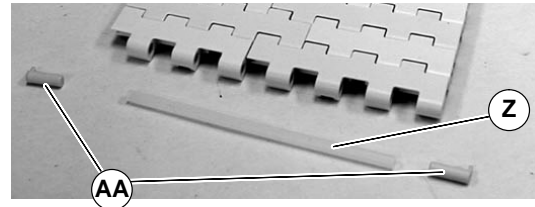

Figure 11

2. For 17.25" wide and 23.25" wide belts, align the belt to the retained center sprocket (AB of Figure 12) on the drive end of the conveyor.

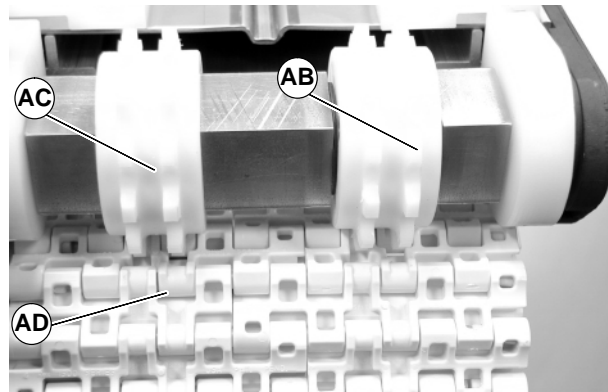

Figure 12

3. Feed belt into bottom wear strips (AE of Figure 13) and pull through to the far end.

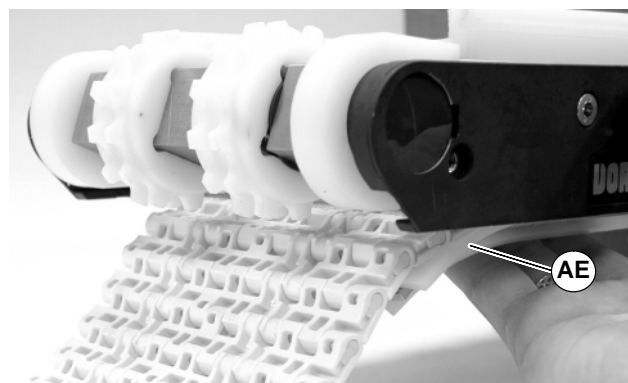

Figure 13

4. Aligning free moving sprocket(s) (AC of figure 12) to the drive pocket(s) (AD). Wrap belt around sprockets and pull towards idler end.
5. Repeat step 4 for the idler end of conveyor.

6. Splice the belt together by pushing the plastic rod (AF of Figure 14) through the side hole.

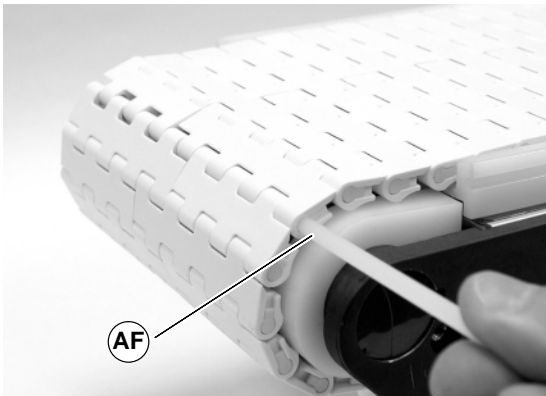

Figure 14

7. Insert rod retaining end caps (AG of figure 15) on both sides of belt.

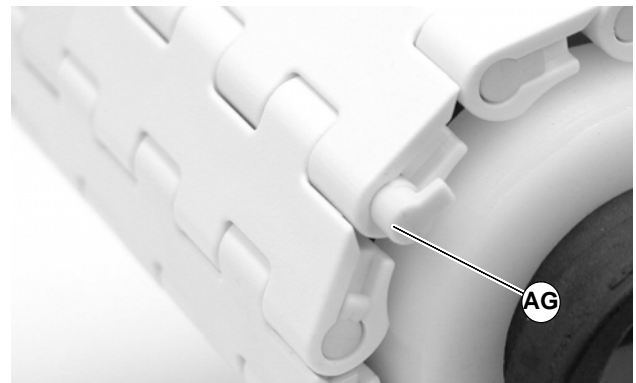

Figure 15

8. See “Conveyor Belt Tensioning” section on page 11 for details on belt tension.

Preventative Maintenance and Adjustment

Required Tools

Standard Tools

- Hex-key wrenches:
2.5 mm, 4 mm, 5 mm
- 3/32” (2.4 mm) wide Flat Blade screw driver
- Arbor press
- Adjustable wrench to 1” (25 mm) wide

Special Tools

- 807–1078 Sealed Bearing Removal Tool
- 450292 Sealed Bearing Installation Tool

Checklist

- Keep service parts on hand (see “Service Parts” section for recommendations)
- Keep supply of belt cleaner (part # 625619)
- Clean entire conveyor while disassembled
- Replace worn or damaged parts

Lubrication

No lubrication is required. Replace bearings if worn.

Maintaining Conveyor Belt

Troubleshooting

Inspect conveyor belt for:

- Surface cuts or wear

- Tooth skipping
- Loose links

Surface cuts and wear indicate:

- Sharp or heavy parts impacting belt
- Jammed parts
- Foreign material inside the conveyor
- Improperly positioned accessories
- Bolt-on guiding is pinching belt

Stalling or skipping belt indicates:

- Belt stretching
- Conveyor belt or drive timing belt are not properly tensioned
- Worn sprocket or impacted dirt on drive pulley
- Intermittent jamming or drive train problems

NOTE: Visit www.dorner.com for complete list of troubleshooting solutions.

Cleaning

IMPORTANT: Do not use belt cleaners that contain alcohol, acetone, Methyl Ethyl Ketone (MEK) or other harsh chemicals.

Use Dorner Belt Cleaner (part # 625619). Mild soap and water may also be used. Do not soak the belt.

Preventive Maintenance and Adjustment

Conveyor Belt Replacement



Conveyor Belt Replacement Sequence

- Remove old conveyor belt
- Install new conveyor belt
- Tension conveyor belt

Belt Removal

1. On idler end of the conveyor identified with a  label (AH of figure 16), loosen fastening screws (AI of figure 16) on both sides of conveyor. Push head plate assembly (AJ) inward.

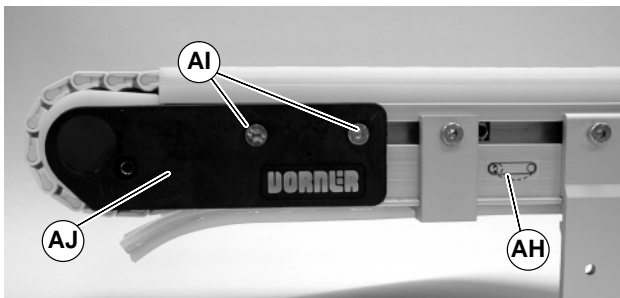

Figure 16

2. Choose one link on the idler end of chain to remove endcaps. With a 3/32" (2.4 mm) flat blade screwdriver, pry under tab of end caps (AK of Figure 17) and remove end cap. Repeat for opposite side of conveyor.



Figure 17

3. Insert screwdriver (AL of figure 18) into one side of belt, pushing rod (AM) out. Remove rod and separate belt.

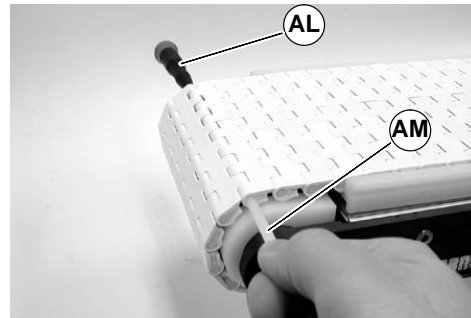

Figure 18

4. Pull back topside of belt to the drive end of the conveyor. See figure 19.

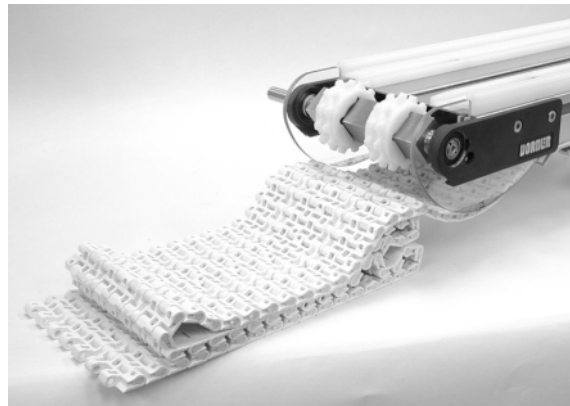

Figure 19

5. Remove belt by pulling belt out of bottom wear strips. See figure 20.

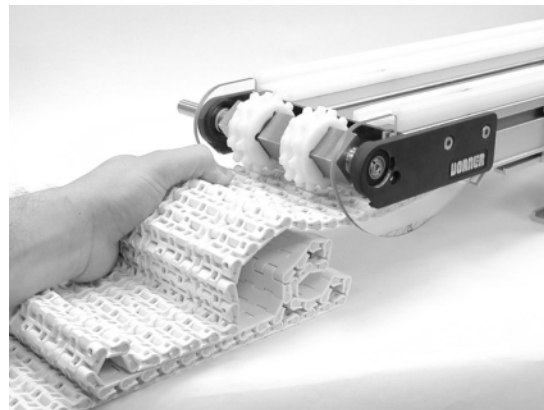

Figure 20

Belt Installation

1. See "Installing Plastic Belt" page 8.

Preventive Maintenance and Adjustment

Conveyor Belt Tensioning

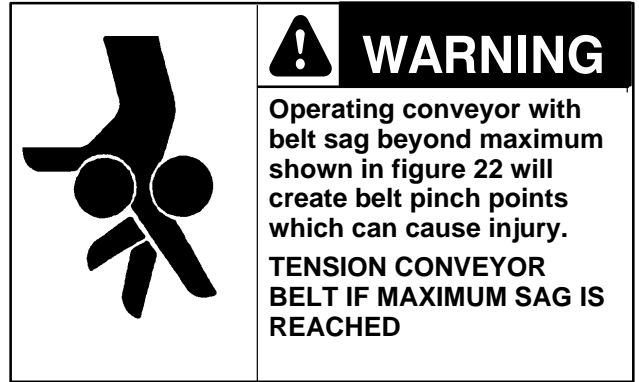
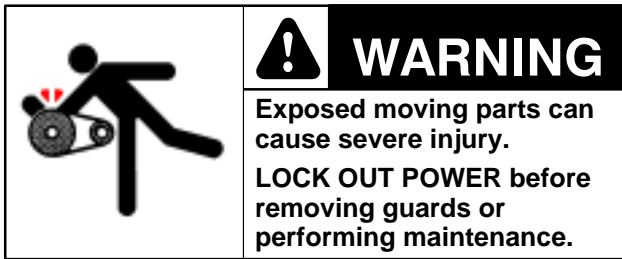

NOTE: The MPB Series Plastic Belt Conveyor is designed to operate with minimal belt tension. The belt sag guard (AN of figure 21) provides information to the proper belt tension. Figure 21 indicates minimum belt sag. Figure 22 indicates maximum belt sag. Belt sag beyond that indicated in Figure 22 must be tensioned see below for details.

Belt tensioning may be done by two methods:

- A – Extending idler end
- B – Removal of belt links

A – Extending Idler End

1. On tension end of the conveyor, identified with a  label (AH of Figure 23), on both sides of conveyor, loosen fastening screws (AI). Insert 5mm Hex wrench into pinion gear (AO) and rotate to extend head plate assembly(AH).



Figure 21

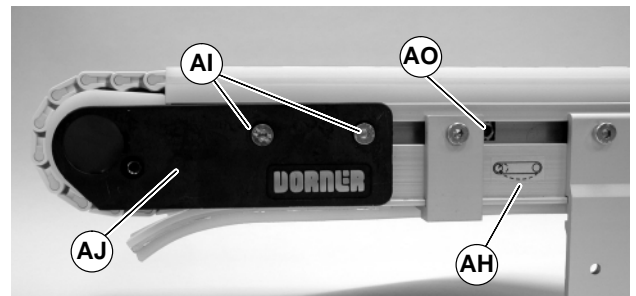

Figure 23



Figure 22

2. Extend head plate assembly so belt sag is between minimum shown in figure 21 and maximum shown in figure 22. If proper tensioning cannot be obtained before (AP of Figure 24) is even with the end of the conveyor frame (AQ), belt links must then be removed. See section “B Removal of Belt Links”.

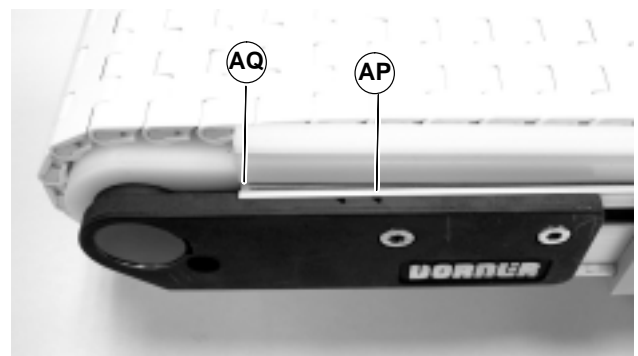

Figure 24

Preventive Maintenance and Adjustment

3. After adjusting proper tensioning, tighten fastening screws (AI of Figure 23) on both sides of conveyor to 60 in-lb (7 N-m).

B – Removal of Belt Links

1. Choose one link on the idler end of chain to remove endcaps. With a 3/32" (2.4 mm) flat blade screwdriver, pry under tab of end caps (AK of Figure 25) and remove end cap. Repeat for opposite side of conveyor.

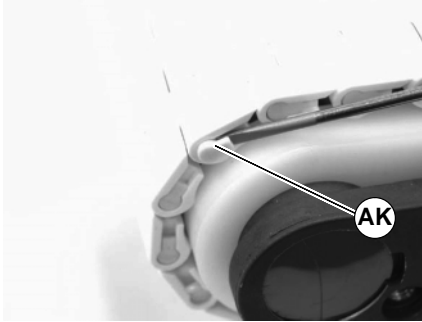

Figure 25

2. Insert screwdriver (AR of figure 26) into one side of belt, pushing rod (AS) out. Remove rod and separate belt.

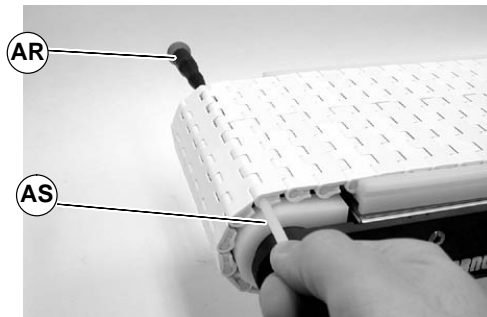

Figure 26

3. Determine the number of links to be removed. Start with 1 link and progress if additional tensioning is required repeat steps 1 and 2.

4. Splice the belt together by pushing the plastic rod (AF of Figure 27) through the side hole.

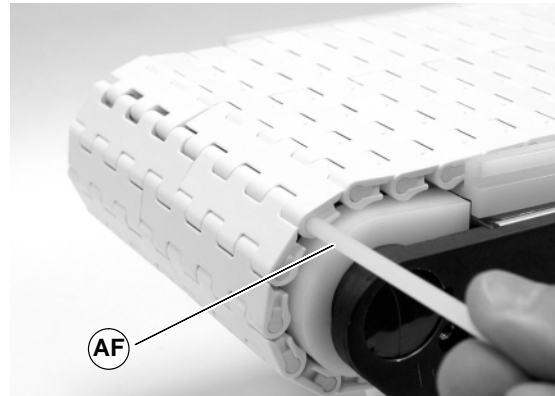

Figure 27

5. Insert rod retaining end caps (AG of figure 28) on both sides of belt.



Figure 28

6. Review belt sag at drive end to ensure it is between minimum shown in figure 21 and maximum shown in figure 22. If additional tensioning is required repeat steps 1 through 5.

Preventive Maintenance and Adjustment

Pulley and Sprockets Removal



Remove conveyor belt to access pulley(s). See “Conveyor Belt Replacement” on page 10. Remove the desired pulley following the corresponding instructions below:

- A – Idler Pulley and Sprockets Removal
- B – Drive Pulley and Sprockets Removal

A – Idler Pulley and Sprockets Removal

1. On both sides of conveyor, loosen two (2) fastening screws (AI of Figure 29). Then slide idler pulley assembly out from the conveyor frame.

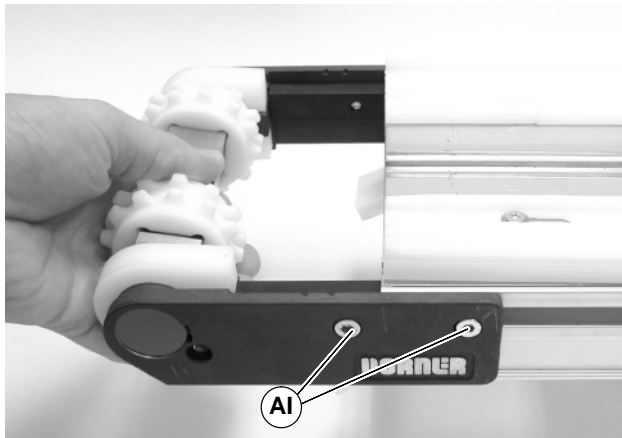

Figure 29

2. Remove bearing covers (AT of Figure 30).

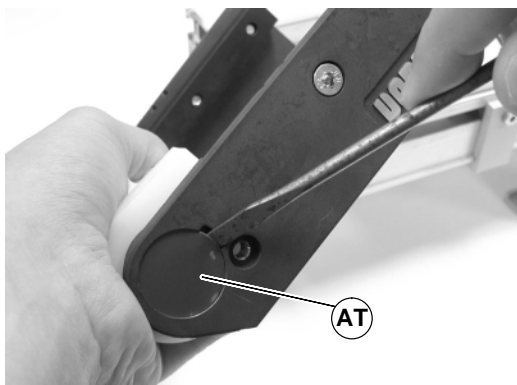

Figure 30

3. With 4mm hex-key wrench, loosen pulley taper screw (AU of Figure 31). Steady pulley (AV) with adjustable wrench (AW). Repeat procedure for opposite side of pulley.

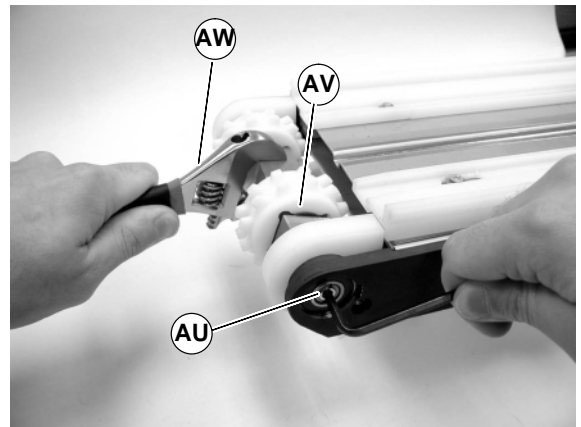

Figure 31

4. Remove head plates with bearings from the pulley.
5. Slide idler end guard (AX of Figure 32) from ends of pulley (AY).

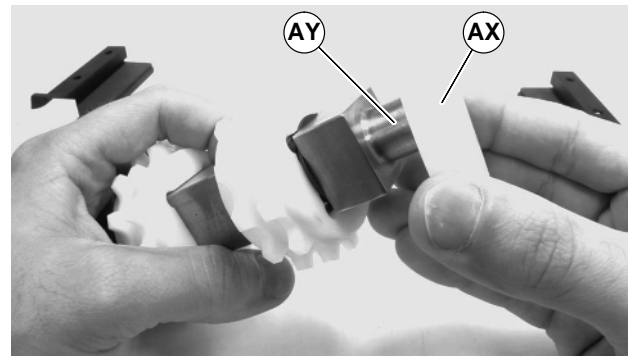

Figure 32

6. Slide free moving sprocket(s) (AZ of Figure 33) off the end of pulley (BA).

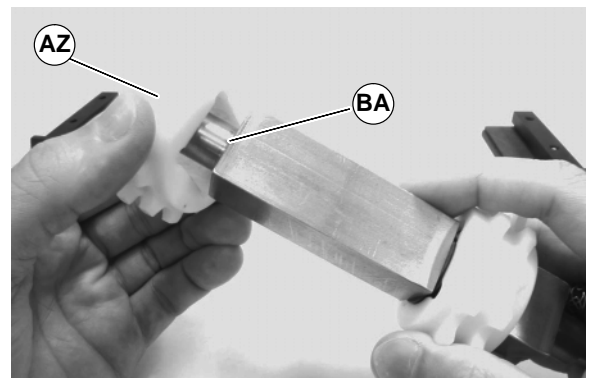

Figure 33

Preventive Maintenance and Adjustment

- Remove snap rings (BB of Figure 34). Slide drive sprocket (BC) off the end of pulley (BD).

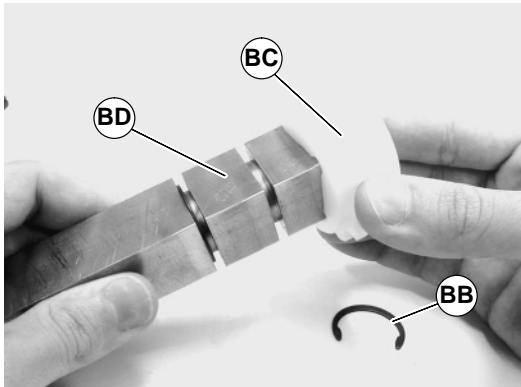

Figure 34

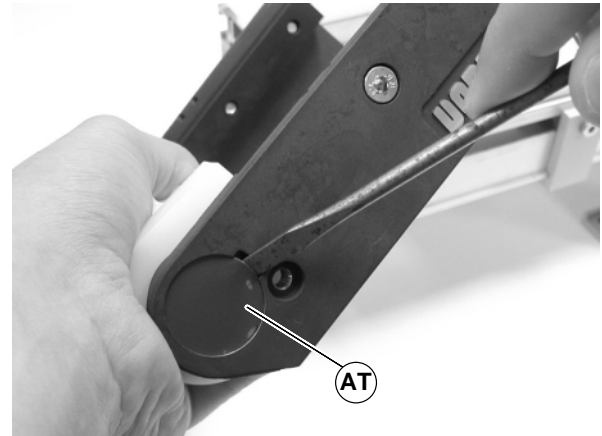

Figure 36

- On side opposite of drive shaft, loosen pulley taper screw (AU of Figure 37) with 4mm hex-key wrench. Steady pulley (AV) with adjustable wrench (AW).

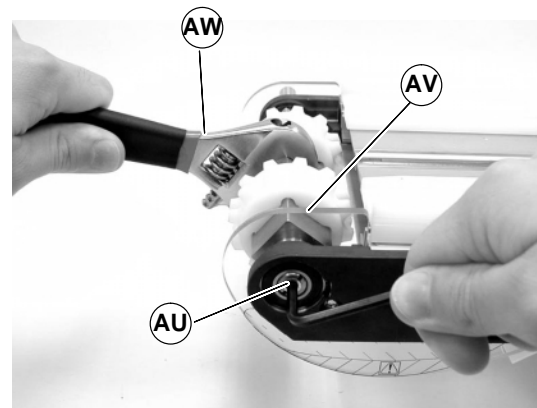

Figure 37

B – Drive Pulley and Sprockets Removal



- On both sides of conveyor, loosen two (2) fastening screws (BE of Figure 35). Then slide drive pulley assembly out from the conveyor frame.

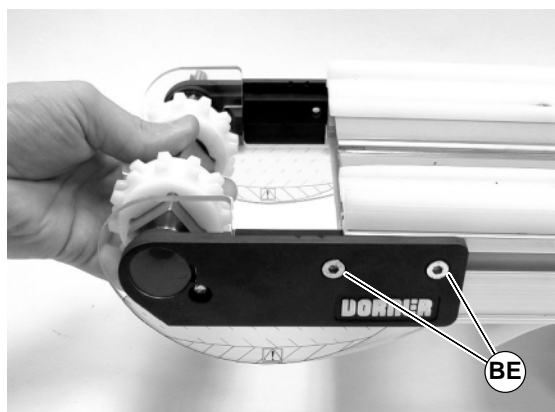

Figure 35

- Remove bearing cover (AT of Figure 36) from side opposite of drive shaft.

- On side opposite of drive shaft, pull head plate with bearings off from the pulley.
- With bearing removal tool, (BF of Figure 38), part number 807-1078, remove head plate from drive shaft side of pulley. Connect tool jaws at indicated points (BG).

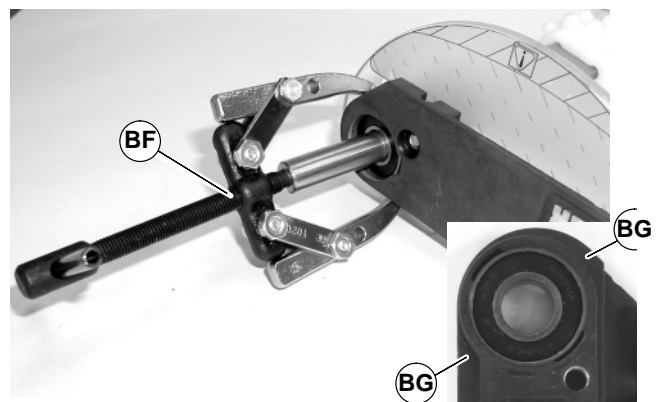

Figure 38

Preventive Maintenance and Adjustment

- Slide free moving sprocket(s) (AZ of Figure 39) off the end of pulley (BA).

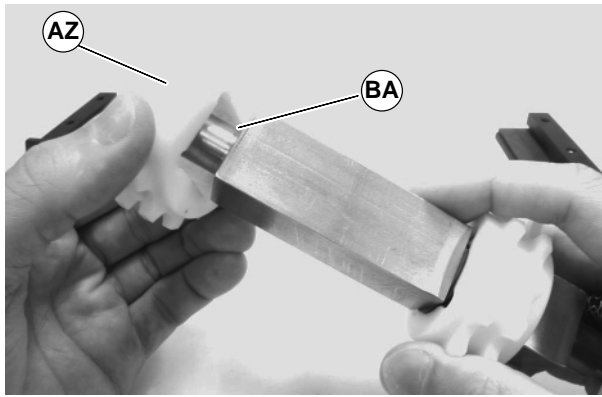

Figure 39

- Remove snap rings (BB of Figure 40). Slide drive sprocket (BC) off the end of pulley (BD).

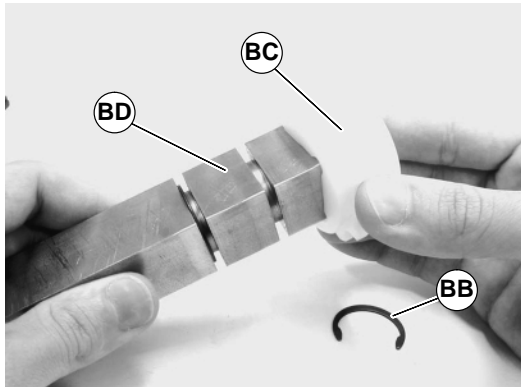

Figure 40

Bearing Removal & Replacement



Removal

- Remove idler pulley or drive pulley. For idler pulley see section “A – Idler Pulley and Sprockets Removal”, steps 1 through 4. For drive pulley see section “B – Drive Pulley and Sprockets Removal”, steps 1 through 5.
- For drive end head plates, remove screw (BH of Figure 41) and remove belt sag guard (BI).

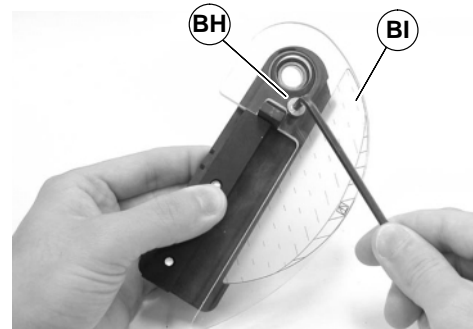

Figure 41

- Turn bearing (BJ of Figure 42) to align with slots (BK) in head plate. Then remove bearing.



Figure 42

Preventive Maintenance and Adjustment

Replacement

1. Inspect head plate bearing surface. If worn or damaged, replace head plate. See “Service Parts” on page 20.
2. Insert bearing (BJ of Figure 43) into head plate slot and twist bearing to fit into bearing enclosure.

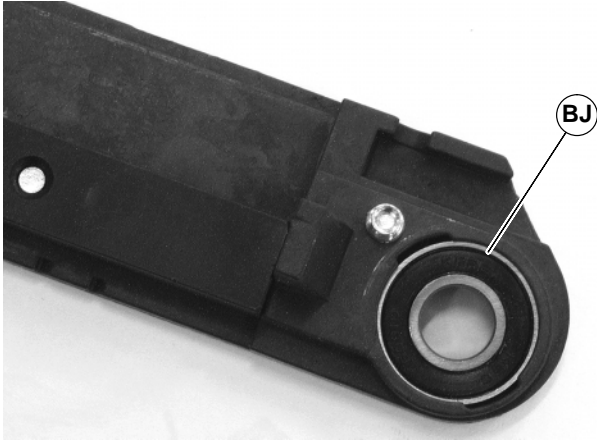

Figure 43

3. As required, install free moving sprockets as per Figure 46, items in bold are the fixed drive sprockets.

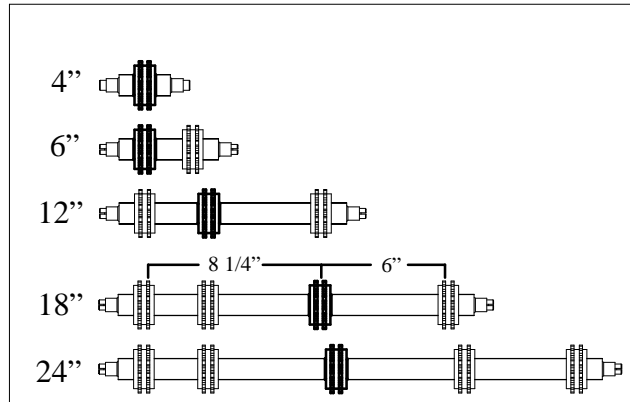

Figure 46

4. With bearing installed in head plate, use a bearing installation tool, (BM of Figure 47), part number 450292, to press the bearing onto the drive shaft.

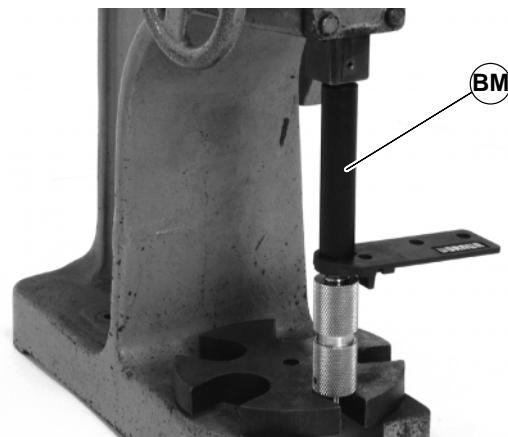

Figure 47

Pulley and Sprockets Replacement

Drive Pulley and Sprockets

1. Install sag guard (BI of Figure 44) to headplate (BL) with screw (BH). Repeat for opposite headplate.

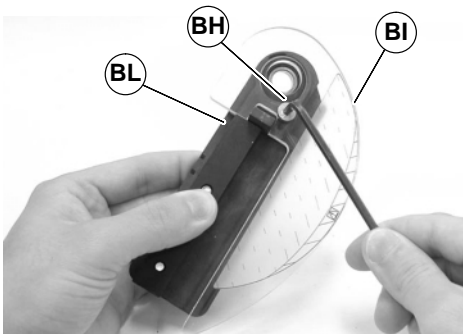

Figure 44

2. Install drive sprocket (BC of Figure 45) with snap rings (BB) to pulley (BD).

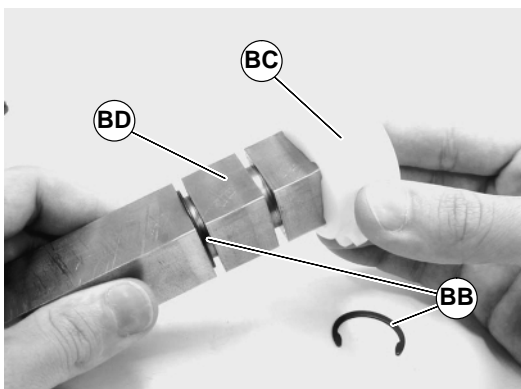

Figure 45

5. With bearing installed in head plate, press bearing on to non-drive shaft (BN of Figure 48) of pulley.

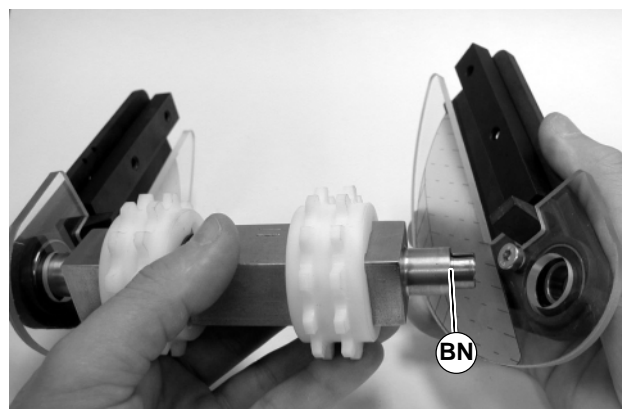

Figure 48

Preventive Maintenance and Adjustment

NOTE: DO NOT tighten non-drive shaft bearing taper screws at this time.

6. Install pulley assembly on conveyor. On both sides of conveyor tighten fastening screws (BE of Figure 49) to 60 in-lb (7 N-m).

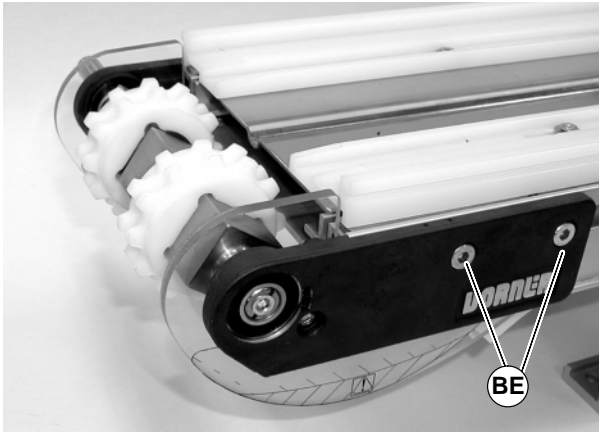

Figure 49

7. With 4mm hex-key wrench, tighten pulley taper screw (AU of Figure 50) to 35 in-lb (4 N-m). Steady pulley (AV) with wrench (AW).

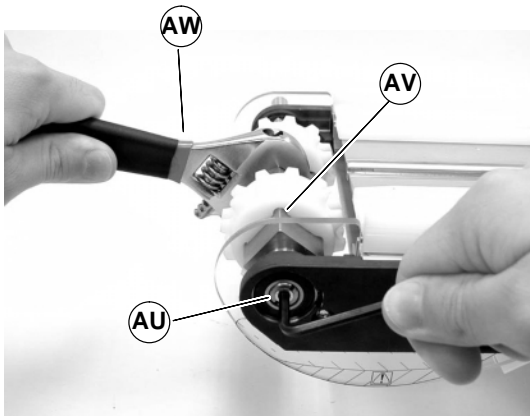

Figure 50

8. Install bearing cover (AT of Figure 51).

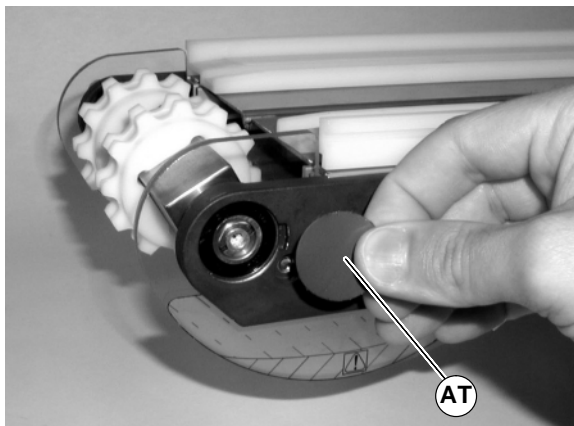

Figure 51

Idler Pulley and Sprockets

1. Install drive sprocket (BC of Figure 45) with snap rings (BB) to pulley (BD).

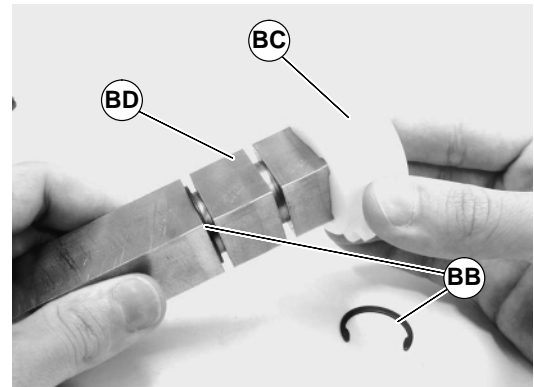

Figure 52

2. As required, install free moving sprockets as per Figure 46, items in bold are the fixed drive sprockets.

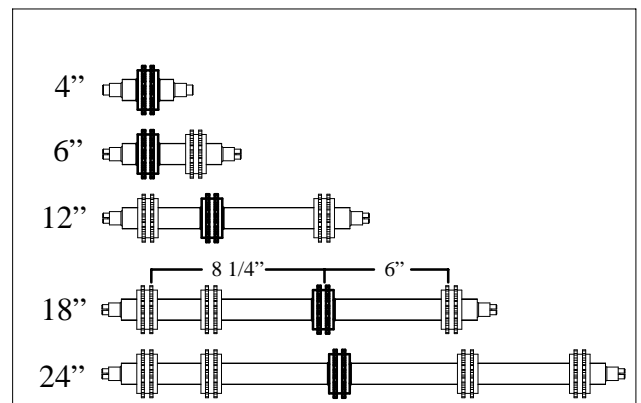

Figure 53

3. Install idler guard (BO of Figure 54) on the end of pulley (BN). With bearing installed in head plate, press bearing on to shaft (BN) of pulley.

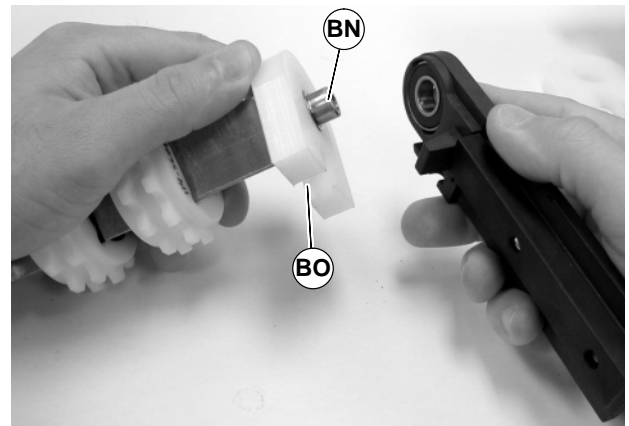

Figure 54

Preventive Maintenance and Adjustment

NOTE: DO NOT tighten shaft bearing taper screws at this time.

- Repeat step 1 on opposite side of pulley.
- Install pulley assembly on conveyor. On both sides of conveyor, tighten screws (BE of Figure 55) to 60 in-lb (7 N-m).

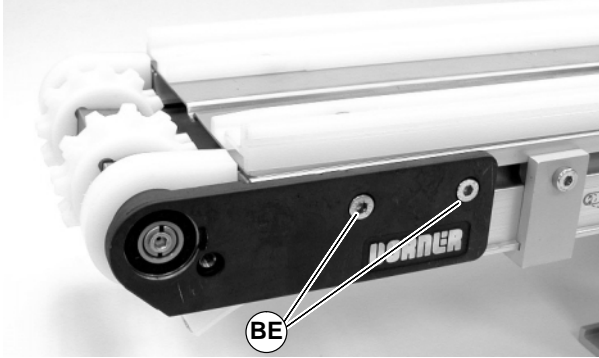

Figure 55

- On both sides of pulley, use a 4mm hex-key wrench to tighten pulley taper screw (AU of Figure 56) to 35 in-lb (4 N-m). Steady pulley (AV) with wrench (AW) with wrench (AW).

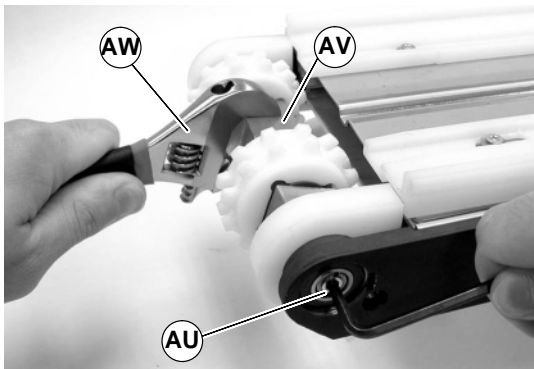

Figure 56

- Install bearing covers (AT of Figure 57).

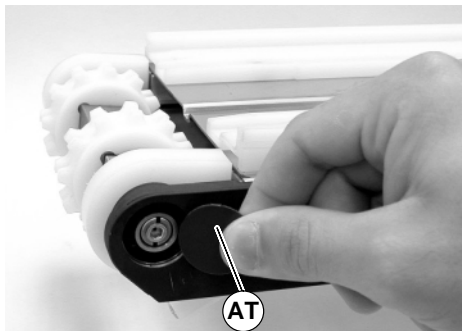

Figure 57

Upper Wear Strip Replacement



WARNING

Exposed moving parts can cause severe injury.

LOCK OUT POWER before removing guards or performing maintenance.

- Remove conveyor belt. See “Belt Removal” section on page 10.
- With a T-20 Torx head wrench, remove screw (BP of Figure 58) and bushings (BQ). Remove old wear strip.

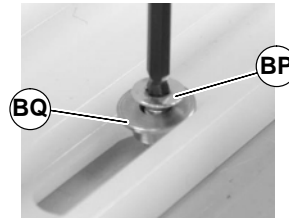

Figure 58

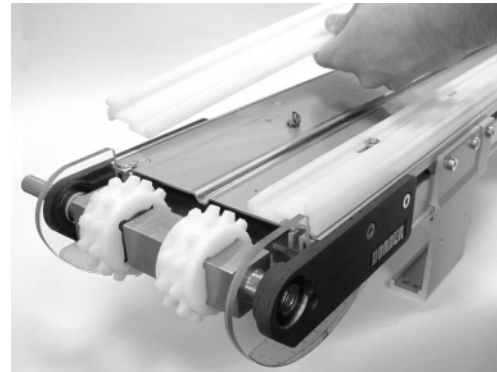

Figure 59

- Install new wear strip, with bushings (BQ) and screws (BP). Tighten screws to 25 in-lb (2.8 N-m).

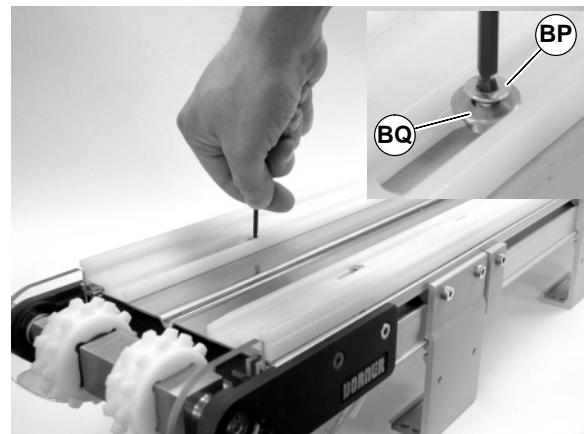



Figure 60

Preventive Maintenance and Adjustment

Return Wear Strip Replacement

	<p>! WARNING</p> <p>Exposed moving parts can cause severe injury.</p> <p>LOCK OUT POWER before removing guards or performing maintenance.</p>
---	---

1. Remove old wear strip (BR) by sliding off of support extrusion (BS of Figure 61).

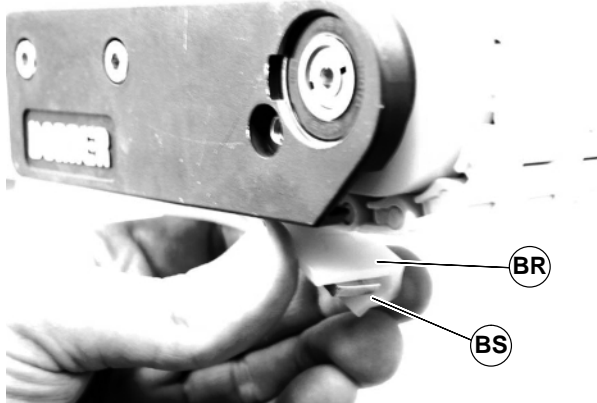

Figure 61

2. Install new wearstrip onto support extrusion (BS).

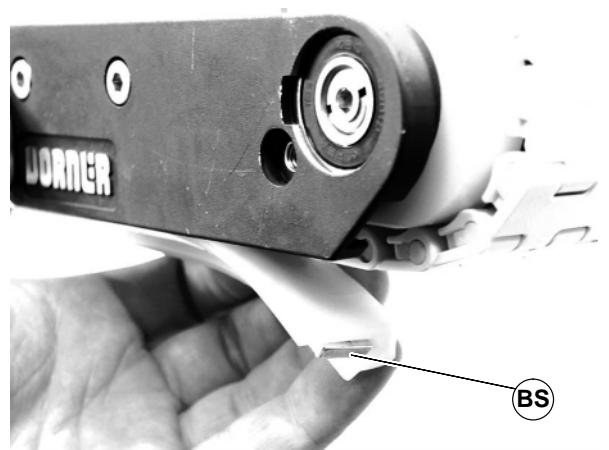
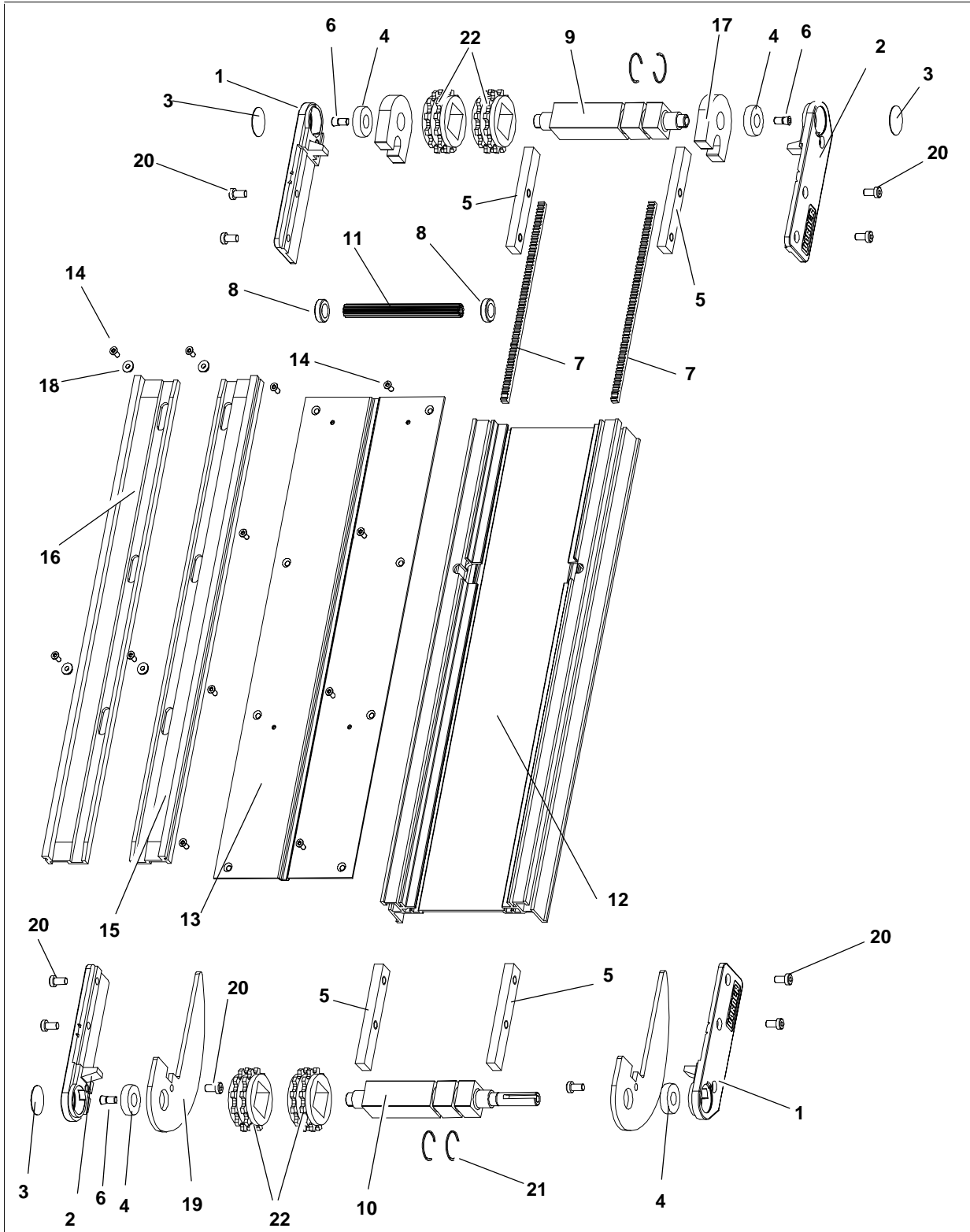

Figure 62

Service Parts

NOTE: For replacement parts other than those shown on this page, contact an authorized Dorner Service Center or the factory.

4" (102mm) and 6" (152mm) Wide Conveyor Assembly



Service Parts

Item	Part Number	Description
1	240325	Head Plate LH
2	240326	Head Plate RH
3	240327	Bearing Cover Disk
4	240328	Bearing
5	240329	Tension Slide Bar
6	240330	Taper Screw
7	240420	Rack Gear 14.5 PA x 24 P
8	240421	Pinion Bushing
9	245504	4" MPB Idler Spindle
	245506	6" MPB Idler Spindle
10	245704	4" MPB Drive Spindle
	245706	6" MPB Drive Spindle
11	203004M	Gear Pinion 4" (102mm)
	203006M	Gear Pinion 6" (152mm)
12	See Chart Below	Conveyor Frame
13	See Chart Below	Bed Plate
14	807-1105	Torx, Flat Head M4 x 10mm
15	245827-LLLL	LH Outer Wear Strip - UHMW
	245828-LLLL	LH Outer Wear Strip - Antistat
16	245829-LLLL	RH Outer Wear Strip - UHMW
	245830-LLLL	RH Outer Wear Strip - Antistat
17	245850	Pinch Guard Block
18	245854	Screw Sleeve
19	245858	Sag Guard
20	920692M	Socket Head Screw M6 x 12mm
21	807-1108	Retaining Ring
22	807-1106	MPB Spindle Sprocket

Item 12: Conveyor Frame

Length	Part Number
2' (610mm)	2404WW-01900
3' (914mm)	2404WW-03100
4' (1219mm)	2404WW-04300
5' (1524mm)	2404WW-05500
6' (1829mm)	2404WW-06700
7' (2134mm)	2404WW-07900
8' (2438mm)	2404WW-09100
9' (2743mm)	2404WW-10300
10' (3048mm)	2404WW-11500
11' (3353mm)	2404WW-12700
12' (3658mm)	2404WW-13900
13' (3962mm)	2404WW-07200 2404WW-07908
14' (4267mm)	2404WW-07200 2404WW-09108
15' (4572mm)	2404WW-07200 2404WW-10308

16' (4877mm)	2404WW-07200 2404WW-11508
17' (5182mm)	2404WW-07200 2404WW-12708
18' (5486mm)	2404WW-07200 2404WW-13908
19' (5791mm)	2404WW-07900 2404WW-14400
20' (6096mm)	2404WW-09100 2404WW-14400
21' (6401mm)	2404WW-10300 2404WW-14400
22' (6706mm)	2404WW-11500 2404WW-14400
23' (7010mm)	2404WW-12700 2404WW-14400
24' (7315mm)	2404WW-13900 2404WW-14400
25' (7620mm)	2404WW-07900 2404WW-07200 2404WW-14400
26' (7925mm)	2404WW-09100 2404WW-07200 2404WW-14400
27' (8230mm)	2404WW-10300 2404WW-07200 2404WW-14400
28' (8534mm)	2404WW-11500 2404WW-07200 2404WW-14400
29' (8839mm)	2404WW-12700 2404WW-07200 2404WW-14400
30' (9144mm)	2404WW-13900 2404WW-07200 2404WW-14400

WW = Conveyor width reference: 04, 06

Item 13: Bed Plate

Length	Part Number
2' (610mm)	2452WW-01892
3' (914mm)	2452WW-03092
4' (1219mm)	2452WW-04292
5' (1524mm)	2452WW-05492
6' (1829mm)	2452WW-06692
7' (2134mm)	2452WW-07892
8' (2438mm)	2452WW-09092
9' (2743mm)	2452WW-10292
10' (3048mm)	2452WW-11492
11' (3353mm)	2452WW-12692
12' (3658mm)	2452WW-13892
13' (3962mm)	2452WW-07196 2452WW-07892
14' (4267mm)	2452WW-07196 2452WW-09092
15' (4572mm)	2452WW-07196 2452WW-10292
16' (4877mm)	2452WW-07196 2452WW-11492
17' (5182mm)	2452WW-07196 2452WW-12692
18' (5486mm)	2452WW-07196 2452WW-13892
19' (5791mm)	2452WW-07892 2452WW-13892
20' (6096mm)	2452WW-09092 2452WW-13892
21' (6401mm)	2452WW-10292 2452WW-13892
22' (6706mm)	2452WW-11492 2452WW-13892
23' (7010mm)	2452WW-12692 2452WW-13892
24' (7315mm)	2452WW-13892 2452WW-13892

Service Parts

25' (7620mm)	2452WW-07892 2452WW-07196	2452WW-13892
26' (7925mm)	2452WW-09092 2452WW-07196	2452WW-13892
27' (8230mm)	2452WW-10292 2452WW-07196	2452WW-13892
28' (8534mm)	2452WW-11492 2452WW-07196	2452WW-13892

29' (8839mm)	2452WW-12692 2452WW-07196	2452WW-13892
30' (9144mm)	2452WW-13892 2452WW-07196	2452WW-13892
WW = Conveyor Width reference: 04, 06		

12" (305mm) Wide Conveyor Assembly

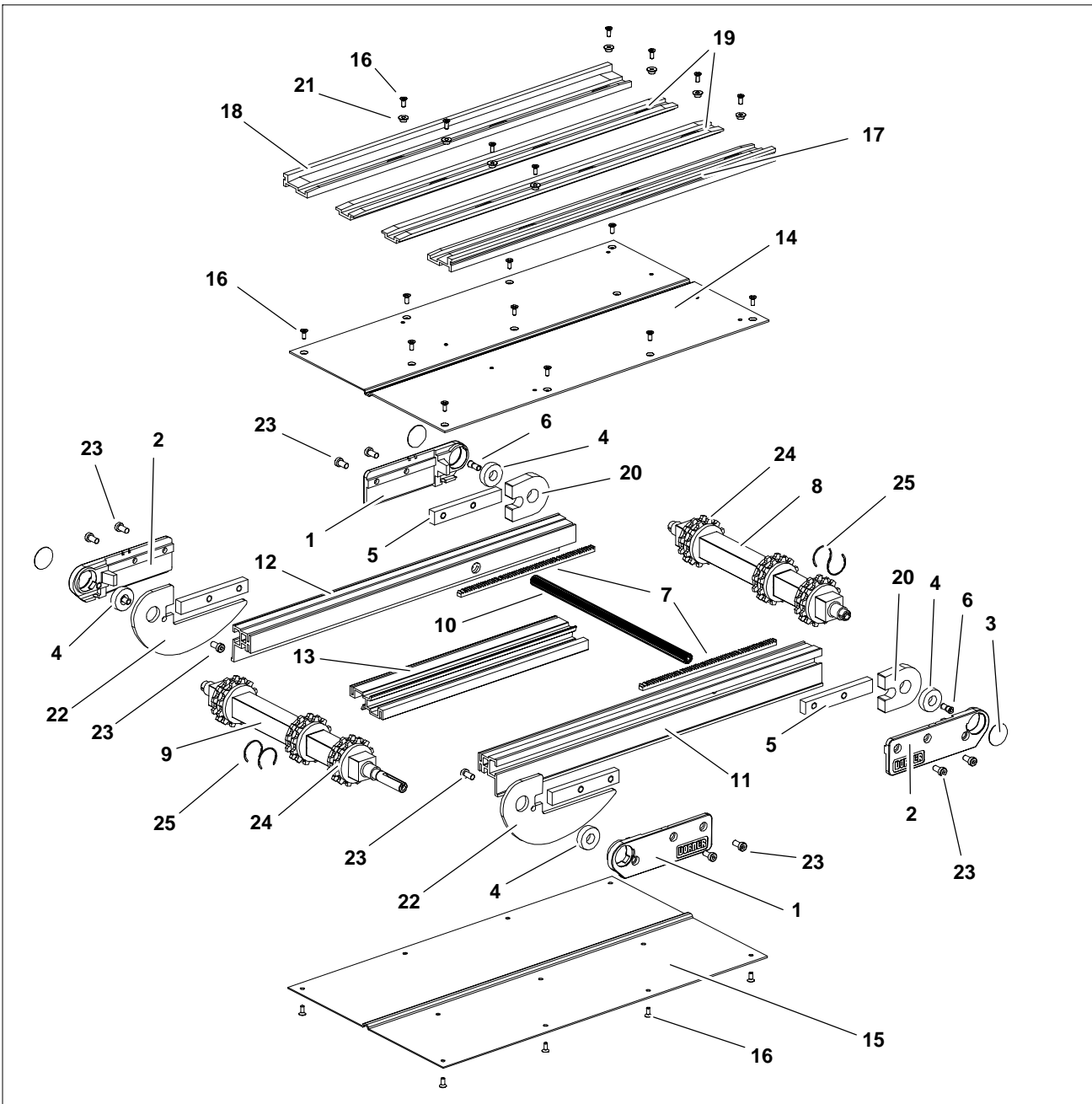

Item	Part Number	Description
1	240325	Head Plate LH
2	240326	Head Plate RH
3	240327	Bearing Cover Disk
4	240328	Bearing
5	240329	Tension Slide Bar

6	240330	Taper Screw
7	240420	Rack Gear 14.5 PA x 24 P
8	245512	12" MPB Idler Spindle
9	245712	12" MPB Drive Spindle
10	203012M	Gear Pinion 12" (605mm)

Service Parts

11	See Chart Below	Conveyor Frame
12	See Chart Below	Conveyor Frame
13	See Chart Below	Center Rail
14	See Chart Below	Bed Plate Top
15	See Chart Below	Bed Plate Bottom
16	807-1105	Torx, Flat Head M4 x 10mm
17	245827-LLLL	LH Outer Wear Strip – UHMW
	245828-LLLL	LH Outer Wear Strip – Antistat
18	245829-LLLL	RH Outer Wear Strip – UHMW
	245830-LLLL	RH Outer Wear Strip – Antistat
19	245831-LLLL	Center Wear Strips – UHMW
	245832-LLLL	Center Wear Strips – Antistat
20	245850	Pinch Guard Block
21	245854	Screw Sleeve
22	245858	Sag Guard
23	920692M	Socket Head Screw M6 x 12mm
24	807-1106	MPB Spindle Sprocket
25	807-1108	Retaining Ring

Item 11: Side Rail RH 12" Wide (305mm)	
Length	Part Number
2' (610mm)	240412-01900
3' (914mm)	240412-03100
4' (1219mm)	240412-04300
5' (1524mm)	240412-05500
6' (1829mm)	240412-06700
7' (2134mm)	240412-07900
8' (2438mm)	240412-09100
9' (2743mm)	240412-10300
10' (3048mm)	240412-11500
11' (3353mm)	240412-12700
12' (3658mm)	240412-13900
13' (3962mm)	240412-07200 240412-13900
14' (4267mm)	240412-07200 240412-13900
15' (4572mm)	240412-07200 240412-13900
16' (4877mm)	240412-07200 240412-13900
17' (5182mm)	240412-07200 240412-13900
18' (5486mm)	240412-07200 240412-13900
19' (5791mm)	240412-07900 240412-13900
20' (6096mm)	240412-09100 240412-13900
21' (6401mm)	240412-10300 240412-13900
22' (6706mm)	240412-11500 240412-13900
23' (7010mm)	240412-12700 240412-13900

24' (7315mm)	240412-13900 240412-13900
25' (7620mm)	240412-07900 240412-07200 240412-13900
26' (7925mm)	240412-09100 240412-07200 240412-13900
27' (8230mm)	240412-10300 240412-07200 240412-13900
28' (8534mm)	240412-11500 240412-07200 240412-13900
29' (8839mm)	240412-12700 240412-07200 240412-13900
30' (9144mm)	240412-13900 240412-07200 240412-13900

Item 12: Side Rail LH 12" Wide (305mm)	
Length	Part Number
2' (610mm)	240413-01900
3' (914mm)	240413-03100
4' (1219mm)	240413-04300
5' (1524mm)	240413-05500
6' (1829mm)	240413-06700
7' (2134mm)	240413-07900
8' (2438mm)	240413-09100
9' (2743mm)	240413-10300
10' (3048mm)	240413-11500
11' (3353mm)	240413-12700
12' (3658mm)	240413-13900
13' (3962mm)	240413-07200 240413-13900
14' (4267mm)	240413-07200 240413-13900
15' (4572mm)	240413-07200 240413-13900
16' (4877mm)	240413-07200 240413-13900
17' (5182mm)	240413-07200 240413-13900
18' (5486mm)	240413-07200 240413-13900
19' (5791mm)	240413-07900 240413-13900
20' (6096mm)	240413-09100 240413-13900
21' (6401mm)	240413-10300 240413-13900
22' (6706mm)	240413-11500 240413-13900
23' (7010mm)	240413-12700 240413-13900
24' (7315mm)	240413-13900 240413-13900
25' (7620mm)	240413-07900 240413-07200 240413-13900
26' (7925mm)	240413-09100 240413-07200 240413-13900
27' (8230mm)	240413-10300 240413-07200 240413-13900
28' (8534mm)	240413-11500 240413-07200 240413-13900
29' (8839mm)	240413-12700 240413-07200 240413-13900
30' (9144mm)	240413-13900 240413-07200 240413-13900

Service Parts

Item 13: Center Rail 12" Wide (305mm)	
Length	Part Number
2' (610mm)	240414-01273
3' (914mm)	240414-02473
4' (1219mm)	240414-03673
5' (1524mm)	240414-04873
6' (1829mm)	240414-06073
7' (2134mm)	240414-07273
8' (2438mm)	240414-08473
9' (2743mm)	240414-09673
10' (3048mm)	240414-10873
11' (3353mm)	240414-12073
12' (3658mm)	240414-13273
13' (3962mm)	240414-07200 240414-07273
14' (4267mm)	240414-07200 240414-08473
15' (4572mm)	240414-07200 240414-09673
16' (4877mm)	240414-07200 240414-10873
17' (5182mm)	240414-07200 240414-12073
18' (5486mm)	240414-07200 240414-13273
19' (5791mm)	240414-07273 240414-13273
20' (6096mm)	240414-08473 240414-13273
21' (6401mm)	240414-09673 240414-13273
22' (6706mm)	240414-10873 240414-13273
23' (7010mm)	240414-12073 240414-13273
24' (7315mm)	240414-13273 240414-13273
25' (7620mm)	240414-07273 240414-07200 240414-13273
26' (7925mm)	240414-08473 240414-07200 240414-13273
27' (8230mm)	240414-09673 240414-07200 240414-13273
28' (8534mm)	240414-10873 240414-07200 240414-13273
29' (8839mm)	240414-12073 240414-07200 240414-13273
30' (9144mm)	240414-13273 240414-07200 240414-13273

Item 14: Bed Plate Top	
Length	Part Number
2' (610mm)	2452WW-01892
3' (914mm)	2452WW-03092
4' (1219mm)	2452WW-04292
5' (1524mm)	2452WW-05492
6' (1829mm)	2452WW-06692
7' (2134mm)	2452WW-07892
8' (2438mm)	2452WW-09092
9' (2743mm)	2452WW-10292
10' (3048mm)	2452WW-11492

11' (3353mm)	2452WW-12692
12' (3658mm)	2452WW-13892
13' (3962mm)	2452WW-07196 2452WW-07892
14' (4267mm)	2452WW-07196 2452WW-09092
15' (4572mm)	2452WW-07196 2452WW-10292
16' (4877mm)	2452WW-07196 2452WW-11492
17' (5182mm)	2452WW-07196 2452WW-12692
18' (5486mm)	2452WW-07196 2452WW-13892
19' (5791mm)	2452WW-07892 2452WW-13892
20' (6096mm)	2452WW-09092 2452WW-13892
21' (6401mm)	2452WW-10292 2452WW-13892
22' (6706mm)	2452WW-11492 2452WW-13892
23' (7010mm)	2452WW-12692 2452WW-13892
24' (7315mm)	2452WW-13892 2452WW-13892
25' (7620mm)	2452WW-07892 2452WW-07196 2452WW-13892
26' (7925mm)	2452WW-09092 2452WW-07196 2452WW-13892
27' (8230mm)	2452WW-10292 2452WW-07196 2452WW-13892
28' (8534mm)	2452WW-11492 2452WW-07196 2452WW-13892
29' (8839mm)	2452WW-12692 2452WW-07196 2452WW-13892
30' (9144mm)	2452WW-13892 2452WW-07196 2452WW-13892
WW = Conveyor Width reference: 12	

Item 15: Bed Plate Bottom	
Length	Part Number
2' (610mm)	2405WW-01892
3' (914mm)	2405WW-03092
4' (1219mm)	2405WW-04292
5' (1524mm)	2405WW-05492
6' (1829mm)	2405WW-06692
7' (2134mm)	2405WW-07892
8' (2438mm)	2405WW-09092
9' (2743mm)	2405WW-10292
10' (3048mm)	2405WW-11492
11' (3353mm)	2405WW-12692
12' (3658mm)	2405WW-13892
13' (3962mm)	2405WW-07196 2405WW-07892
14' (4267mm)	2405WW-07196 2405WW-09092
15' (4572mm)	2405WW-07196 2405WW-10292
16' (4877mm)	2405WW-07196 2405WW-11492
17' (5182mm)	2405WW-07196 2405WW-12692
18' (5486mm)	2405WW-07196 2405WW-13892
19' (5791mm)	2405WW-07892 2405WW-13892
20' (6096mm)	2405WW-09092 2405WW-13892

Service Parts

21' (6401mm)	2405WW-10292	2405WW-13892
22' (6706mm)	2405WW-11492	2405WW-13892
23' (7010mm)	2405WW-12692	2405WW-13892
24' (7315mm)	2405WW-13892	2405WW-13892
25' (7620mm)	2405WW-07892 2405WW-07196	2405WW-13892
26' (7925mm)	2405WW-09092 2405WW-07196	2405WW-13892

27' (8230mm)	2405WW-10292 2405WW-07196	2405WW-13892
28' (8534mm)	2405WW-11492 2405WW-07196	2405WW-13892
29' (8839mm)	2405WW-12692 2405WW-07196	2405WW-13892
30' (9144mm)	2405WW-13892 2405WW-07196	2405WW-13892
WW = Conveyor Width reference: 12		

Service Parts

18" (457mm) and 24" (610mm) Wide Conveyor Assembly

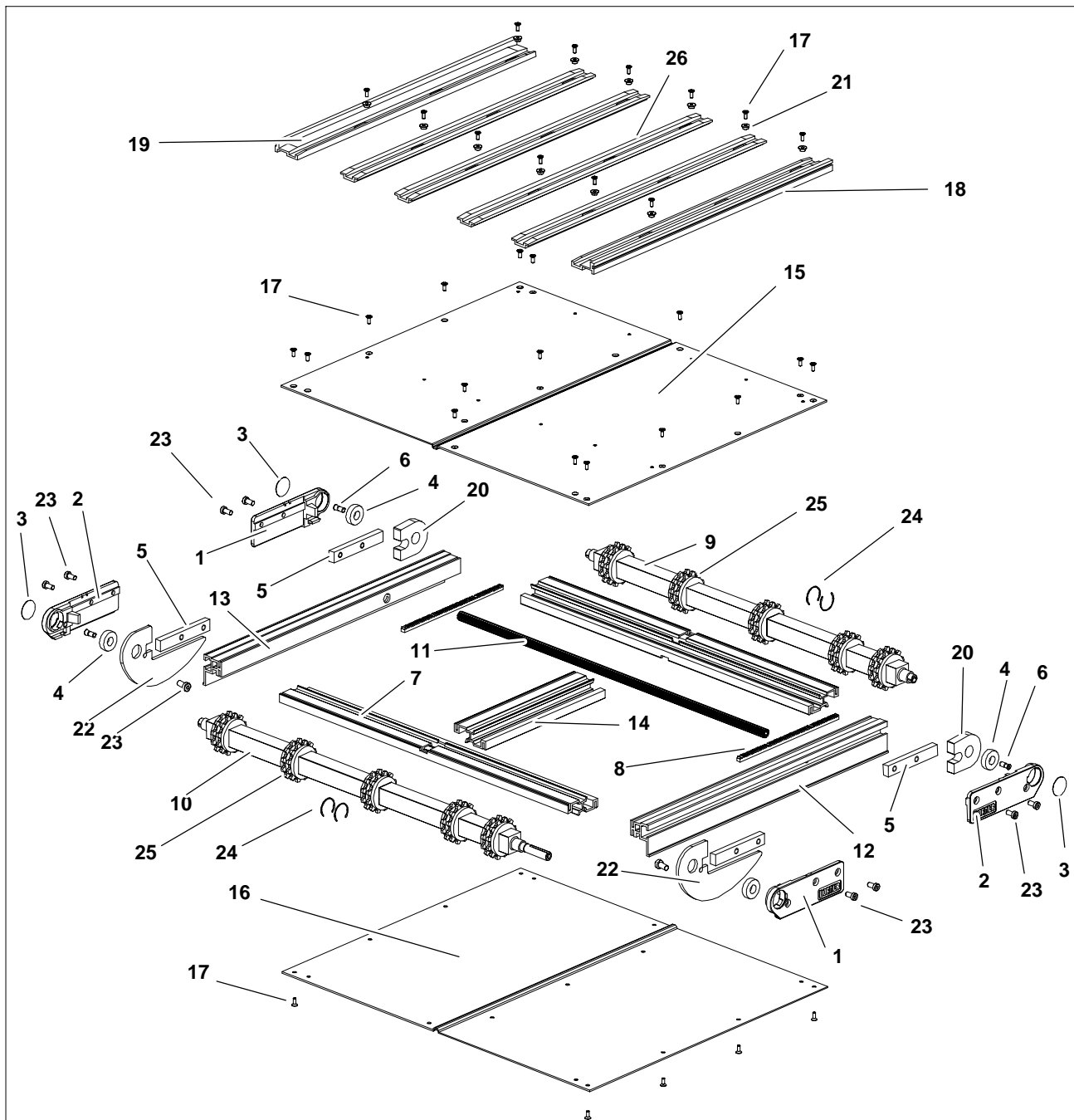

Item	Part Number	Description
1	240325	Head Plate LH
2	240326	Head Plate RH
3	240327	Bearing Cover Disk
4	240328	Bearing
5	240329	Tension Slide Bar
6	240330	Taper Screw
7	240417	Center Rail Cross Support 18" (457mm)
	240419	Center Rail Cross Support 24" (610mm)
8	240420	Rack Gear 14.5 PA x 24 P

9	245518	18" MPB Idler Spindle
	245524	24" MPB Idler Spindle
10	245718	18" MPB Drive Spindle
	245724	24" MPB Drive Spindle
11	203018M	Pinion Gear 18" (457mm)
	203024M	Pinion Gear 24" (610mm)
12	See Chart Below	Side Rail RH 8–24" Wide (203–610mm)
13	See Chart Below	Side Rail LH 8–24" Wide (203–610mm)
14	See Chart Below	Center Rail 8–12" Wide (203–305mm)

Service Parts

15	See Chart Below	Bed Plate Top
16	See Chart Below	Bed Plate Bottom
17	807-1105	Torx, Flat Head M4 x 10mm
18	245827-LLLL	LH Outer Wear Strip – UHMW
	245828-LLLL	LH Outer Wear Strip – Antistat
19	245829-LLLL	RH Outer Wear Strip – UHMW
	245830-LLLL	RH Outer Wear Strip – Antistat
20	245850	Pinch Guard
21	245854	Screw Sleeve
22	245858	Sag Guard
23	920692M	Socket Head Screw M6 x 12mm
24	807-1108	Retaining Ring
25	807-1106	MPB Spindle Sprocket
26	245831-LLLL	Center Wear Strips – UHMW
	245832-LLLL	Center Wear Strips – Antistat

Item 12: Side Rail RH 18" and 24" Wide (457mm & 610mm)	
Length	Part Number
2' (610mm)	240412-01908
3' (914mm)	240412-03108
4' (1219mm)	240412-04308
5' (1524mm)	240412-05508
6' (1829mm)	240412-06708
7' (2134mm)	240412-07908
8' (2438mm)	240412-09108
9' (2743mm)	240412-10308
10' (3048mm)	240412-11508
11' (3353mm)	240412-12708
12' (3658mm)	240412-13908
13' (3962mm)	240412-07200 240412-07908
14' (4267mm)	240412-07200 240412-09108
15' (4572mm)	240412-07200 240412-10308
16' (4877mm)	240412-07200 240412-11508
17' (5182mm)	240412-07200 240412-12708
18' (5486mm)	240412-07200 240412-13908
19' (5791mm)	240412-07908 240412-13908
20' (6096mm)	240412-09108 240412-13908
21' (6401mm)	240412-10308 240412-13908
22' (6706mm)	240412-11508 240412-13908
23' (7010mm)	240412-12708 240412-13908
24' (7315mm)	240412-13908 240412-13908
25' (7620mm)	240412-07908 240412-07200 240412-13908
26' (7925mm)	240412-09108 240412-07200 240412-13908
27' (8230mm)	240412-10308 240412-07200 240412-13908

28' (8534mm)	240412-11508 240412-07200 240412-13908
29' (8839mm)	240412-12708 240412-07200 240412-13908
30' (9144mm)	240412-13908 240412-07200 240412-13908

Item 13: Side Rail LH 18" and 24" Wide (457mm & 610mm)	
Length	Part Number
2' (610mm)	240413-01908
3' (914mm)	240413-03108
4' (1219mm)	240413-04308
5' (1524mm)	240413-05508
6' (1829mm)	240413-06708
7' (2134mm)	240413-07908
8' (2438mm)	240413-09108
9' (2743mm)	240413-10308
10' (3048mm)	240413-11508
11' (3353mm)	240413-12708
12' (3658mm)	240413-13908
13' (3962mm)	240413-07200 240413-07908
14' (4267mm)	240413-07200 240413-09108
15' (4572mm)	240413-07200 240413-10308
16' (4877mm)	240413-07200 240413-11508
17' (5182mm)	240413-07200 240413-12708
18' (5486mm)	240413-07200 240413-13908
19' (5791mm)	240413-07908 240413-13908
20' (6096mm)	240413-09108 240413-13908
21' (6401mm)	240413-10308 240413-13908
22' (6706mm)	240413-11508 240413-13908
23' (7010mm)	240413-12708 240413-13908
24' (7315mm)	240413-13908 240413-13908
25' (7620mm)	240413-07908 240413-07200 240413-13908
26' (7925mm)	240413-09108 240413-07200 240413-13908
27' (8230mm)	240413-10308 240413-07200 240413-13908
28' (8534mm)	240413-11508 240413-07200 240413-13908
29' (8839mm)	240413-12708 240413-07200 240413-13908
30' (9144mm)	240413-13908 240413-07200 240413-13908

Item 14: Center Rail 18" and 24" Wide (457mm-610mm)	
Length	Part Number
2' (610mm)	240414-00998
3' (914mm)	240414-02198
4' (1219mm)	240414-03398
5' (1524mm)	240414-04498
6' (1829mm)	240414-05798

Service Parts

7' (2134mm)	240414-06998
8' (2438mm)	240414-08198
9' (2743mm)	240414-09398
10' (3048mm)	240414-10598
11' (3353mm)	240414-11798
12' (3658mm)	240414-12998
13' (3962mm)	240414-06700 240414-06998
14' (4267mm)	240414-06700 240414-08198
15' (4572mm)	240414-06700 240414-09398
16' (4877mm)	240414-06700 240414-10598
17' (5182mm)	240414-06700 240414-11798
18' (5486mm)	240414-06700 240414-12998
19' (5791mm)	240414-06998 240414-12998
20' (6096mm)	240414-08198 240414-12998
21' (6401mm)	240414-09398 240414-12998
22' (6706mm)	240414-10598 240414-12998
23' (7010mm)	240414-11798 240414-12998
24' (7315mm)	240414-12998 240414-12998
25' (7620mm)	240414-06998 240414-06700 240414-12998
26' (7925mm)	240414-08198 240414-06700 240414-12998
27' (8230mm)	240414-09398 240414-06700 240414-12998
28' (8534mm)	240414-10598 240414-06700 240414-12998
29' (8839mm)	240414-11798 240414-06700 240414-12998
30' (9144mm)	240414-12998 240414-06700 240414-12998

Item 15: Bed Plate Top	
Length	Part Number
2' (610mm)	2405WW-01904
3' (914mm)	2405WW-03104
4' (1219mm)	2405WW-04304
5' (1524mm)	2405WW-05504
6' (1829mm)	2405WW-06704
7' (2134mm)	2405WW-07904
8' (2438mm)	2405WW-09104
9' (2743mm)	2405WW-10304
10' (3048mm)	2405WW-11504
11' (3353mm)	2405WW-12704
12' (3658mm)	2405WW-13904
13' (3962mm)	2405WW-07196 2405WW-07904
14' (4267mm)	2405WW-07196 2405WW-09104
15' (4572mm)	2405WW-07196 2405WW-10304
16' (4877mm)	2405WW-07196 2405WW-11504
17' (5182mm)	2405WW-07196 2405WW-12704

18' (5486mm)	2405WW-07196 2405WW-13904
19' (5791mm)	2405WW-07904 2405WW-13904
20' (6096mm)	2405WW-09104 2405WW-13904
21' (6401mm)	2405WW-10304 2405WW-13904
22' (6706mm)	2405WW-11504 2405WW-13904
23' (7010mm)	2405WW-12704 2405WW-13904
24' (7315mm)	2405WW-13904 2405WW-13904
25' (7620mm)	2405WW-07904 2405WW-07196 2405WW-13904
26' (7925mm)	2405WW-09104 2405WW-07196 2405WW-13904
27' (8230mm)	2405WW-10304 2405WW-07196 2405WW-13904
28' (8534mm)	2405WW-11504 2405WW-07196 2405WW-13904
29' (8839mm)	2405WW-12704 2405WW-07196 2405WW-13904
30' (9144mm)	2405WW-13904 2405WW-07196 2405WW-13904
WW = Conveyor Width reference: 18, 24	

Item 16: Bed Plate Bottom	
Length	Part Number
2' (610mm)	2405WW-01904
3' (914mm)	2405WW-03104
4' (1219mm)	2405WW-04304
5' (1524mm)	2405WW-05504
6' (1829mm)	2405WW-06704
7' (2134mm)	2405WW-07904
8' (2438mm)	2405WW-09104
9' (2743mm)	2405WW-10304
10' (3048mm)	2405WW-11504
11' (3353mm)	2405WW-12704
12' (3658mm)	2405WW-13904
13' (3962mm)	2405WW-07196 2405WW-07904
14' (4267mm)	2405WW-07196 2405WW-09104
15' (4572mm)	2405WW-07196 2405WW-10304
16' (4877mm)	2405WW-07196 2405WW-11504
17' (5182mm)	2405WW-07196 2405WW-12704
18' (5486mm)	2405WW-07196 2405WW-13904
19' (5791mm)	2405WW-07904 2405WW-13904
20' (6096mm)	2405WW-09104 2405WW-13904
21' (6401mm)	2405WW-10304 2405WW-13904
22' (6706mm)	2405WW-11504 2405WW-13904
23' (7010mm)	2405WW-12704 2405WW-13904
24' (7315mm)	2405WW-13904 2405WW-13904
25' (7620mm)	2405WW-07904 2405WW-07196 2405WW-13904

26' (7925mm)	2405WW-09104 2405WW-07196 2405WW-13904
27' (8230mm)	2405WW-10304 2405WW-07196 2405WW-13904
28' (8534mm)	2405WW-11504 2405WW-07196 2405WW-13904

29' (8839mm)	2405WW-12704 2405WW-07196 2405WW-13904
30' (9144mm)	2405WW-13904 2405WW-07196 2405WW-13904
WW = Conveyor Width reference: 18, 24	

Return Wear Strip Assembly – 2' (610mm) and 3' (914mm) Long

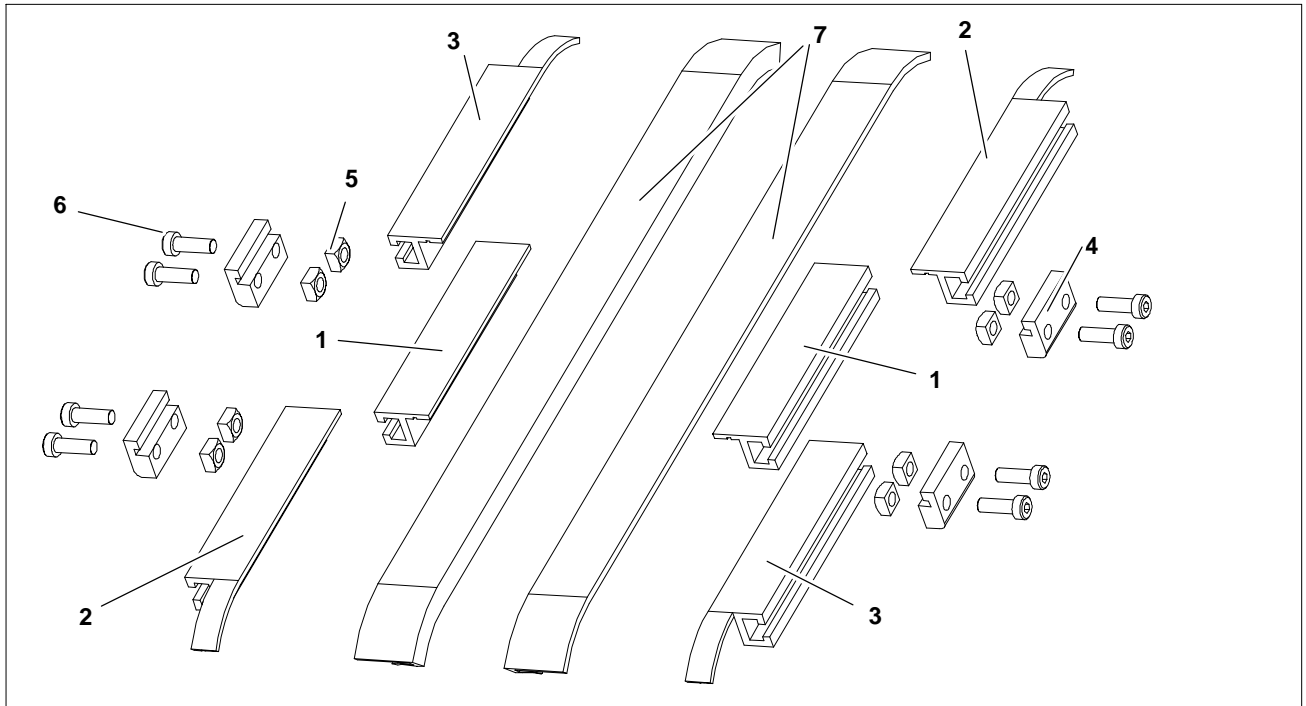

Item	Part Number	Description
1	246075-0042	2' (610mm) Return Support Extrusion
	246075-0162	3' (914mm) Return Support Extrusion
2	246078	LH Lead-in Return Support
3	246079	RH Lead-in Return Support

4	246080	MPB Return Connector Clip
5	807-920	M6 Square Nut
6	920693M	Scr, Cap Low Head M6 1.0x16mm
7	807-1102	Bottom Wear Strip – UHMW
	807-1103	Bottom Wear Strip – Antistat

Service Parts

Return Wear Strip Assembly – 4' (1219mm) to 30' (9144mm) Length

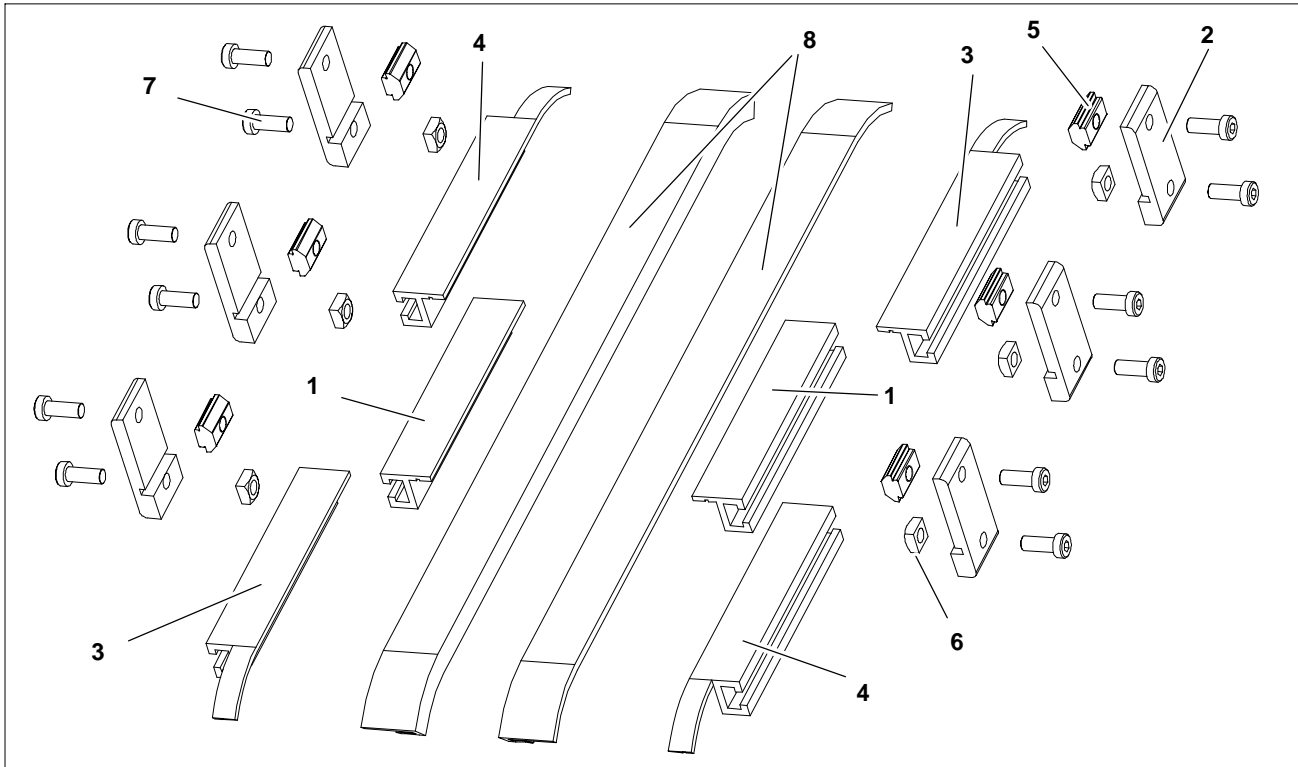

Item	Part Number	Description
1	See Chart Below	Return Support Extrusion
2	246076	MPB Return Clip
3	246078	LH Lead-in Return Support
4	246079	RH Lead-in Return Support
5	639971M	M6 Drop In Tee Bar
6	807-920	M6 Square Nut
7	920693M	Scr, Cap Low Head M6 1.0x16mm
8	807-1102	Bottom Wear Strip – UHMW
9	807-1103	Bottom Wear Strip – Antistat

Item 1: MPB Return Support Extrusion	
Length	Part Number
4' (1219mm)	246075-02825
5' (1524mm)	246075-04025
6' (1829mm)	246075-05225
7' (2134mm)	246075-06425
8' (2438mm)	246075-07625
9' (2743mm)	246075-08825
10' (3048mm)	246075-10025

11' (3353mm)	246075-11225
12' (3658mm)	246075-12425
13' (3962mm)	246075-07387; 246075-0519
14' (4267mm)	246075-08587; 246075-0519
15' (4572mm)	246075-09787; 246075-0519
16' (4877mm)	246075-10987; 246075-0519
17' (5182mm)	246075-12187; 246075-0519
18' (5486mm)	246075-13387; 246075-0519
19' (5791mm)	246075-07387; 246075-1119
20' (6096mm)	246075-08587; 246075-1119
21' (6401mm)	246075-09787; 246075-1119
22' (6706mm)	246075-10987; 246075-1119
23' (7011mm)	246075-12187; 246075-1119
24' (7315mm)	246075-13387; 246075-1119
25' (7620mm)	246075-07387; 246075-0519; 246075-1200
26' (7925mm)	246075-08587; 246075-0519; 246075-1201
27' (8230mm)	246075-09787; 246075-0519; 246075-1202
28' (8534mm)	246075-10987; 246075-0519; 246075-1203
29' (8839mm)	246075-12187; 246075-0519; 246075-1204
30' (9144mm)	246075-13387; 246075-0519; 246075-1205

-04 2.3" (60mm) Aluminum Side

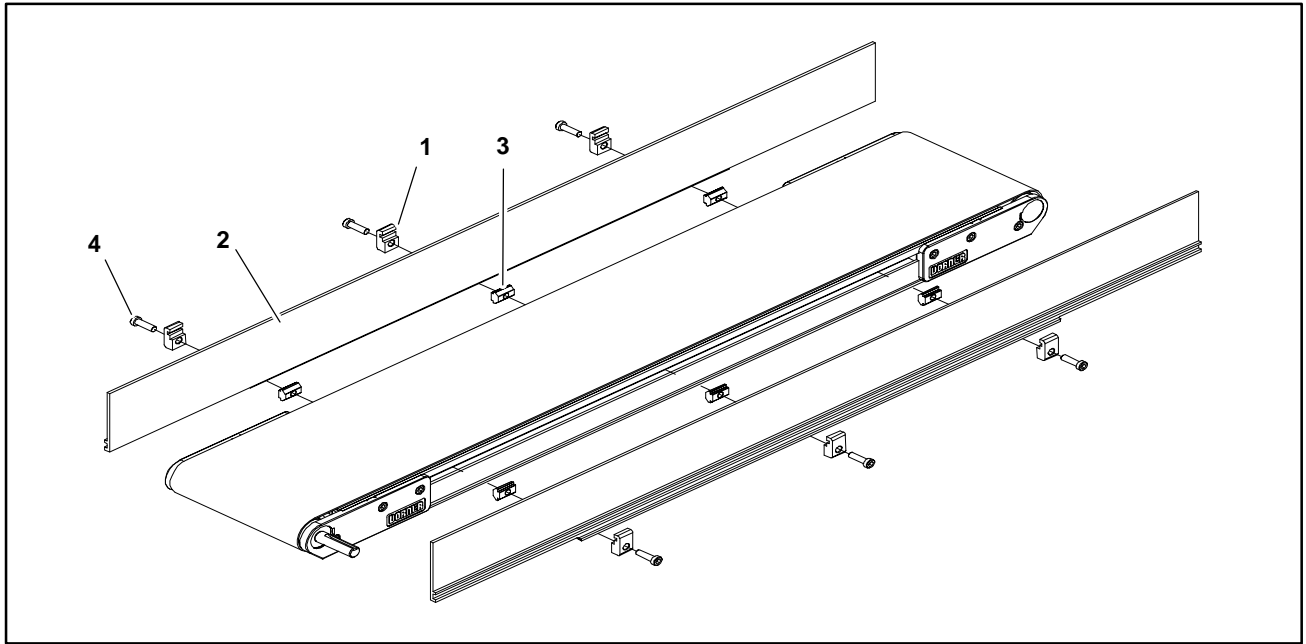

Item	Part Number	Description
1	200121	Guide Retaining Clip
2	See Chart Below	MPB Guide 2.3" (60mm) HS
3	200695P	Single Drop-in Tee Bar
4	920694M	Socket Head Screw M6 x 20mm

Item 2: MPB Guide 2.3"(60mm) HS 2'(610mm) to 24'(7315mm)			
Length		End Guide	End Guide
2' (610mm)	Left Hand	280403-02400	N/A
	Right Hand	280403-02400	N/A
3' (914mm)	Left Hand	280403-03600	N/A
	Right Hand	280403-03600	N/A
4' (1219mm)	Left Hand	280403-04800	N/A
	Right Hand	280403-04800	N/A
5' (1524mm)	Left Hand	280403-06000	N/A
	Right Hand	280403-06000	N/A
6' (1829mm)	Left Hand	280403-07200	N/A
	Right Hand	280403-07200	N/A
7' (2134mm)	Left Hand	280403-08400	N/A
	Right Hand	280403-08400	N/A
8' (2438mm)	Left Hand	280403-09600	N/A
	Right Hand	280403-09600	N/A
9' (2743mm)	Left Hand	280403-10800	N/A
	Right Hand	280403-10800	N/A
10' (3048mm)	Left Hand	280403-12000	N/A
	Right Hand	280403-12000	N/A
11' (3353mm)	Left Hand	280403-13200	N/A

12' (3658mm)	Right Hand	280403-13200	N/A
	Left Hand	280403-14400	N/A
13' (3962mm)	Right Hand	280403-14400	N/A
	Left Hand	280401-07500	280401-08100
14' (4267mm)	Right Hand	280402-07500	280402-08100
	Left Hand	280401-07500	280401-09300
15' (4572mm)	Right Hand	280402-07500	280402-09300
	Left hand	280401-07500	280401-10500
16' (4877mm)	Right Hand	280402-07500	280402-10500
	Left Hand	280401-07500	280401-11700
17' (5182mm)	Right Hand	280402-07500	280402-11700
	Left Hand	280401-07500	280401-12900
18' (5486mm)	Right Hand	280402-07500	280402-12900
	Left Hand	280401-07500	280401-14100
19' (5791mm)	Right Hand	280402-07500	280402-14100
	Left Hand	280401-14700	280401-08100
20' (6096mm)	Right Hand	280402-14700	280402-08100
	Left Hand	280401-14700	280401-09300
21' (6401mm)	Right Hand	280402-14700	280402-09300
	Left hand	280401-14700	280401-10500
22' (6706mm)	Right Hand	280402-14700	280402-10500
	Left Hand	280401-14700	280401-11700
23' (7010mm)	Right Hand	280402-14700	280402-11700
	Left Hand	280401-14700	280401-12900
24' (7315mm)	Right Hand	280402-14700	280402-12900
	Left Hand	280401-14700	280401-14100
	Right Hand	280402-14700	280402-14100

Service Parts

Item 2: MPB Guide 2.3" (60mm) HS 25' (7620mm) to 30' (9144mm)				
Length		End Guide	End Guide	Center
25' (7620mm)	Left Hand	280401-07500	280401-08100	200601P-14400
	Right Hand	280402-07500	280402-08100	200601P-14400
26' (7925mm)	Left Hand	280401-07500	280401-09300	200601P-14400
	Right Hand	280402-07500	280402-09300	200601P-14400
27' (8230mm)	Left Hand	280401-07500	280401-10500	200601P-14400
	Right Hand	280402-07500	280402-10500	200601P-14400
28' (8534mm)	Left Hand	280401-07500	280401-11700	200601P-14400
	Right Hand	280402-07500	280402-11700	200601P-14400
29' (8839mm)	Left Hand	280401-07500	280401-12900	200601P-14400
	Right Hand	280402-07500	280402-12900	200601P-14400
30' (9144mm)	Left Hand	280401-07500	280401-14100	200601P-14400
	Right Hand	280402-07500	280402-14100	200601P-14400

-05 1.5" (38mm) Aluminum Side

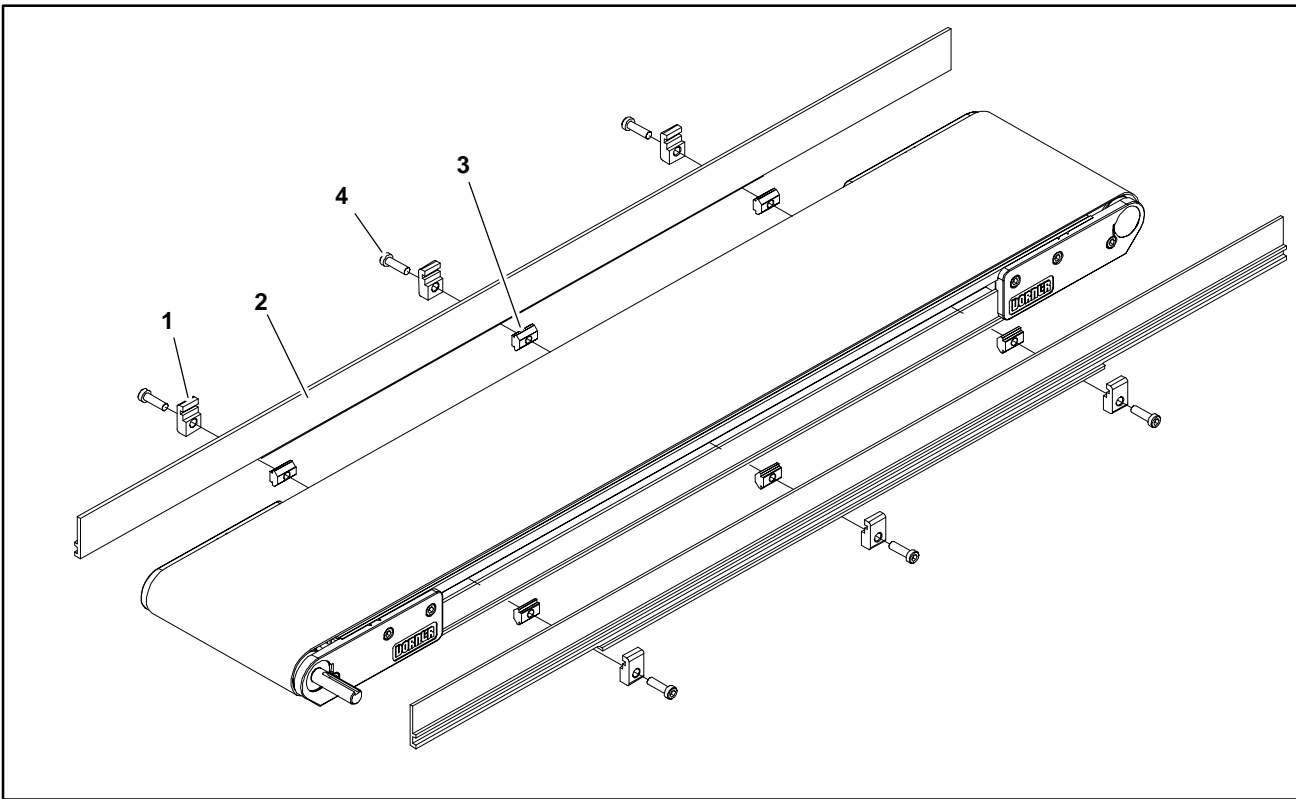

Item	Part Number	Description
1	200121	Guide Retaining Clip
2	See Chart Below	MPB Guide .5" (13mm) HS
3	639971M	Single Drop-in Tee Bar
4	920694M	Socket Head Screw M6 x 20mm

Item 2: 2200 Guide .5" (13mm) HS			
Length		End Guide	End Guide
2' (610mm)	Left Hand	280503-0240 0	N/A
	Right Hand	280503-0240 0	N/A

3' (914mm)	Left Hand	280503-0360 0	N/A
	Right Hand	280503-0360 0	N/A
4' (1219mm)	Left Hand	280503-0480 0	N/A
	Right Hand	280503-0480 0	N/A
5' (1524mm)	Left Hand	280503-0600 0	N/A
	Right Hand	280503-0600 0	N/A
6' (1829mm)	Left Hand	280503-0720 0	N/A

Service Parts

	Right Hand	280503-0720 0	N/A
7' (2134mm)	Left Hand	280503-0840 0	N/A
	Right Hand	280503-0840 0	N/A
8' (2438mm)	Left Hand	280503-0960 0	N/A
	Right Hand	280503-0960 0	N/A
9' (2743mm)	Left Hand	280503-1080 0	N/A
	Right Hand	280503-1080 0	N/A
10' (3048mm)	Left Hand	280503-1200 0	N/A
	Right Hand	280503-1200 0	N/A
11' (3353mm)	Left Hand	280503-1320 0	N/A
	Right Hand	280503-1320 0	N/A
12' (3658mm)	Left Hand	280503-1440 0	N/A
	Right Hand	280503-1440 0	N/A
13' (3962mm)	Left Hand	280501-0750 0	280501-0810 0
	Right Hand	280502-0750 0	280502-0810 0
14' (4267mm)	Left Hand	280501-0750 0	280501-0930 0
	Right Hand	280502-0750 0	280502-0930 0
15' (4572mm)	Left hand	280501-0750 0	280501-1050 0
	Right Hand	280502-0750 0	280502-1050 0

16' (4877mm)	Left Hand	280501-0750 0	280501-1170 0
	Right Hand	280502-0750 0	280502-1170 0
17' (5182mm)	Left Hand	280501-0750 0	280501-1290 0
	Right Hand	280502-0750 0	280502-1290 0
18' (5486mm)	Left Hand	280501-0750 0	280501-1410 0
	Right Hand	280502-0750 0	280502-1410 0
19' (mm)	Left Hand	280501-1470 0	280501-0810 0
	Right Hand	280502-1470 0	280502-0810 0
20' (mm)	Left Hand	280501-1470 0	280501-0930 0
	Right Hand	280502-1470 0	280502-0930 0
21' (mm)	Left hand	280501-1470 0	280501-1050 0
	Right Hand	280502-1470 0	280502-1050 0
22' (mm)	Left Hand	280501-1470 0	280501-1170 0
	Right Hand	280502-1470 0	280502-1170 0
23' (mm)	Left Hand	280501-1470 0	280501-1290 0
	Right Hand	280502-1470 0	280502-1290 0
24' (mm)	Left Hand	280501-1470 0	280501-1410 0
	Right Hand	280502-1470 0	280502-1410 0

Item 2: MPB Guide .5" (13mm) HS 25' (7620mm) to 30' (9144mm)				
Length		End Guide	End Guide	Center
25' (7620mm)	Left Hand	280501-07500	280501-08100	200750P-14400
	Right Hand	280502-07500	280502-08100	200750P-14400
26' (7925mm)	Left Hand	280501-07500	280501-09300	200750P-14400
	Right Hand	280502-07500	280502-09300	200750P-14400
27' (8230mm)	Left Hand	280501-07500	280501-10500	200750P-14400
	Right Hand	280502-07500	280502-10500	200750P-14400
28' (8534mm)	Left Hand	280501-07500	280501-11700	200750P-14400
	Right Hand	280502-07500	280502-11700	200750P-14400
29' (8839mm)	Left Hand	280501-07500	280501-12900	200750P-14400
	Right Hand	280502-07500	280502-12900	200750P-14400
30' (9144mm)	Left Hand	280501-07500	280501-14100	200750P-14400
	Right Hand	280502-07500	280502-14100	200750P-14400

Service Parts

-13 Adjustable Guiding

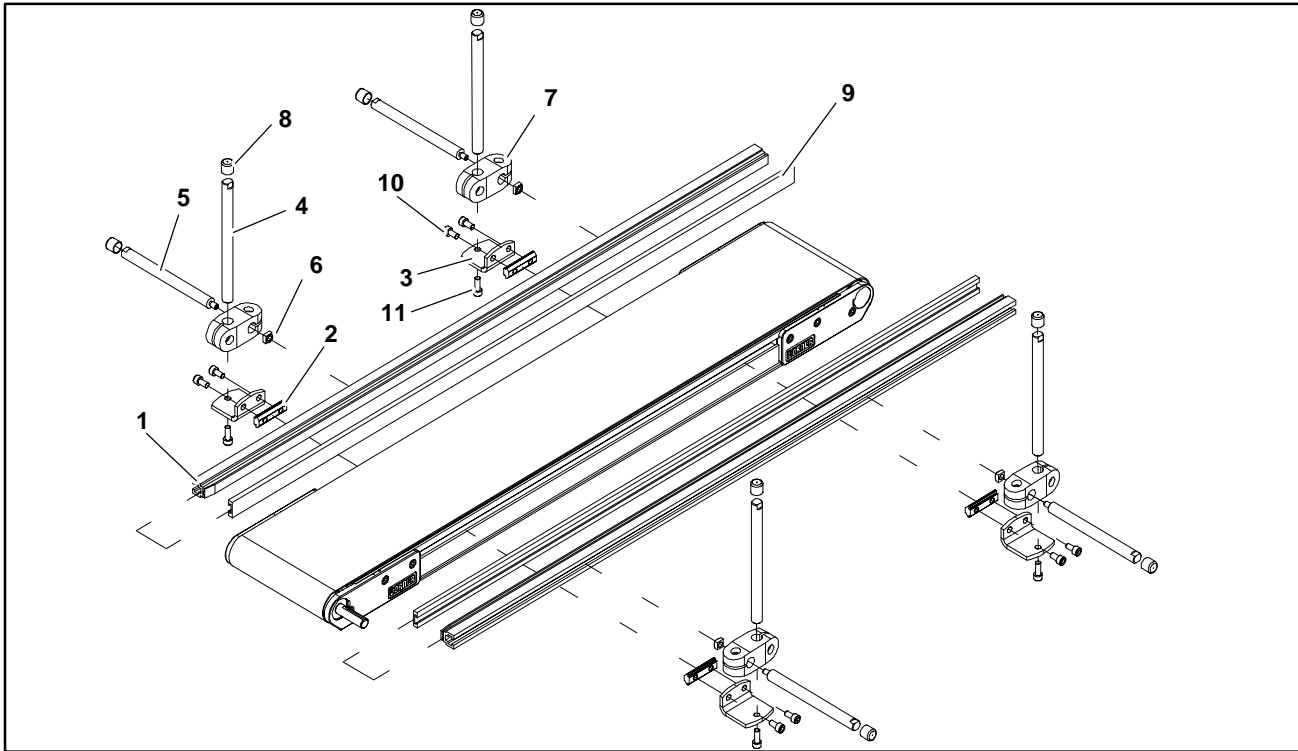

Item	Part Number	Description
1	See Chart Below	Aluminum Profile Guide
2	200830M	Drop-In Tee Bar
3	202004	Mounting Bracket
4	202027M	Guide Mounting Shaft Vertical
5	202028M	Guide Mounting Shaft Horizontal
6	674175MP	Square Nut
7	807-652	Cross Block
8	807-948	Vinyl Shaft Cap
9	614068P	Flat Extruded Guide (per foot)
10	920612M	Socket Head Screw M6 x 12mm
11	920616M	Socket Head Screw M6 x 16mm

Item 2: MPB Aluminum Profile Guide			
Length	End Guide	Middle Guide	End Guide
2' (610mm)	202983	N/A	N/A
3' (914mm)	202984	N/A	N/A
4' (1219mm)	202985	N/A	N/A
5' (1524mm)	202986	N/A	N/A
6' (1829mm)	202987	N/A	N/A
7' (2134mm)	202988	N/A	N/A
8' (2438mm)	202989	N/A	N/A

9' (2743mm)	202990	N/A	N/A
10' (3048mm)	202991	N/A	N/A
11' (3353mm)	202992	N/A	N/A
12' (3658mm)	202993	N/A	N/A
13' (3962mm)	202988	202987	N/A
14' (4267mm)	202989	202987	N/A
15' (4572mm)	202990	202987	N/A
16' (4877mm)	202991	202987	N/A
17' (5182mm)	202992	202987	N/A
18' (5486mm)	202993	202987	N/A
19' (5791mm)	202988	202993	N/A
20' (6096mm)	202989	202993	N/A
21' (6401mm)	202990	202993	N/A
22' (6706mm)	202991	202993	N/A
23' (7010mm)	202992	202993	N/A
24' (7315mm)	202993	202993	N/A
25' (7620mm)	202988	202993	202987
26' (7925mm)	202989	202993	202987
27' (8230mm)	202990	202993	202987
28' (8534mm)	202991	202993	202987
29' (8839mm)	202992	202993	202987
30' (9144mm)	202993	202993	202987

2" (51mm) Cleated Guiding

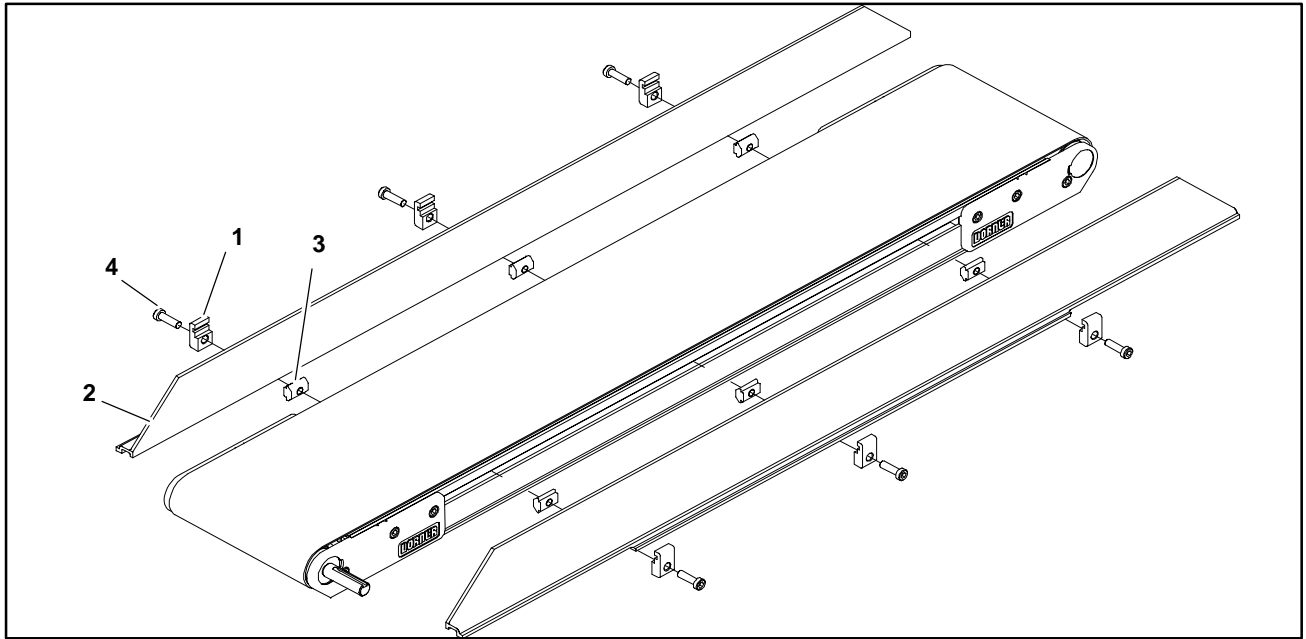

Item	Part Number	Description
1	200121	Guide Retaining Clip
2	See Chart Below	2200 Guide 2.3" Cleated
3	639971M	Drop-In Tee Bar
4	920694M	Socket Head Screw M6 x 20mm

Item 2: MPB Cleated Guide			
Length	End Guide	Middle Guide	End Guide
2' (610mm)	246051-01070	N/A	246052-01070
3' (914mm)	246051-01670	N/A	246052-01670
4' (1219mm)	246051-02270	N/A	246052-02270
5' (1524mm)	246051-02870	N/A	246052-02870
6' (1829mm)	246051-03470	N/A	246052-03470
7' (2134mm)	246051-04070	N/A	246052-04070
8' (2438mm)	246051	N/A	246052
9' (2743mm)	246051-03513	246050-03513	246052-03513
10' (3048mm)	246051-03913	246050-03913	246052-03913
11' (3353mm)	246051	246050-03600	246052
12' (3658mm)	246051	246050-04800	246052
13' (3962mm)	246051	246050-03300 246050-02700	246052
14' (4267mm)	246051	246050-04500 246050-02700	246052
15' (4572mm)	246051	246050-05700 246050-02700	246052
16' (4877mm)	246051	246050-06900 246050-02700	246052

17' (5182mm)	246051	246050-08100 246050-02700	246052
18' (5486mm)	246051	246050-09300 246050-02700	246052
19' (5791mm)	246051	246050-03300 246050-09900	246052
20' (6096mm)	246051	246050-04500 246050-09900	246052
21' (6401mm)	246051	246050-05700 246050-09900	246052
22' (6706mm)	246051	246050-06900 246050-09900	246052
23' (7010mm)	246051	246050-08100 246050-09900	246052
24' (7315mm)	246051	246050-09300 246050-09900	246052
25' (7620mm)	246051	246050-09300 246050-09900 246050-02700	246052
26' (7925mm)	246051	246050-03300 246050-14400 246050-02700	246052
27' (8230mm)	246051	246050-04500 246050-14400 246050-02700	246052
28' (8534mm)	246051	246050-05700 246050-14400 246050-02700	246052
29' (8839mm)	246051	246050-06900 246050-14400 246050-02700	246052
30' (9144mm)	246051	246050-08100 246050-14400 246050-02700	246052

Service Parts

Flat Belt Mounting Brackets

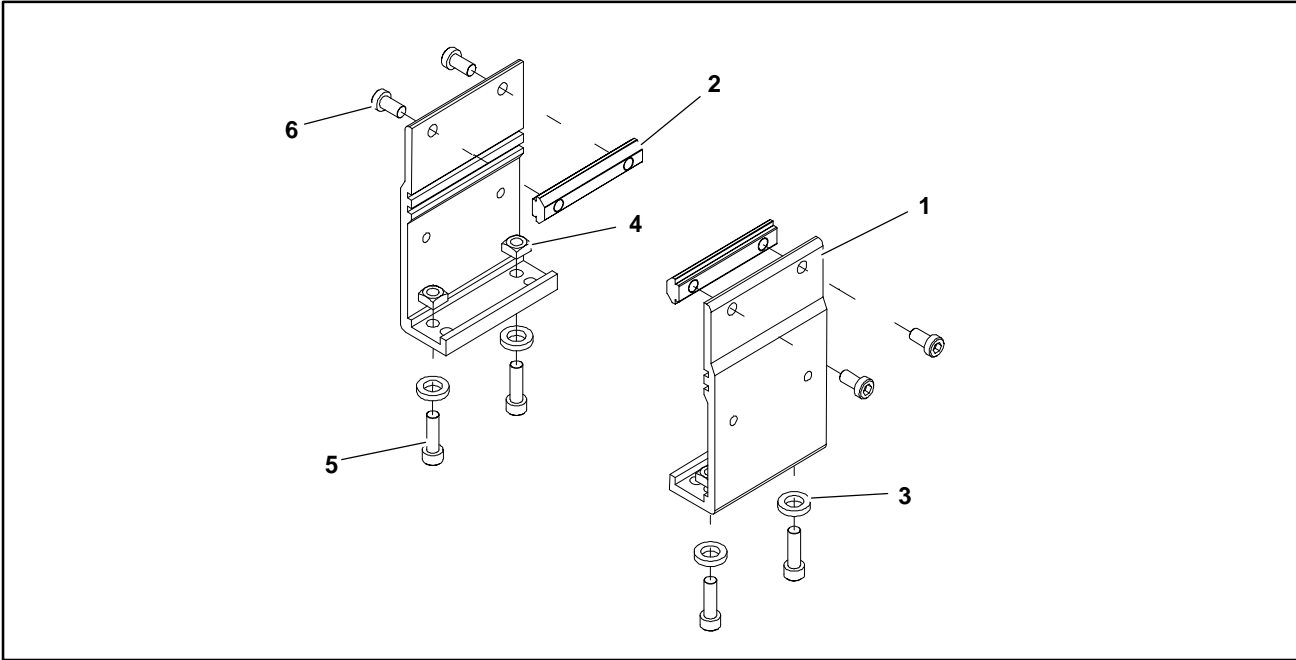

Item	Part Number	Description
1	240831	Stand Mount
2	300150M	Drop-In Tee Bar
3	605279P	Washer

4	807-920	Square Nut M6 5mm x 10mm
5	920620M	Socket Head Screw M6 x 20mm
6	920692M	Socket Head Screw M6 x 12mm

Cleated Belt Mounting Brackets

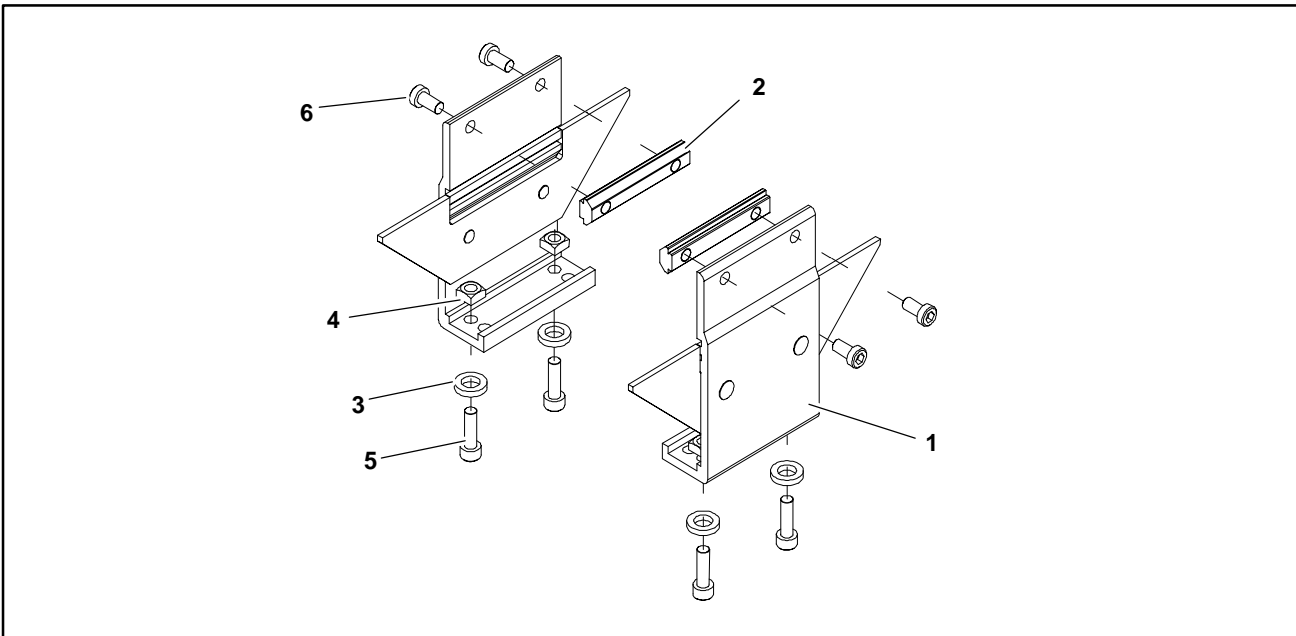

Item	Part Number	Description
1	240836	Cleated Mounting Assembly
2	300150M	Drop-In Tee Bar
3	605279P	Washer

4	807-920	Square Nut M6 5mm x 10mm
5	920620M	Socket Head Screw M6 x 20mm
6	920692M	Socket Head Screw M6 x 12mm

Flat Belt Mounting Brackets for 2' (610mm) Conveyors

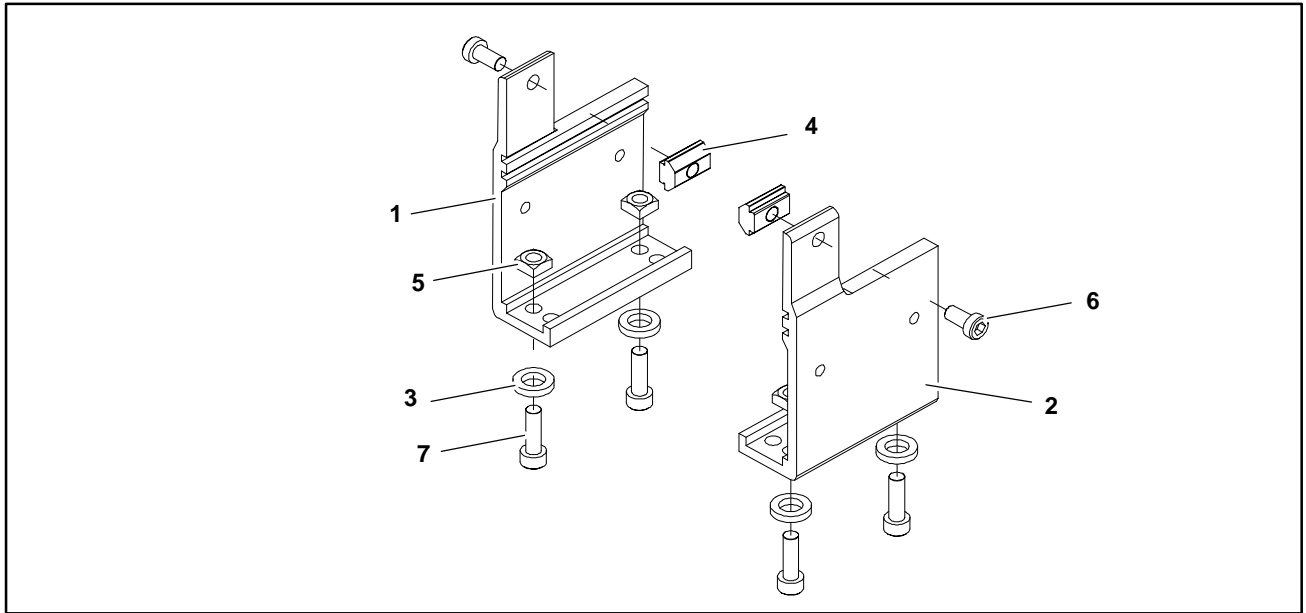

Item	Part Number	Description
1	240833	Stand Mount, LH 2' (610mm)
2	240834	Stand Mount, RH 2' (610mm)
3	605279P	Washer

4	639971M	Drop-In Tee Bar
5	807-920	Square Nut M6 5mm x 10mm
6	920620M	Socket Head Screw M6 x 20mm
7	920692M	Socket Head Screw M6 x 12mm

Cleated Belt Mounting Brackets for 2' (610mm) Conveyors

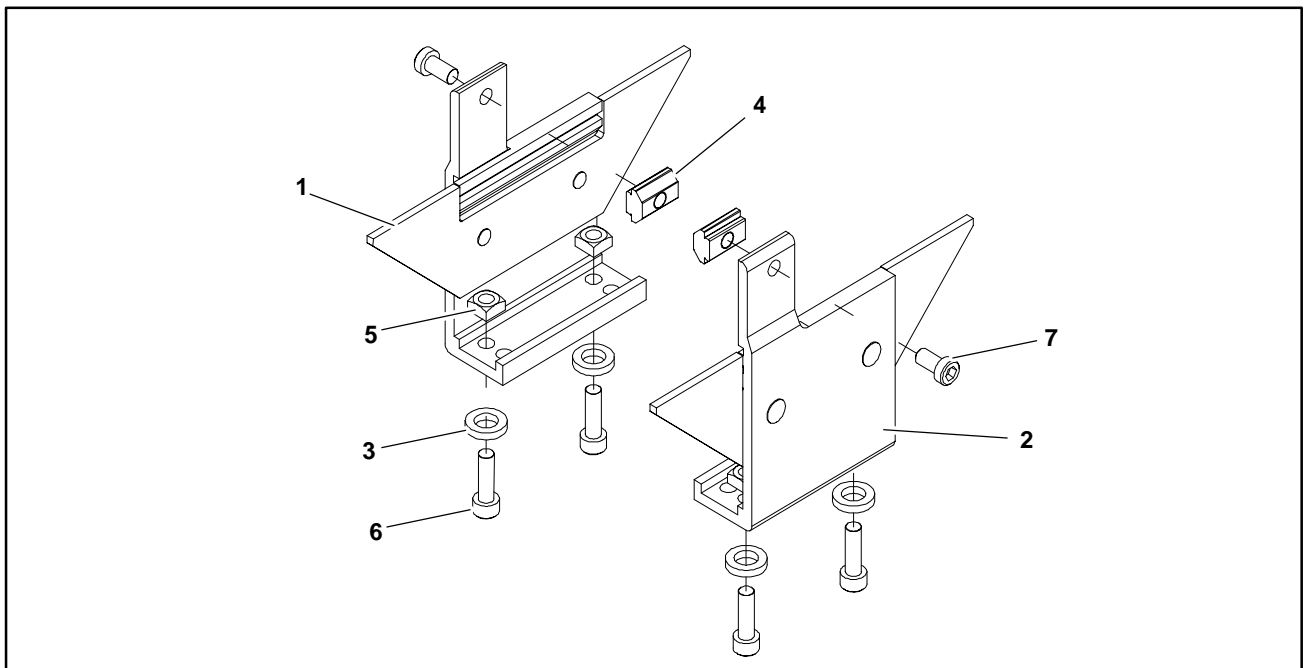

Item	Part Number	Description
1	240852	Cleated Stand Bracket Assembly LH 2' (610mm) Conveyor
2	240853	Cleated Stand Bracket Assembly RH 2' (610mm) Conveyor
3	605279P	Washer

4	639971M	Drop-In Tee Bar
5	807-920	Square Nut M6 5mm x 10mm
6	920620M	Socket Head Screw M6 x 20mm
7	920692M	Socket Head Screw M6 x 12mm

Service Parts

Connecting Assembly without Stand Mount

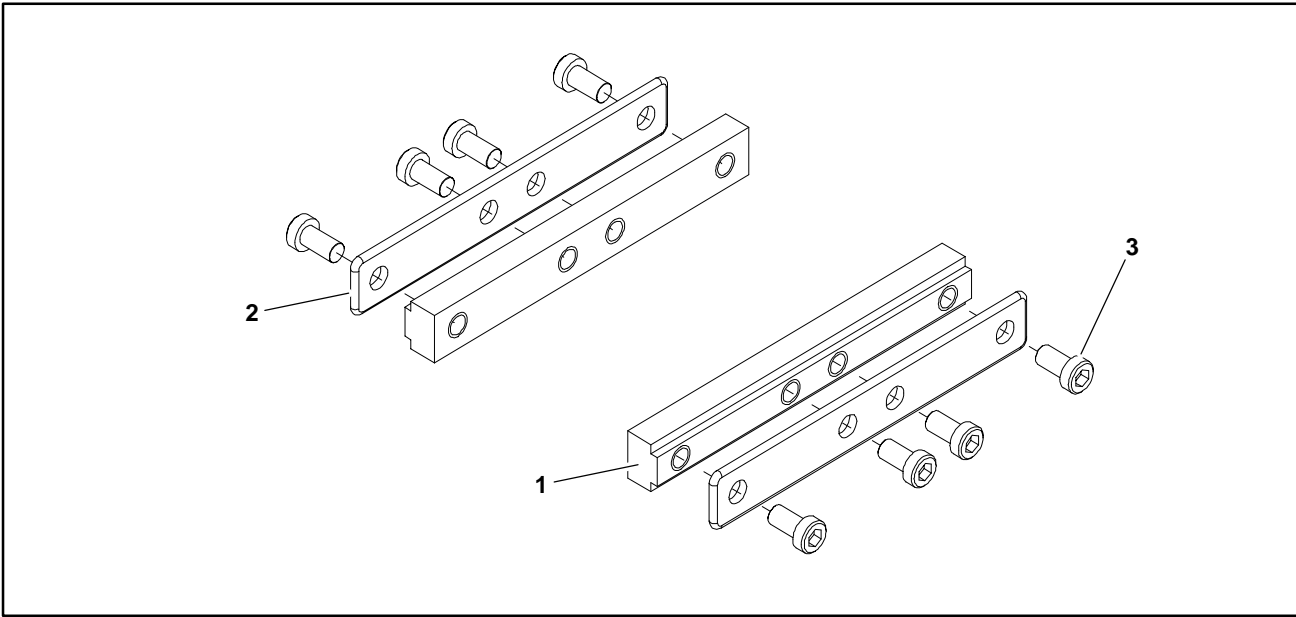

Item	Part Number	Description
1	240331	Frame Bar Connector

2	300153M	Intermediate Clamp Plate
3	920692M	Socket Head Screw M6 x 12mm

Flat Belt Connecting Assembly with Stand Mount

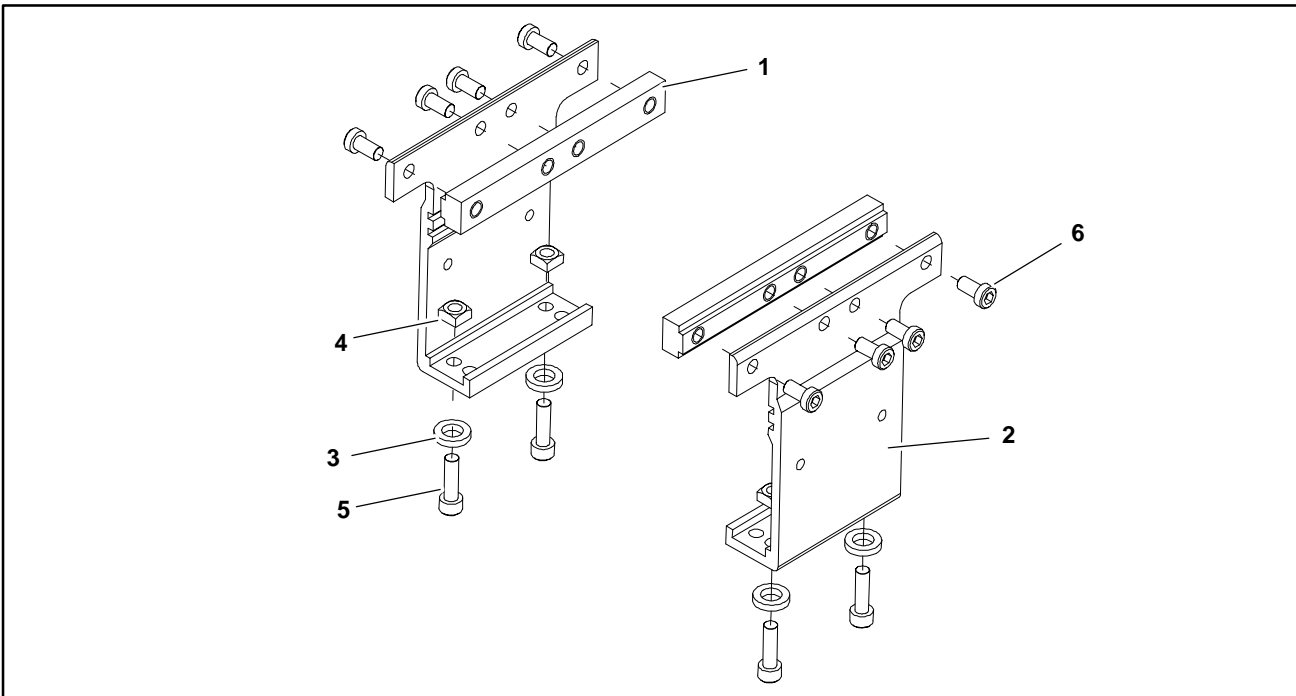

Item	Part Number	Description
1	240331	Frame Connector Bar
2	240837	Stand Mount Joint
3	605279P	Washer

4	807-920	Square Nut M6 5mm x 10mm
5	920620M	Socket Head Screw M6 x 20mm
6	920692M	Socket Head Screw M6 x 12mm

Cleated Belt Connecting Assembly with Stand Mount

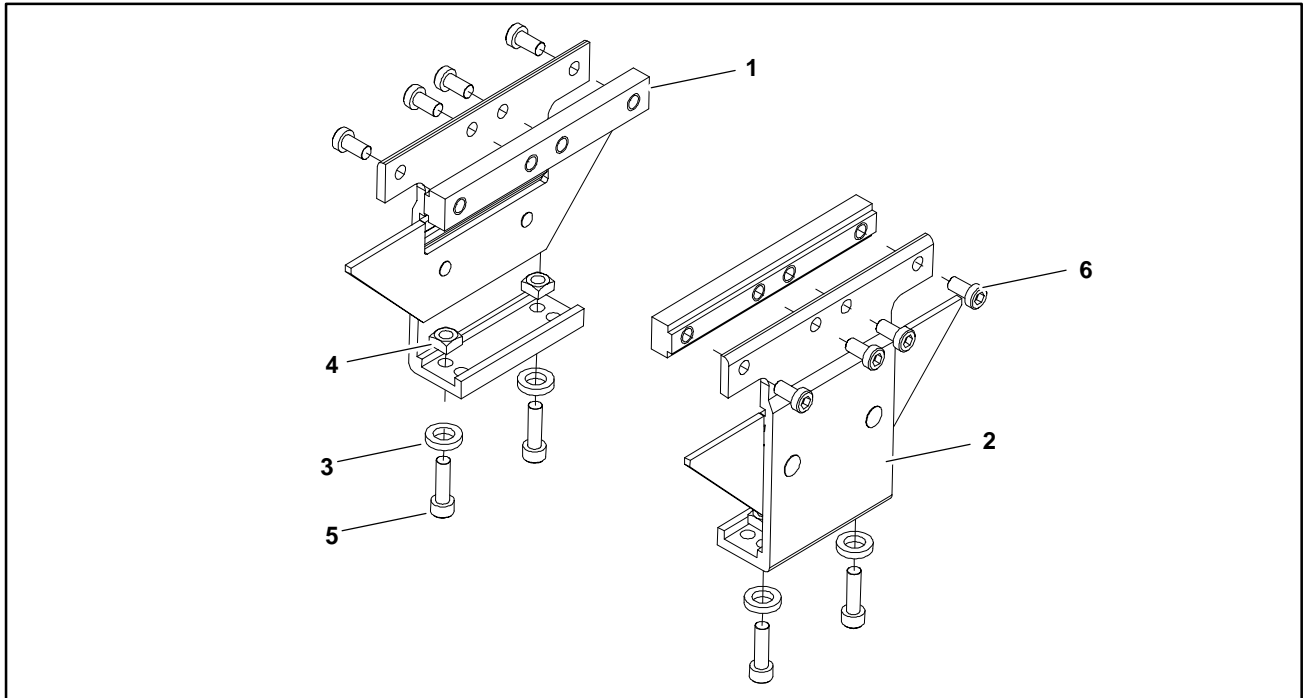

Item	Part Number	Description
1	240331	Frame Connector Bar
2	240846	Cleat Stand Bracket Assembly
3	605279P	Washer

4	807-920	Square Nut M6 5mm x 10mm
5	920620M	Socket Head Screw M6 x 20mm
6	920692M	Socket Head Screw M6 x 12mm

Service Parts

Conveyor Belting

A – Complete Conveyor Belt

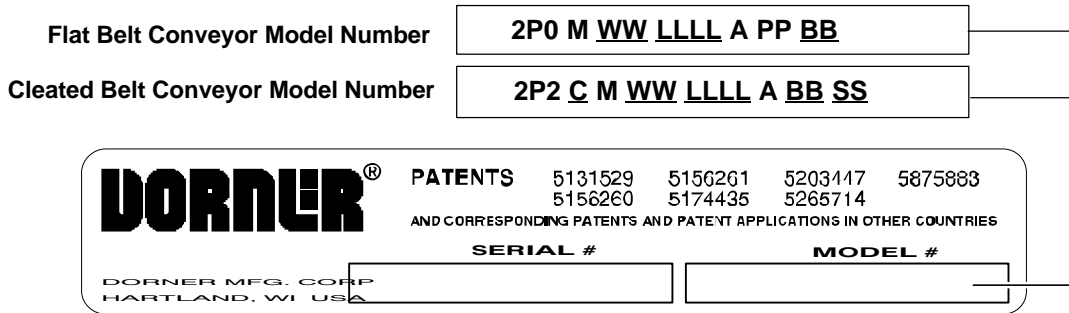
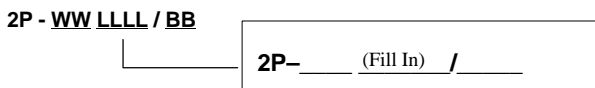

Figure 63

Flat Belt Part Number Configuration

Refer to Dorner patent plate (Figure 63). From the model number, determine conveyor width (“WW”), length (“LLLL”) and belt type (“BB”). Use data to configure belt part number as indicated below.



Cleated Belt Part Number Configuration

Refer to Dorner patent plate (Figure 63). From the model number, determine conveyor width (“WW”), length (“LLLL”), belt type (“BB”) and cleat spacing (“SS”). Use data to configure belt part number as indicated below.

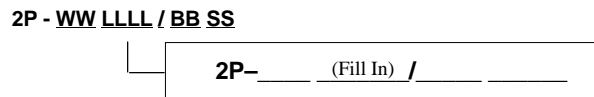

B – Belting Per Foot (305mm)

Flat Belts

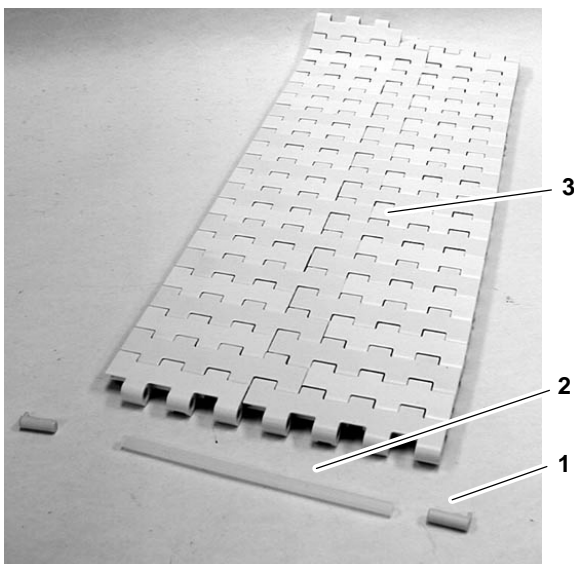

Item	Part Number	Description
1	807-1118	Retaining Pin
2	807-1113	4" Belt Rod
	807-1114	6" Belt Rod
	807-1115	12" Belt Rod
	807-1116	18" Belt Rod
	807-1119	24" Belt Rod
3	2P - WW/BB	Belting per 1ft (305mm) WW=Width: 04,06,12,18,24; BB=Belt Type (See Table Below)

Belt Type BB =	
30	Accumulation, Open Mesh
31	Chemical Resistant, Open Mesh
32	Heat Resistant, Open Mesh
33	ESD, Open Mesh (Class II Charges)
40	Accumulation, Closed Mesh
41	Chemical Resistant, Closed Mesh
42	Heat Resistant, Closed Mesh
43	ESD, Closed Mesh (Class II Charges)

Cleated Belts

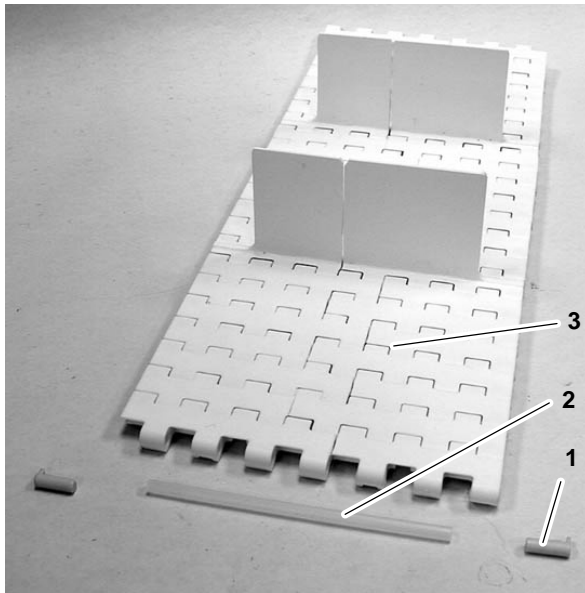

Item	Part Number	Description
1	807-1118	Retaining Pin
2	807-1113	4" Belt Rod
	807-1114	6" Belt Rod
	807-1115	12" Belt Rod
	807-1116	18" Belt Rod
	807-1119	24" Belt Rod
3	2P - WW/BBSS	Belting per 1ft (305mm) WW=Width: 04,06,12,18,24; BB=Belt Type (See Table Below); SS=Cleat Spacing (Links)

Belt Type BB =

34	General Purpose, Open Mesh
35	Chemical Resistant, Open Mesh
36	Heat Resistant, Open Mesh
44	General Purpose, Closed Mesh
45	Chemical Resistant, Closed Mesh
46	Heat Resistant, Closed Mesh

Sidewall Cleated Belts

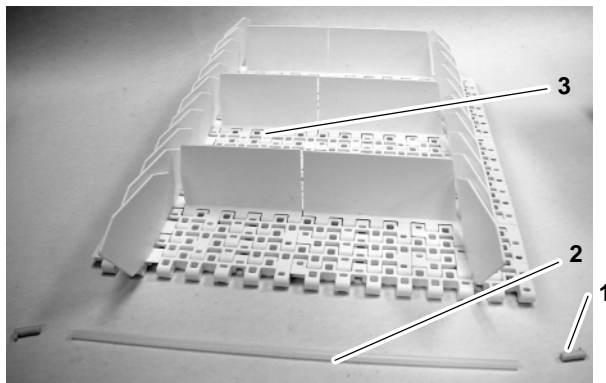

Item	Part Number	Description
1	807-1118	Retaining Pin
2	807-1113	4" Belt Rod
	807-1114	6" Belt Rod
	807-1115	12" Belt Rod
	807-1116	18" Belt Rod
	807-1119	24" Belt Rod
3	2P - WW/BBSS	Belting per 1ft (305mm) WW=Width: 12,18,24; BB=Belt Type (See Table Below) SS=Cleat Spacing (links)

Belt Type BB =

37	General Purpose, Open Mesh
38	Chemical Resistant, Open Mesh
47	General Purpose, Closed Mesh
48	Chemical Resistant, Closed Mesh

Return Policy

No returns will be accepted without prior written factory authorization. When calling for authorization, please have the following information ready for the Dorner Factory representative or your local distributor:

1. Name and address of customer.
2. Item(s) being returned.
3. Reason for return.
4. Customer's original order number used when ordering the item(s).
5. Dorner or distributor invoice number.

A representative will discuss action to be taken on the Returned items and provide a Returned Goods Authorization Number to reference.

There will be a 15% restocking charge on all new items returned for credit where Dorner was not at fault. These will not be accepted after 60 days from original invoice date. The restocking charge covers inspection, cleaning, disassembly, and reissuing to inventory.

If a replacement is needed prior to evaluation of returned item, a purchase order must be issued. Credit (if any) is issued only after return and evaluation is complete.

Dorner has representatives throughout the world. Feel free to contact Dorner for the name of your local representative. Our technical sales and service staff will gladly help with your questions on Dorner products.

For a copy of Dorner's Limited Warranty, contact factory, distributor, service center or visit our website at www.dorner.com.

**For replacement parts, contact an authorized
Dorner Service Center or the factory.**

DORNER[®]

Dorner Mfg. Corp. reserves the right to change or discontinue products without notice. All products and services are covered in accordance with our standard warranty. All rights reserved. ©Dorner Mfg. Corp. 2000

DORNER MFG. CORP.

975 Cottonwood Ave., PO Box 20
Hartland, WI 53029-0020 USA

USA

TEL 1-800-397-8664 (USA)

FAX 1-800-369-2440 (USA)

Outside the USA:

TEL 1-262-367-7600, FAX 1-262-367-5827

DORNER

Arnold-Sommerfeld-Ring 2
D-52499 Baesweiler

Germany

TEL (02401) 80 52 90

FAX (02401) 80 52 93

Internet: www.dorner.com