

3200 & LPZ Series Top Mount Drive Package for Light & Standard Load 60 Hz Gearmotors





Table of Contents

Warnings – General Safety	2	Preventive Maintenance & Adjustment	7
Introduction	2	Required Tools	7
Product Description	3	Timing Belt Tensioning	7
Specifications	3	Timing Belt Replacement	8
Gearmotors	5	Drive or Driven Pulley Replacement	8
3200 Belt Speeds	5	Gear Reducer Replacement	8
Installation	5	Motor Replacement	10
Required Tools	5	Service Parts	12
Mounting	5	Top Mount Drive Package	12
		Gearmotors	13
		Return Policy	14

Warnings – General Safety



	WARNING	
<p>The safety alert symbol, black triangle with white exclamation, is used to alert you to potential personal injury hazards.</p>		



		WARNING
<p>Gearmotors may be HOT. DO NOT TOUCH Gearmotors.</p>		

		DANGER
<p>Climbing, sitting, walking or riding on conveyor will cause severe injury. KEEP OFF CONVEYORS.</p>		

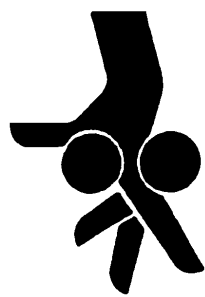
		WARNING
<p>Exposed moving parts can cause severe injury. REPLACE ALL GUARDS BEFORE RUNNING CONVEYOR.</p>		

		DANGER
<p>Do NOT OPERATE CONVEYORS IN AN EXPLOSIVE ENVIRONMENT.</p>		

		WARNING
<p>Dorner cannot control the physical installation and application of conveyors. Taking protective measures is the responsibility of the user.</p> <p>When conveyors are used in conjunction with other equipment or as part of a multiple conveyor system, CHECK FOR POTENTIAL PINCH POINTS and other mechanical hazards before system start-up.</p>		

		WARNING
<p>Exposed moving parts can cause severe injury. LOCK OUT POWER before removing guards or performing maintenance.</p>		

Introduction

IMPORTANT: Some illustrations may show guards removed. Do NOT operate equipment without guards.

Upon receipt of shipment:

- Compare shipment with packing slip. Contact factory regarding discrepancies.
- Inspect packages for shipping damage. Contact carrier regarding damage.
- Accessories may be shipped loose. See accessory instructions for installation.

Dorner 3200 Series conveyors are covered by patent numbers 5156260, 5156261, 5203447, 5265714 and patent applications in other countries.

Dorner LPZ Series conveyors are covered by patent numbers 5156260, 5156261, 5203447, 5265714, 5875883 and patent applications in other countries.

Dorner's Limited Warranty applies.

Dorner reserves the right to make changes at any time without notice or obligation.

Product Description

Refer to Figure 1 for typical components.

Typical Components	
A	Conveyor
B	Mounting Bracket
C	Gearmotor
D	Timing Belt Tensioner
E	Cover
F	Timing Belt
G	Drive Pulley
H	Driven Pulley

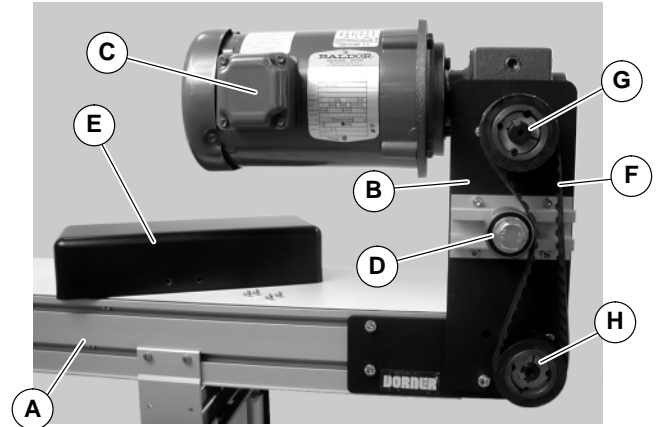

Figure 1

Specifications

Gearmotor Mounting Package Models:

Example:

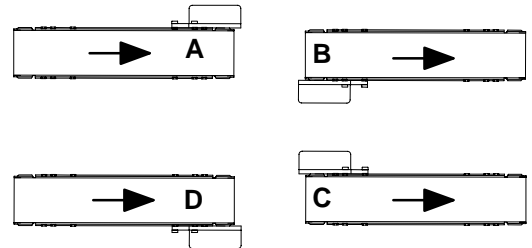
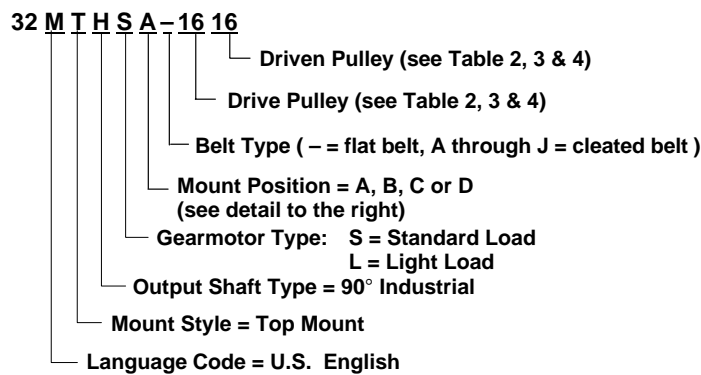

Table 1: Gearmotor Specifications

Item	Light Load Gearmotor			Standard Load Gearmotor			
	Single-Phase	Three Phase	DC Variable Speed	Single-Phase	Three Phase	VFD Variable Speed	DC Variable Speed
Output Power	0.25 hp (0.19 kw)			0.5 hp (0.37 kw)			
Input Voltage	115VAC	208 – 230/460 VAC	130VDC	115VAC	208 – 230/460 VAC	230 VAC	90VDC
Input Frequency	60Hz		N/A	60Hz		10 – 60Hz	N/A
Input Current (Amperes)	5.0	1.2/0.6	2.2	7.4	2.1 – 2/1	1.6	5.0
Gearmotor Ratios	5:1, 10:1, 20:1, 40:1, 60:1			5:1, 10:1, 20:1, 40:1, 60:1			
Frame Size	NEMA 42CZ			NEMA 56C			
Motor Type	Totally enclosed, Fan cooled			Totally enclosed, Fan cooled			

Specifications

Table 2: Belt Speeds for Fixed Speed 90° 60 Hz Gearmotors

Light Load Gearmotors				Standard Load Gearmotors				Belt Speed		Drive Pulley	Driven Pulley
Part Number	RPM	In-lb	N-m	Part Number	RPM	In-lb	N-m	Ft/min	M/min		
32M060HL4(vp)FN	29	226	25.5	32M060HS4(vp)FN	29	226	25.5	23	7.0	16	16
32M040HL4(vp)FN	43	237	26.8	32M040HS4(vp)FN	43	247	27.9	34	10.4	16	16
32M040HL4(vp)FN	43	237	26.8	32M040HS4(vp)FN	43	247	27.9	52	15.8	24	16
32M020HL4(vp)FN	86	142	16	32M020HS4(vp)FN	86	248	27.9	69	21.0	16	16
32M020HL4(vp)FN	86	142	16	32M020HS4(vp)FN	86	248	27.9	103	31.4	24	16
32M010HL4(vp)FN	173	78	8.8	32M010HS4(vp)FN	173	156	17.6	137	41.8	16	16
32M010HL4(vp)FN	173	78	8.8	32M010HS4(vp)FN	173	156	17.6	172	52.4	20	16
32M010HL4(vp)FN	173	78	8.8	32M010HS4(vp)FN	173	156	17.6	206	62.8	24	16
N/A	N/A	N/A	N/A	32M005HS4(vp)FN	345	81	9.1	275	83.8	16	16
N/A	N/A	N/A	N/A	32M005HS4(vp)FN	345	81	9.1	343	104.5	20	16
N/A	N/A	N/A	N/A	32M005HS4(vp)FN	345	81	9.1	412	125.6	24	16

(vp) = voltage and phase
 11 = 115 V, 1-phase
 23 = 208 – 230/460 V, 3-phase

Table 3: Belt Speeds for Variable Speed 90° DC Gearmotors

Light Load Gearmotors				Standard Load Gearmotors				Belt Speed		Drive Pulley	Driven Pulley
Part Number	RPM	In-lb	N-m	Part Number	RPM	In-lb	N-m	Ft/min	M/min		
32M060HLD3DEN	42	198	22.4	32M060HSD9DEN	42	198	22.4	4.0 – 33	1.2 – 10	16	16
32M040HLD3DEN	63	163	18.4	32M040HSD9DEN	63	215	24.3	6.0 – 50	1.8 – 15	16	16
32M040HLD3DEN	63	163	18.4	32M040HSD9DEN	63	215	24.3	9.0 – 75	2.7 – 23	24	16
32M020HLD3DEN	125	98	11.1	32M020HSD9DEN	125	196	22.1	12 – 100	3.6 – 30	16	16
32M020HLD3DEN	125	98	11.1	32M020HSD9DEN	125	196	22.1	18 – 150	5.5 – 45	24	16
32M010HLD3DEN	250	54	6.1	32M010HSD9DEN	250	108	12.2	24 – 200	7.3 – 61	16	16
32M010HLD3DEN	250	54	6.1	32M010HSD9DEN	250	108	12.2	30 – 250	9.1 – 76	20	16
32M010HLD3DEN	250	54	6.1	32M010HSD9DEN	250	108	12.2	36 – 300	11 – 92	24	16

Table 4: Belt Speeds for Fixed Speed 90° VFD Gearmotors



Standard Load Gearmotors				Belt Speed		Drive Pulley	Driven Pulley
Part Number	RPM	In-lb	N-m	Ft/min	M/min		
32M060HS423EN	29	226	25.5	2.3 – 22.9	0.7 – 7.0	16	16
32M040HS423EN	43	247	27.9	3.4 – 34.3	1.0 – 10.5	16	16
32M040HS423EN	43	247	27.9	5.1 – 51.5	1.6 – 15.7	24	16
32M020HS423EN	86	248	27.9	6.9 – 68.6	2.1 – 20.9	16	16
32M020HS423EN	86	248	27.9	10.3 – 103.0	3.1 – 31.4	24	16
32M010HS423EN	173	156	17.6	13.7 – 137.3	4.2 – 41.9	16	16
32M010HS423EN	173	156	17.6	17.2 – 171.6	5.2 – 52.3	20	16
32M010HS423EN	173	156	17.6	20.6 – 205.9	6.3 – 62.8	24	16
32M005HS423EN	345	81	9.1	27.5 – 274.6	8.4 – 83.7	16	16
32M005HS423EN	345	81	9.1	34.3 – 343.2	10.5 – 104.6	20	16
32M005HS423EN	345	81	9.1	41.2 – 411.9	12.6 – 125.6	24	16

NOTE: For belt speed other than those listed, contact factory for details.

Required Tools

- Hex key wrenches:
2 mm, 2.5 mm, 3 mm, 5 mm
- Straight edge
- Torque wrench

Mounting

		<h3>WARNING</h3>
	<p>Exposed moving parts can cause severe injury. LOCK OUT POWER before removing guards or performing maintenance.</p>	

Installation Component List	
I	Top Mount Assembly
J	Drive Pulley
K	Cover
L	M4 Socket Head Screws (4x)
M	Driven Pulley
N	Key
O	M6 Socket Head Screws (4x)
P	M8 Socket Head Screws (2x)
Q	Timing Belt

1. Typical components (Figure 2)

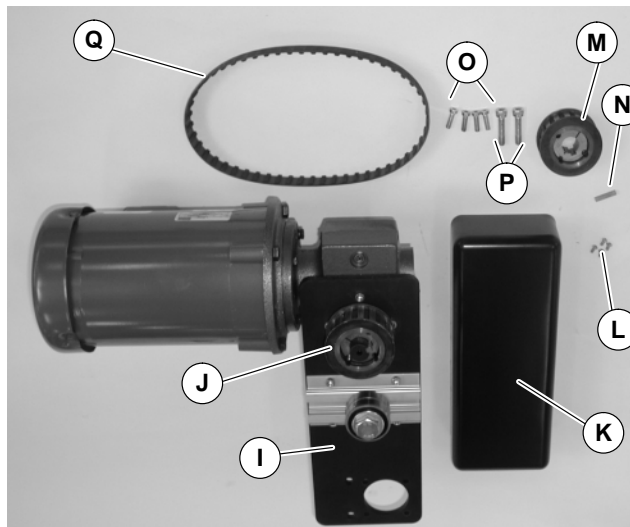

Figure 2

NOTE: Gearmotor may be operated in positions 1, 2 or 3 (Figure 3).

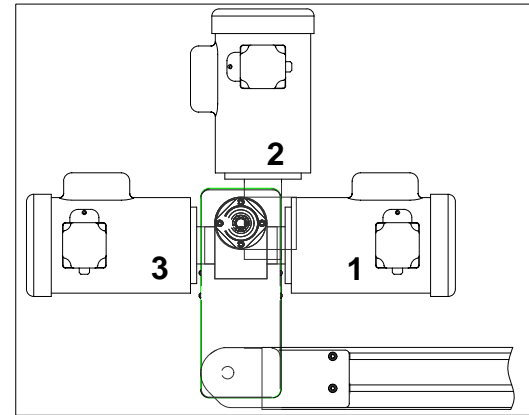

Figure 3

2. If required, change gearmotor position by removing four (4) screws (R of Figure 4). Rotate gearmotor to other position and replace screws (R). Tighten to 110 in-lb (12 Nm).

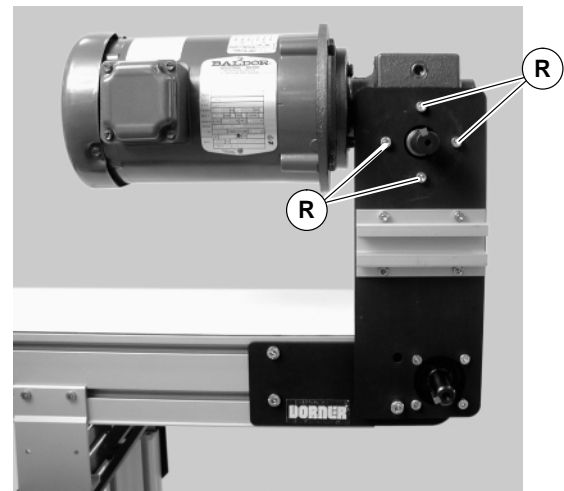

Figure 4

3. Locate drive output shaft (U of Figure 5). Remove two (2) M8 screws (T) and four (4) M6 screws (S) and discard.

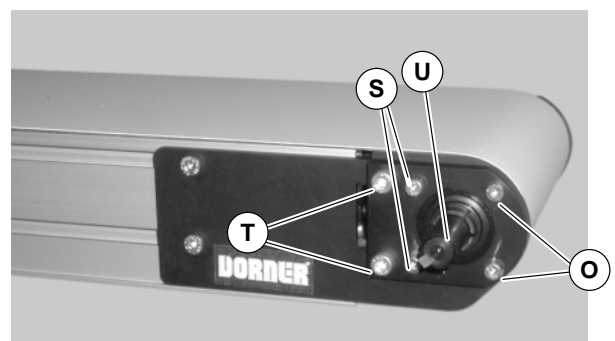

Figure 5

Installation

- Attach mount assembly (I of Figure 6) with two (2) M8 screws (P) and four (4) M6 screws (O). Tighten M6 screws (O) to 146 in-lbs (16.5 N-m) and M8 screws (P) to 288 in-lbs (32.5 N-m).

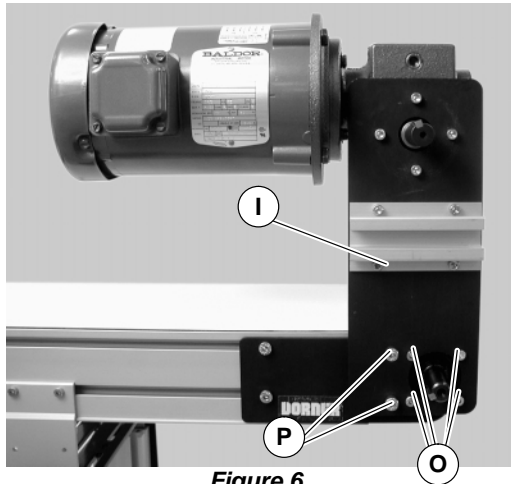

Figure 6

- Using a straight edge (V of Figure 8), align driven pulley (M) with drive pulley (J). Tighten driven pulley taper-lock screws (W of Figure 9).

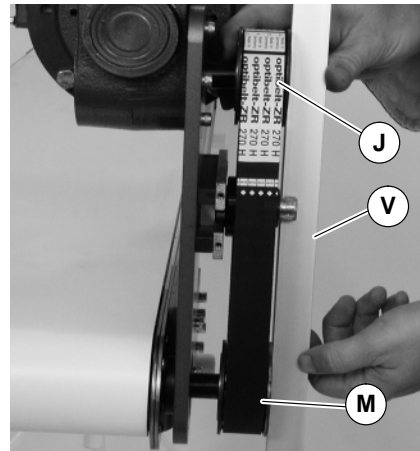

Figure 8

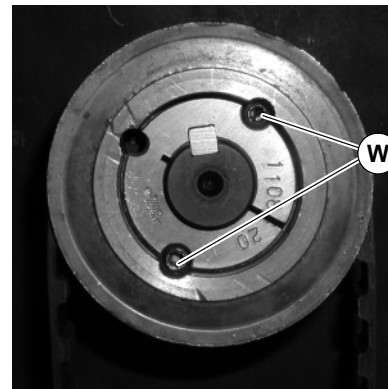

Figure 9

- Install key (N of Figure 7).

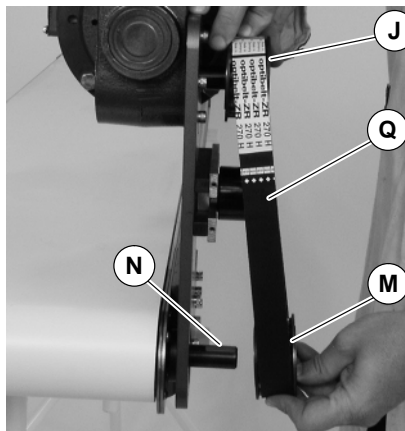

Figure 7

- Wrap timing belt (Q) around driven pulley (M) and drive pulley (J). Install driven pulley (M) onto conveyor shaft.

- Depending on conveyor belt travel (direction 1 or 2), locate timing belt tensioner (X of Figure 10) as shown. Tension timing belt to obtain 1/8" (3 mm) deflection for 6 lb (3 Kg) of force at timing belt mid-point (Y). Tighten tensioner screw to 110 in-lb (12 Nm).

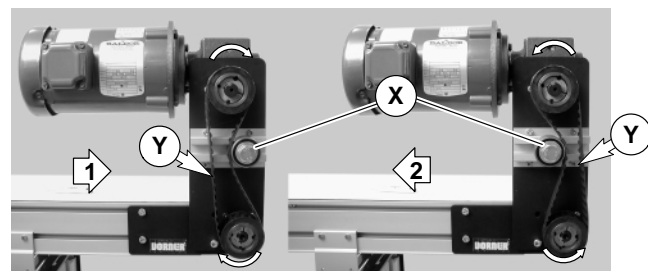
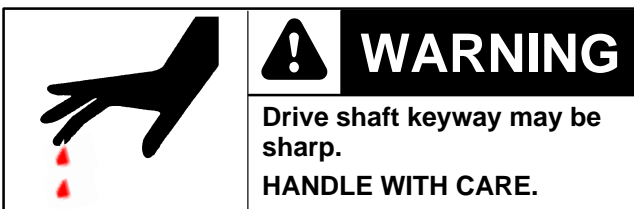

Figure 10



9. Install cover (K of Figure 11) with four (4) screws (L). Tighten screws to 35 in-lb (4 Nm).

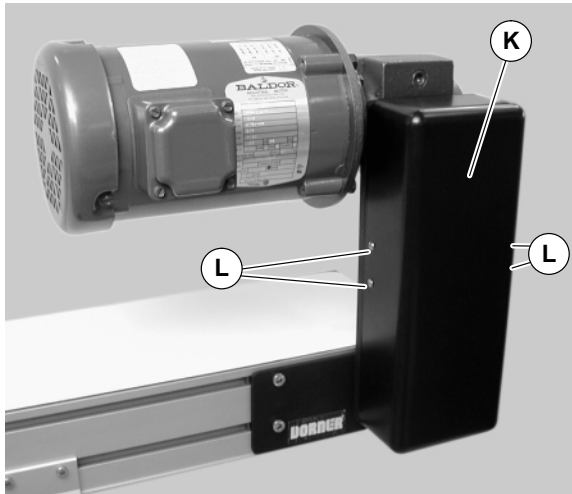



Figure 11

Preventive Maintenance and Adjustment

Required Tools

- Hex key wrenches:
 - 2 mm, 2.5 mm, 3 mm, 5 mm
- Adjustable wrench (for hexagon head screws)
- Straight edge
- Torque wrench

Timing Belt Tensioning

	 WARNING Exposed moving parts can cause severe injury. LOCK OUT POWER before removing guards or performing maintenance.
---	--

1. Remove four (4) screws (L of Figure 11) and remove cover (K).
2. Loosen tensioner (X of Figure 12).

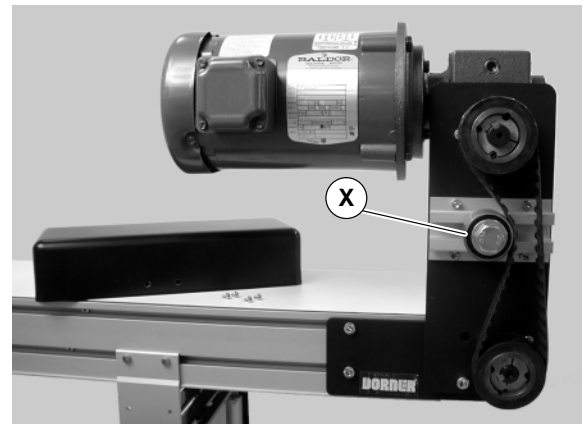

Figure 12

3. Depending on conveyor belt travel (direction 1 or 2), locate timing belt tensioner (X of Figure 10) as shown. Tension timing belt to obtain 1/8" (3 mm) deflection for 6 lb (3 Kg) of force at timing belt mid-point (Y). Tighten tensioner screw to 110 in-lb (12 Nm).
4. Install cover (K of Figure 11) with four (4) screws (L). Tighten screws to 35 in-lb (4 Nm).

Preventive Maintenance and Adjustment

Timing Belt Replacement



1. Remove four (4) screws (L of Figure 11) and remove cover (K).
2. Loosen tensioner (X of Figure 12).
3. Remove timing belt (Q of Figure 13).

NOTE: If timing belt does not slide over pulley flange, loosen driven pulley taper-lock screws (W of Figure 13) and remove pulley with belt (Q). For re-installation, see steps 6 and 7 on beginning on page 6.

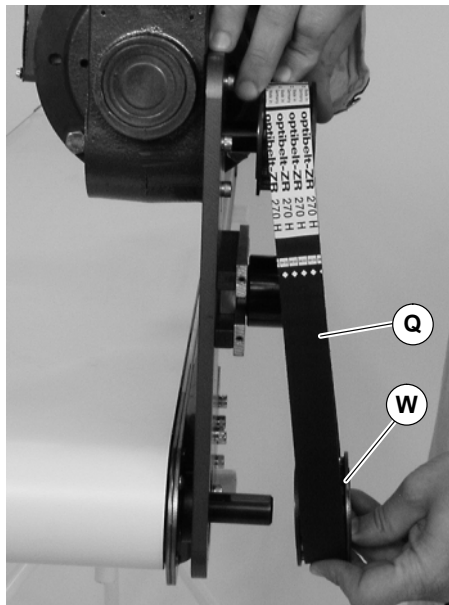

Figure 13

4. Install new timing belt.
5. Depending on conveyor belt travel (direction 1 or 2), locate timing belt tensioner (X of Figure 10) as shown. Tension timing belt to obtain 1/8" (3 mm) deflection for 6 lb (3 Kg) of force at timing belt mid-point (Y). Tighten tensioner screw to 110 in-lb (12 Nm).
6. Install cover (K of Figure 11) with four (4) screws (L). Tighten screws to 35 in-lb (4 Nm).

Drive or Driven Pulley Replacement



1. Complete steps 1 through 3 of "Timing Belt Replacement" section on page 7.
2. Remove taper-lock screws (W of Figure 14). Insert one (1) of taper lock screws (W of Figure 14) in remaining hole (Z). Tighten screw (W) until pulley is loose. Remove pulley and taper hub assembly.

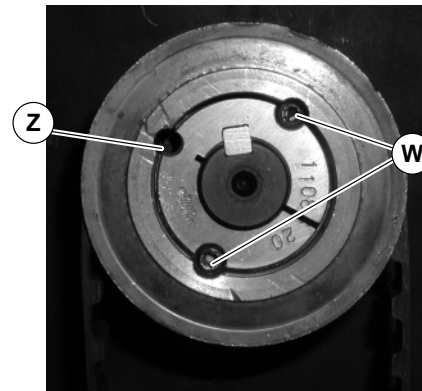
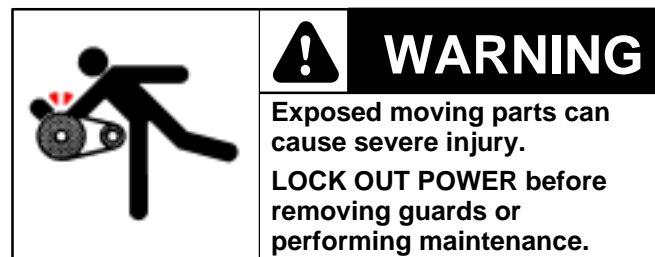

Figure 14

NOTE: If drive pulley (J of Figure 17) is replaced, wrap timing belt around drive pulley and complete step 3.

3. Complete steps 6 through 9 of "Installation" section beginning on page 6.

Gear Reducer Replacement



1. Remove four (4) screws (L of Figure 11) and remove cover (K).
2. Loosen M10 shaft locking screw (AA of Figure 15).

Preventive Maintenance and Adjustment

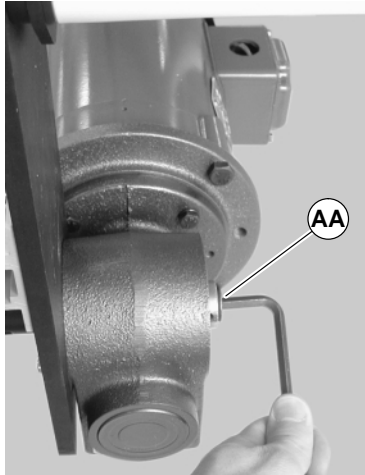

Figure 15

3. Loosen tensioner (X of Figure 12).
4. Loosen taper-lock screws (W of Figure 16) and remove drive pulley: Insert one (1) of taper lock screws (W) in remaining hole (Z). Tighten screw (W) until pulley is loose. Remove pulley (J of Figure 17), taper hub assembly (AB), and timing belt (Q)

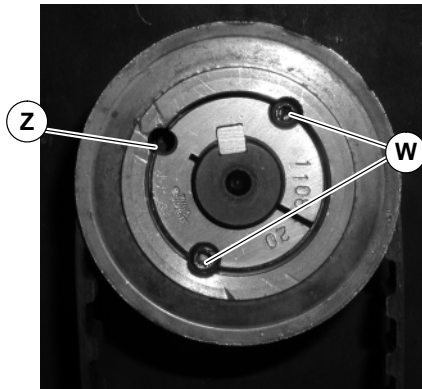

Figure 16

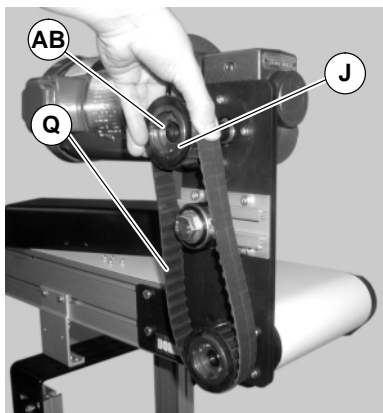

Figure 17

5. Remove four (4) gear reducer mounting screws (R of Figure 18). Remove gearmotor.

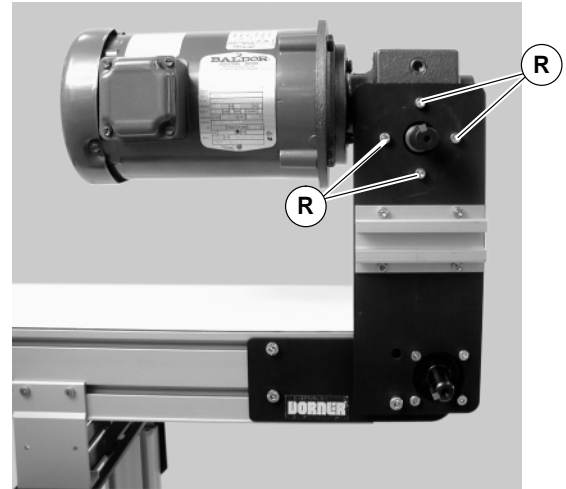

Figure 18

6. Remove four screws (AC of Figure 19). Detach motor (AD) from gear reducer (AE). Retain motor output shaft key (AF).

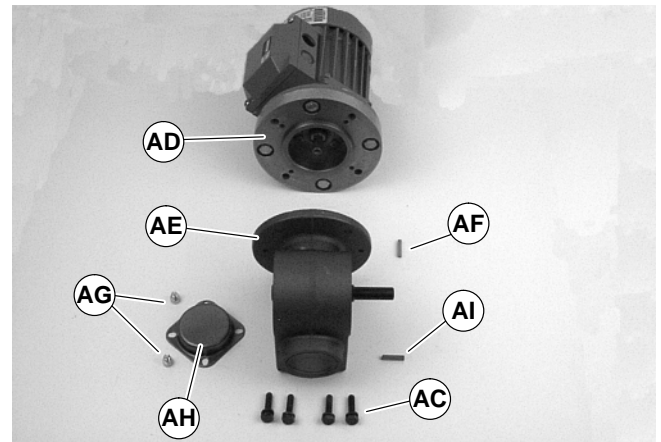

Figure 19

7. Remove two (2) screws (AG) and detach output shaft cover (AH).
8. Remove M10 shaft locking screw (AA of Figure 20), remove gear reducer output shaft (AJ) and key (AI).

NOTE: Output shaft (AJ of Figure 20) is held in Gear Reducer with a tapered press fit. Removal may require use of an arbor press.

Preventive Maintenance and Adjustment

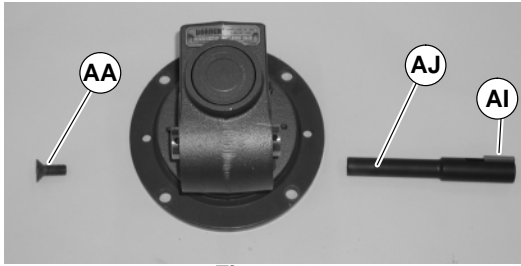

Figure 20

9. Insert the new shaft with key (AI of Figure 20) into new gear reducer. Tighten M10 shaft locking screw (AK) to 300 in-lbs (34 N-m).

IMPORTANT: Be extremely careful when coupling motor to gear reducer. Avoid misalignment and forcing the connection causing possible permanent gear reducer seal damage.

10. With key (AF of Figure 19) in keyway, slide motor (AD) and gear reducer (AE) together. Install screws (AC) and tighten.
11. Install gearmotor to mounting bracket and tighten screws (R of Figure 18) to 110 in-lb (12 Nm).

NOTE: Drive pulley (J of Figure 17) is removed. Wrap timing belt around drive pulley and complete step 12.

12. Complete steps 6 through 9 of “Installation” section beginning on page 6.

Motor Replacement

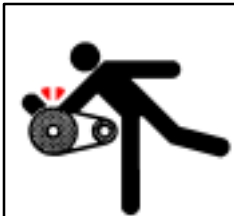

WARNING

Exposed moving parts can cause severe injury. LOCK OUT POWER before removing guards or performing maintenance.



DANGER

Hazardous voltage will cause severe injury or death.

LOCK OUT POWER BEFORE WIRING.

1. For single phase motor, unplug power cord from outlet.
2. For three phase and VFD variable speed motor:
 - a. Loosen terminal box screws (AL of Figure 21) and remove cover (AM).

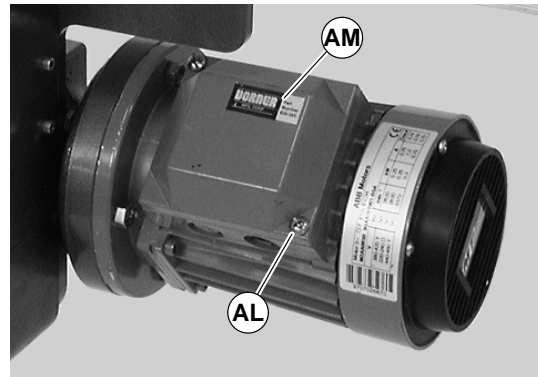

Figure 21

- b. Record wire colors on terminals 1, 2 and 3. Loosen wire nuts and remove wires 1, 2 and 3.
 - c. Loosen cord grip and remove cord.
3. For DC variable speed motor, unplug motor cord at disconnect (AN of Figure 22).

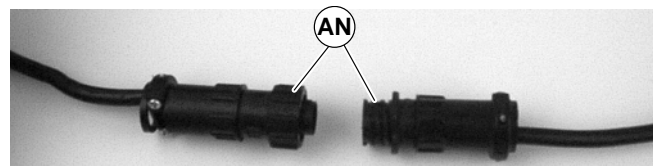

Figure 22

Preventive Maintenance and Adjustment

4. Remove four (4) screws (AC of Figure 23). Detach motor (AD) from gear reducer (AE). Retain motor output shaft key (AF).

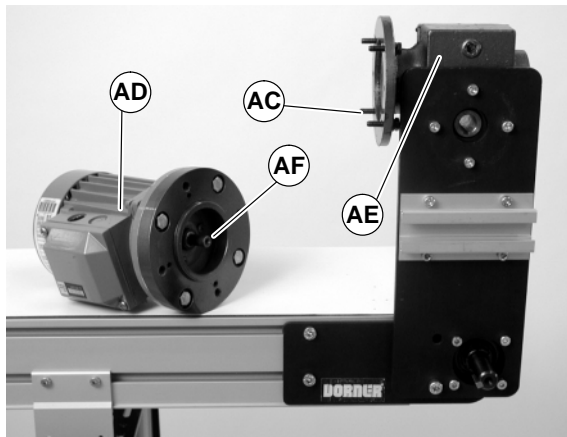

Figure 23

5. With key (AF of Figure 24) in keyway, slide motor (AD) and gear reducer together. Install screws (AC) and tighten.

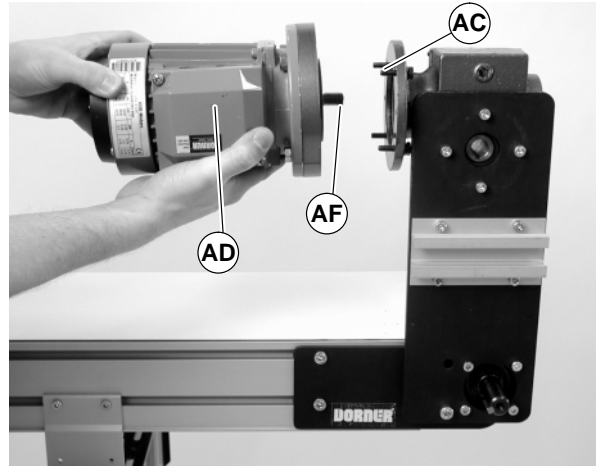

Figure 24

IMPORTANT: Be extremely careful when coupling motor to gear reducer. Avoid misalignment and forcing the connection causing possible permanent gear reducer seal damage.

6. Replace wiring:

- For a single phase motor, reverse step 1 on this page.
- For a three phase or VFD variable speed motor, reverse step 2 on this page.
- For a DC variable speed motor, reverse step 3 on this page.

Service Parts

NOTE: For replacement parts other than those shown in this section, contact an authorized Dorner Service Center or Dorner Manufacturing.

3200 Series Conveyors Top Mount Drive Package for Standard Load 90° Industrial Gearmotors

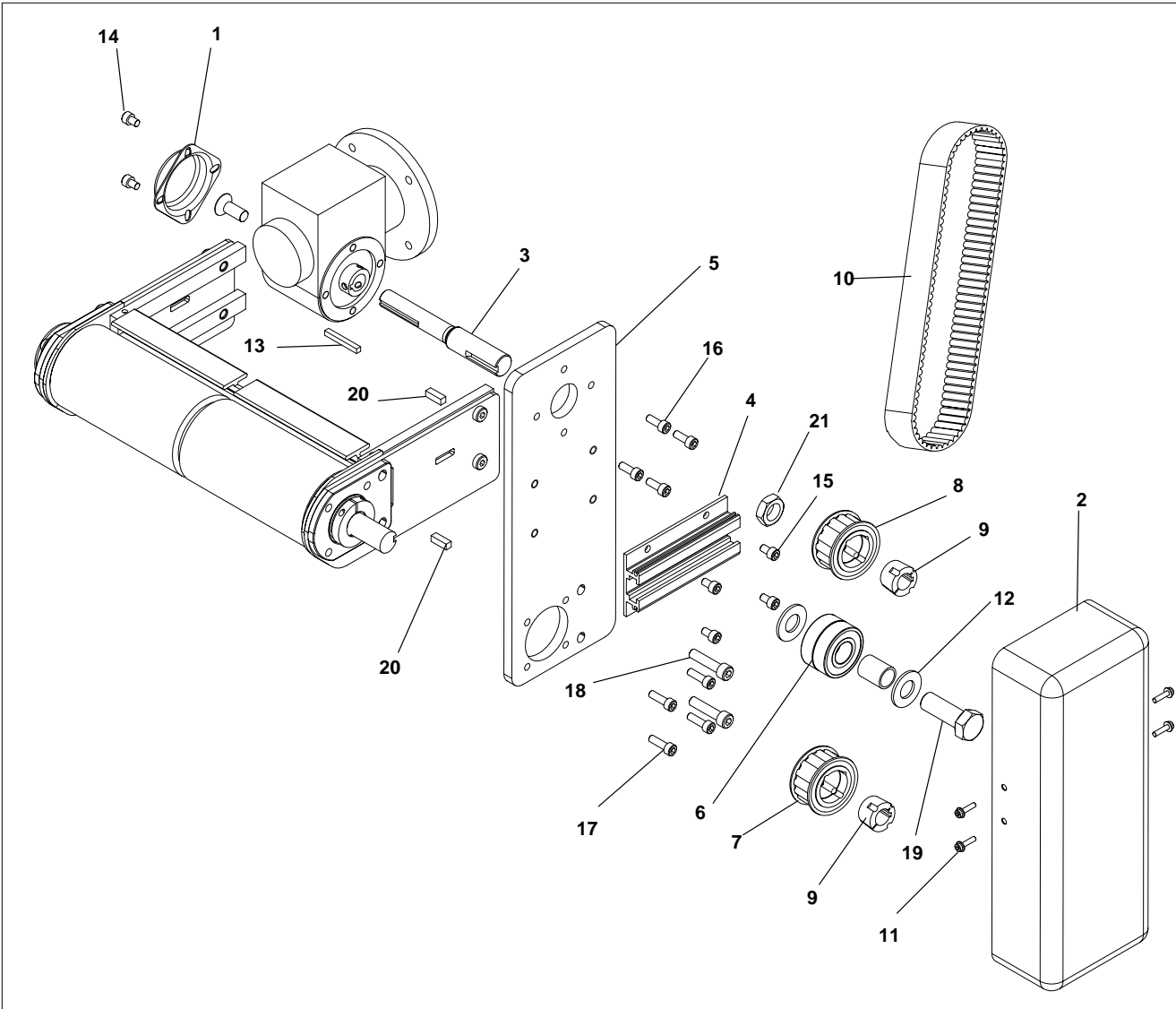

Item	Part Number	Description
1	300139	Bearing Shaft Cover
2	300871	Drive Cover
3	301146	Grove Gearhead Output Shaft
4	301076	Drive Tensioner Slide
5	301151	Mounting Plate
6	301153	Tensioner Bearing Assy
7	811-123	Driven Pulley, 14 Tooth, Taper Lock TL1108

	811-126	Driven Pulley, 16 Tooth, Taper Lock TL1108
8	811-126	Drive Pulley, 16 Tooth, Taper Lock TL1108
	811-127	Drive Pulley, 18 Tooth, Taper Lock TL1210
	811-135	Drive Pulley, 20 Tooth, Taper Lock TL1210
	811-136	Drive Pulley, 22 Tooth, Taper Lock TL1610

	811-137	Drive Pulley, 24 Tooth, Taper Lock TL1610
9	811-288	Taper Lock Bushing, 20MM, TL1108
	811-289	Taper Lock Bushing, 20MM, TL1210
	811-290	Taper Lock Bushing, 20MM, TL1610
10	814-059	Timing Belt, 1.0" W x 27.0" L
	814-060	Timing Belt, 1.0" W x 28.0" L
11	910412M	Button Head Screw M4 x 12mm
12	911-013	Flat Washer

13	912-084	Square Key
14	920608M	Socket Head Screw M6 x 8mm
15	920610M	Socket Head Screw M6 x 10mm
16	920616M	Socket Head Screw M6 x 16mm
17	920620M	Socket Head Screw M6 x 20mm
18	920835M	Socket Head Screw M8 x 35mm
19	961645M	Socket Head Screw M16 x 45mm
20	980636M	Square Key
21	991610M	Hex Jam Nut M16

3200 Standard Load 90° Industrial Gearmotors

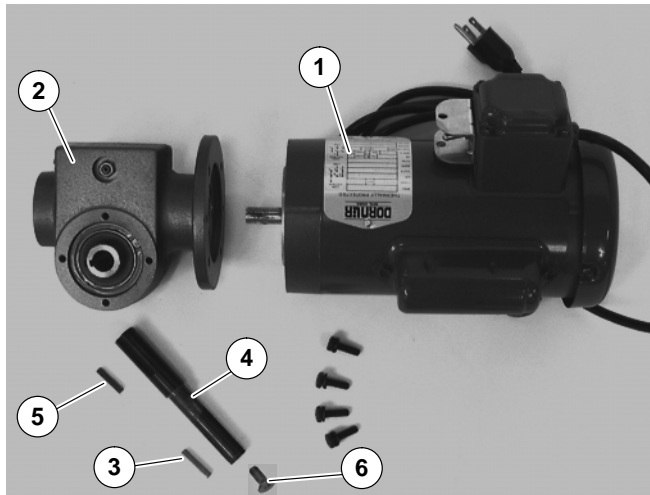

Figure 25

Item	Part No.	Part Description
1	826-328	Motor, 0.25hp (0.19Kw), 115/230 Volts, 60 Hz, 1-Phase
	826-337	Motor, 0.25hp (0.19Kw), 115/230 Volts, 60 Hz, 1-Phase with Reversing
	826-330	Motor, 0.25hp (0.19Kw), 208-230/460 Volts, 60 Hz, 3-Phase
	826-332	Motor, 0.25hp (0.19Kw), 130 VDC
	826-017	Motor, 0.5hp (0.37Kw), 115/230 Volts, 60Hz, 1-Phase
	826-025	Motor, 0.5hp (0.37Kw) 208-230/460 Volts, 60Hz, 3 Phase
	826-333	Motor, 0.5hp (0.37Kw), 90VDC
	826-249	Motor, 0.5hp (0.37Kw), 230 Volts, 3 Phase Inverter Duty
	2	32M005HL
32M010HL		Gear Reducer, 10:1, NEMA 42CZ
32M020HL		Gear Reducer, 20:1, NEMA 42CZ
32M040HL		Gear Reducer, 40:1, NEMA 42CZ
32M060HL		Gear Reducer, 60:1, NEMA 42CZ
32M005HS		Gear Reducer, 5:1, NEMA 56C
32M010HS		Gear Reducer, 10:1, NEMA 56C
32M020HS		Gear Reducer, 20:1, NEMA 56C
32M040HS		Gear Reducer, 40:1, NEMA 56C
32M060HS	Gear Reducer, 60:1, NEMA 56C	
3	980636M	Pulley Key, 6 mm x 18 mm (2x)
4	301146	Gear Reducer Shaft
5	912-084	Gear Reducer Key, Square, 0.188" x 1.5" L
6	931025M	Flat Head Screw M10 x 25mm

Return Policy

No returns will be accepted without prior written factory authorization. When calling for authorization, please have the following information ready for the Dorner Factory representative or your local distributor:

1. Name and address of customer.
2. Item(s) being returned.
3. Reason for return.
4. Customer's original order number used when ordering the item(s).
5. Dorner or distributor invoice number.

A representative will discuss action to be taken on the Returned items and provide a Returned Goods Authorization Number to reference.

There will be a 15% restocking charge on all new items returned for credit where Dorner was not at fault. These will not be accepted after 60 days from original invoice date. The restocking charge covers inspection, cleaning, disassembly, and reissuing to inventory.

If a replacement is needed prior to evaluation of returned item, a purchase order must be issued. Credit (if any) is issued only after return and evaluation is complete.

Dorner has representatives throughout the world. Feel free to contact Dorner for the name of your local representative. Our technical sales and service staff will gladly help with your questions on Dorner products.

For a copy of Dorner's Limited Warranty, contact factory, distributor, service center or visit our website at www.dorner.com.

DORNER[®]

Dorner Mfg. Corp. reserves the right to change or discontinue products without notice. All products and services are covered in accordance with our standard warranty. All rights reserved. © Dorner Mfg. Corp. 2000

DORNER MFG. CORP.

975 Cottonwood Ave. PO Box 20
Hartland, WI 53029-0020 USA

USA
TEL 1-800-397-8664 (USA)
FAX 1-800-369-2440 (USA)

Outside the USA:
TEL 1-262-367-7600, FAX 1-262-367-5827

DORNER

Arnold-Sommerfeld-Ring 2
D-52499 Baesweiler

Germany
TEL (02401) 80 52 90
FAX (02401) 80 52 93

Internet: www.dorner.com