

6200 Series Industrial End Drive Conveyors



Table of Contents

Warnings – General Safety	2	Belt Installation for Conveyor With Stands and/or Gearmotor Mounting Package	12
Introduction	2	Belt Installation for Conveyor With Optional Gang Drive Pulley	12
Product Description	3	Conveyor Belt Tensioning	12
Specifications	3	Pulley Removal	13
Installation	4	A – Removal of Drive Pulley with Standard 0.47" (12 mm) Diameter Outboard Shaft	13
Required Tools	4	B – Idler Pulley Removal	14
Recommended Installation Sequence	4	C – Gang Drive Pulley Removal	15
Conveyors Up to 13 ft (3962 mm)	4	Bearing Replacement for Drive Pulley with Standard 0.47" (12 mm) Diameter Output Shaft or Idler Pulley ..	15
Conveyors Longer Than 13 ft (3962 mm)	5	Bearing Removal	15
Mounting Brackets	5	Bearing Installation	16
Return Rollers	5	Bearing Replacement for a Gang Drive Pulley	17
2" to 6" (51 mm to 152 mm) Wide Conveyors	6	Bearing Removal	17
8" (203 mm) to 18" (457 mm) Wide Flat Belt Conveyors	7	Bearing Installation	18
Preventative Maintenance & Adjustment	8	Pulley Installation	18
Required Tools	8	Service Parts	20
Standard Tools	8	Drive End Components	20
Special Tools	8	Tension End Components	21
Checklist	8	Conveyor Frame and Extensions	22
Lubrication	8	Gang Drive Thru-Shaft Option	23
Conveyors with Standard 0.47" (12 mm) Diameter Output Shaft	8	–02 0.5" (13 mm) Bolt-On High Side Guides	24
Conveyor with Optional Gang Drive Pulley	8	–03 Bolt-On Side Wipers	25
Return Rollers	9	–04 3" (76 mm) Bolt-On High Side Guides	26
Maintaining Conveyor Belt	9	–05 1.5" (38 mm) Bolt-On High Side Guides	27
Troubleshooting	9	–13 Fully Adjustable UHMW Guides	28
Cleaning	9	–20 Adjustable Width UHMW Guides	29
Conveyor Belt Replacement	9	1" (25 mm) Cleated Belt Conveyor Guides	30
Conveyor Belt Replacement Sequence	9	2" (51 mm) Cleated Belt Conveyor Guides	31
Belt Removal for Conveyor Without Gearmotor Mounting Package or Stands	9	2" (51 mm) Through 6" (152 mm) Flat Belt and Cleated Belt Return Roller	32
Belt Removal for Conveyor With Stands and/or Gearmotor Mounting Package	10	8" (203 mm) Through 18" (457 mm) Flat Belt Return Roller	32
Belt Removal for Conveyor With Optional Gang Drive Pulley	11	Conveyor Mounting Brackets	33
Belt Installation for Conveyor Without Gearmotor Mounting Package or Stands	11	Configuring Conveyor Belt Part Number	33
		Return Policy	34

Warnings – General Safety

	WARNING	
<p>The safety alert symbol, black triangle with white exclamation, is used to alert you to potential personal injury hazards.</p>		

	WARNING
<p>Gearmotors may be HOT. DO NOT TOUCH Gearmotors.</p>	

	DANGER
<p>Climbing, sitting, walking or riding on conveyor will cause severe injury. KEEP OFF CONVEYORS.</p>	

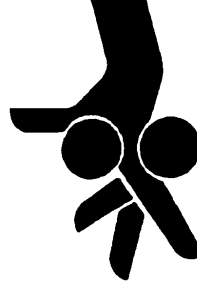
	WARNING
<p>Dorner cannot control the physical installation and application of conveyors. Taking protective measures is the responsibility of the user.</p> <p>When conveyors are used in conjunction with other equipment or as part of a multiple conveyor system, CHECK FOR POTENTIAL PINCH POINTS and other mechanical hazards before system start-up.</p>	

	DANGER
<p>DO NOT OPERATE CONVEYORS IN AN EXPLOSIVE ENVIRONMENT.</p>	

	WARNING
<p>Loosening stand height or angle adjustment screws may cause conveyor sections to drop down, causing severe injury.</p> <p>SUPPORT CONVEYOR SECTIONS PRIOR TO LOOSENING STAND HEIGHT OR ANGLE ADJUSTMENT SCREWS.</p>	

	WARNING
<p>Exposed moving parts can cause severe injury. LOCK OUT POWER before removing guards or performing maintenance.</p>	

Introduction

IMPORTANT: Some illustrations may show guards removed. Do NOT operate equipment without guards.

Upon receipt of shipment:

- Compare shipment with packing slip. Contact factory regarding discrepancies.
- Inspect packages for shipping damage. Contact carrier regarding damage.
- Accessories may be shipped loose. See accessory instructions for installation.

Dorner's Limited Warranty applies.

Dorner 6200 Series conveyors are covered by Patent Nos. 5174435, 6109427 and corresponding patents and patent applications in other countries.

Dorner reserves the right to make changes at any time without notice or obligation.

Dorner has convenient, pre-configured kits of Key Service Parts for all conveyor products. These time saving kits are easy to order, designed for fast installation, and guarantee you will have what you need when you need it. Key Parts and Kits are marked in the Service Parts section of this manual with the Performance Parts Kits logo .

Product Description

Refer to Figure 1 for typical conveyor components.

Typical Components	
A	Conveyor
B	Gearmotor
C	Belt (Cleated Belt Shown)
D	Mounting Plates
E	Stand Mounting Brackets
F	Support Stands
G	Variable Speed Controller
H	Drive End
I	Idler/Tension End

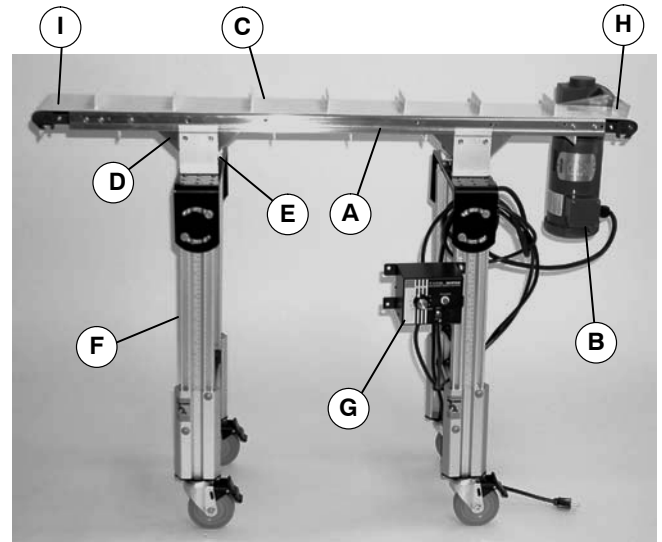
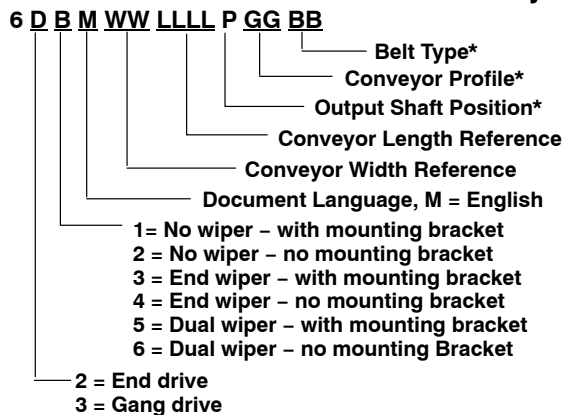

Figure 1

Specifications

Models:

Flat Belt 6200 Series Industrial Conveyor



Cleated Belt 6200 Series Industrial Conveyor

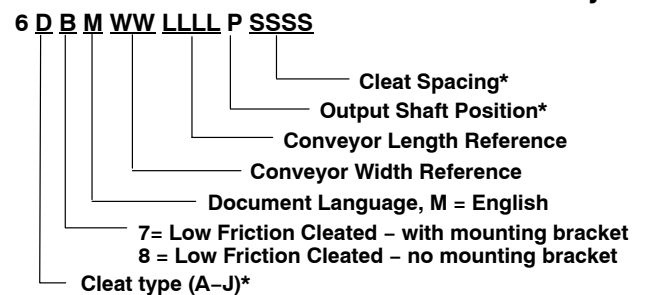

* See "Ordering and Specifications" Catalog for details.

Conveyor Supports:

Maximum Distances:

J = 18" (457 mm)**

K = 6 ft (1829 mm)***

L = 18" (457 mm)

** For Heavy Load Bottom Mount Package, mount support under gear head.

*** For conveyors longer than 13 ft (3962 mm), install support at joint.

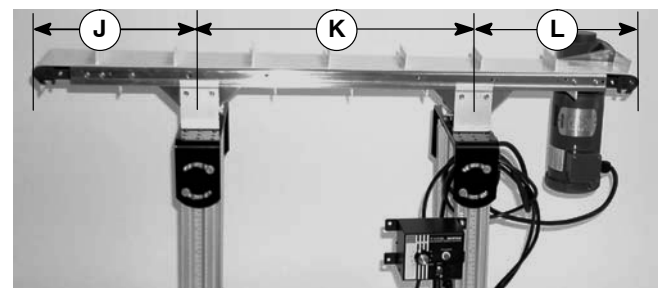

Figure 2

Specifications

Specifications:

NOTE: Maximum conveyor loads based on:

- Non-accumulating product
- Product moving towards gearmotor
- Conveyor being mounted horizontal

Conveyor Width Reference (WW)	02	03	04	05	06	08	10	12	18
Conveyor Belt Width	1.75" (44 mm)	2.75" (70 mm)	3.75" (95 mm)	5" (127 mm)	6" (152 mm)	8" (203 mm)	10" (254 mm)	12" (305 mm)	18" (457 mm)
Maximum Conveyor Load* (See NOTE Below)	30 lb (14 kg)	35 lb (16 kg)	42 lb (19 kg)	50 lb (23 kg)	60 lb (27 kg)	70 lb (32 kg)	80 lb (36 kg)	80 lb (36 kg)	80 lb (36 kg)
Conveyor Start-up Torque*	4 in-lb (0.5 Nm)	5 in-lb (0.6 Nm)	6 in-lb (0.7 Nm)	7 in-lb (0.8 Nm)	8 in-lb (0.9 Nm)	10 in-lb (1.1 Nm)	12 in-lb (1.4 Nm)	14 in-lb (1.5 Nm)	15 in-lb (1.7 Nm)
Belt Travel	3.5" (88 mm) per revolution of pulley								
Maximum Belt Speed*	235 feet/minute (72 meters/minute)								
Belt Take-up	0.38" (10 mm) of stroke = 0.75" (19 mm) of belt take-up								

Conveyor Length Reference (LL)	02	03	04	05	06	07	08	09	10	11	12	13**	14**	15**	16**	17**	18**
Conveyor Length	2-ft (610 mm)	3-ft (914 mm)	4-ft (1219 mm)	5-ft (1524 mm)	6-ft (1829 mm)	7-ft (2134 mm)	8-ft (2438 mm)	9-ft (2743 mm)	10-ft (3048 mm)	11-ft (3353 mm)	12-ft (3658 mm)	13-ft (3962 mm)**	14-ft (4267 mm)**	15-ft (4572 mm)**	16-ft (4877 mm)**	17-ft (5182 mm)**	18-ft (5486 mm)**

* See "Ordering and Specifications" Catalog for details.

** Lengths available only in 6" (152 mm) & wider conveyors.

Installation

NOTE: Conveyor **MUST** be mounted straight, flat and level within confines of conveyor. Use a level (M of Figure 3) for setup.



Figure 3

Required Tools

- Hex key wrenches: 4 mm, 5 mm
- 10 mm open-end wrench

- Level
- Torque wrench

Recommended Installation Sequence

- Assemble conveyor (if required)
- Attach mounting brackets to conveyor (see page 5)
- Install stands (see accessory instructions)
- Attach conveyor to stands
- Mount gearmotor mounting package (see accessory instructions)
- Attach guides/accessories (see "Service Parts" section, pages 20 through 33)

Conveyors Up to 13 ft (3962 mm)

No assembly is required. Install mounting brackets and return rollers. Refer to "Mounting Brackets" on page 5 and "Return Rollers" on page 6.

Conveyors Longer Than 13 ft (3962 mm)

Illustration References

N	Conveyor frame without belt
O	M6 x 10 mm Low-Head Screws (6x) (shipped loose)
P	Connector Strips (2x) (Attached to conveyor section)
Q	Conveyor frame with belt

1. Typical components (Figure 4)

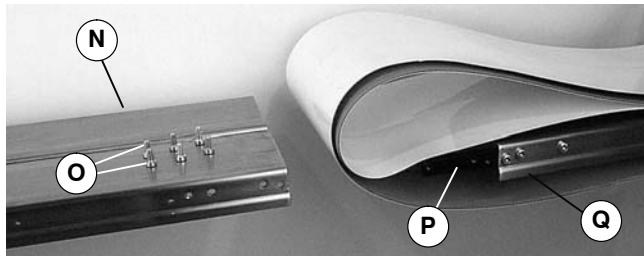

Figure 4

2. Compress tension end (Figure 5). Refer to steps 3 and 4 under the “Belt Removal for Conveyor Without Gearmotor Mounting Package or Stands” on page 9.

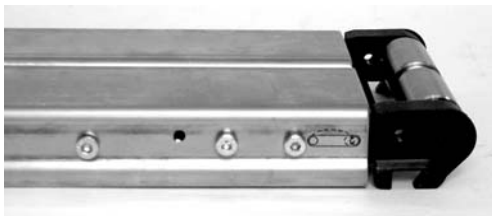

Figure 5

3. Roll out conveyor belt.

4. Place conveyor frame (N Figure 6) into belt loop.

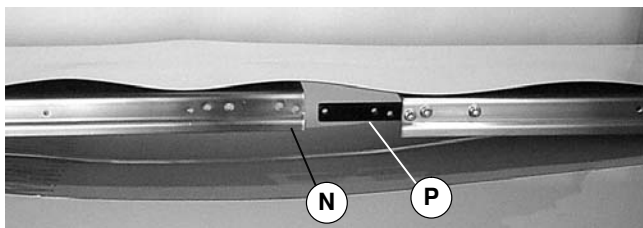

Figure 6

5. Join conveyor sections (N and Q of Figure 7). Install screws (O) through frame and into connector bar (P) on both sides. Tighten screws to 60 in-lb (7 Nm).

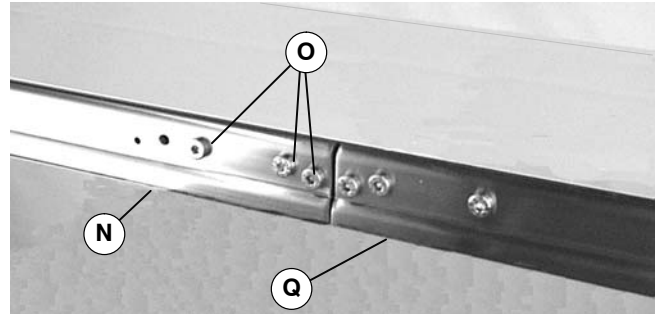

Figure 7

6. Tension conveyor belt. Refer to “Conveyor Belt Tensioning” on page 12.

Mounting Brackets

1. Typical mounting bracket components (Figure 8)

Mounting Bracket Components (One Pair)

R	M6 x 12 mm Socket Head Screws (4x)
S	M6 x 20 mm Socket Head Screw (4x)
T	Hard Washer (4x)
U	M6 Square Nut (4x)
V	Stand Mounting Bracket (2x)
W	Mounting Plate, Flat Belt (2x)
	or
X	Mounting Plate, Cleated Belt (2x)

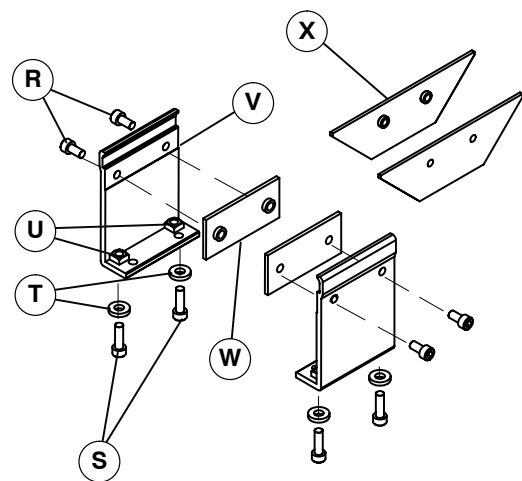

Figure 8

2. Attach clamp plate (W or X of Figure 8) to stand mounting bracket (V) with two screws (R). Do not tighten screws.

Installation

- Attach stand mounting bracket (V of Figure 9) to bottom of conveyor (Y). Snug-up screws (R).

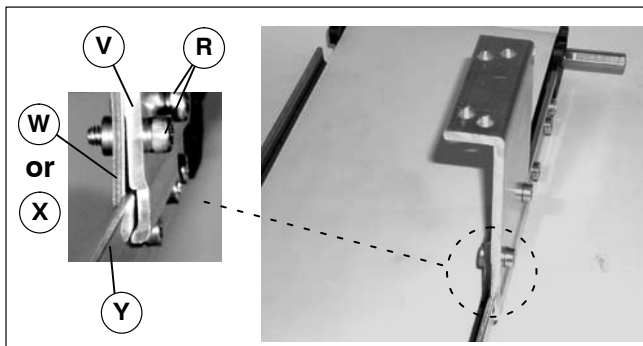

Figure 9

- Repeat steps 2 and 3 for other stand mounting bracket(s).
- Position conveyor (Y of Figure 10) on stands (Z).

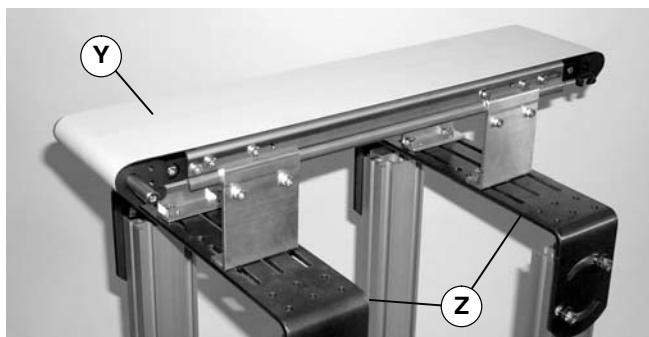

Figure 10

- Attach stand mounting bracket (V of Figure 11) to stand (Z) with two screws (S), hard washers (T) and square nuts (U). Tighten screws (S) to 80 in-lb (9 Nm).

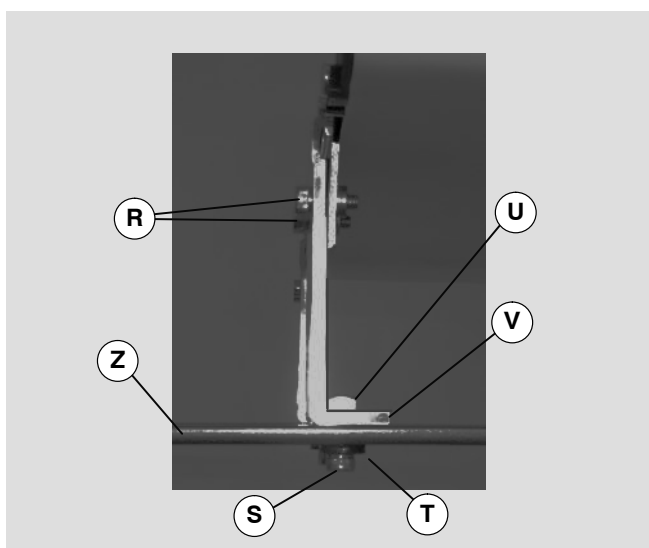

Figure 11

- Repeat step 6 for other stand mounting bracket(s).
- Tighten all screws (R) to 80 in-lb (9 Nm).

Return Rollers

2" to 6" (44 mm to 152 mm) Wide Conveyor

NOTE: No return rollers are required on conveyor lengths up to 7 ft (2134 mm). Use one pair of rollers centered between the idler and drive spindles on 8–15 ft (2438–4572 mm) conveyors. Use two pairs of rollers at one third distances between the idler and drive spindles on 16–18 ft (4877–5486 mm) conveyors.

- Typical return roller components (Figure 12)

Typical Components	
AA	Return Roller Guard
AB	Return Roller Clip (Flat Belt)
AC	Low-Head Cap Screw M6-1.00 x 20mm (2)
AD	Return Roller Clip (Cleated Belt)

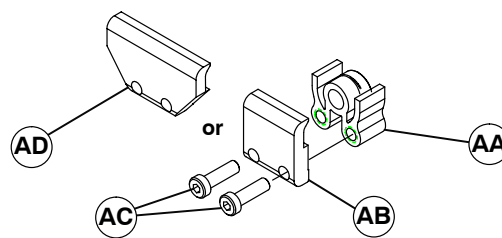

Figure 12

- Loosely attach clip (AB or AD of Figure 13) on guard (AA) with two screws (AC). Do not tighten screws.

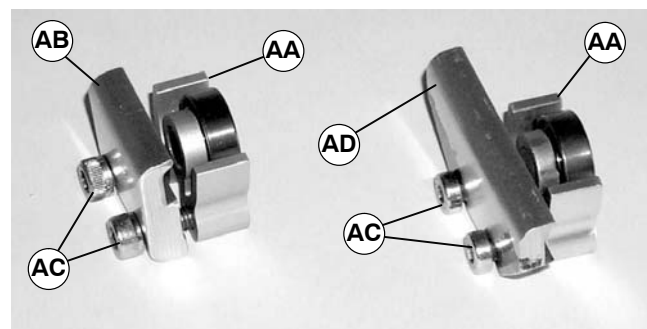

Figure 13

- Attach return roller assembly (AE of Figure 14) on each side of conveyor (Y). Tighten screws (AC) to 80 in-lb (9 Nm).

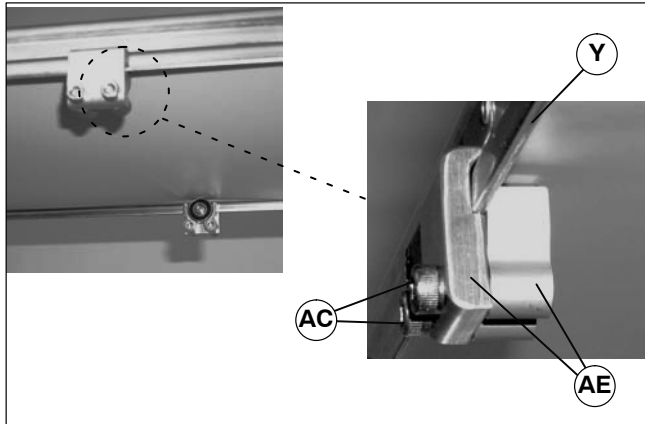

Figure 14

- On 8–18 ft (2338–5486 mm) conveyor, repeat step 3 as necessary for other return rollers.

8" to 18" (203 mm to 457 mm) Wide Flat Belt Conveyors

NOTE: No return rollers are required on conveyor lengths up to 7 ft (2134 mm). Use one roller centered between the idler and drive spindles on 8–15 ft (2438–4572 mm) conveyors. Use two rollers at one third distances between the idler and drive spindles on 16–18 ft (4877–5486 mm) conveyors.

- Typical return roller components (Figure 15)

Typical Components	
AF	Return Roller and Guard Assembly
AG	Return Roller Clip (2x)
AH	Low-Head Cap Screw M6–1.00 x 20mm (4x)

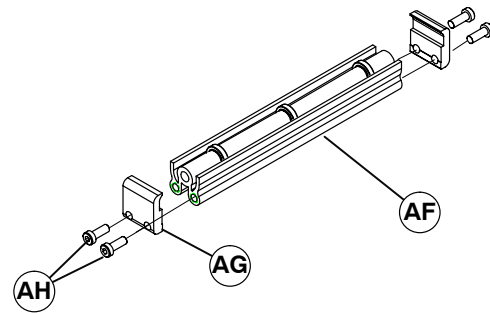

Figure 15

- Loosely attach two clips (AG of Figure 16) on roller and guard assembly (AF) with four screws (AH). Do not tighten screws.

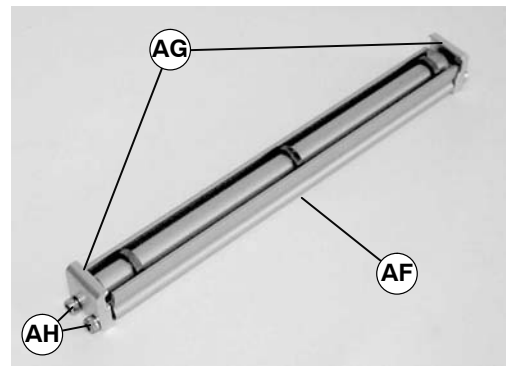

Figure 16

- Attach return roller assembly (AI of Figure 17) on conveyor (Y). Tighten screws (AH of Figure 16) to 80 in-lb (9 Nm).



Figure 17

- On 16–18 ft (4877–5486 mm) conveyor, repeat step 3 for other return roller.

Preventive Maintenance and Adjustment

Required Tools

Standard Tools

- Hex key wrenches:
2 mm, 2.5 mm, 3 mm, 4 mm, 5 mm and 6 mm
- Manual grease gun
- Adjustable wrench
- Arbor press

Special Tools

- 450281 Sealed Bearing Removal Tool
- 450282 Sealed Bearing Installation Tool
- 2500M Tool Kit for Gang Drive Bearings

Checklist

- Keep service parts on hand (see “Service Parts” section for recommendations)
- Keep supply of belt cleaner (part # 625619)
- For optional gang-driven conveyors, keep supply of bearing grease [for 14 oz (397 gram) cartridge (part # 829-002) or for 14 oz (397 gram) can (part # 829-003)]
- Clean entire conveyor and knurled pulley while disassembled
- Replace worn or damaged parts

Lubrication

Conveyor with Standard 0.47” (12 mm) Diameter Output Shaft

No lubrication is required. Replace bearings if worn.

Conveyor with Optional Gang Drive Pulley



NOTE: Only drive pulley bearings require lubrication (refer to the following steps). For all other bearings, replace if worn.

1. Disassemble support (AJ of Figure 18) and remove hex shaft and shaft guard sections (AK).

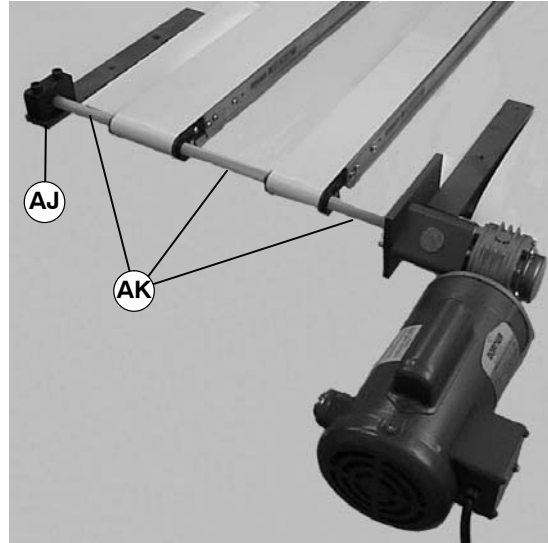

Figure 18

NOTE: Optional permanent grease fittings (part # 200398M) may be installed.

2. Install Dorner greasing adapter (part # 200046M) (AL of Figure 19). Make sure the adapter shoulder is seated against the conveyor tail plate.

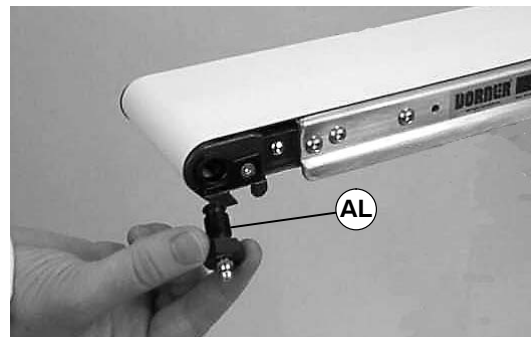

Figure 19

3. Use Dorner red grease, 14 oz (397 gram) cartridge (part #829-002) or 14 oz (397 gram) can (part # 829-003). Lubricate pulley bearing every 750 hours or more frequently, depending on operating conditions.

NOTE: Lubricate pulley bearing every 750 hours or more frequently, depending on operating conditions. When lubricating pulley bearings, use a conventional hand grease gun with a maximum of one pump per application. *Do not over-lubricate.* Do not use a power grease gun.

4. Grease bearing with one (1) pump from a manual grease gun. Do not over-lubricate.

Preventive Maintenance and Adjustment

5. Remove grease adapter and install on opposite side of pulley. Repeat steps 2 and 4.
6. Re-assemble hex shaft with guards and support (T of Figure 18).

Return Rollers

No lubrication is required. Replace bearings if worn.

Maintaining Conveyor Belt

Troubleshooting

Inspect conveyor belt for:

- Surface cuts or wear
- Stalling or slipping
- Damage to V-guide

Surface cuts and wear indicate:

- Sharp or heavy parts impacting belt
- Jammed parts
- Improperly installed bottom wiper(s)
- Accumulated dirt in wiper(s)
- Foreign material inside the conveyor
- Improperly positioned accessories
- Bolt-on guiding is pinching belt

Stalling or slipping indicates:

- Excessive load on belt
- Conveyor belt or drive timing belt are not properly tensioned
- Worn knurl or impacted dirt on drive pulley
- Intermittent jamming or drive train problems

Damage to V-guide indicates:

- Twisted or damaged conveyor frame
- Dirt impacted on pulleys
- Excessive or improper side loading

NOTE: Visit www.dorner.com for complete list of troubleshooting solutions.

Cleaning

IMPORTANT: Do not use belt cleaners that contain alcohol, acetone, Methyl Ethyl Ketone (MEK) or other harsh chemicals.

Use Dorner Belt Cleaner (part # 625619). Mild soap and water may also be used. Do not soak the belt.

For /05 woven polyester and /06 black anti-static belts, use a bristled brush to improve cleaning.

Conveyor Belt Replacement



Conveyor Belt Replacement Sequence (see Table of Contents for page number)

- Remove old conveyor belt
 - Conveyor without Gearmotor Mounting Package or Stands
 - Conveyor with Stands and/or Gearmotor Mounting Package
 - Conveyor with Optional Gang Drive Pulley
- Install new conveyor belt
- Tension conveyor belt

Belt Removal for Conveyor Without Gearmotor Mounting Package or Stands

1. If installed, remove and retain bottom wiper(s) (AM of Figure 20).

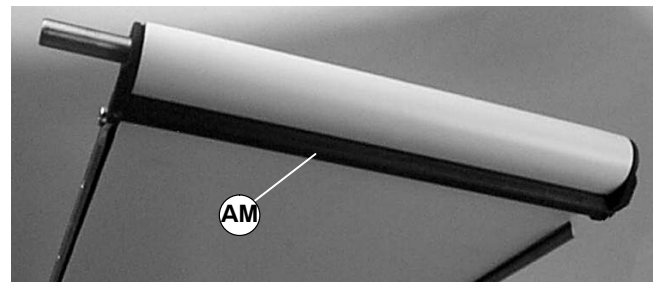



Figure 20

2. If conveyor is equipped with guiding and accessories or return rollers, remove them as necessary.

3. On tension end of the conveyor identified with a  label (AN of Figures 21 and 22), loosen four M6 socket head cap screws (AO).

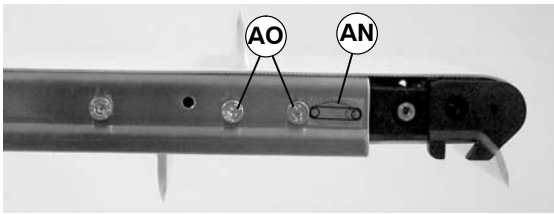

Figure 21

4. Retract idler spindle assembly (AP of Figure 22) by pushing in on it or by turning M6 pinion screw (AQ of Figures 22 and 23) clockwise.

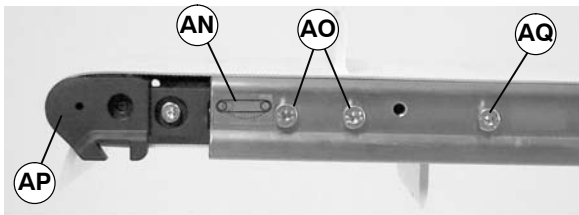

Figure 22

5. Remove conveyor belt (AR of Figure 23).

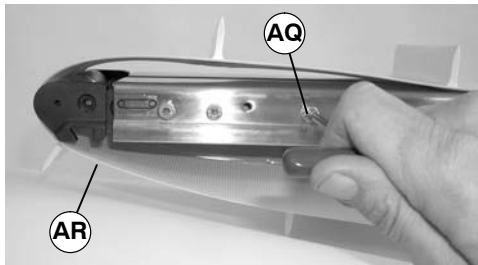

Figure 23

Belt Removal for Conveyor With Stands and/or Gearmotor Mounting Package

NOTE: For conveyor with a Heavy Load Bottom or Top Mount Package, bracket (AT of Figure 24) must be removed.

- Remove two M6x16 mm socket head screws (AS).
- Remove two M6x12 mm socket head screws (AU).
- Remove bracket (AT).

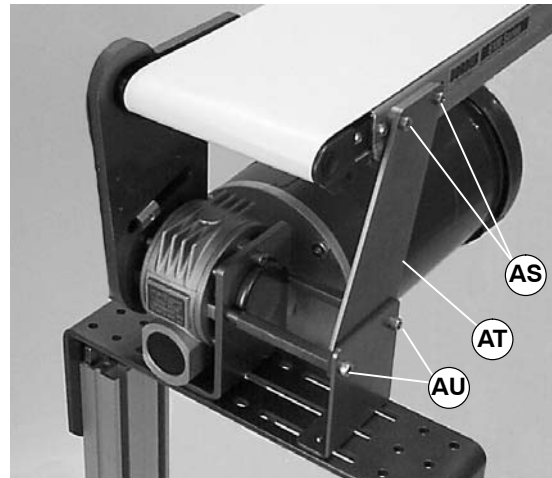



Figure 24

1. If installed, remove and retain bottom wiper(s) (AM of Figure 20).
2. If conveyor is equipped with guiding and accessories or return rollers, remove them as necessary.
3. On tension end of the conveyor identified with a  label (AN of Figures 21 and 22), loosen four M6 socket head cap screws (AO).
4. Retract idler spindle assembly (AP of Figure 22) by pushing it in or by turning M6 pinion screw (AQ of Figures 22 and 23) clockwise.

	WARNING	
<p>The weight of the gearmotor is all on one end of the conveyor which could cause it to tip off the stands when the mounting clamp plates are loosened. Be sure to provide support (AV of Figure 25) underneath the gearmotor while changing the belt.</p>		

Preventive Maintenance and Adjustment

5. Place a temporary support (AV of Figure 25) under gearmotor mounting package.

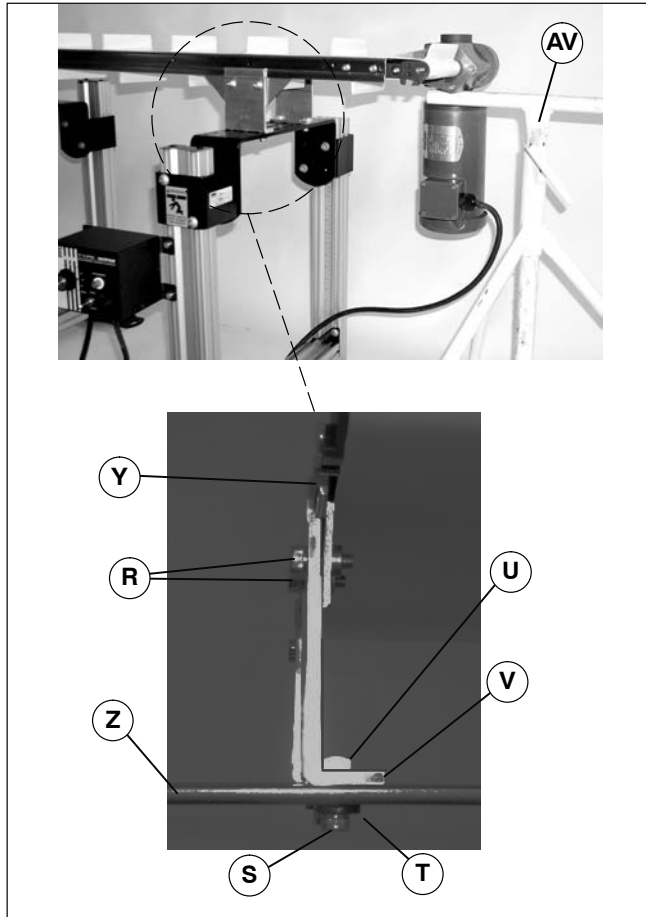

Figure 25

6. Loosen two mounting plate screws (R of Figure 25). Remove two screws (S), hard washers (T) and square nuts (U). Slide stand mounting bracket (V) off stand (Z) and remove from conveyor (Y).
7. Repeat step 6 for remaining stand mounting brackets on same side of conveyor.
8. Remove conveyor belt (AR of Figure 26).

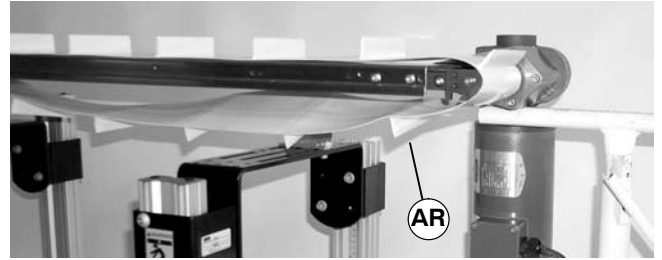



Figure 26

9. If a new belt will not be installed immediately, secure conveyor with mounting plate(s) and stand mounting bracket(s) (V of Figure 25).

Belt Removal for Conveyor With Optional Gang Drive Pulley

1. Disassemble support (AJ of Figure 18) and remove the hex shaft and shaft guard sections (AK).
2. If installed, remove and retain bottom wiper(s) (AM of Figure 20).
3. If conveyor is equipped with guiding and accessories or return rollers, remove them as necessary.
4. On tension end of the conveyor identified with a  label (AN of Figures 21 and 22), loosen four M6 socket head cap screws (AO).
5. Retract idler spindle assembly (AP of Figure 22) by pushing it in or by turning M6 pinion screw (AQ of Figures 22 and 23) clockwise.
6. Remove conveyor belt (AR of Figure 23).

Belt Installation for Conveyor without Gearmotor Mounting Package or Stands

IMPORTANT: On a flat belt conveyor, the wiper is installed on discharge end. Belt travel direction is identified by an arrow decal on the side of the conveyor (AW of Figure 27). With a reversing gearmotor, a second bottom wiper must be installed on opposite end.

Preventive Maintenance and Adjustment

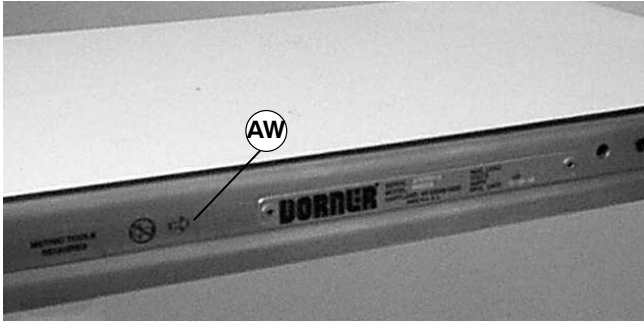

Figure 27

1. Orient the conveyor belt so that the splice leading fingers (AX of Figure 28) point in the direction of belt travel (AY) as identified by the label (AW of Figure 27).

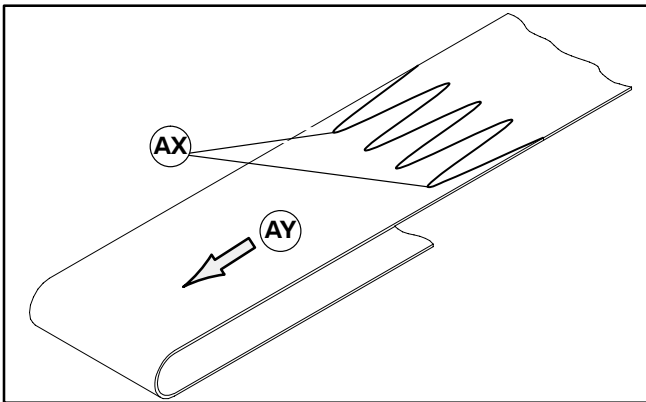

Figure 28

2. Slide belt (AR of Figure 23) onto the conveyor frame assembly.
3. On a flat belt conveyor, install bottom wiper(s) (AM of Figure 20). Center set screws in frame and tighten to 33 in-lb (3.7 Nm).
4. Tension belt. Refer to “Conveyor Belt Tensioning” on page 12.
5. Where applicable, install return rollers, guiding and accessories.

Belt Installation for Conveyor with Gearmotor Mounting Package and/or Stands

1. Orient conveyor belt so that the splice leading fingers (AX of Figure 28) point in the direction of belt travel (AY) as identified by the label (AW of Figure 27).
2. Slide belt (AR of Figure 23) onto conveyor frame assembly.

3. Install stand mounting bracket (V of Figure 25) onto stand (Z) and conveyor (Y). Refer to “Mounting Brackets” on page 5.
4. Repeat step 3 for remaining stand mounting brackets on same side of conveyor.
5. If removed, install bottom wiper(s) (W of Figure 20). Center set screws in frame and tighten to 33 in-lb (3.7 Nm).
6. For a conveyor with a Heavy Load Bottom or Top Mounting package, re-install bracket (AT of Figure 24).
7. Tension belt. Refer to “Conveyor Belt Tensioning” on page 12.
8. Where applicable, install return rollers, guiding and accessories.

Belt Installation for Conveyor With Optional Gang Drive Pulley

1. Orient the conveyor belt so that the splice leading fingers (AX of Figure 28) point in the direction of belt travel (AY) as identified by the label (AW of Figure 27).
2. Slide belt (AR of Figure 23) onto the conveyor frame assembly.
3. If removed, install bottom wiper(s) (W of Figure 20). Center set screws in frame and tighten to 33 in-lb (3.7 Nm).
4. Tension belt. Refer to “Conveyor Belt Tensioning” on page 12.
5. Where applicable, install return rollers, guiding and accessories.
6. Re-assemble hex shaft with guards sections (AK of Figure 18). Re-assemble support (AJ).

Conveyor Belt Tensioning

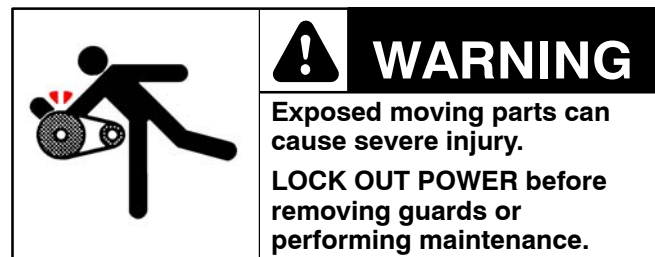

1. On tension end of the conveyor identified with a  label (AN of Figures 21 and 22), loosen four M6 low head screws (AO).

Preventive Maintenance and Adjustment

NOTE: The M6 low head screw (AZ of Figure 29), which is used for extending the idler spindle assembly to tension the belt, has a yellow colored head.

Do not exceed a torque of 25 in-lb (2.8 Nm) for 2" to 12" (44 mm to 305 mm) wide conveyors or 40 in-lb (4.5 Nm) for an 18" (457 mm) wide conveyor on this screw. Over-tensioning the conveyor belt could cause excessive pulley bearing load and early failure.

- 2a. For an existing belt, extend idler spindle assembly (AP of Figure 29) by turning M6 low head screw (AZ) clockwise to sufficiently tension belt to handle conveyor load.
- 2b. For a new belt, extend idler spindle assembly (AP of Figure 29) 1" (25 mm) (BA) by turning M6 low head screw (AZ) clockwise.

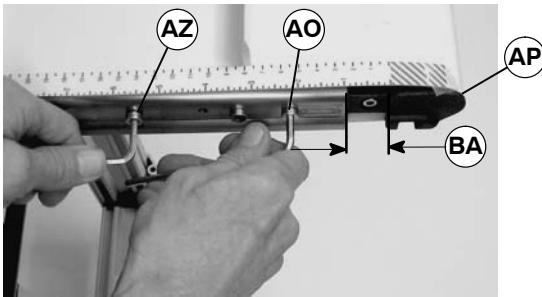
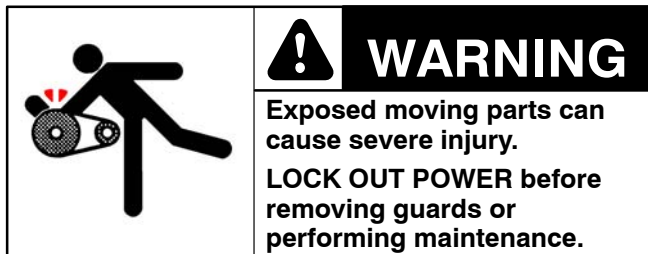

Figure 29

3. Tighten four M6 low head screws (AO of Figures 21, 22 and 29) to 40 in-lb (4.5 Nm) to secure idler spindle assembly (AP).

NOTE: If the maximum take-up stroke is achieved, replace the conveyor belt.

Pulley Removal



Remove conveyor belt to access pulley(s). See "Conveyor Belt Replacement" on page 9. Remove the desired pulley following instructions:

- A – Drive Pulley with Standard 0.47" (12 mm) Diameter Output Shaft
- B – Idler Pulley

- C – Gang Drive Pulley

A – Removal of Drive Pulley with Standard 0.47" (12 mm) Diameter Output Shaft



1. Remove the gearmotor mounting package. See accessory instructions.
2. For 10" (254 mm), 12" (305 mm) or 18" (457 mm) wide conveyors, remove key (BB of Figure 30) and two M5 low head screws (BC) to remove outboard bearing (BD).

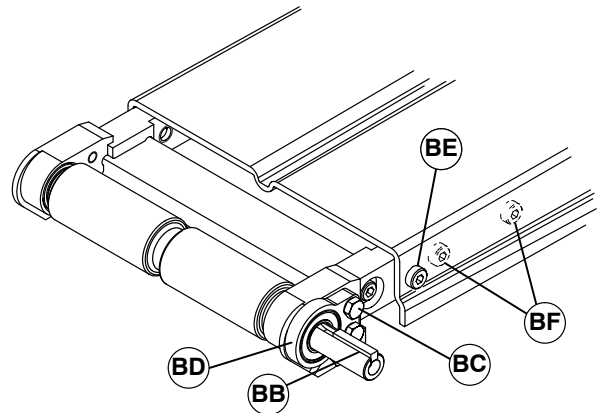

Figure 30

NOTE: Two screws (BF of Figure 30) were removed in step 1.

3. Remove screw (BE) on drive shaft side of conveyor.
4. Remove three (3) screws (BG of Figure 31) on side opposite of drive shaft.
5. Remove drive spindle assembly (BH).

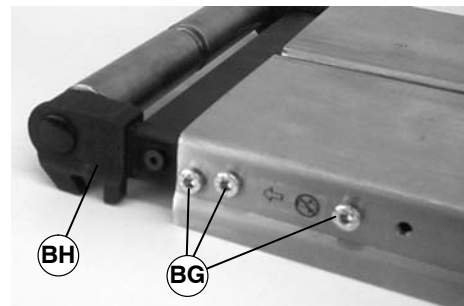

Figure 31

6. Remove screw (BI of Figure 32).
7. Remove headplate (BJ).
8. Remove pulley (BK).

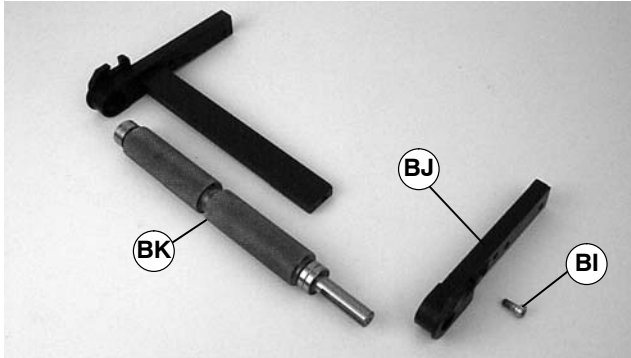

Figure 32

B – Idler Pulley Removal

1. Remove two screws (AO of Figure 33) on each side of conveyor.

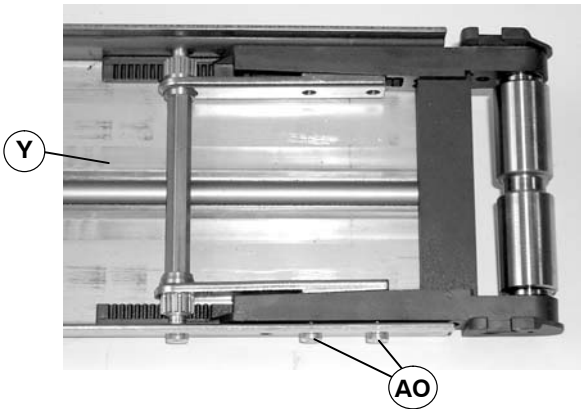

Figure 33

2. Loosen two screws (AQ and AZ of Figure 34).

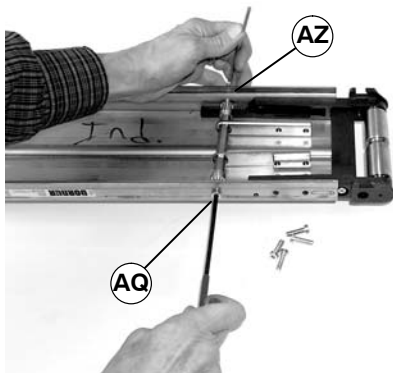

Figure 34

3. Remove two screws (AQ and AZ of Figure 35) and sleeves (BL) from conveyor (Y) and hex pinion (BM).

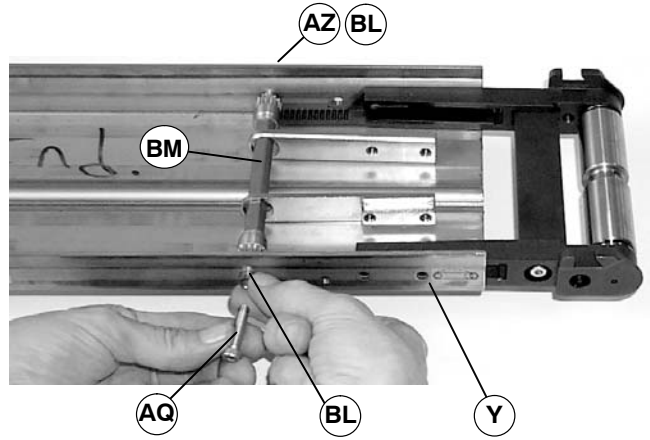

Figure 35

4. Remove two pinion ends (BN of Figure 36), clamp blocks (BO), hex pinion (BM) and tail assembly (BP) from conveyor (Y).

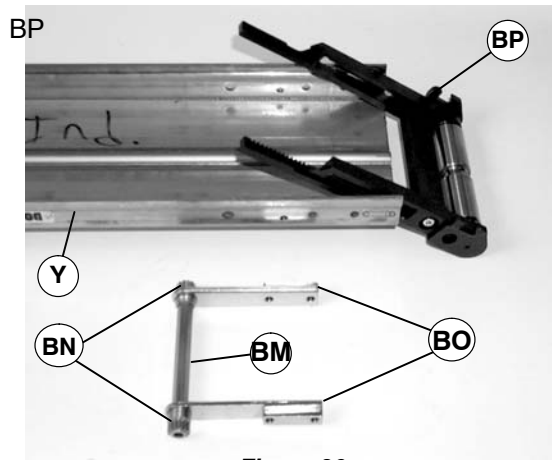

Figure 36

NOTE: Note which side of conveyor magnet (BQ of Figure 37) is located.

5. Locate magnet (BQ of Figure 37) on spindle and bearing assembly (BR).

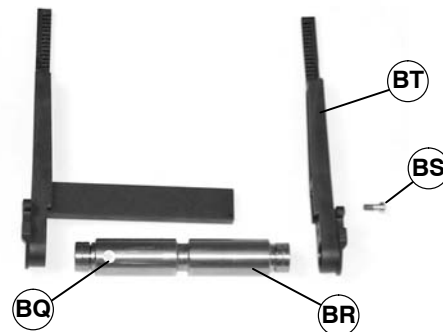

Figure 37

Preventive Maintenance and Adjustment

6. Remove screw (BS), headplate (BT), and spindle and bearing assembly (BR).

C – Gang Drive Pulley Removal

☆ - Parts required from Tool Kit, part number 2500M.

1. Remove two M5 low head screws (BU of Figure 38) and clip (BV) from head plate (BW).

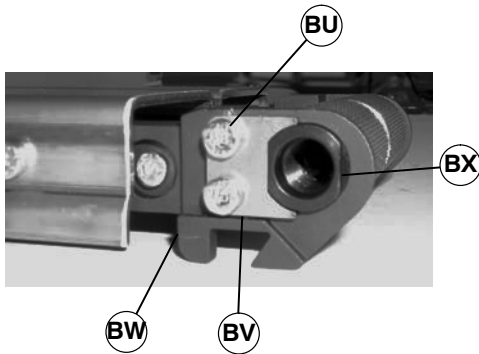

Figure 38

2. Repeat step 1 for opposite side.
3. Install bolt (part # 906-278☆) (BY of Figure 39) into retaining sleeve (BX). Pull out on bolt to remove retaining sleeve.

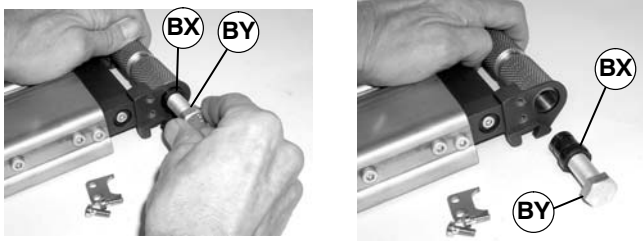

Figure 39

4. Repeat step 3 for opposite side.

NOTE: If retaining sleeve(s) (BX of Figure 38 and 39) does not slide out::

- Remove tail assembly following steps 3, 4 and 5 of Removal of Drive Pulley with Standard 0.47" (12 mm) Diameter Output Shaft on page 13
- Assemble removal tool (part # 25-09☆) (BZ of Figure 40) and bolt (part # 906-278☆) (BY) on spindle (CA), as shown
- Tighten bolt (BY) to remove bearing sleeve (BX of Figure 38 and 39) from spindle (CA of Figure 40).

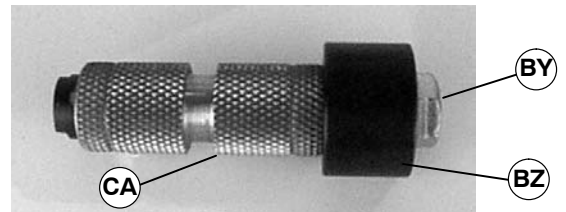

Figure 40

Bearing Replacement for Drive Pulley with Standard 0.47" (12 mm) Diameter Output Shaft or Idler Pulley

IMPORTANT: Once removed, do not re-use bearings.

Bearing Removal

1. Place bearing removal tool (part # 450281) (CC of Figure 41) over bearing (CD) with lip (CE) located in gap (CF) between bearing and spindle (CB) as shown.

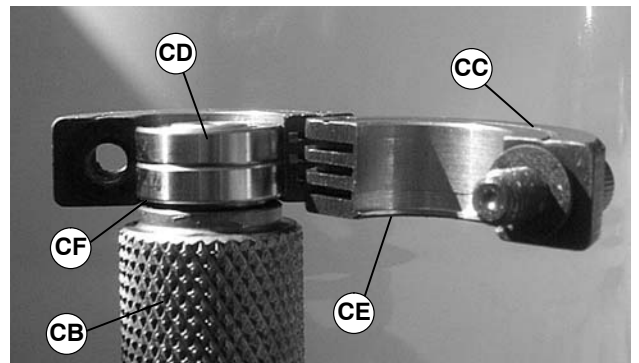

Figure 41

Preventive Maintenance and Adjustment

- Using 3/16" hex key wrench (CG of Figure 42), tighten bearing removal tool.



Figure 42

- Using a puller (CH of Figure 43), remove and discard bearing(s).

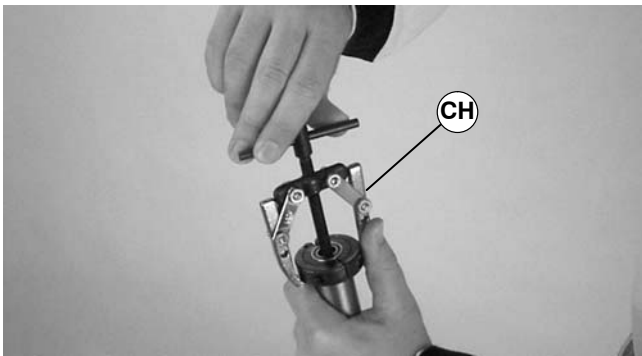

Figure 43

Bearing Installation

IMPORTANT: Install bearings one at a time.

- Inspect seating surface(s) for damage. Replace if damaged.
- Slide bearing (part # 802-121) (CI of Figure 44) onto pulley shaft.



Figure 44

- Slide the sleeve of tool (part # 450282) (CK of Figure 45) over bearing.

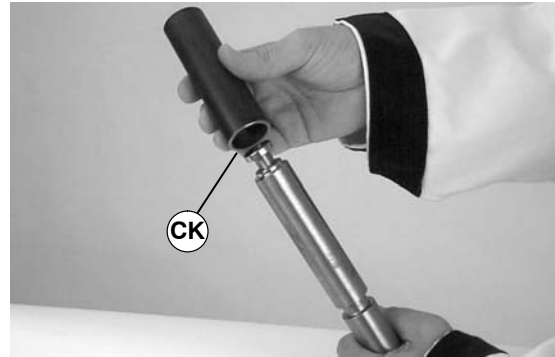

Figure 45

- Place open end of shaft (CL of Figure 46) into sleeve.

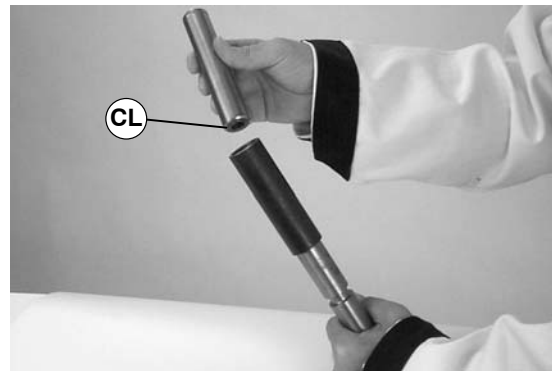

Figure 46

- Using arbor press or similar device, press bearing onto pulley shaft (see Figure 47).

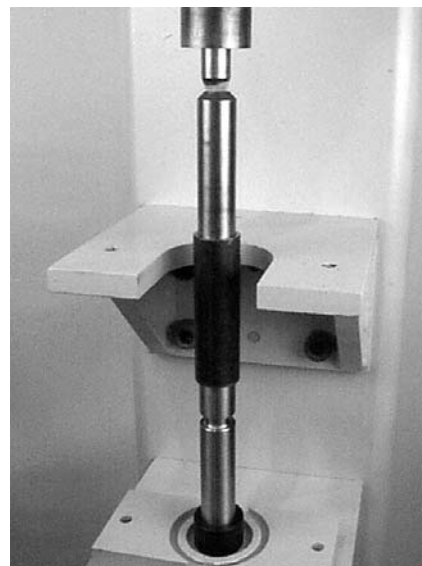

Figure 47

- Repeat steps 1 through 5 for each bearing.

Preventive Maintenance and Adjustment

Bearing Replacement for Gang Drive Pulley

☆ - Parts required from Tool Kit, part number 2500M.

IMPORTANT: Once removed, do not re-use bearings.

Bearing Removal

NOTE: The bearings of a 2" (51 mm) wide gang drive pulley cannot be replaced. Order pulley assembly (part # 454702).

1. Insert bearing removal tool (part # 25-05☆) (CN of Figure 48) into the pulley (CQ) until shoulder (CM) seats against bottom of bearing (CR).

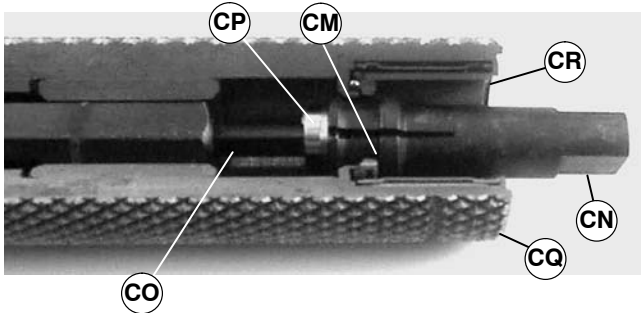

Figure 48

2. While holding bearing removal tool (CN) in position, insert extension tool (part # 25-08☆) (CO) into opposite end of pulley (CQ). Rotate bearing removal tool (CN) to engage hex tip of extension tool (CO) into screw (CP).
3. While maintaining extension tool (CO) position, use a wrench to rotate bearing removal tool (CN) to expand flare.

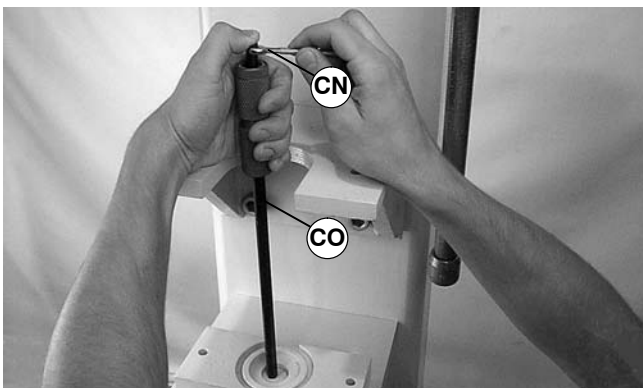

Figure 49

4. Orient bearing anvil/sleeve removal tool (part # 25-09☆) (CS of Figure 50) with cavity facing up and place pulley onto tool.

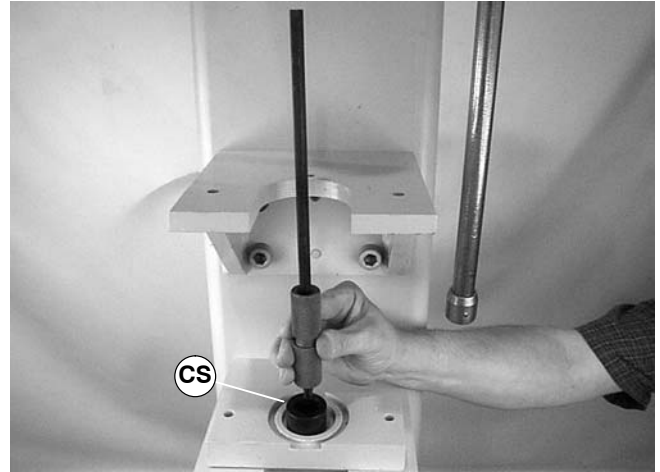

Figure 50

NOTE: If a severely worn bearing breaks apart during removal, pulley must be replaced.

5. Press bearing out of pulley.

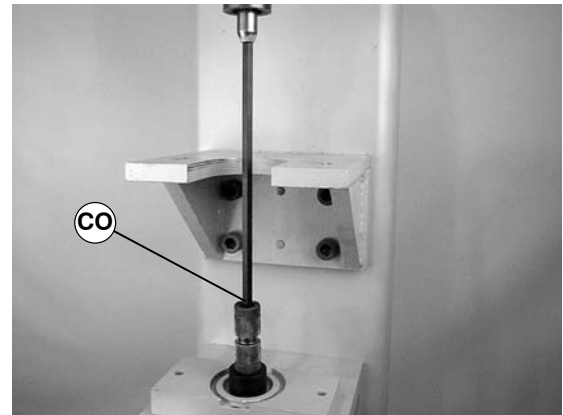

Figure 51

Preventive Maintenance and Adjustment

Bearing Installation

1. Orient bearing anvil/sleeve removal tool (part # 25-09☆) (CS of Figure 52) with cavity facing up and place pulley (CQ) onto tool.

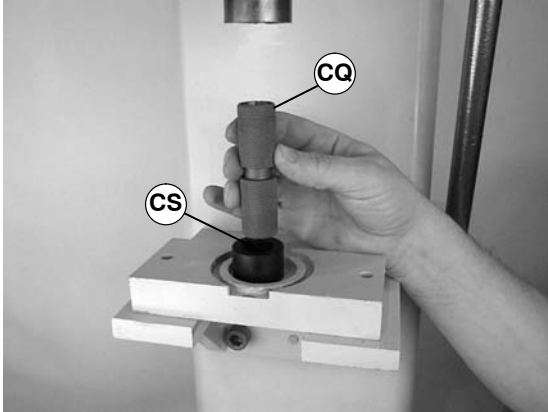

Figure 52

2. Install bearing insertion tool (part # 25-10☆) (CT of Figure 53) into arbor press or similar device.

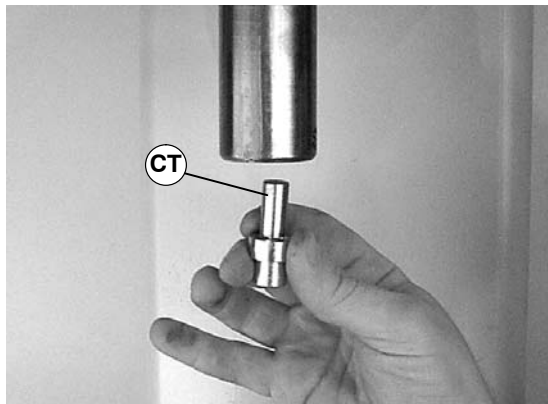

Figure 53

3. Place and hold bearing (part # 21-33) (CR) onto tool (CT).

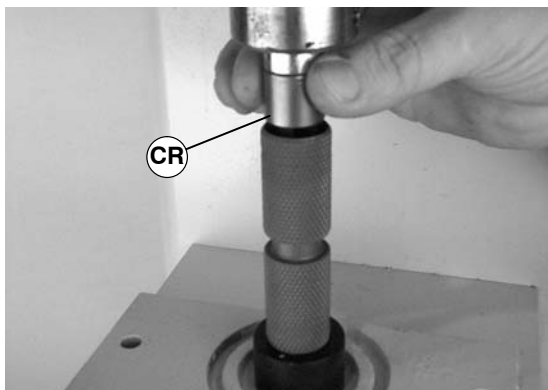

Figure 54

IMPORTANT: Bearing and pulley alignment is critical.

4. Press bearing (CR of Figure 55) into pulley (CQ) until seated.

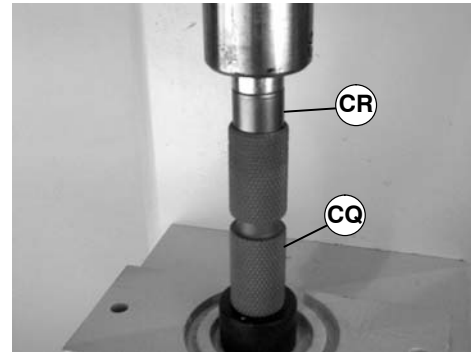

Figure 55

Pulley Replacement

Drive Pulley with Standard 0.47" (12 mm) Diameter Output Shaft Replacement

1. Reverse the removal procedure "A" (see page 13).

Idler Pulley Replacement

IMPORTANT: On a tension tail assembly, orient both pinion ends (BN of Figure 56) so they engage the same tooth positions on their respective racks.

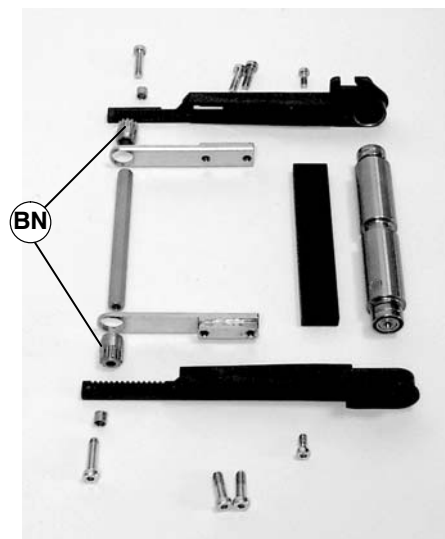

Figure 56

1. Reverse the removal procedure "B" (see page 13).

Preventive Maintenance and Adjustment

Gang Drive Pulley Replacement

1. Reverse the removal procedure “C” (see page 15).

IMPORTANT: When installing clips (BV of Figure 57), ensure step (CU) is toward head plate (BW).

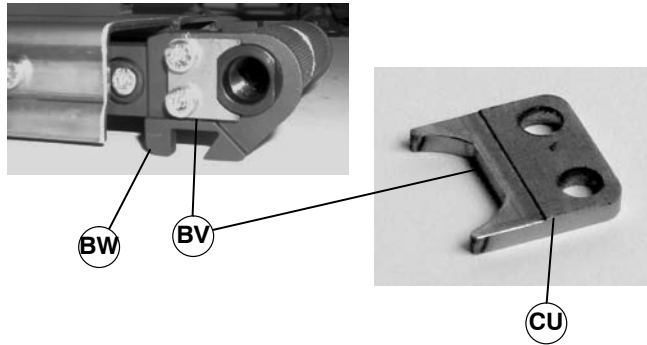

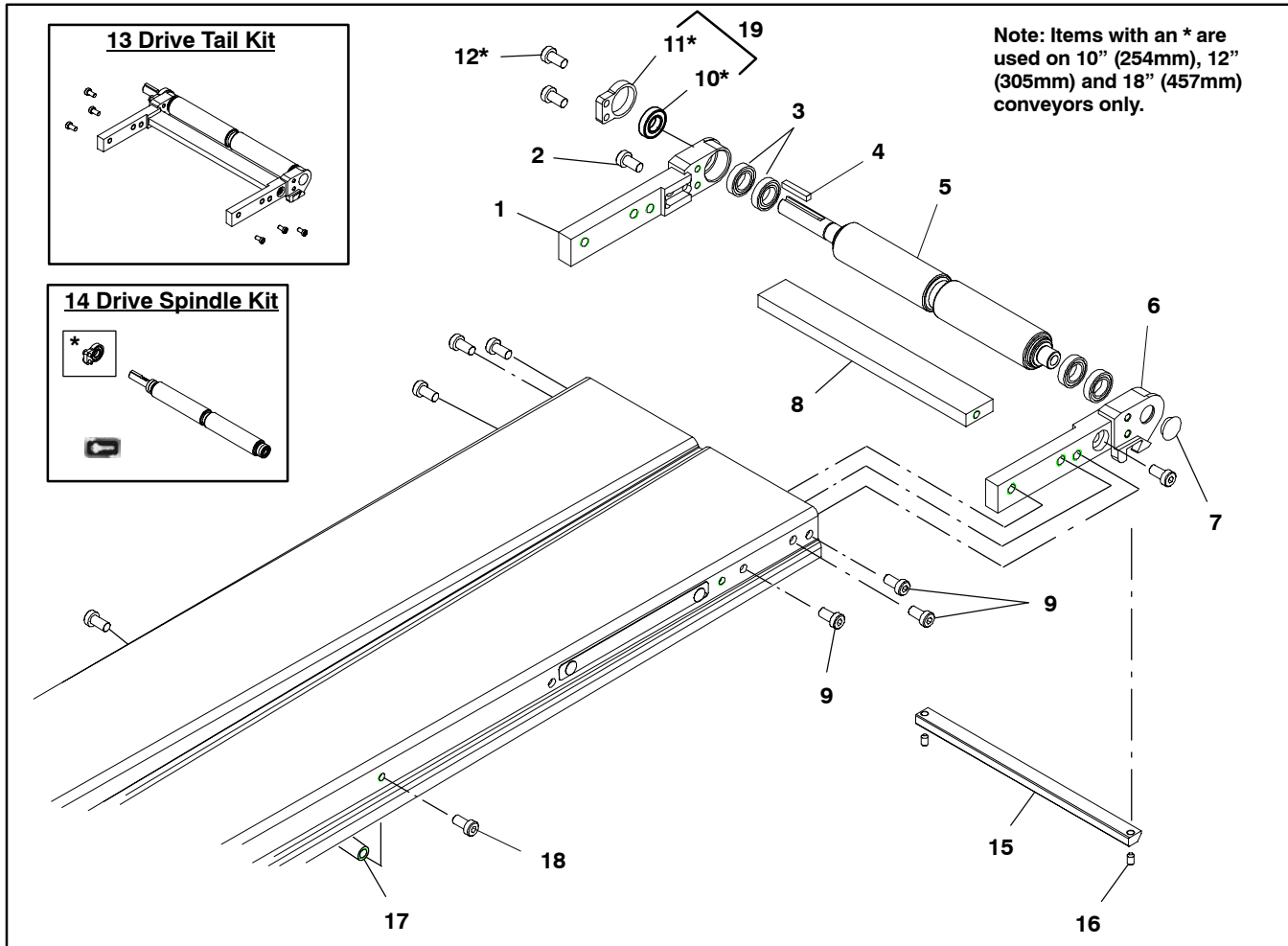

Figure 57

Service Parts

NOTE: For replacement parts other than those shown in this section, contact an authorized Dorner Service Center or the factory. Key Service Parts and Kits are identified by the Performance Parts Kits logo . Dorner recommends keeping these parts on hand.

Drive End Components



Item	Part Number	Description
1	456021	Head Plate LH 2-3" (51-76mm) Wide
	456022	Head Plate LH 4-18" (102-457mm) Wide
2	807-1022	Low-Head Pilot Screw M5-.8x12mm
3	802-121	Ball Bearing 12mm Bore x 21mm OD
4	980422M	Square Key 4mm x 22mm
5	4531WWW	Drive Spindle
6	456025	Head Plate RH 2-3" (51-76mm) Wide
	456026	Head Plate RH 4-18" (102-457mm) Wide
7	807-963	Plastic Snap-Out Plug
8	4536WWW	Support Tension/Fixed
9	920692M	Low-Head Cap Screw M6-1.0x12mm
10	802-148	Ball Bearing 12mm Bore x 24mm OD (used on 10" (254mm), 12" (305mm) and 18" (457mm) conveyors, only)
11	456032	Outboard Bearing Plate (used on 10" (254mm), 12" (305mm) and 18" (457mm) conveyors, only)

12	807-1022	Low-Head Pilot Screw M5-.8x12mm
13	62DTA-WWW	Drive Tail Kit - A & B Positions (Includes Items 1 through 11)
	62DTD-WWW	Drive Tail Kit - C & D Positions (Includes Items 1 through 11)
14	62D-WWW	Drive Spindle Kit (Includes Items 2 through 5, and if applicable, 10, 11 and 12)
15	4527WWW	Bottom Wiper
16	970508M	Cup-Point Set Screw M5-.80 x 8mm
17	4525WWW	Frame Support Post
18	807-1022	Low-Head Pilot Screw M5-.8x12mm
19	456033	Outboard Bearing Assembly (includes items 10 & 11)

WWW = Conveyor width ref.: 02, 03, 04, 05, 06, 08, 10, 12, 18

Tension End Components

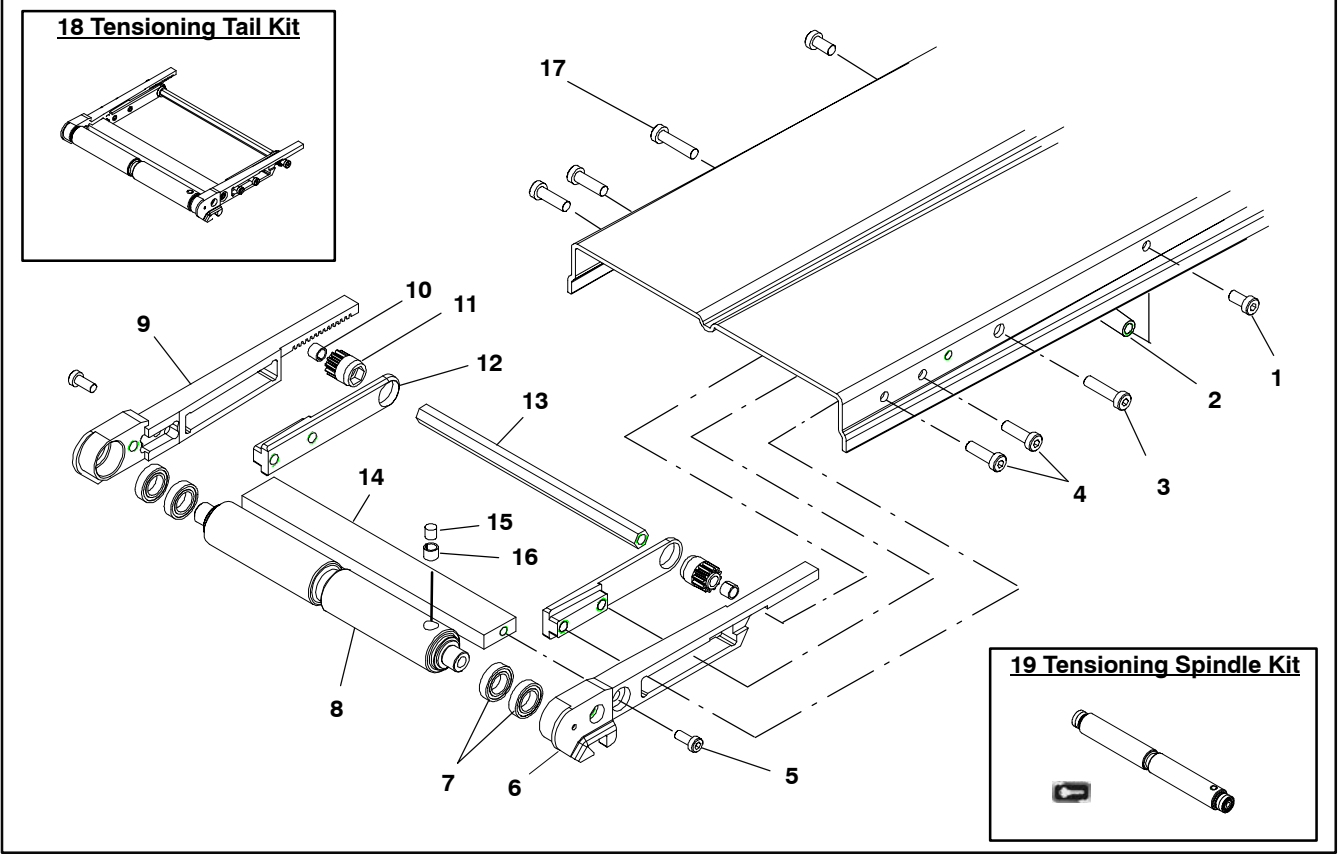

Item	Part Number	Description
1	920692M	Low-Head Cap Screw M6 x 12mm
2	4525WWM	Frame Support Post
3	920695M	Low-Head Cap Screw M6 x 25mm
4	920694M	Low-Head Cap Screw M6 x 20mm
5	807-1022	Low-Head Pilot Screw M5 x 12mm
6	456011	Head Plate Tension RH 2-3" (51-76mm) Wide
	456012	Head Plate Tension RH 4-18" (102-457mm) Wide
7	802-121	Ball Bearing 12mm Bore x 21mm OD
8	4530WW	Idler Spindle (includes ref. 16 & 17)
9	456014	Head Plate Tension LH 2-3" (51-76mm) Wide
	456015	Head Plate Tension LH 4-18" (102-457mm) Wide

10	456049	Sleeve .312 OD x .035 Wall
11	456045	Pinion End
12	456041	Clamp Block
13	4563WW	Hex Pinion
14	4536WW	Support Tension/Fixed
15	808-202	Magnet .25 x .25
16	450226SSP	SS Sleeve .25 Magnet
17	807-1317	Low-Head Cap Screw M6 x 12mm (Yellow)
18	62TT-WW	Tensioning Tail Kit (Includes Items 3 through 17)
19	62T-WW	Tensioning Spindle Kit (Includes Items 7, 8, 15 and 16)

WW = Conveyor width ref.: 02, 03, 04, 05, 06, 08, 10, 12, 18

Service Parts

Conveyor Frame and Extensions

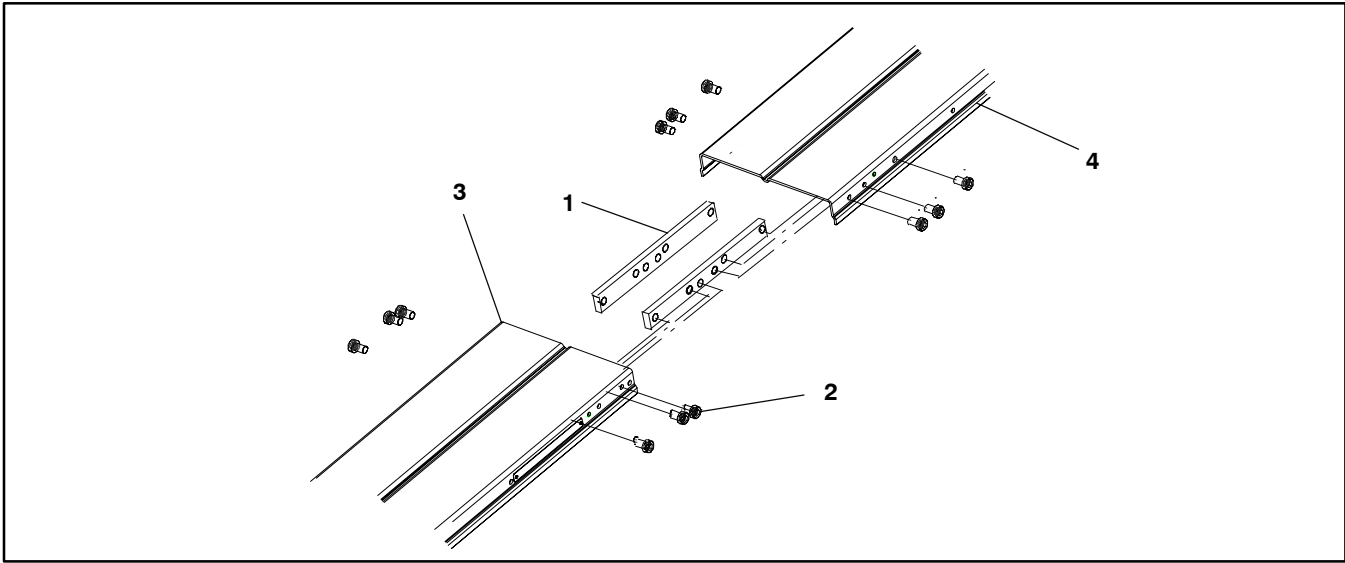

Item	Part Number	Description
1	450160M	Bar Connecting Frame
2	920691M	Low-Head Cap Screw M6-1.0x10mm

3	See Conveyor Frame chart	Conveyor Frame
4	See Conveyor Frame chart	Conveyor Frame Extension

Items 3 and 4: Conveyor Frame		
Length	Frame Part Number	Frame Extension Part Number
2' (610mm)	4720WW-01860	n/a
3' (914mm)	4720WW-03060	n/a
4' (1219mm)	4720WW-04260	n/a
5' (1524mm)	4720WW-05460	n/a
6' (1829mm)	4720WW-06660	n/a
7' (2134mm)	4720WW-07860	n/a
8' (2438mm)	4720WW-09060	n/a
9' (2743mm)	4720WW-10260	n/a
10' (3048mm)	4720WW-11460	n/a
11' (3353mm)	4720WW-12660	n/a
12' (3658mm)	4720WW-13860	n/a

13' (3962mm)	4720WW-07860	4740WW
14' (4267mm)	4720WW-09060	4740WW
15' (4572mm)	4720WW-10260	4740WW
16' (4877mm)	4720WW-11460	4740WW
17' (5182mm)	4720WW-12660	4740WW
18' (5486mm)	4720WW-13860	4740WW
19' (5791mm)	4720WW-07860	4741WW
20' (6096mm)	4720WW-09060	4741WW
21' (6401mm)	4720WW-10260	4741WW
22' (6706mm)	4720WW-11460	4741WW
23' (7011mm)	4720WW-12660	4741WW
24' (7316mm)	4720WW-13860	4741WW
WW = Conveyor width ref.: 02, 03, 04, 05, 06, 08, 10, 12, 18		

Gang Drive Thru-Shaft Option

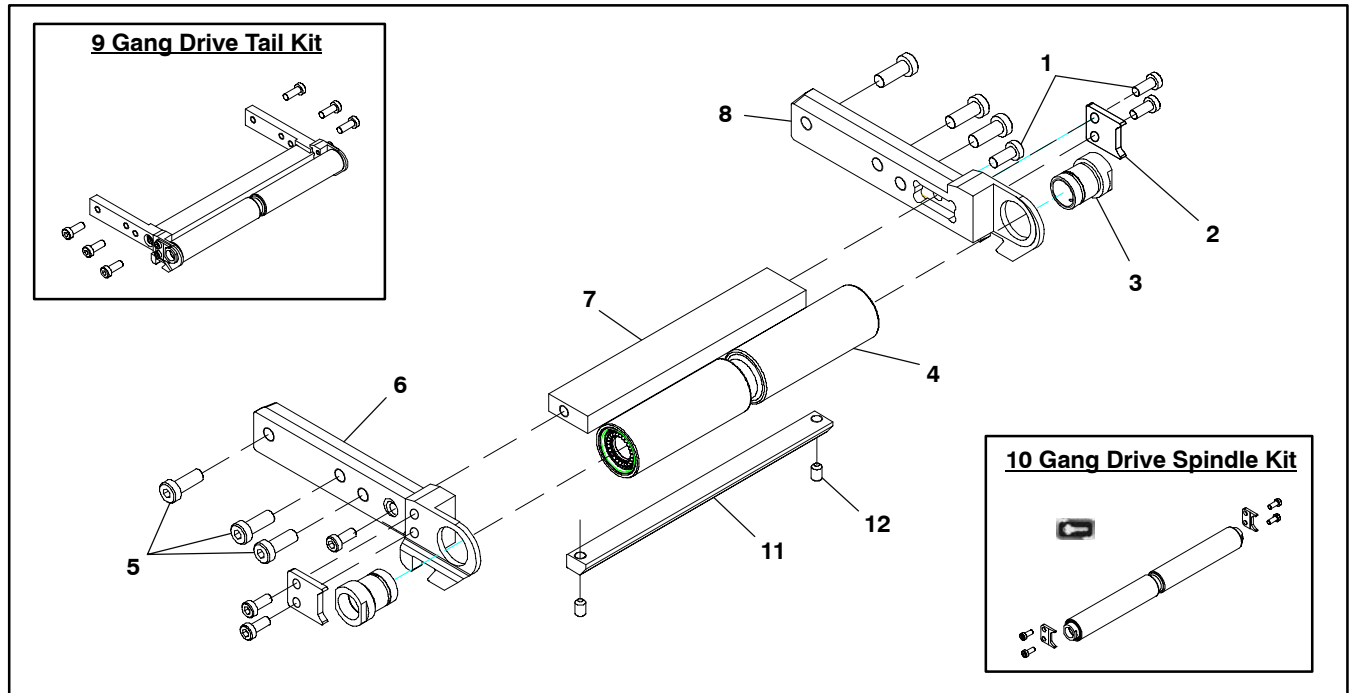

Item	Part Number	Description
1	807-1022	Low-Head Pilot Screw M5-.80 x 12mm
2	456028	Retaining Clip
	200035	Retaining Sleeve (3-18") (76-457mm)
3	677330	Retaining Sleeve (2") (51mm)
4	See Drive Spindle chart	Drive Spindle
5	920692M	Low-Head Cap Screw M6-1.0x12mm
6	456027	Fixed Plate RH
7	4536WWW	Tension Support Fixed
8	456023	Fixed Plate LH
9	62GDT- <u>WWW</u>	Gang Drive Tail Kit (Includes Items 1 through 8)
10	62GD- <u>WW</u>	Gang Drive Spindle Kit (Includes Items 1 through 4)
11	4527WWW	Thick Bottom Wiper 0.4970 Thick *
	4528WWW	Thin Bottom Wiper 0.4538 Thick **

12	970508M	Socket Head Set Screw M5-.80 x 8mm
<p>WWW = Conveyor width ref.: 02, 03, 04, 05, 06, 08, 10, 12, 18 * Use with belts /01, /02, /05, /06, /54, /56, /57, /59, /60, /61, /63, /66 ** Use with belts /03, /08, /55, /64</p>		

Item 4: Drive Spindle			
Spindle Width	Spindle assembly with bearings	Spindle without bearings	Bearings
2" (51mm)	454702	N/A	N/A
3" (76mm)	454703	454503	41-33
4" (102mm)	454704	454504	41-33
5" (127mm)	454705	454505	41-33
6" (152mm)	454706	454506	41-33
8" (203mm)	454708	454508	41-33
10" (254mm)	454710	454510	41-33
12" (305mm)	454712	454512	41-33
18" (457mm)	454718	454518	41-33

Service Parts

-02 0.5" (13mm) Bolt-On High Side Guides

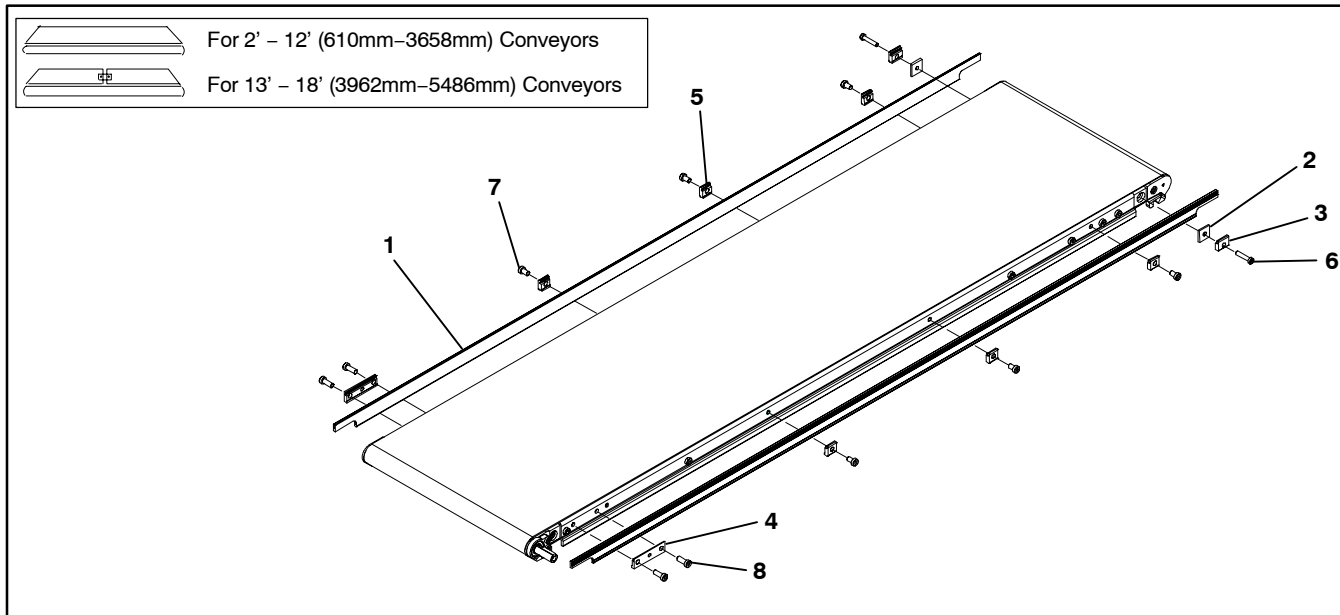

Item	Part Number	Description
1	See chart below	6200 Guide .5" (13mm) HS
2	460058	Spacer Guide Clip
3	460059	Clip Guide .75" long
4	460060	Guide Clip Spacer
5	460250	Clip Mounting Guide
6	807-1359	Low Head Pilot Screw, M5-.80 x 25mm
7	920691M	Low Head Cap Screw, M6-1.00 x 10mm
8	920693M	Low Head Cap Screw, M6-1.00 x 16mm

6200 Guide .5" (13mm) HS			
Length		End Guide	End Guide
2' (610mm)	Left Hand	460055-02400	N/A
	Right Hand	460055-02400	N/A
3' (914mm)	Left Hand	460055-03600	N/A
	Right Hand	460055-03600	N/A
4' (1219mm)	Left Hand	460055-04800	N/A
	Right Hand	460055-04800	N/A
5' (1524mm)	Left Hand	460055-06000	N/A
	Right Hand	460055-06000	N/A
6' (1829mm)	Left Hand	460055-07200	N/A
	Right Hand	460055-07200	N/A
7' (2134mm)	Left Hand	460055-08400	N/A
	Right Hand	460055-08400	N/A

8' (2438mm)	Left Hand	460055-09600	N/A
	Right Hand	460055-09600	N/A
9' (2743mm)	Left Hand	460055-10800	N/A
	Right Hand	460055-10800	N/A
10' (3048mm)	Left Hand	460055-12000	N/A
	Right Hand	460055-12000	N/A
11' (3353mm)	Left Hand	460055-13200	N/A
	Right Hand	460055-13200	N/A
12' (3658mm)	Left Hand	460055-14400	N/A
	Right Hand	460055-14400	N/A
13' (3962mm)	Left Hand	460255-08139	460255-07460
	Right Hand	460155-08139	460155-07460
14' (4267mm)	Left Hand	460255-09339	460255-07460
	Right Hand	460155-09339	460155-07460
15' (4572mm)	Left Hand	460255-10539	460255-07460
	Right Hand	460155-10539	460155-07460
16' (4877mm)	Left Hand	460255-11739	460255-07460
	Right Hand	460155-11739	460155-07460
17' (5182mm)	Left Hand	460255-12939	460255-07460
	Right Hand	460155-12939	460155-07460
18' (5486mm)	Left Hand	460255-14139	460255-07460
	Right Hand	460155-14139	460155-07460

-03 Bolt-On Side Wipers

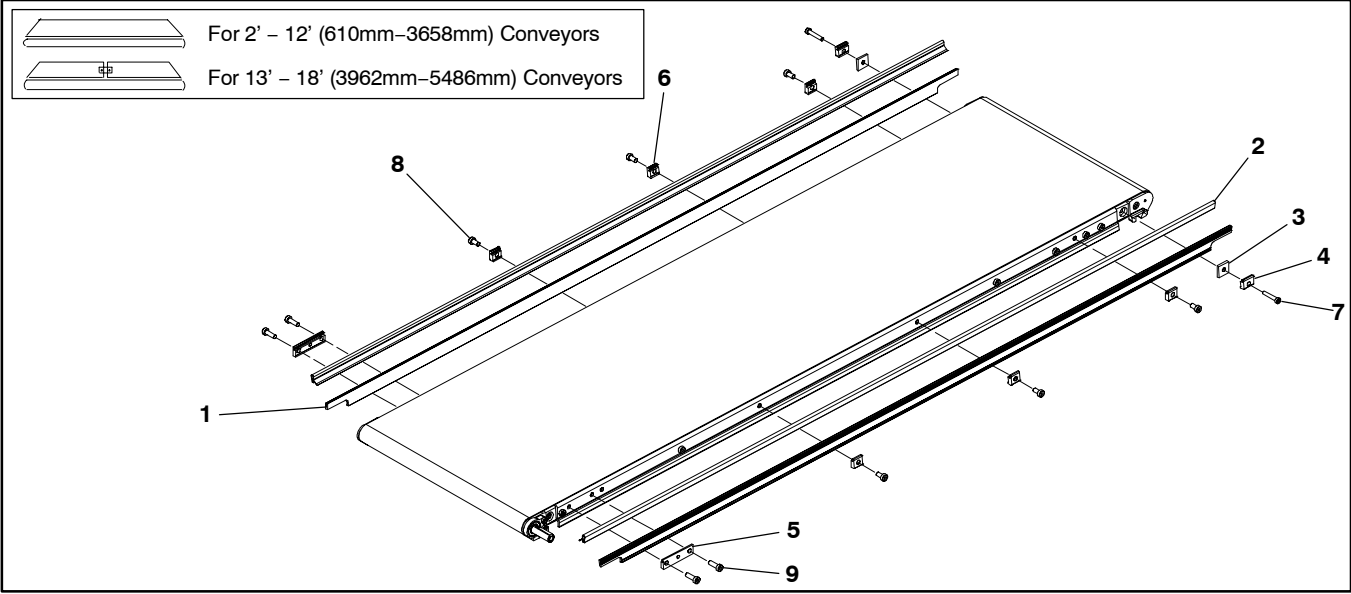

Item	Part Number	Description
1	See chart below	6200 Guide .5" (13mm) HS
2	41-00-24	Wiper Side Nylatron (per foot)
3	460058	Spacer Guide Clip
4	460059	Clip Guide .75" long
5	460060	Guide Clip Spacer
6	460250	Clip Mounting Guide
7	807-1359	Low Head Pilot Screw, M5-.80 x 25mm
8	920691M	Low Head Cap Screw, M6-1.00 x 10mm
9	920693M	Low Head Cap Screw, M6-1.00 x 16mm

7' (2134mm)	Left Hand	460055-08400	N/A
	Right Hand	460055-08400	N/A
8' (2438mm)	Left Hand	460055-09600	N/A
	Right Hand	460055-09600	N/A
9' (2743mm)	Left Hand	460055-10800	N/A
	Right Hand	460055-10800	N/A
10' (3048mm)	Left Hand	460055-12000	N/A
	Right Hand	460055-12000	N/A
11' (3353mm)	Left Hand	460055-13200	N/A
	Right Hand	460055-13200	N/A
12' (3658mm)	Left Hand	460055-14400	N/A
	Right Hand	460055-14400	N/A
13' (3962mm)	Left Hand	460255-08139	460255-07460
	Right Hand	460155-08139	460155-07460
14' (4267mm)	Left Hand	460255-09339	460255-07460
	Right Hand	460155-09339	460155-07460
15' (4572mm)	Left Hand	460255-10539	460255-07460
	Right Hand	460155-10539	460155-07460
16' (4877mm)	Left Hand	460255-11739	460255-07460
	Right Hand	460155-11739	460155-07460
17' (5182mm)	Left Hand	460255-12939	460255-07460
	Right Hand	460155-12939	460155-07460
18' (5486mm)	Left Hand	460255-14139	460255-07460
	Right Hand	460155-14139	460155-07460

6200 Guide .5" (13mm) HS			
Length		End Guide	End Guide
2' (610mm)	Left Hand	460055-02400	N/A
	Right Hand	460055-02400	N/A
3' (914mm)	Left Hand	460055-03600	N/A
	Right Hand	460055-03600	N/A
4' (1219mm)	Left Hand	460055-04800	N/A
	Right Hand	460055-04800	N/A
5' (1524mm)	Left Hand	460055-06000	N/A
	Right Hand	460055-06000	N/A
6' (1829mm)	Left Hand	460055-07200	N/A
	Right Hand	460055-07200	N/A

Service Parts

-04 3" (76 mm) Bolt - On High Side Guides

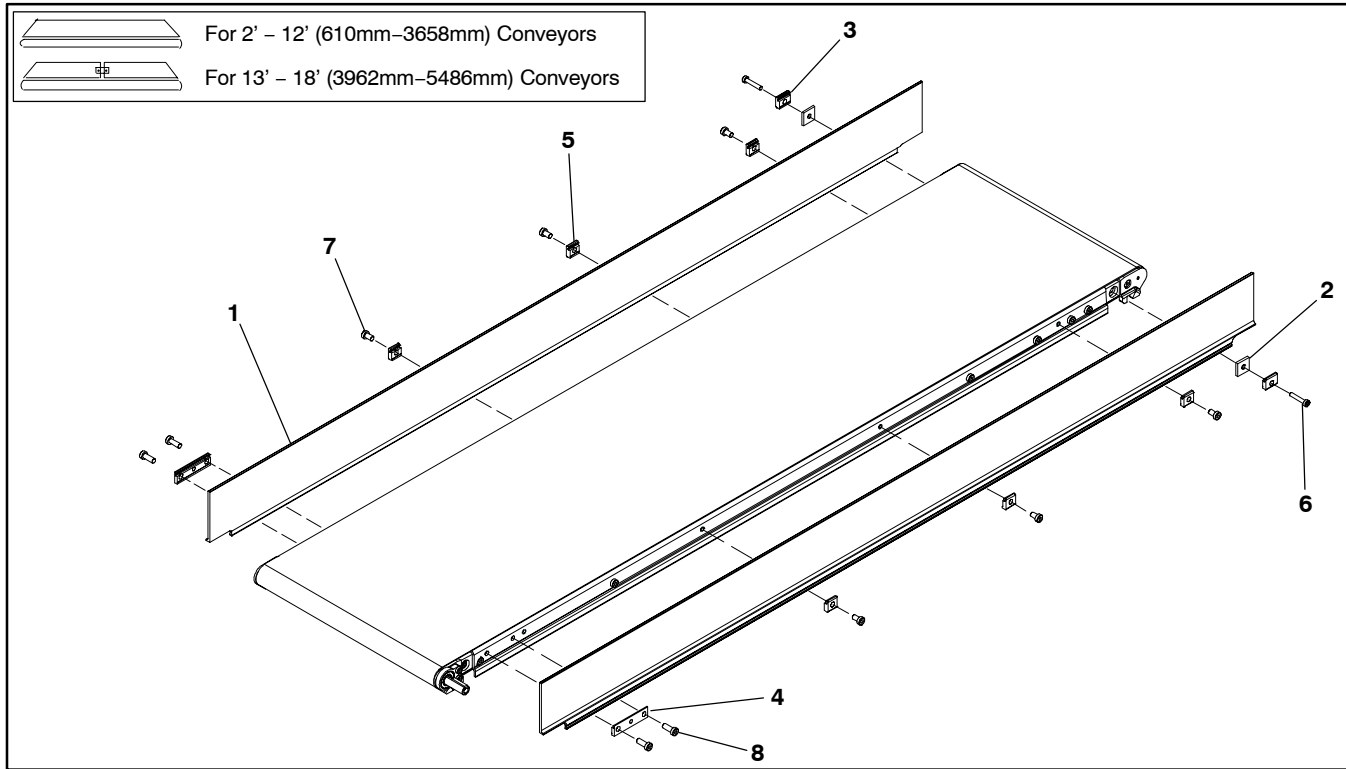

Item	Part Number	Description
1	See chart below	6200 Guide 3" (76mm) HS
2	460058	Spacer Guide Clip
3	460059	Clip Guide .75" long
4	460060	Guide Clip Spacer
5	460250	Clip Mounting Guide
6	807-1359	Low Head Pilot Screw, M5-.80 x 25mm
7	920691M	Low Head Cap Screw, M6-1.00 x 10mm
8	920693M	Low Head Cap Screw, M6-1.00 x 16mm

6200 Guide 3" (76mm) HS			
Length		End Guide	End Guide
2' (610mm)	Left Hand	460057-02400	N/A
	Right Hand	460057-02400	N/A
3' (914mm)	Left Hand	460057-03600	N/A
	Right Hand	460057-03600	N/A
4' (1219mm)	Left Hand	460057-04800	N/A
	Right Hand	460057-04800	N/A
5' (1524mm)	Left Hand	460057-06000	N/A
	Right Hand	460057-06000	N/A
6' (1829mm)	Left Hand	460057-07200	N/A
	Right Hand	460057-07200	N/A

7' (2134mm)	Left Hand	460057-08400	N/A
	Right Hand	460057-08400	N/A
8' (2438mm)	Left Hand	460057-09600	N/A
	Right Hand	460057-09600	N/A
9' (2743mm)	Left Hand	460057-10800	N/A
	Right Hand	460057-10800	N/A
10' (3048mm)	Left Hand	460057-12000	N/A
	Right Hand	460057-12000	N/A
11' (3353mm)	Left Hand	460057-13200	N/A
	Right Hand	460057-13200	N/A
12' (3658mm)	Left Hand	460057-14400	N/A
	Right Hand	460057-14400	N/A
13' (3962mm)	Left Hand	460257-08139	460257-07460
	Right Hand	460157-08139	460157-07460
14' (4267mm)	Left Hand	460257-09339	460257-07460
	Right Hand	460157-09339	460157-07460
15' (4572mm)	Left Hand	460257-10539	460257-07460
	Right Hand	460157-10539	460157-07460
16' (4877mm)	Left Hand	460257-11739	460257-07460
	Right Hand	460157-11739	460157-07460
17' (5182mm)	Left Hand	460257-12939	460257-07460
	Right Hand	460157-12939	460157-07460
18' (5486mm)	Left Hand	460257-14139	460257-07460
	Right Hand	460157-14139	460157-07460

-05 1.5" (38mm) Bolt-On High Side Guides

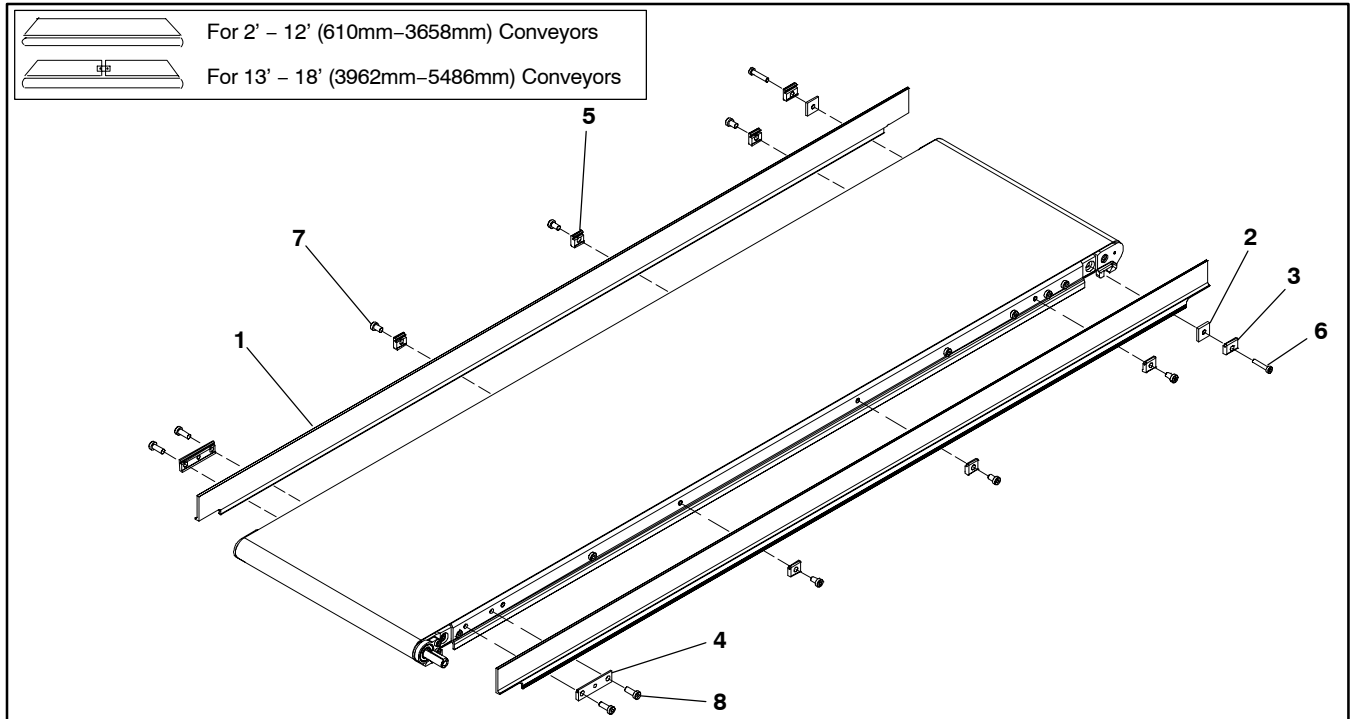

Item	Part Number	Description
1	See chart below	6200 Guide 1.5" (38mm) HS
2	460058	Spacer Guide Clip
3	460059	Clip Guide .75" long
4	460060	Guide Clip Spacer
5	460250	Clip Mounting Guide
6	807-1359	Low Head Pilot Screw, M5-.80 x 25mm
7	920691M	Low Head Cap Screw, M6-1.00 x 10mm
8	920693M	Low Head Cap Screw, M6-1.00 x 16mm

6200 Guide 1.5" (38mm) HS			
Length		End Guide	End Guide
2' (610mm)	Left Hand	460056-02400	N/A
	Right Hand	460056-02400	N/A
3' (914mm)	Left Hand	460056-03600	N/A
	Right Hand	460056-03600	N/A
4' (1219mm)	Left Hand	460056-04800	N/A
	Right Hand	460056-04800	N/A
5' (1524mm)	Left Hand	460056-06000	N/A
	Right Hand	460056-06000	N/A
6' (1829mm)	Left Hand	460056-07200	N/A
	Right Hand	460056-07200	N/A

7' (2134mm)	Left Hand	460056-08400	N/A
	Right Hand	460056-08400	N/A
8' (2438mm)	Left Hand	460056-09600	N/A
	Right Hand	460056-09600	N/A
9' (2743mm)	Left Hand	460056-10800	N/A
	Right Hand	460056-10800	N/A
10' (3048mm)	Left Hand	460056-12000	N/A
	Right Hand	460056-12000	N/A
11' (3353mm)	Left Hand	460056-13200	N/A
	Right Hand	460056-13200	N/A
12' (3658mm)	Left Hand	460056-14400	N/A
	Right Hand	460056-14400	N/A
13' (3962mm)	Left Hand	460256-08139	460256-07460
	Right Hand	460156-08139	460156-07460
14' (4267mm)	Left Hand	460256-09339	460256-07460
	Right Hand	460156-09339	460156-07460
15' (4572mm)	Left Hand	460256-10539	460256-07460
	Right Hand	460156-10539	460156-07460
16' (4877mm)	Left Hand	460256-11739	460256-07460
	Right Hand	460156-11739	460156-07460
17' (5182mm)	Left Hand	460256-12939	460256-07460
	Right Hand	460156-12939	460156-07460
18' (5486mm)	Left Hand	460256-14139	460256-07460
	Right Hand	460156-14139	460156-07460

Service Parts

-13 Fully Adjustable UHMW Guides

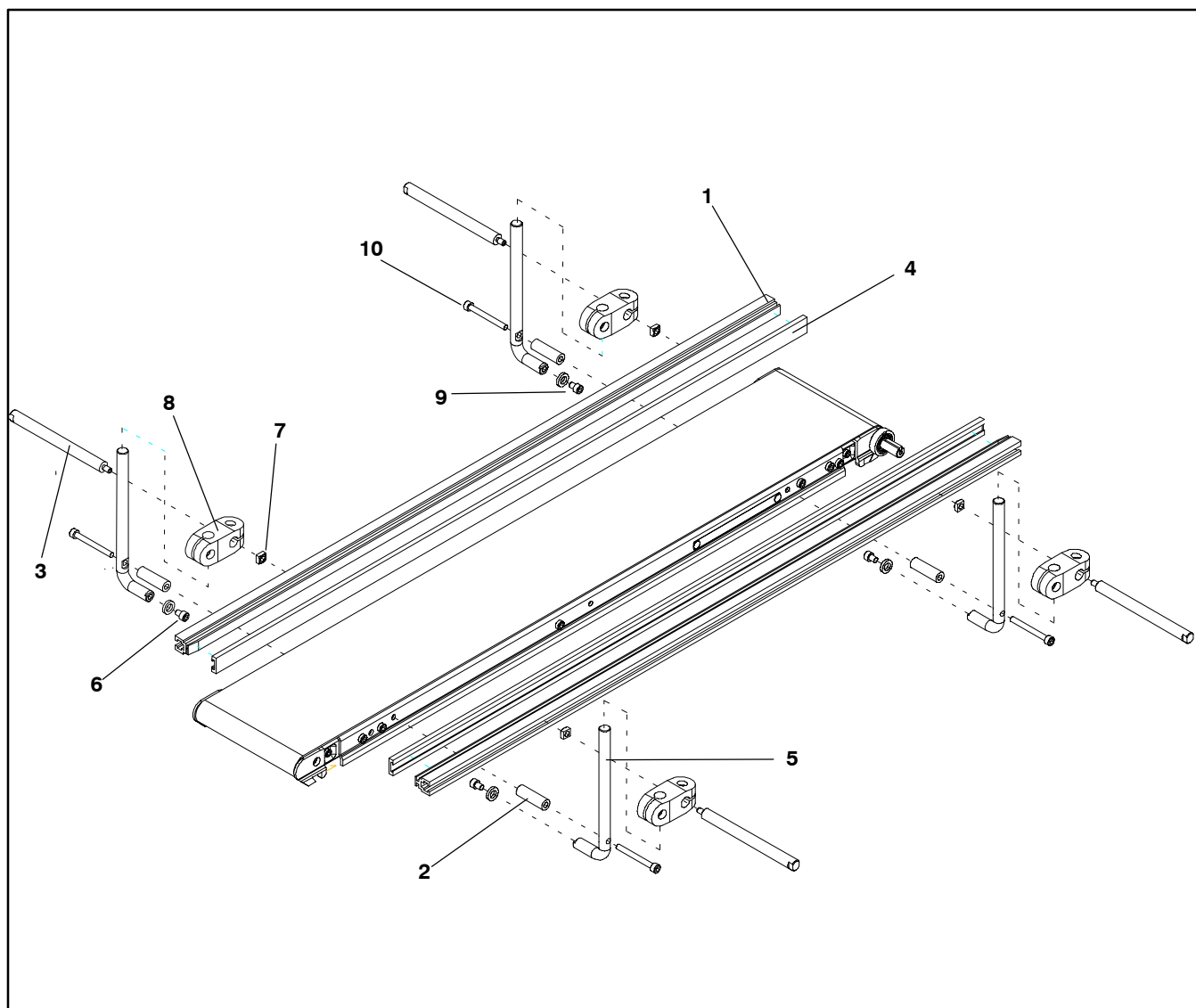

Item	Part Number	Description
1	202983	Guide Mounting Rail 2' (610mm)
	202984	Guide Mounting Rail 3' (914mm)
	202985	Guide Mounting Rail 4' (1219mm)
	202986	Guide Mounting Rail 5' (1524mm)
	202987	Guide Mounting Rail 6' (1829mm)
	202988	Guide Mounting Rail 7' (2134mm)
	202989	Guide Mounting Rail 8' (2438mm)
	202990	Guide Mounting Rail 9' (2743mm)
	202991	Guide Mounting Rail 10' (3053mm)
	202992	Guide Mounting Rail 11' (3353mm)
	202993	Guide Mounting Rail 12' (3658mm)

	202994	Guide Mounting Rail 13' (3962mm)
2	461351	Shaft Brace
3	202028M	Horizontal Shaft Mounting Guide
4	614068	Guide Extruded Flat (per foot)
5	461350M	Shaft Vertical Adj Guide
6	605279M	Hard Washer
7	674175MP	Square Nut M6-1.0 w/1/4-20
8	807-652	Cross Block
9	920608M	Socket Head Cap Screw M6-1.0 x 8mm
10	920655M	Socket Head Cap Screw M6-1.0 x 55mm

-20 Adjustable Width UHMW Guides

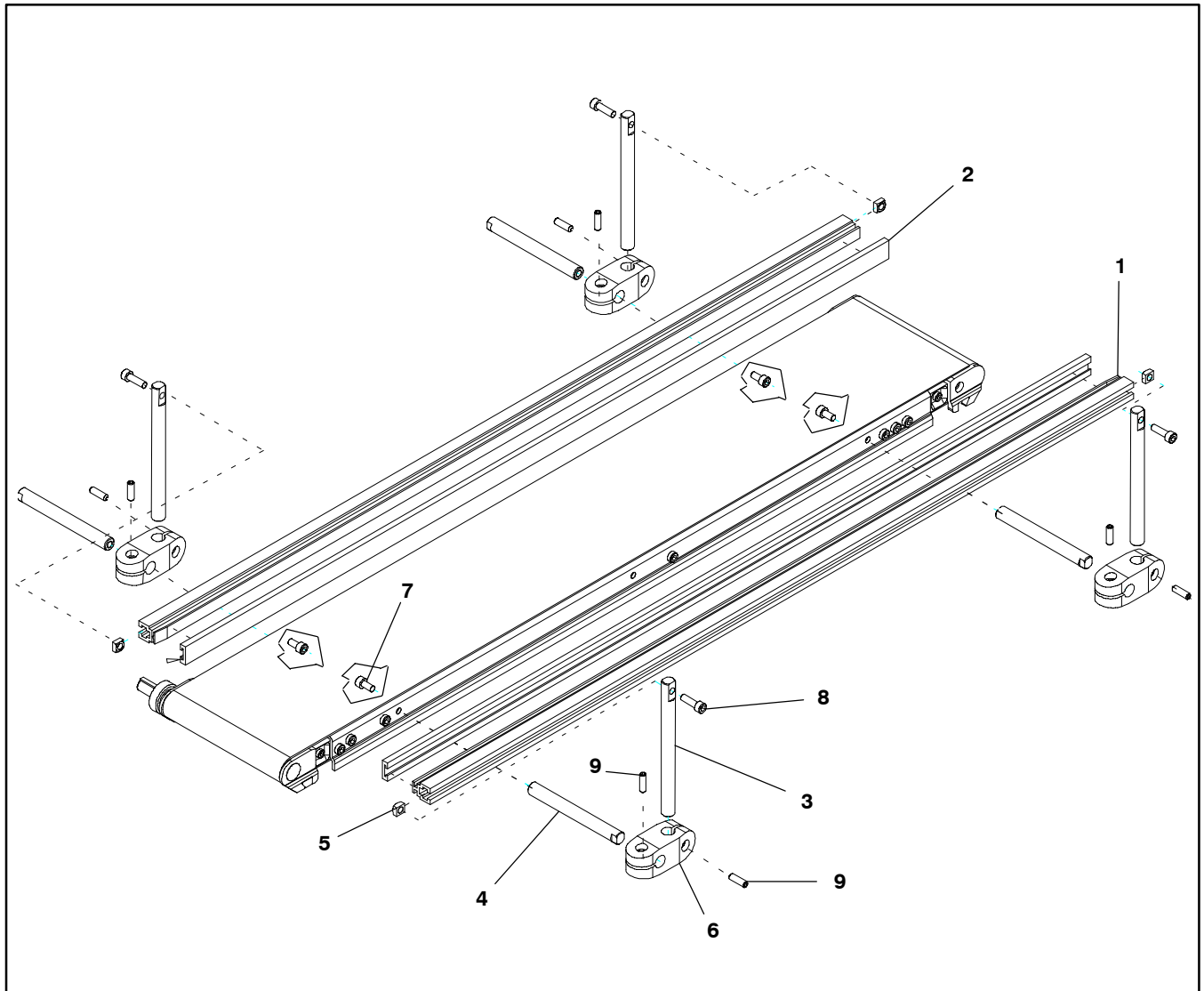

Item	Part Number	Description
1	202983	Guide Mounting Rail 2' (610mm)
	202984	Guide Mounting Rail 3' (914mm)
	202985	Guide Mounting Rail 4' (1219mm)
	202986	Guide Mounting Rail 5' (1524mm)
	202987	Guide Mounting Rail 6' (1829mm)
	202988	Guide Mounting Rail 7' (2134mm)
	202989	Guide Mounting Rail 8' (2438mm)
	202990	Guide Mounting Rail 9' (2743mm)
	202991	Guide Mounting Rail 10' (3048mm)
	202992	Guide Mounting Rail 11' (3353mm)
	202993	Guide Mounting Rail 12' (3658mm)

	202994	Guide Mounting Rail 13' (3962mm)
2	614068	Guide extruded flat (per foot)
3	462050M	Vertical Shaft Gullwing Guide
4	462052M	Horizontal Shaft Gullwing Guide
5	674175MP	Square Nut M6-1.0 w/1/4-20
6	807-652	Cross Block
7	920612M	Socket Head Cap Screw M6-1.0 x 12mm
8	920620M	Socket Head Cap Screw M6-1.0 x 20mm
9	970620M	Socket Head Set Screw M6-1.0 x 20mm

Service Parts

1" (25mm) Cleated Belt Conveyor Guides

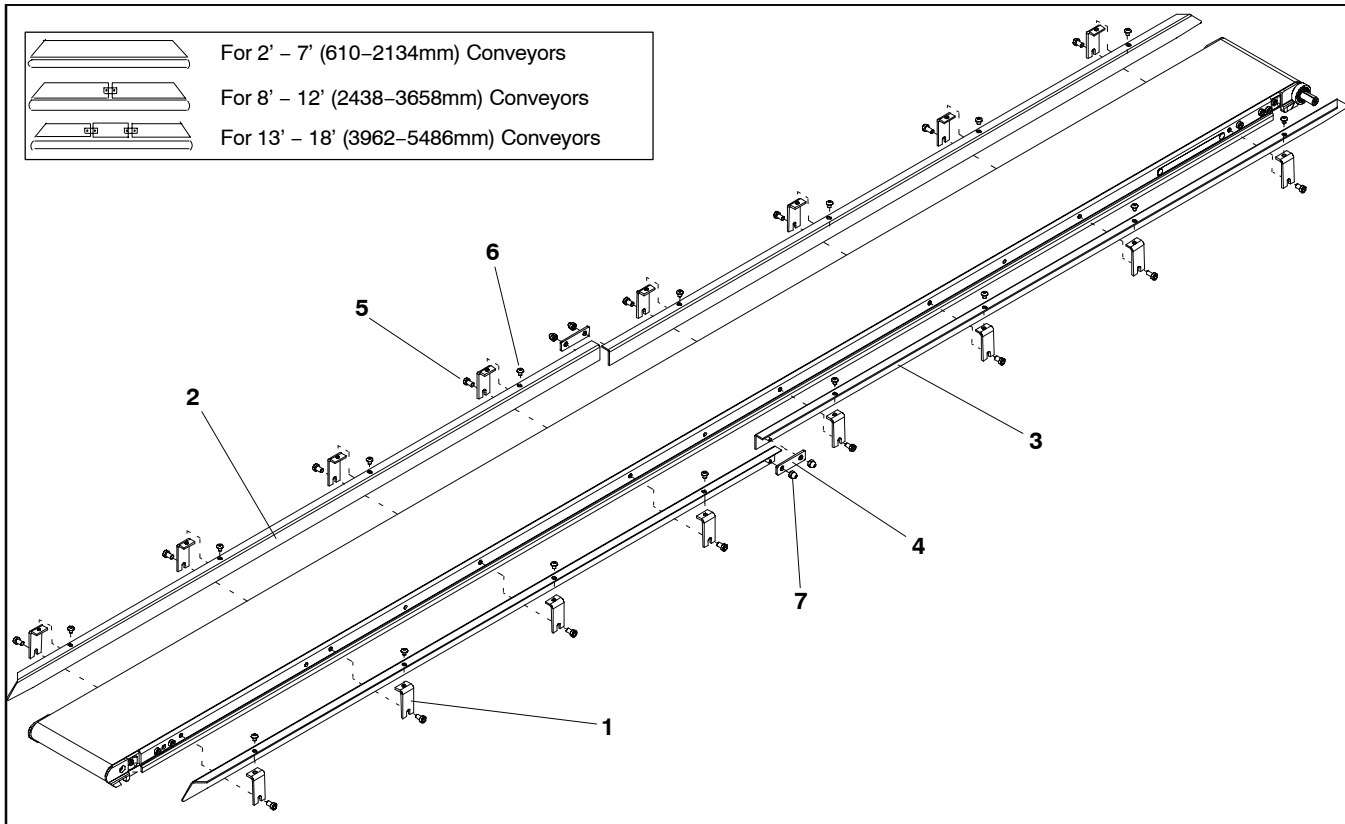

Item	Part Number	Description
1	462150MSS	1" Guide Mounting Bracket
2	See chart below	1" Guide RH
3	See chart below	1" Guide LH
4	450188SS	Guide Tie Plate
5	920691M	M6-1.0 x 10mm Low Head Screw
6	910506M	M5-0.8 x 6mm Button Head Screw
7	990508MSS	M5 Acorn Nut

Conveyor Length		End Guide	Center Guide	End Guide
2' (610mm)	Right Hand	462132SSP	N/A	N/A
	Left Hand	462132SSP	N/A	N/A
3' (914mm)	Right Hand	462133SSP	N/A	N/A
	Left Hand	462133SSP	N/A	N/A
4' (1219mm)	Right Hand	462134SSP	N/A	N/A
	Left Hand	462134SSP	N/A	N/A
5' (1524mm)	Right Hand	462135SSP	N/A	N/A
	Left Hand	462135SSP	N/A	N/A
6' (1829mm)	Right Hand	462136SSP	N/A	N/A
	Left Hand	462136SSP	N/A	N/A
7' (2134mm)	Right Hand	462137SSP	N/A	N/A
	Left Hand	462137SSP	N/A	N/A

8' (2438mm)	Right Hand	462144SSP	N/A	462154SSP
	Left Hand	462154SSP	N/A	462144SSP
9' (2743mm)	Right Hand	462144SSP	N/A	462154SSP
	Left Hand	462145SSP	N/A	462155SSP
10' (3048mm)	Right Hand	462155SSP	N/A	462145SSP
	Left Hand	462145SSP	N/A	462155SSP
11' (3353mm)	Right Hand	462146SSP	N/A	462156SSP
	Left Hand	462145SSP	N/A	462155SSP
12' (3658mm)	Right Hand	462146SSP	N/A	462156SSP
	Left Hand	462156SSP	N/A	462146SSP
13' (3962mm)	Right Hand	462146SSP	462163SSP	462156SSP
	Left Hand	462144SSP	462163SSP	462154SSP
14' (4267mm)	Right Hand	462146SSP	462163SSP	462156SSP
	Left Hand	462145SSP	462163SSP	462155SSP
15' (4572mm)	Right Hand	462146SSP	462163SSP	462156SSP
	Left Hand	462156SSP	462163SSP	462146SSP
16' (4877mm)	Right Hand	462146SSP	462166SSP	462156SSP
	Left Hand	462144SSP	462166SSP	462154SSP
17' (5182mm)	Right Hand	462146SSP	462166SSP	462156SSP
	Left Hand	462145SSP	462166SSP	462155SSP
18' (5486mm)	Right Hand	462146SSP	462166SSP	462156SSP
	Left Hand	462156SSP	462166SSP	462146SSP

2" (51mm) Cleated Belt Conveyor Guides

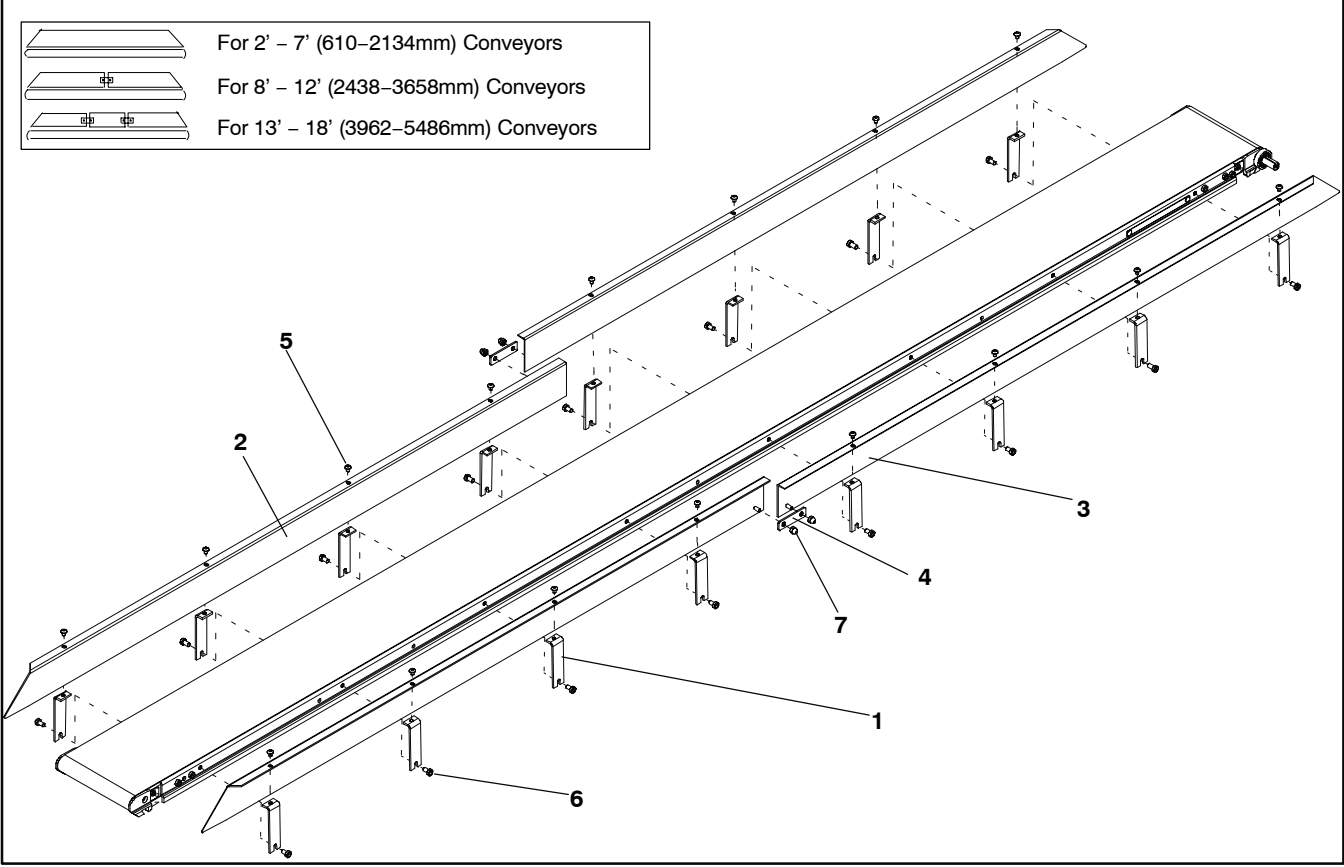

Item	Part Number	Description
1	462250MSS	2" Guide Mounting Bracket
2	See chart below	2" Guide RH
3	See chart below	2" Guide LH
4	450188SS	Guide Tie Plate
5	920691M	M6-1.0 x 10mm LowHead Screw
6	910506M	M5-0.8 x 6mm Button Head Screw
7	990508MSS	M5 Acorn Nut

Conveyor Length		End Guide	Center Guide	End Guide
2' (610mm)	Right Hand	462232SSP	N/A	N/A
	Left Hand	462232SSP	N/A	N/A
3' (914mm)	Right Hand	462233SSP	N/A	N/A
	Left Hand	462233SSP	N/A	N/A
4' (1219mm)	Right Hand	462234SSP	N/A	N/A
	Left Hand	462234SSP	N/A	N/A
5' (1524mm)	Right Hand	462235SSP	N/A	N/A
	Left Hand	462235SSP	N/A	N/A
6' (1829mm)	Right Hand	462236SSP	N/A	N/A
	Left Hand	462236SSP	N/A	N/A
7' (2134mm)	Right Hand	462237SSP	N/A	N/A
	Left Hand	462237SSP	N/A	N/A

8' (2438mm)	Right Hand	462244SSP	N/A	462254SSP
	Left Hand	462254SSP	N/A	462244SSP
9' (2743mm)	Right Hand	462244SSP	N/A	462254SSP
	Left Hand	462245SSP	N/A	462255SSP
10' (3048mm)	Right Hand	462255SSP	N/A	462245SSP
	Left Hand	462245SSP	N/A	462255SSP
11' (3353mm)	Right Hand	462246SSP	N/A	462256SSP
	Left Hand	462245SSP	N/A	462255SSP
12' (3658mm)	Right Hand	462246SSP	N/A	462256SSP
	Left Hand	462256SSP	N/A	462246SSP
13' (3962mm)	Right Hand	462246SSP	462263SSP	462256SSP
	Left Hand	462244SSP	462263SSP	462254SSP
14' (4267mm)	Right Hand	462246SSP	462263SSP	462256SSP
	Left Hand	462245SSP	462263SSP	462255SSP
15' (4572mm)	Right Hand	462246SSP	462263SSP	462256SSP
	Left Hand	462256SSP	462263SSP	462246SSP
16' (4877mm)	Right Hand	462246SSP	462266SSP	462256SSP
	Left Hand	462244SSP	462266SSP	462254SSP
17' (5182mm)	Right Hand	462246SSP	462266SSP	462256SSP
	Left Hand	462245SSP	462266SSP	462255SSP
18' (5486mm)	Right Hand	462246SSP	462266SSP	462256SSP
	Left Hand	462256SSP	462266SSP	462246SSP

Service Parts

2" (51mm) Through 6" (152mm) Flat Belt and Cleated Belt Return Roller

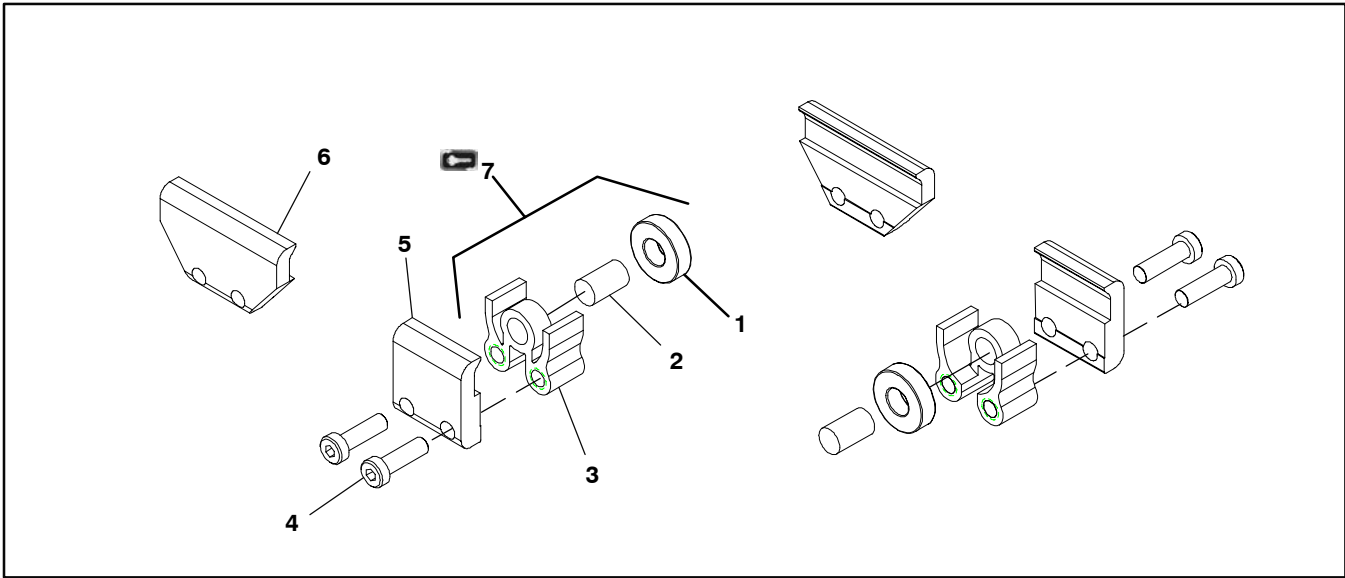

Item	Part Number	Description
1	802-027	Sealed Ball Bearing
2	913-103	Dowel Pin
3	450598	Return Roller Guard

4	920694M	Low-Head Cap Screw M6-1.0 x 20mm
5	450599	Return Roller Clip Flat Belt
6	450597	Return Roller Clip Cleated Belt
7	240840	Roller Assy.

8" (203mm) Through 18" (457mm) Flat Belt Return Roller

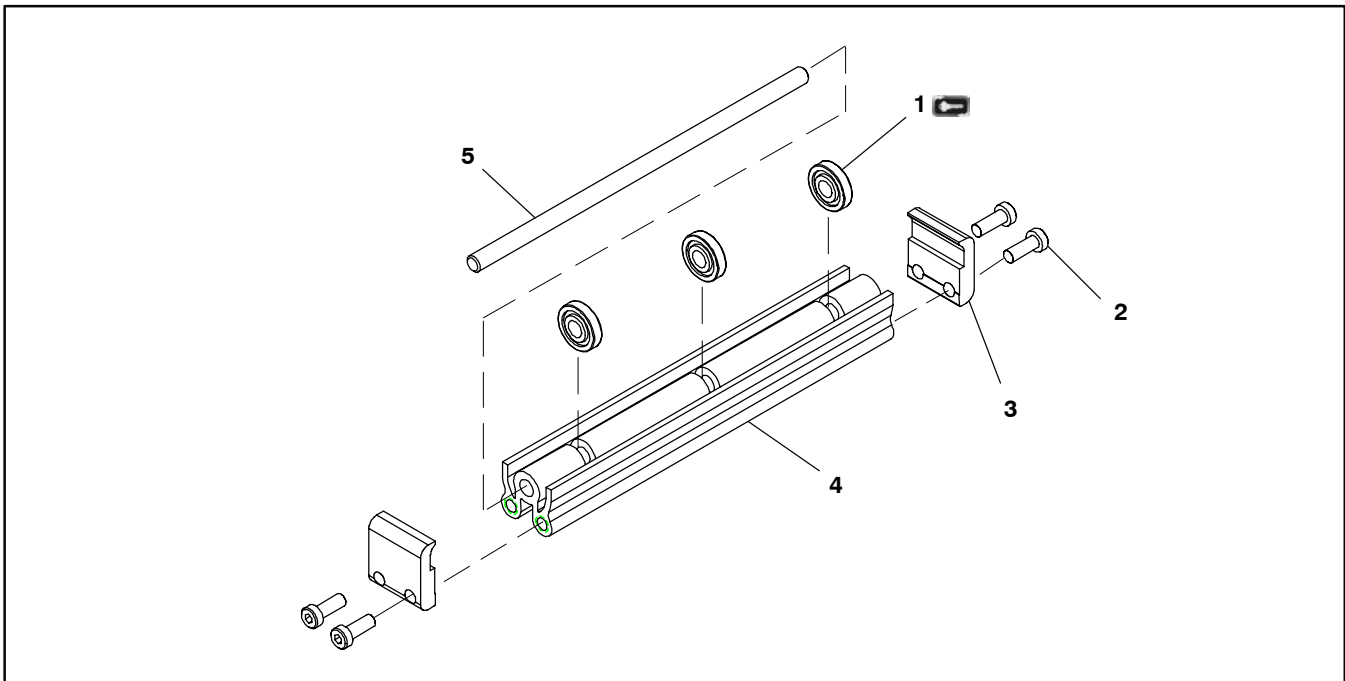

Item	Part Number	Description
1	240826	Return Roller
2	920693M	Low-Head Cap Screw M6-1.0 x 16mm
3	450599	Return Roller Clip Flat Belt

4	4511WW	Return Roller Guard
5	2410WW	Return Roller Rod
WW = Conveyor width ref.: 08, 10, 12, 18		

Conveyor Mounting Brackets

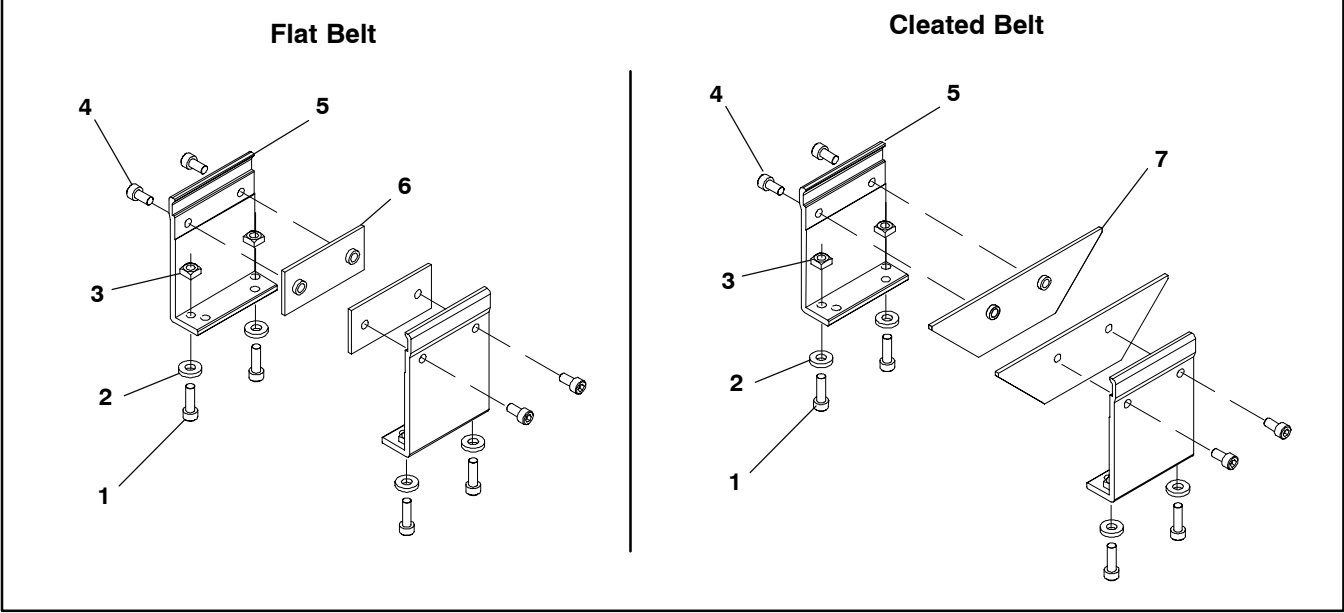

Item	Part Number	Description
1	920620M	Socket Head Cap Screw M6-1.0 x 20mm
2	605279P	Hard Washer
3	807-920	Square Nut M6-1.0

4	920612M	Socket Head Cap Screw M6-1.0 x 12mm
5	456031	Stand/Conveyor Mounting Bracket
6	450588	Mount Plate - Flat Belt
7	450586	Mount Plate - Cleated Belt

Configuring Conveyor Belt Part Number

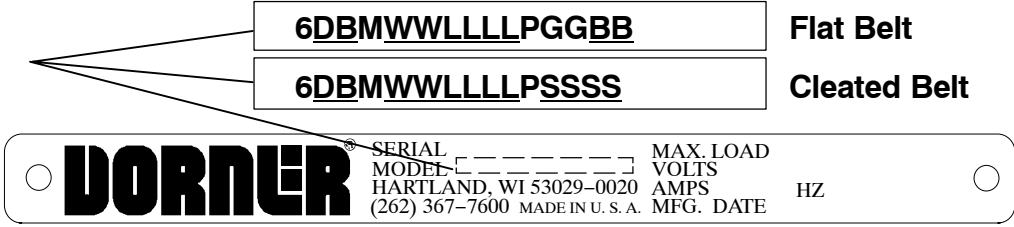
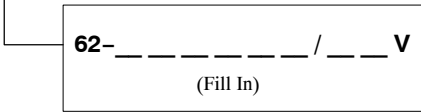

Figure 58

Flat Belt

Refer to your serial and model number plate (Figure 58). From the model number, determine conveyor width (WW), length (LLLL), and belt type (BB). Use data to configure belt part number as indicated below.

6D-WWLLLL/BBV



Cleated Belt

Refer to your serial and model number plate (Figure 58). From the model number, determine conveyor type (D), width (WW), length (LLLL), belt cleat type (B) and cleat spacing (SSSS). Use data to configure belt part number as indicated below.

6D-WWLLLLBSSSSV

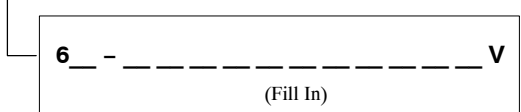

Return Policy

No returns will be accepted without prior written factory authorization. When calling for authorization, please have the following information ready for the Dorner Factory representative or your local distributor:

1. Name and address of customer.
2. Item(s) being returned.
3. Reason for return.
4. Customer's original order number used when ordering the item(s).
5. Dorner or distributor invoice number.

A representative will discuss action to be taken on the Returned items and provide a Returned Goods Authorization Number to reference.

There will be a 15% restocking charge on all new items returned for credit where Dorner was not at fault. These will not be accepted after 60 days from original invoice date. The restocking charge covers inspection, cleaning, disassembly, and reissuing to inventory.

If a replacement is needed prior to evaluation of returned item, a purchase order must be issued. Credit (if any) is issued only after return and evaluation is complete.

Dorner has representatives throughout the world. Feel free to contact Dorner for the name of your local representative. Our technical sales and service staff will gladly help with your questions on Dorner products.

For a copy of Dorner's Limited Warranty, contact factory, distributor, service center or visit our website @ www.dorner.com

**For replacement parts, contact an authorized
Dorner Service Center or the factory.**

DORNER[®]

Dorner Mfg. Corp. reserves the right to change or discontinue products without notice. All products and services are covered in accordance with our standard warranty. All rights reserved. ©Dorner Mfg. Corp. 2000

DORNER MFG. CORP.

975 Cottonwood Drive, PO Box 20
Hartland, WI 53029-0020 USA

USA

TEL 1-800-397-8664 (USA)

FAX 1-800-369-2440 (USA)

Internet: www.dorner.com

Outside the USA:

TEL 1-262-367-7600

FAX 1-262-367-5827