

7300 Series Sanitary End Drive Conveyors



Table of Contents

Warnings – General Safety	2	A – Belt Installation for Conveyor Without Gearmotor Mounting Package or Stands	11
Introduction	2	B – Belt Installation for Conveyor With Stands and/or Gearmotor Mounting Package	12
Product Description	3	Conveyor Belt Tensioning	13
Specifications	3	Pulley Removal	13
Installation	5	A – Drive Pulley Removal	13
Required Tools	5	B – Idler Pulley Removal	14
Recommended Installation Sequence	5	Bearing Replacement for Drive or Idler Pulley	16
Conveyors Up to 12 ft (3658 mm)	5	Bearing Removal	16
Conveyors Longer Than 12 ft (3658 mm)	5	Bearing Installation	16
Attaching Conveyor to Stands or Mounting Brackets ...	6	Pulley Installation	16
Return Rollers	7	A – Drive Pulley Installation	14
2" (51 mm) Through 6" (152 mm) Wide Flat Belt and All Cleated Belt Conveyors	7	B – Idler Pulley Installation	14
8" (203 mm) Through 18" (457 mm) Wide Flat Belt Conveyors	7	Service Parts	18
Preventative Maintenance & Adjustment	9	Drive End Components	18
Required Tools	8	Tension End Components	19
Checklist	8	Conveyor Frame and Extensions	20
Lubrication	8	–21 1" (25mm) Sanitary Bolt-On High Sides	21
Conveyor Bearings	8	–22 2" (51mm) Sanitary Bolt-On High Sides	22
Return Rollers	8	–23 Sanitary Fully Adjustable UHMW Guides	23
Maintaining Conveyor Belt	8	–24 Sanitary Adjustable Width UHMW Guides	24
Troubleshooting	8	Sanitary 2" (51 mm) Through 6" (152 mm) Wide Flat Belt and Cleated Belt Return Roller	25
Cleaning	9	Sanitary 8" (203 mm) Through 18" (457 mm) Wide Flat Belt Return Roller	25
Conveyor Belt Replacement	9	Conveyor Mounting Brackets	26
Conveyor Belt Replacement Sequence	9	Configuring Conveyor Belt Part Number	27
A – Belt Removal for Conveyor Without Gearmotor Mounting Package or Stands	9	Return Policy	28
B – Belt Removal for Conveyor With Stands and/or Gearmotor Mounting Package	10		

Warnings – General Safety

	WARNING	
<p>The safety alert symbol, black triangle with white exclamation, is used to alert you to potential personal injury hazards.</p>		

	WARNING
<p>Gearmotors may be HOT. DO NOT TOUCH Gearmotors.</p>	

	DANGER
<p>Climbing, sitting, walking or riding on conveyor will cause severe injury. KEEP OFF CONVEYORS.</p>	

	WARNING
<p>Dorner cannot control the physical installation and application of conveyors. Taking protective measures is the responsibility of the user.</p> <p>When conveyors are used in conjunction with other equipment or as part of a multiple conveyor system, CHECK FOR POTENTIAL PINCH POINTS and other mechanical hazards before system start-up.</p>	

	DANGER
<p>DO NOT OPERATE CONVEYORS IN AN EXPLOSIVE ENVIRONMENT.</p>	

	WARNING
<p>Exposed moving parts can cause severe injury. LOCK OUT POWER before removing guards or performing maintenance.</p>	

	WARNING
<p>Loosening stand height or angle adjustment screws may cause conveyor sections to drop down, causing severe injury. SUPPORT CONVEYOR SECTIONS PRIOR TO LOOSENING STAND HEIGHT OR ANGLE ADJUSTMENT SCREWS.</p>	

Introduction

IMPORTANT: Some illustrations may show guards removed. Do NOT operate equipment without guards.

Upon receipt of shipment:

- Compare shipment with packing slip. Contact factory regarding discrepancies.
- Inspect packages for shipping damage. Contact carrier regarding damage.
- Accessories may be shipped loose. See accessory instructions for installation.

Dorner's Limited Warranty applies.

Dorner 7300 Series conveyors are covered by Patent Nos. 5174435, 6109427 and corresponding patents and patent applications in other countries.

Dorner reserves the right to make changes at any time without notice or obligation.

Dorner has convenient, pre-configured kits of Key Service Parts for all conveyor products. These time saving kits are easy to order, designed for fast installation, and guarantee you will have what you need when you need it. Key Parts and Kits are marked in the Service Parts section of this manual with the Performance Parts Kits logo .

Product Description

Refer to Figure 1 for typical conveyor components.

Typical Components	
A	Conveyor
B	Gearmotor
C	Belt (Flat Belt Shown)
D	Mounting Plates
E	Return Roller
F	Support Stands
G	Motor Controller
H	Drive End
I	Tensioning End

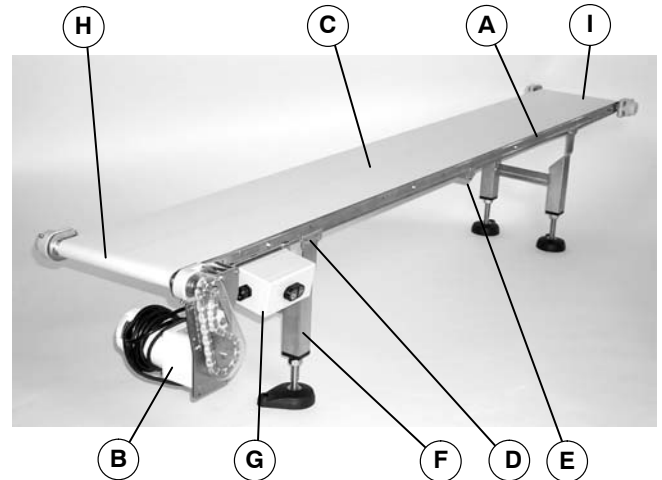
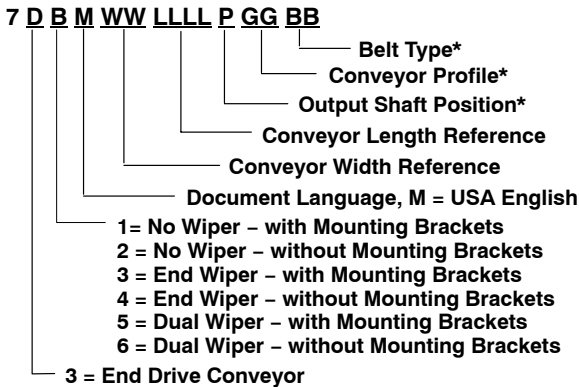

Figure 1

Specifications

Flat Belt 7300 Series Sanitary Conveyor



Cleated Belt 7300 Series Sanitary Conveyor

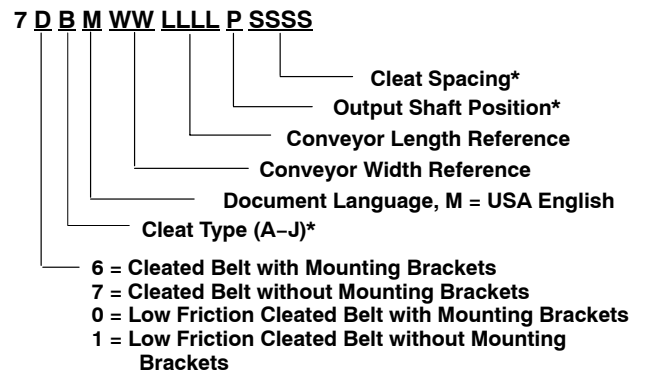

* See "Ordering and Specifications" Catalog for details.

Conveyor Supports:

Maximum Distances:

J = 18" (457 mm)**

K = 6 ft (1829 mm)***

L = 18" (457 mm)

** For Heavy Load Bottom Mount Package, mount support under gearmotor.

*** For conveyors longer than 12 ft (3658 mm), install support at frame joint.

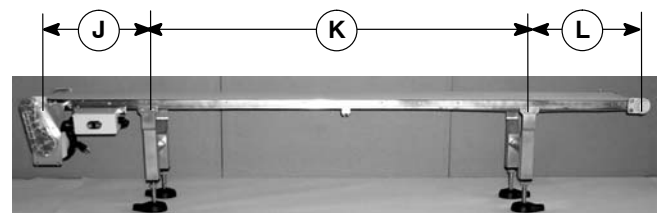

Figure 2

Specifications

Specifications:

Conveyor Width Reference (WW)	02	03	04	05	06	08	10	12	18
Conveyor Belt Width	1.75" (44 mm)	2.75" (70 mm)	3.75" (95 mm)	5" (127 mm)	6" (152 mm)	8" (203 mm)	10" (254 mm)	12" (305 mm)	18" (457 mm)
Maximum Conveyor Load* (See NOTE Below)	30 lb (14 kg)	35 lb (16 kg)	42 lb (19 kg)	50 lb (23 kg)	60 lb (27 kg)	70 lb (32 kg)	80 lb (36 kg)	80 lb (36 kg)	80 lb (36 kg)
Conveyor Start-up Torque*	4 in-lb (0.5 Nm)	5 in-lb (0.6 Nm)	6 in-lb (0.7 Nm)	7 in-lb (0.8 Nm)	8 in-lb (0.9 Nm)	10 in-lb (1.1 Nm)	12 in-lb (1.4 Nm)	14 in-lb (1.5 Nm)	15 in-lb (1.7 Nm)
Belt Travel	4.3" (109 mm) per revolution of pulley								
Maximum Belt Speed*	235 feet/minute (72 meters/minute)								
Belt Take-up	0.38" (10 mm) of stroke = 0.75" (19 mm) of belt take-up								

Conveyor Length Reference (LL)	02	03	04	05	06	07	08	09	10	11	12	13**	14**	15**	16**	17**	18**
Conveyor Length	2-ft (610 mm)	3-ft (914 mm)	4-ft (1219 mm)	5-ft (1524 mm)	6-ft (1829 mm)	7-ft (2134 mm)	8-ft (2438 mm)	9-ft (2743 mm)	10-ft (3048 mm)	11-ft (3353 mm)	12-ft (3658 mm)	13-ft (3962 mm)**	14-ft (4267 mm)**	15-ft (4572 mm)**	16-ft (4877 mm)**	17-ft (5182 mm)**	18-ft (5486 mm)**

* See "Ordering and Specifications" Catalog for details.

** Lengths available only in 6" (152 mm) & wider conveyors.

NOTE: Maximum conveyor loads are based on:

- Non-accumulating product
- Product moving towards gearmotor
- Conveyor being mounted horizontal
- Conveyor being located in a dry environment
- Conveyor with standard belt only

NOTE: 7300 Series sanitary conveyors are shipped with a “belt travel direction” sticker (M of Figure 3) installed. After drive is installed and tested, remove sticker.

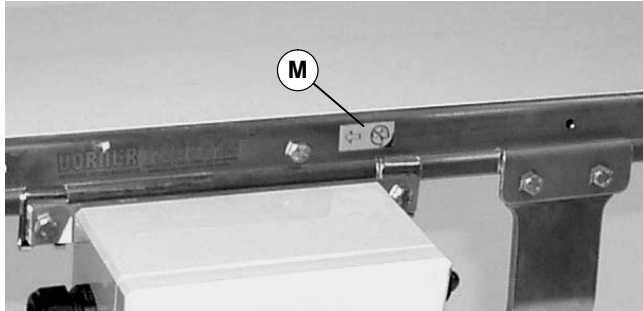

Figure 3

NOTE: Dorner recommends cleaning all the “food zones” prior to placing conveyor into service. Insure adequate access is provided for cleaning and servicing equipment so that the required level of hygiene can be maintained.

NOTE: Conveyor MUST be mounted straight, flat, and level within confines of conveyor. Use a level (N of Figure 4) during setup.

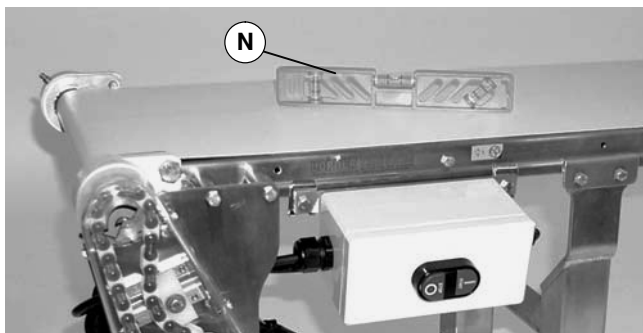

Figure 4

Required Tools

- 10 mm wrench (for hexagon head fasteners)
- Level
- Torque wrench

Recommended Installation Sequence

- Assemble conveyor (if required)
- Install stands (see accessory instructions)
- Attach stands/mounting brackets to conveyor (see page 6)

- Mount gearmotor mounting package (see accessory instructions)
- Attach return rollers (see page 7)
- Attach guides/accessories (see “Service Parts” section starting on page 18)

Conveyors Up to 12 ft (3658 mm)

No assembly is required. Install stands/mounting brackets and return rollers. Refer to “Attaching Conveyor to Stands or Mounting Brackets” on page 6 and “Return Rollers” on page 7.

Conveyors Longer Than 12 ft (3658 mm)

1. Typical components (Figure 5).

Frame Extension Components	
O	Conveyor frame extension
P	M6 x 10 mm Hex Head Cap Screws (12x)
Q	Connector Strips (2x)
R	Conveyor frame

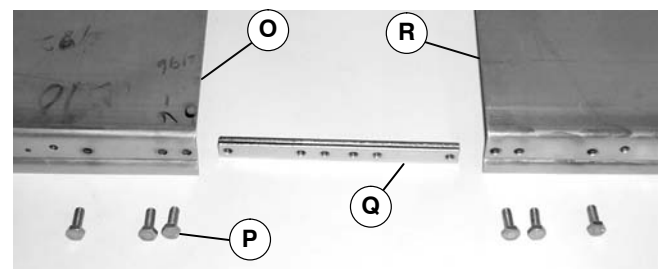

Figure 5

2. Compress tension end (Figure 6). Refer to steps 4 and 5 under the “Belt Removal for Conveyor Without Gearmotor Mounting Package or Stands” on page 9.



Figure 6

Installation

3. Install frame connecting bar (Q of Figure 7) on conveyor frame (R) with three screws (P). Do not tighten screws.

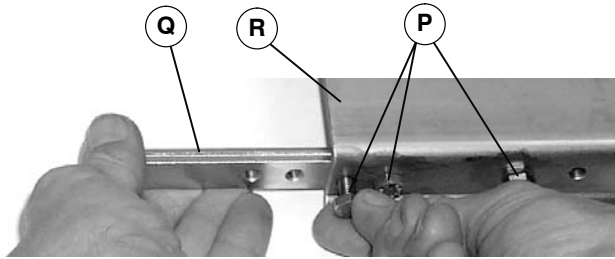

Figure 7

4. Repeat step 3 for other side of conveyor frame.
5. Install conveyor frame extension (O of Figure 8) on frame connecting bar (Q) with three screws (P). Install three screws (P) on opposite side. Tighten all screws to 92 in-lb (10.4 Nm).

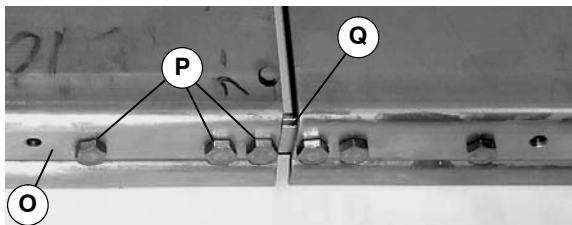

Figure 8

6. Install conveyor belt. Refer to steps 1 through 3 under “Belt Installation for Conveyor without Gear-motor Mounting Package or Stands” on page 13.
7. Tension conveyor belt. Refer to “Conveyor Belt Tensioning” on page 13.

Attaching Conveyor to Stands or Mounting Brackets

NOTE: Conveyor may be mounted using mounting brackets as shown in Figures 9 and 10 or directly to support stands. For direct support stand mounting, see stand manual.

1. Typical mounting bracket components (Figure 9).

Mounting Bracket Components (One Pair)

S	M6 x 10 mm Hex Head Cap Screw (4x)
T	M6 x 12 mm Hex Head Cap Screw (4x)
U	Stand/Conveyor Ear Mount Bracket (2x)
V	Clamp Plate, Flat Belt (2x)
	or
W	Clamp Plate, Cleated Belt (2x)

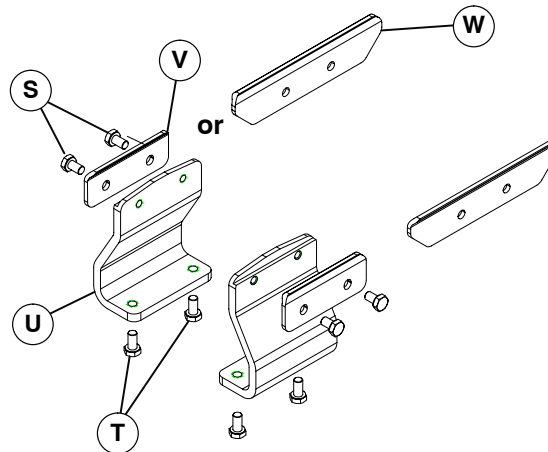

Figure 9

2. Attach clamp plate (V or W of Figure 9) to stand/conveyor ear mount bracket (U) with two screws (S). Do not tighten screws.
3. Attach stand/conveyor ear mount bracket (U of Figure 10) to bottom of conveyor (Z). Make sure notch (AA) on bracket straddles conveyor edge as shown. Snug-up two screws (S).

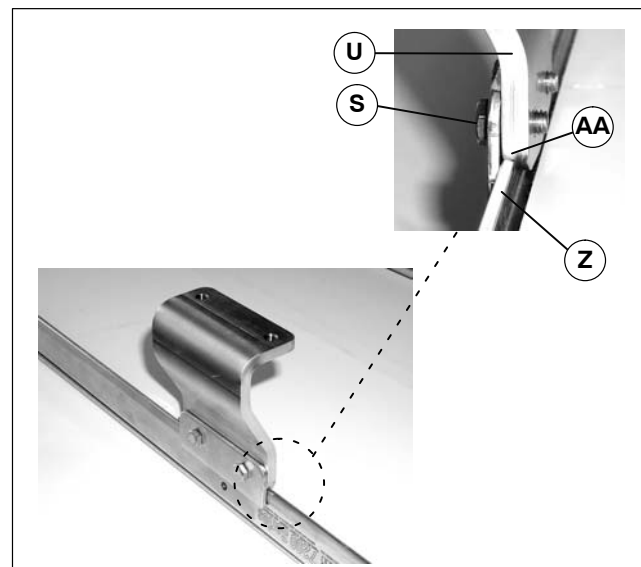

Figure 10

4. Repeat steps 2 and 3 for other mounting bracket(s). Tighten all screws (S) to 80 in-lb (9 Nm).

Return Rollers

2" (51 mm) Through 6" (152 mm) Wide Flat Belt and All Cleated Belt Conveyors

NOTE: No return rollers are required on conveyor lengths up to 7 ft (2134 mm). Use one pair of rollers centered between the tensioning and drive spindles on 8–15 ft (2438–4572 mm) conveyors. Use two pairs of rollers at one third distances between the tensioning and drive spindles on 16–18 ft (4877–5486 mm) conveyors.

1. Return roller components (Figure 11).

Return Roller Components	
AB	Mounting Block
AC	Clamp Plate
AD	Hex Head Cap Screw M6–1.0 x 12mm (2x)

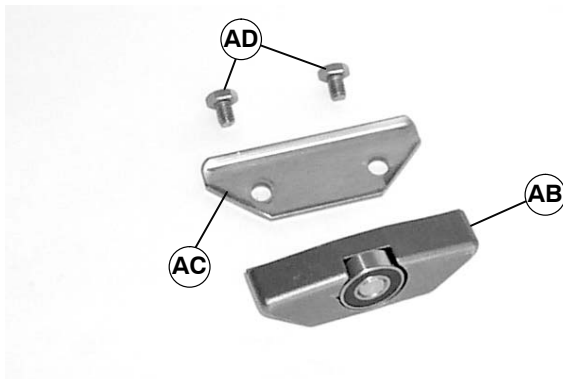

Figure 11

2. Loosely attach clamp plate (AC of Figure 12) on mounting block (AB) with two screws (AD). Do not tighten screws.

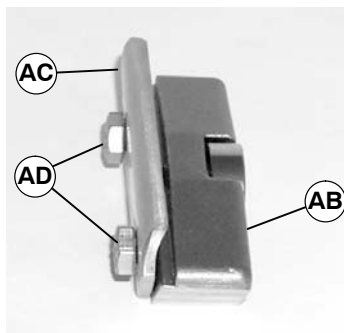

Figure 12

3. Attach return roller assembly (AE of Figure 13) on each side of conveyor (Z). Tighten screws (AD) to 80 in-lb (9 Nm).

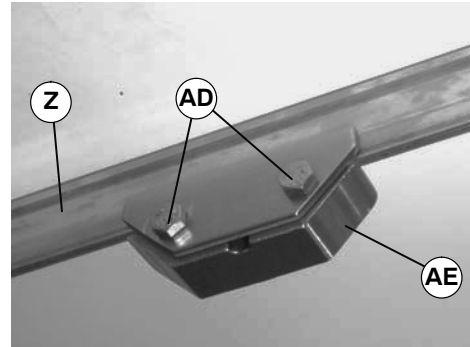

Figure 13

4. On 8–18 ft (2338–5486 mm) conveyor, repeat step 3 as necessary for other return rollers.

8" (203 mm) Through 18" (457 mm) Wide Flat Belt Conveyors

NOTE: No return rollers are required on conveyor lengths up to 7 ft (2134 mm). Use one roller centered between the idler and drive spindles on 8–15 ft (2438–4572 mm) conveyors. Use two rollers at one third distances between the idler and drive spindles on 16–18 ft (4877–5486 mm) conveyors.

1. Typical return roller components (Figure 14)

Return Roller Components	
AF	Return Roller and Guard Assembly
AG	Return Roller Clamp Plate (2x)
AH	Hex Head Cap Screw M6–1.0 x 12mm (4x)

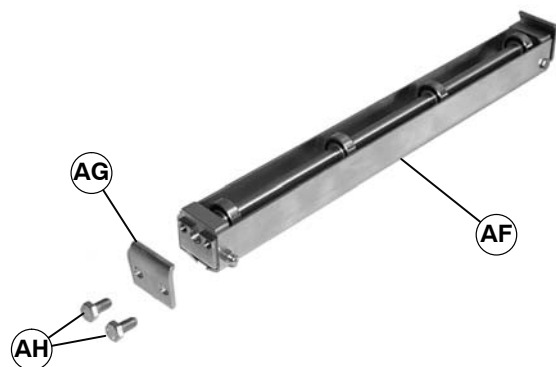

Figure 14

Installation

2. Loosely attach two clamp plates (AG of Figure 15) on roller and guard assembly (AF) with four screws (AH). Do not tighten screws.

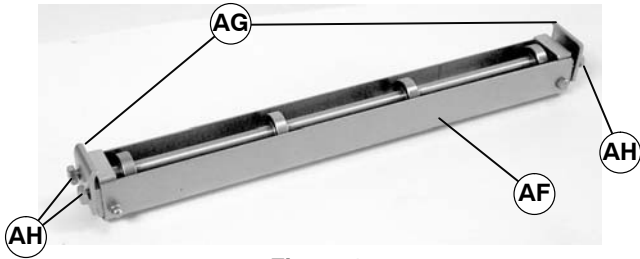

Figure 15

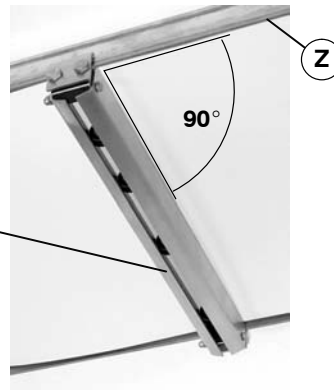

Figure 16

3. Attach return roller assembly (AI of Figure 16) on conveyor (Z). Make sure return roller assembly is perpendicular with conveyor frame as shown. Tighten screws (AH of Figure 15) to 80 in-lb (9 Nm).

4. On 16–18 ft (4877–5486 mm) conveyor, repeat steps 2 and 3 for other return roller.

Preventive Maintenance and Adjustment

Required Tools

- Wrenches: 8 mm, 10 mm, 17 mm, 3/8" (or an adjustable wrench)
- Hex key wrench: 3 mm

Checklist

- Keep service parts on hand (see “Service Parts” section for recommendations)
- Keep supply of belt cleaner (part # 625619)
- Clean entire conveyor and knurled pulley while disassembled
- Replace worn or damaged parts

Lubrication

Conveyor Bearings

No lubrication is required. Replace bearings if worn.

Return Rollers

No lubrication is required. Replace bearings if worn.

Maintaining Conveyor Belt

Troubleshooting

Inspect conveyor belt for:

- Surface cuts or wear
- Stalling or slipping
- Damage to V-guide

Surface cuts and wear indicate:

- Sharp or heavy parts impacting belt
- Jammed parts
- Improperly installed bottom wiper(s)
- Accumulated dirt in wiper(s)
- Foreign material inside the conveyor
- Improperly positioned accessories
- Bolt-on guiding is pinching belt

Stalling or slipping indicates:

- Excessive load on belt
- Conveyor belt or drive timing belt are not properly tensioned
- Worn knurl or impacted dirt on drive pulley
- Intermittent jamming or drive train problems

Damage to V-guide indicates:

- Twisted or damaged conveyor frame
- Dirt impacted on pulleys
- Excessive or improper side loading

NOTE: Visit www.dorner.com for complete list of troubleshooting solutions.

Preventive Maintenance and Adjustment

Cleaning

NOTE: Dorner recommends cleaning all the “food zones” prior to placing conveyor into service. Insure adequate access is provided for cleaning and servicing equipment so that the required level of hygiene can be maintained.

IMPORTANT: Do not use belt cleaners that contain alcohol, acetone, Methyl Ethyl Ketone (MEK) or other harsh chemicals.

Use Dorner Belt Cleaner (part # 625619). Mild soap and water may also be used. Do not soak the belt.

For /05 woven polyester and /06 black anti-static belts, use a bristled brush to improve cleaning.

Conveyor Belt Replacement



Conveyor Belt Replacement Sequence (see Table of Contents for page number)

- Remove old conveyor belt
 - A - Conveyor without Gearmotor Mounting Package or Stands
 - B - Conveyor with Stands and/or Gearmotor Mounting Package
- Install new conveyor belt
 - A - Conveyor without Gearmotor Mounting Package or Stands
 - B - Conveyor with Stands and/or Gearmotor Mounting Package
- Tension conveyor belt

A – Belt Removal for Conveyor Without Gearmotor Mounting Package or Stands

1. If installed, remove and retain two M5 hex head screws (AJ of Figure 17), bottom wiper (AK) and two sleeves (AL).

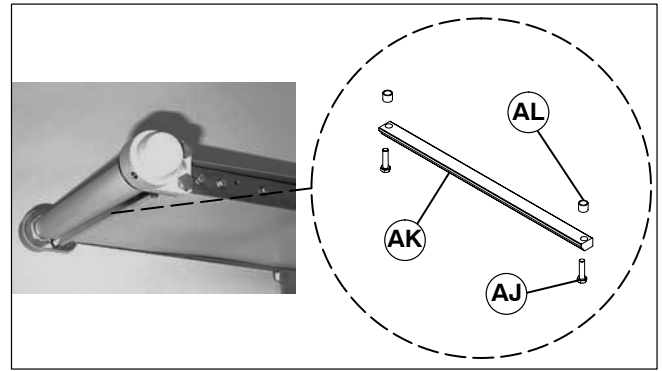

Figure 17

2. If installed, repeat step 1 for other wiper.
3. If conveyor is equipped with guiding and accessories or return rollers, remove and retain them as necessary.
4. Loosen four M6 hex head cap screws (AM of Figures 18 and 19).

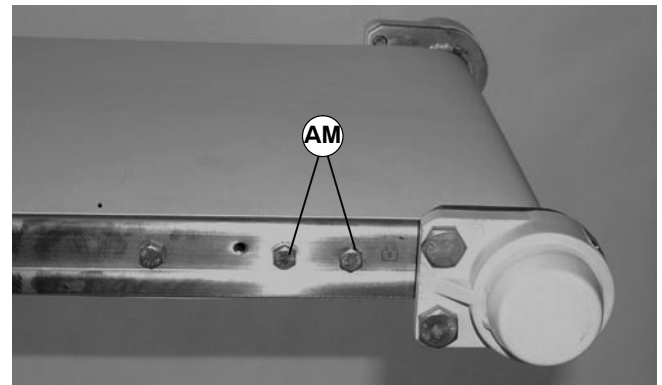

Figure 18

5. Retract idler spindle assembly (AN of Figure 19) by pushing in on it or by turning M6 hex head pinion screw (AO) clockwise.

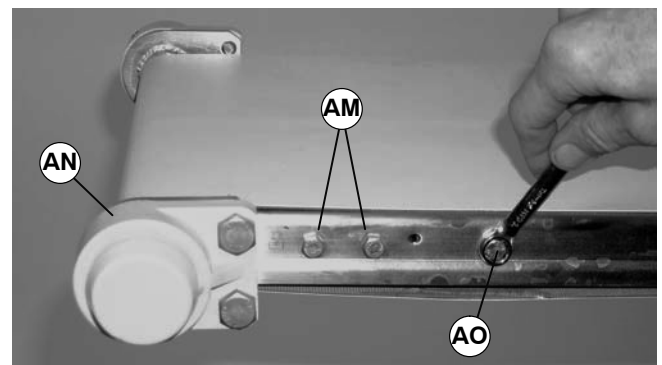

Figure 19

Preventive Maintenance and Adjustment

6. Remove bearing cover (AP of Figure 20) from drive end of conveyor.



Figure 20

7. Using a 3mm hex key wrench (AQ of Figure 21), loosen two set screws (AR) on bearing and head plate assembly (AS).

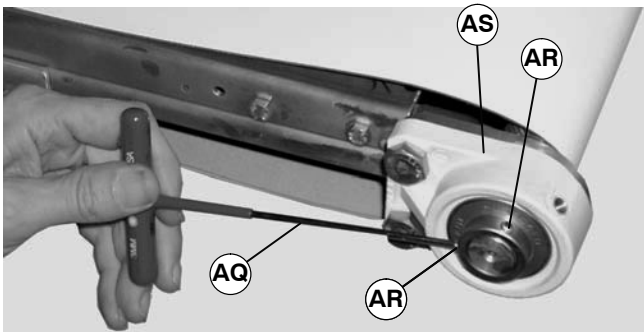

Figure 21

8. Remove three hex head screws (AT and AU of Figure 22) from bearing and head plate assembly (AS), cross support post (AV of Figure 23) and conveyor (Z).

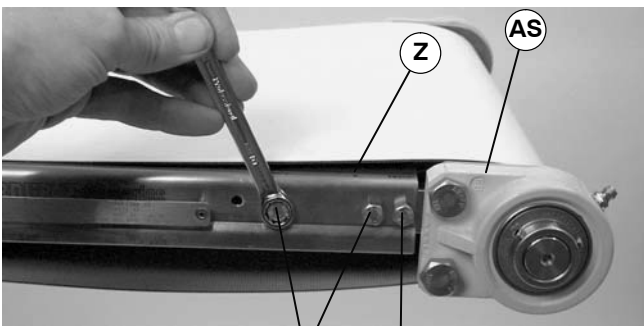

Figure 22

9. Rotate bearing and head plate assembly (AS of Figure 23) down and then off of cross support post (AV) and drive spindle (AW).

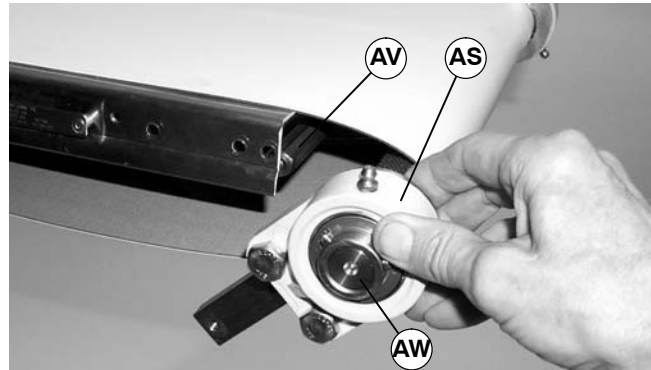

Figure 23

10. Remove conveyor belt (AX of Figure 24).



Figure 24

B – Belt Removal for Conveyor With Stands and/or Gearmotor Mounting Package

NOTE: For conveyor with a Heavy Load Bottom or Top Gearmotor Mounting Package, bracket (AY of Figure 25) must be removed.

- Remove two M6x30 mm hex head cap screws and spacers (AZ).
- Remove two M6x16 mm hex head cap screws (BA).
- Remove bracket (AY).

Preventive Maintenance and Adjustment

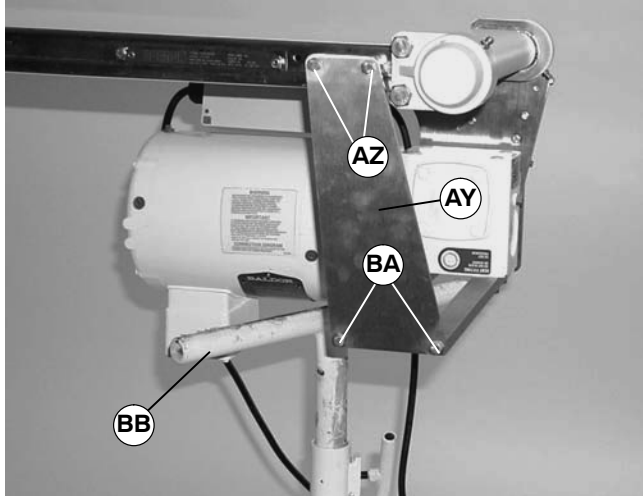

Figure 25

1. Perform steps 1 through 9 under “Belt Removal for Conveyor Without Gearmotor Mounting Package or Stands”.

	WARNING	
<p>The weight of the gearmotor is all on one end of the conveyor which could cause it to tip off the stands when the mounting clamp plates are loosened. Be sure to provide support (BB of Figures 25 and 26) underneath the gearmotor while changing the belt.</p>		

2. Place a temporary support (BB of Figures 25 and 26) under gearmotor mounting package.



Figure 26

3. Loosen two clamp plate screws (S of Figure 27) on side of conveyor opposite drive motor.

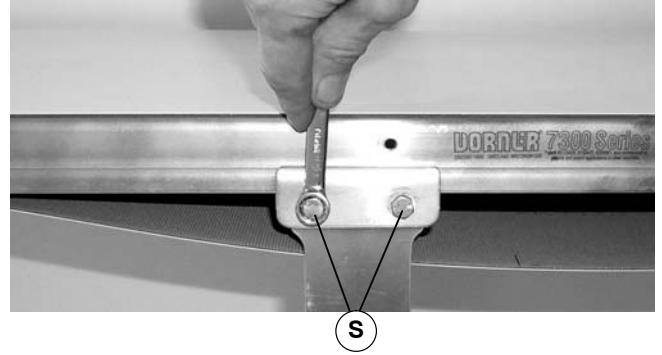

Figure 27

4. Repeat step 3 for remaining stand/conveyor ear mount brackets or stand assemblies on same side of conveyor.
5. Raise conveyor and remove conveyor belt (AX of Figure 28).



Figure 28

6. If a new belt will not be installed immediately, secure conveyor with stand/conveyor ear mount brackets or stand assemblies.

A – Belt Installation for Conveyor without Gearmotor Mounting Package or Stands

1. Orient conveyor belt so the splice leading fingers (BD of Figure 29) point in the direction of belt travel (BE).

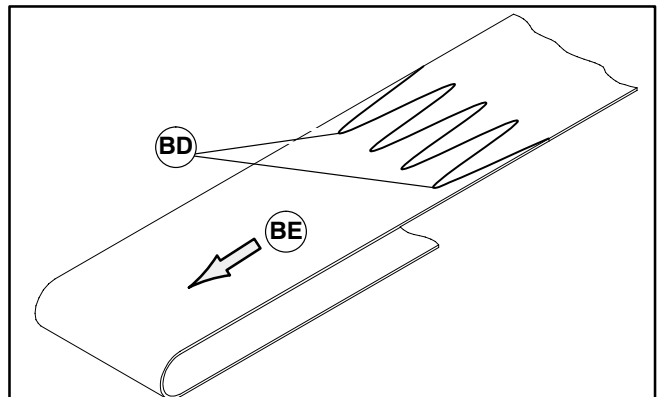

Figure 29

Preventive Maintenance and Adjustment

- Slide belt (AX of Figure 24) onto the conveyor frame assembly.
- Install bearing and head plate assembly (AS of Figure 30) onto drive spindle (AW).

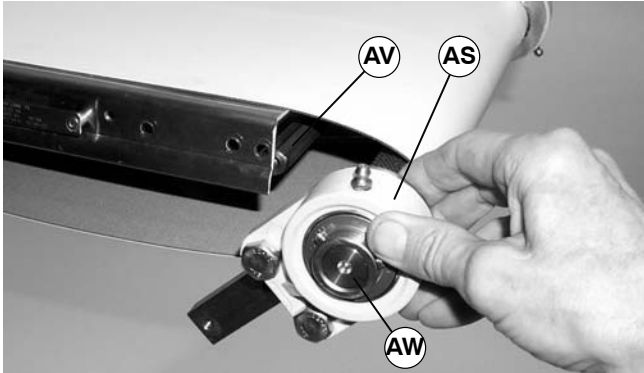

Figure 30

- Rotate bearing and head plate assembly (AS of Figure 31) up between inside of conveyor (Z) and cross support post (AV). Make sure cross support post engages slot (BF) in head plate.

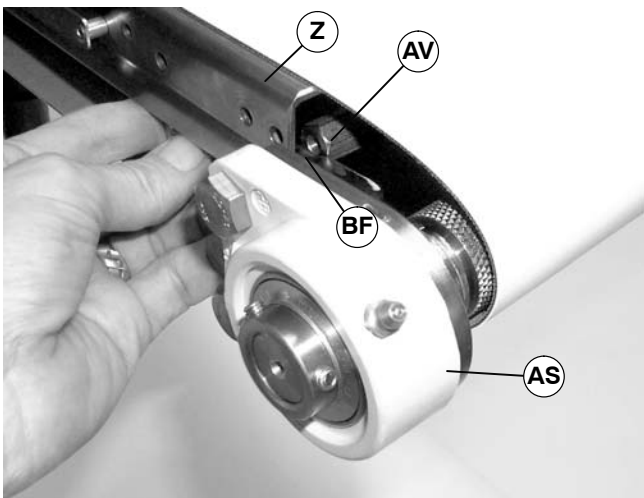

Figure 31

- Install three hex head screws (AT and AU of Figure 22) to secure bearing and head plate assembly (AS of Figure 31) to cross support post (AV) and conveyor (Z).
- Using a 3mm hex key wrench (AQ of Figure 21), tighten two set screws (AR) on bearing (AS).
- Install bearing cover (AP of Figure 20) on drive end of conveyor.
- If removed, install sleeves (AL of Figure 17), bottom wiper(s) (AK) and M5 hex head screws (AJ). Tighten screws to 33 in-lb (3.7 Nm).

- Tension belt. Refer to “Conveyor Belt Tensioning” on page 13.
- If removed, install return rollers, guiding and accessories.

B – Belt Installation for Conveyor with Gearmotor Mounting Package and/or Stands

IMPORTANT: On a flat belt conveyor, the wiper is installed on discharge end. Belt travel direction is identified by an arrow decal on the drive cover (BC of Figure 32).

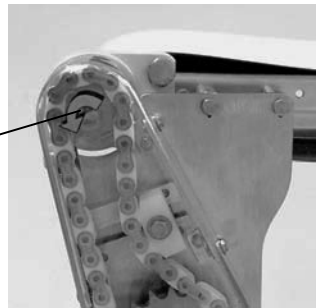

Figure 32

- Orient conveyor belt so that the splice leading fingers (BD of Figure 29) point in the direction of belt travel (BE) as identified by the label (BC of Figure 32).
- Slide belt (AX of Figure 28) onto conveyor frame assembly.
- Tighten two clamp plate screws (S of Figure 27)
- Repeat step 3 for remaining stand/conveyor ear mount brackets or stand assemblies.
- Install bearing and head plate assembly following steps 3 through 7 under “Belt Installation for Conveyor Without Gearmotor Mounting Package or Stands” on page 11.
- If removed, install sleeves (AL of Figure 17), bottom wiper(s) (AK) and M5 hex head screws (AJ). Tighten screws to 33 in-lb (3.7 Nm).
- For a conveyor with a Heavy Load Bottom or Top Mounting package, install bracket (AZ of Figure 25).
- Tension belt. Refer to “Conveyor Belt Tensioning” on page 13.
- If removed, install return rollers, guiding and accessories.

Preventive Maintenance and Adjustment

Conveyor Belt Tensioning



1. On tension end of the conveyor, loosen two M6 hex head cap screws (AM of Figure 33) on each side of conveyor.

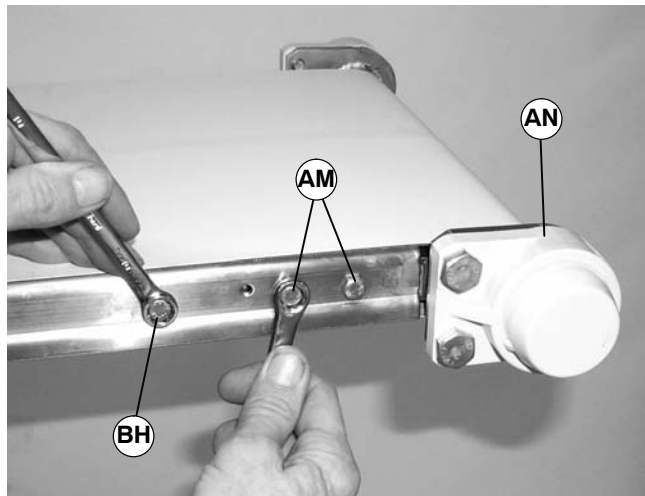

Figure 33

NOTE: Do not exceed a torque of 25 in-lb (2.8 Nm) for 2" to 12" (44 mm to 305 mm) wide conveyors or 40 in-lb (4.5 Nm) for an 18" (457 mm) wide conveyor on tensioning screw (BH). Over-tensioning the conveyor belt could cause excessive pulley bearing load and early failure.

2. Extend idler spindle assembly (AN) by turning M6 hex head screw (BH) clockwise to sufficiently tension belt to handle conveyor load.
3. Tighten four M6 hex head screws (AM) to 40 in-lb (4.5 Nm) to secure idler spindle assembly (AN).

NOTE: If the maximum take-up stroke is achieved, replace the conveyor belt.

Pulley Removal

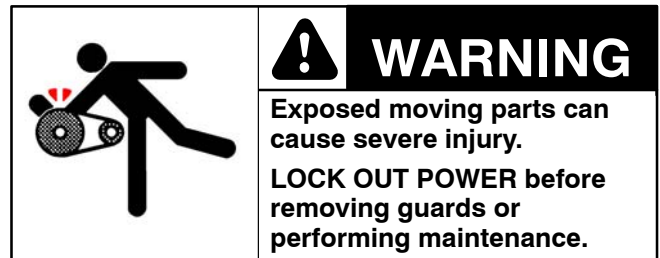

Remove conveyor belt to access pulley(s). See "Conveyor Belt Replacement" on page 9. Remove the desired pulley following instructions:

- A – Drive Pulley Removal
- B – Idler Pulley Removal

A – Drive Pulley Removal

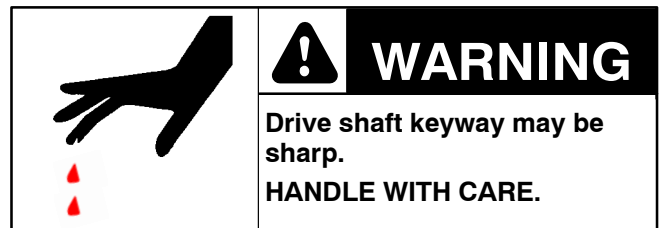

1. Remove the gearmotor mounting package. See accessory instructions.

NOTE: Two screws (BI of Figure 34) were removed in step 1.

If conveyor is in the upright position, cross support post (AV) will not be secure and may drop when screws (BJ of Figure 34 and AU of Figure 35) are removed.

2. Remove screw (BJ) from conveyor (Z) and cross support post (AV).

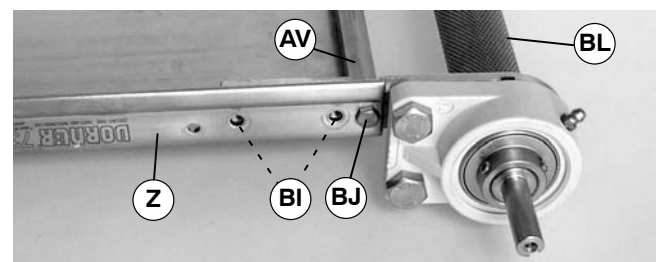

Figure 34

3. Remove screw (AU of Figure 35) and cross support post (AV) from conveyor (Z) and drive spindle assembly (BL).

Preventive Maintenance and Adjustment

NOTE: For a conveyor with a Heavy Load Bottom or Top Gearmotor Mounting Package, the two screws (BK of Figure 35) were removed in step 1.

If conveyor is in the upright position, drive spindle assembly (BL of Figure 35) will not be secure and may drop when screws (AU, BJ and BK of Figures 34 and 35) are removed.

4. Remove two screws (BK of Figure 35) and drive spindle assembly (BL) from conveyor (Z).

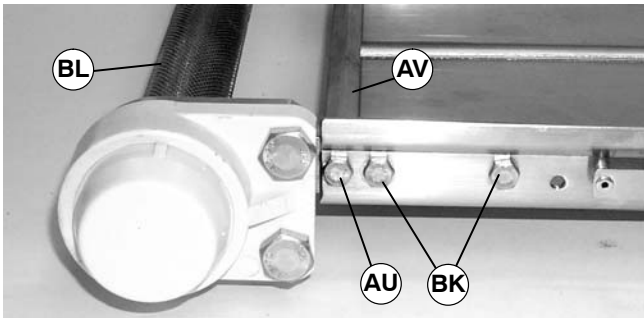

Figure 35

5. On closed end of drive spindle assembly (BL of Figure 36), use a screwdriver to pry off bearing cover (AP).

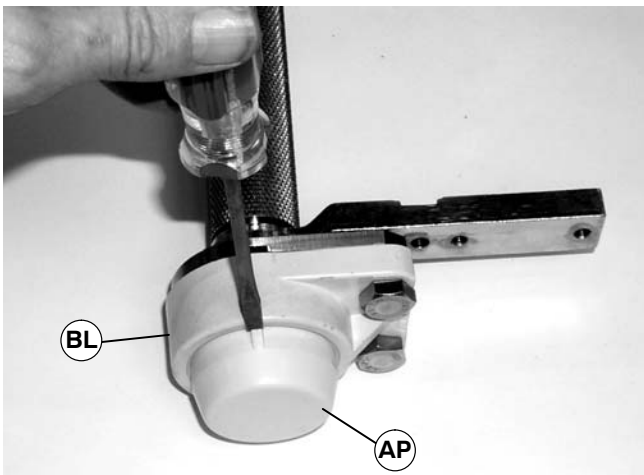

Figure 36

6. Using a 3mm hex key wrench (AQ of Figure 37), loosen two set screws (AR) on bearing and head plate assembly (AS).

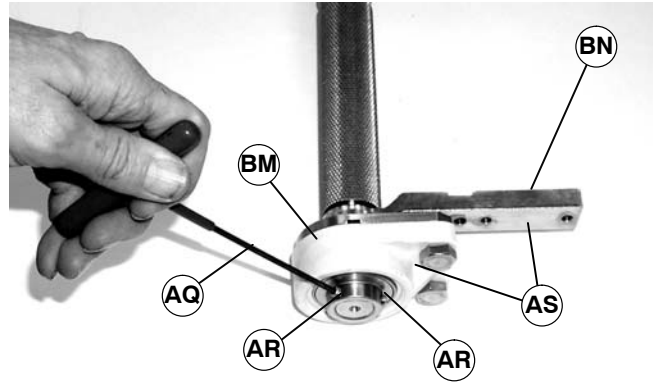

Figure 37

7. Remove bearing and head plate assembly (AS of Figure 38) from drive spindle (AW).

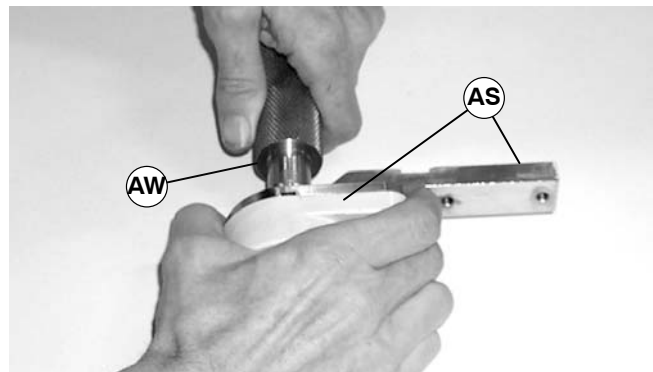

Figure 38

8. Repeat steps 6 and 7 for opposite side of drive spindle.

NOTE: If bearings (BM of Figure 37) require removal from head plates (BN), see "Bearing Removal" on page 16.

B – Idler Pulley Removal

1. While holding hex pinion (BO of Figure 39) with a 3/8" open-end wrench, loosen M6 hex head cap screw (AO).

Preventive Maintenance and Adjustment

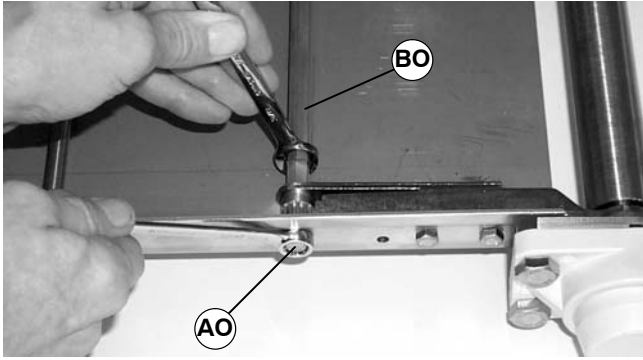

Figure 39

- Remove M6 hex head cap screw (AO of Figure 40) and sleeve (BP) from conveyor (Z) and hex pinion (BO).

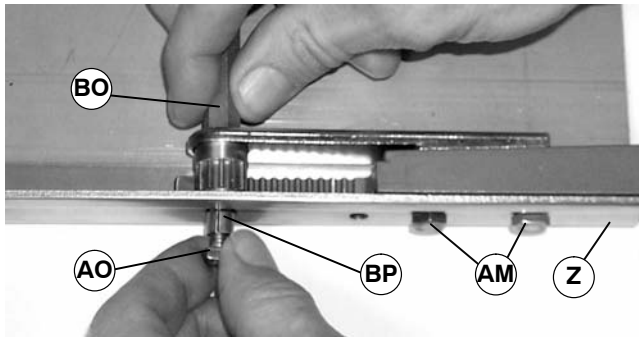

Figure 40

- Repeat steps 1 and 2 for screw (BH of Figure 41) on opposite side of conveyor.
- Remove two M6 hex head cap screws (AM) from each side of conveyor.
- Remove two pinion ends (BQ), clamp blocks (BR), hex pinion (BO), two spacers (BS) and tail assembly (AN) from conveyor (Z).

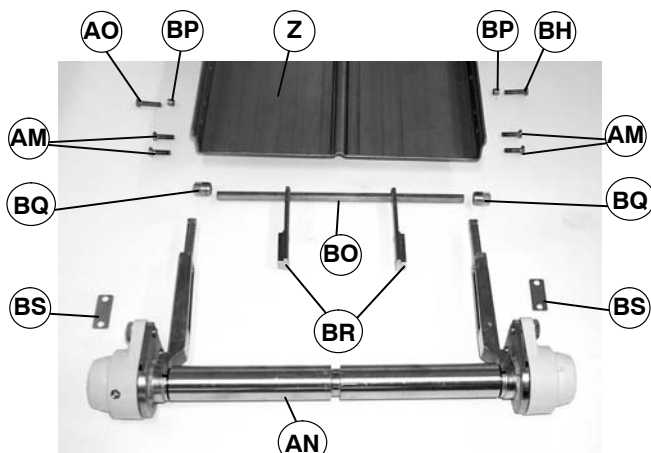

Figure 41

- Use a screwdriver to remove bearing cover (BT of Figure 42) from tail assembly (AN).

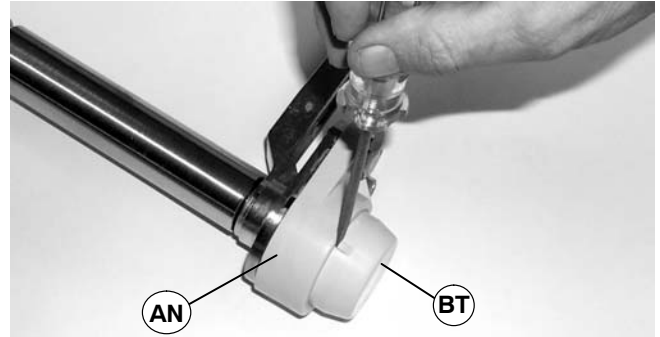

Figure 42

- Using a 3mm hex key wrench (AQ of Figure 43), loosen two set screws (BU) on bearing and head plate assembly (BV).

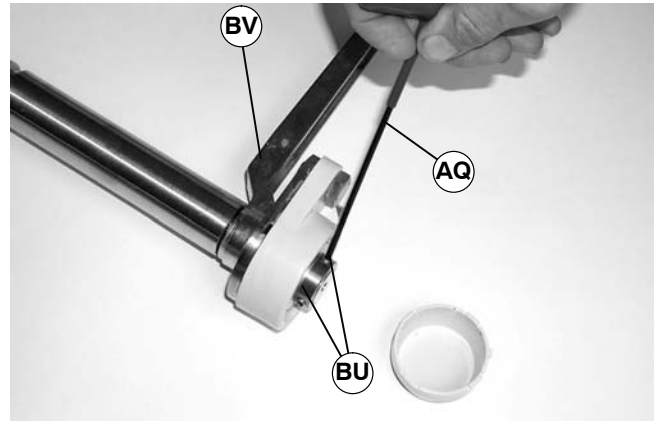

Figure 43

- Remove bearing and head plate assembly (BV of Figure 44) from idler spindle (BW).

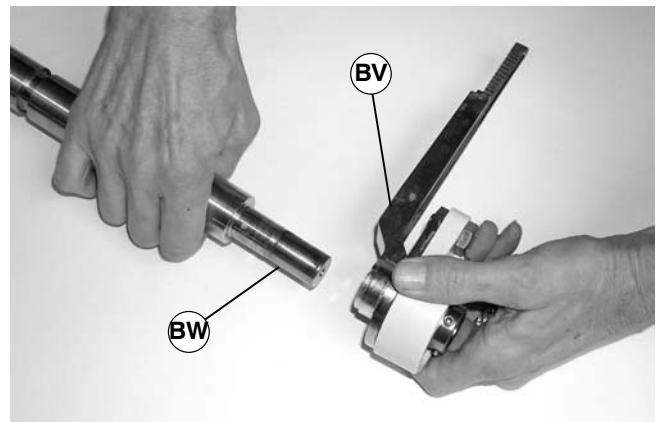

Figure 44

- Repeat steps 6, 7 and 8 for opposite side of idler spindle.

Preventive Maintenance and Adjustment

Bearing Replacement for Drive or Idler Pulley

Bearing Removal

1. Using a 17 mm wrench, remove two hex head screws (BX of Figure 45) from bearing (BY) and head plate (BZ).

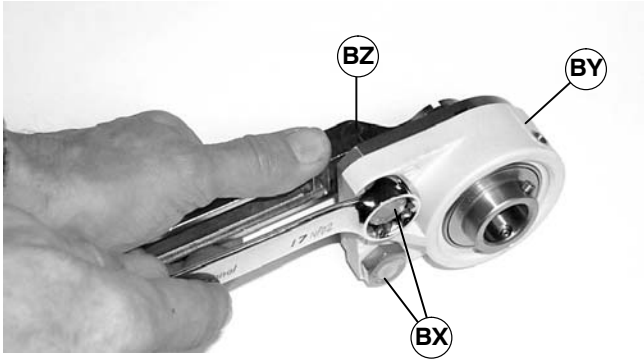

Figure 45

Bearing Installation

1. Install bearing (BY of Figure 45) on head plate (BZ) with two hex head screws (BX). Tighten screws to 36 ft-lb (49 Nm).

Pulley Installation

A – Drive Pulley Installation

1. Make sure bearing surfaces on drive spindle are free of nicks and burrs. Slide bearing and head plate assembly (AS of Figure 38) on drive spindle (AW).
2. Repeat step 1 for opposite side of drive spindle.
3. Position drive spindle assembly (BL of Figure 35) on conveyor (Z) and loosely secure with two screws (BK).
4. Install cross support post (AV of Figure 35) and secure with two screws (BJ of Figure 34 and AU of Figure 35). Tighten screws to 33 in-lb (3.7 Nm).

IMPORTANT: Before tightening set screws on bearing and head plate assemblies, make sure that center of groove (CA of Figure 46) on spindle (AW) is in line with center of groove (CB) on conveyor (Z).

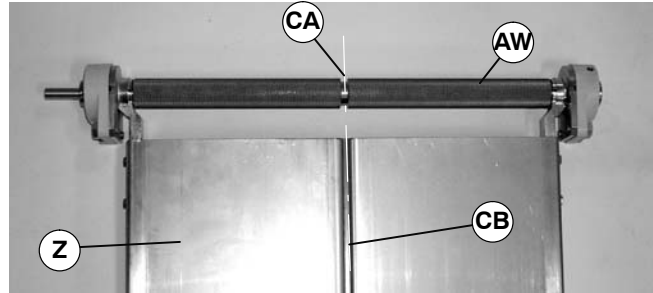

Figure 46

5. Make sure center of groove (CA of Figure 46) on spindle (AW) is aligned with center of groove (CB) on conveyor (Z).
6. Using a 3mm hex key wrench (AQ of Figure 37), tighten two set screws (AR) on each bearing and head plate assembly (AS).
7. On closed end of drive spindle assembly (BL of Figure 36), install bearing cover (AP).
8. Install gearmotor mounting package. See accessory instructions.

B – Idler Pulley Installation

1. Make sure bearing surfaces on idler spindle are free of nicks and burrs. Slide bearing and head plate assembly (BV of Figure 44) on idler spindle (BW).
2. Repeat step 1 for opposite side of idler spindle.

IMPORTANT: Loosely install a spacer (BS of Figures 41 and 47) on each side of tail assembly (AN) prior to installing tail assembly on conveyor.

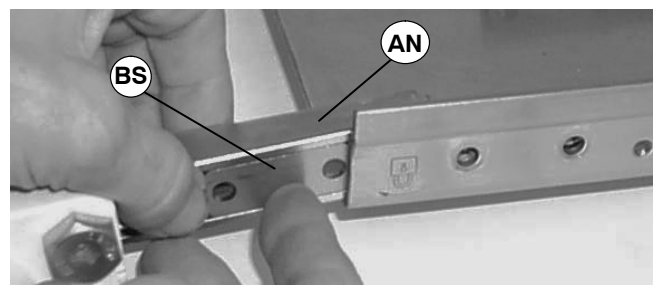

Figure 47

3. Position tail assembly (AN) and two spacers (BS) on conveyor (Z).

Preventive Maintenance and Adjustment

IMPORTANT: During idler pulley installation, orient both pinion ends (BQ of Figure 48) so they engage the same tooth positions on their respective racks.

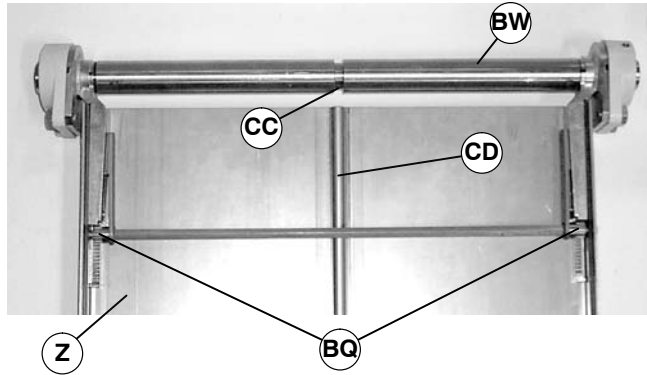

Figure 48

4. Loosely install two pinion ends (BQ of Figures 41 and 48), hex pinion (BO) and clamp blocks (BR) on tail assembly (AN) and conveyor (Z) with four M6x20mm hex head cap screws (AM of Figure 40), two sleeves (BP) and two M6x25mm hex head cap screws (AO).

5. While holding hex pinion (BO of Figure 39) with a 3/8" open-end wrench, tighten two screws (AO of Figure 39 and BH of Figure 41) to 33 in-lb (3.7 Nm).
6. Tighten four screws (AM of Figure 40) to 33 in-lb (3.7 Nm).

IMPORTANT: Before tightening set screws on bearing and head plate assemblies, make sure that center of groove (CC of Figure 48) on spindle (BW) is in line with center of groove (CD) on conveyor (Z).

7. Make sure center of groove (CC of Figure 48) on spindle (BW) is aligned with center of groove (CD) on conveyor (Z).
8. Using a 3mm hex key wrench (AQ of Figure 43), tighten two set screws (BU) on each bearing and head plate assembly (BV).
9. Install two bearing covers (BT of Figure 42) on tail assembly (AN).
10. Install gearmotor mounting package. See accessory instructions.

Service Parts

NOTE: For replacement parts other than those shown in this section, contact an authorized Dorner Service Center or the factory. Key Service Parts and Kits are identified by the Performance Parts Kits logo . Dorner recommends keeping these parts on hand.

Drive End Components

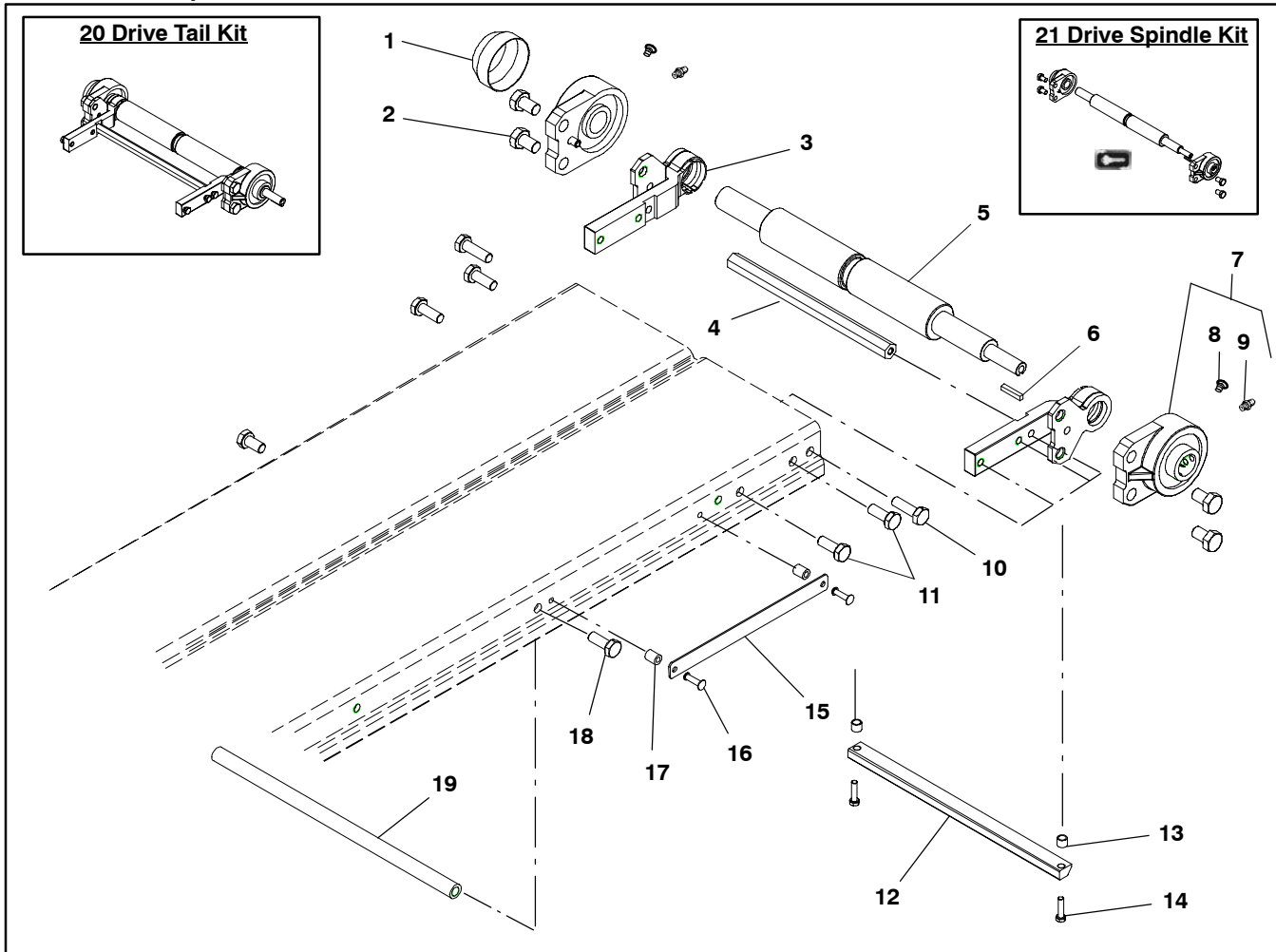

Item	Part Number	Description
1	802-133	Bearing Cover
2	961016MSS	Hex Head Cap Screw M10-1.5x16mm
3	456055	Head Plate, Fixed, Welded
4	4588WW	Cross Support Post
5	4575WW	Drive Spindle, SS
6	980422MSS	Square Key 4mm x 22mm
7	456080	Flange Bearing Assembly (Includes Items 8 and 9)
8	807-1336	Plastic Plug
9	810-187	Grease Fitting, SS 1/4-28
10	960620MSS	Hex Head Cap Screw M6-1.0x20mm
11	960616MSS	Hex Head Cap Screw M6-1.0x16mm
12	4557WW	Washdown Wiper Option
13	456049	Sleeve

14	960520MSS	Hex Head Cap Screw M5-0.80 x 20mm
15	456034	Name Tag
16	914-008	Rivet
17	807-1301	Spacer
18	960612MSS	Hex Head Cap Screw M6-1.0x12mm
19	4525WWMSS	Frame Support Post
20	73DT-WW	Drive Tail Kit w/o Wiper (Includes Items 1 through 11)
	73DTWA-WW	Drive Tail Kit w/Wiper - Shaft Position A or B (Includes Items 1 through 14)
	73DTWD-WW	Drive Tail Kit w/Wiper - Shaft Position C or D (Includes Items 1 through 14)
21	73DS-WW	Drive Spindle Kit (Includes Items 1, 2, and 5 through 9)

WW = Conveyor width ref.: 02, 03, 04, 05, 06, 08, 10, 12, 18

Tension End Components

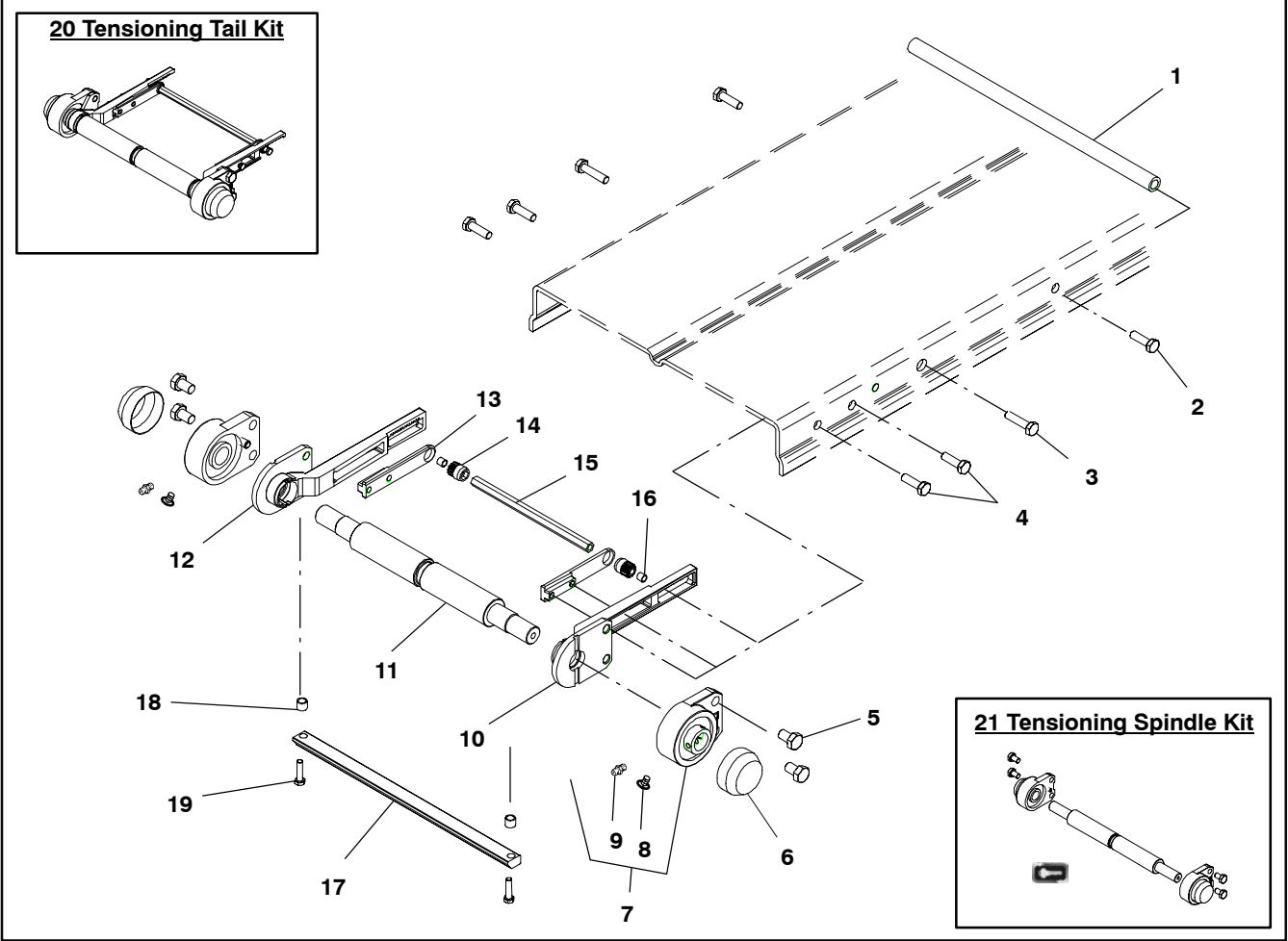

Item	Part Number	Description
1	4525WWSS	Frame Support Post
2	960612MSS	Hex Head Cap Screw M6-1.0x12mm
3	960625MSS	Hex Head Cap Screw M6-1.0x25mm
4	960620MSS	Hex Head Cap Screw M6-1.0x20mm
5	961016MSS	Hex Head Cap Screw M10-1.5 x 16mm
6	802-133	Bearing Cover
7	456080	Flange Bearing Assembly (Includes Items 8 and 9)
8	807-1336	Plastic Plug
9	810-187	Grease Fitting, SS 1/4-28
10	456057	Head Plate Tension RH
11	4576WW	Idler Spindle SS
12	456058	Head Plate Tension LH

13	456041	Clamp Block
14	456045	Pinion End
15	4563WW	Hex Pinion
16	456049	Sleeve .312 OD x .035 Wall
17	4557WW	Washdown Wiper Option
18	456049	Sleeve
19	960520MSS	Hex Head Cap Screw M5-0.80 x 20mm
20	73TT-WW	Tension Tail Kit w/o Wiper (Includes Items 3 through 16)
	73TTW-WW	Tension Tail Kit w/Wiper (Includes Items 3 through 19)
21	73TS-WW	Tension Spindle Kit (Includes Items 5, 6, 7, 8, 9, and 11)
WW = Conveyor width ref.: 02, 03, 04, 05, 06, 08, 10, 12, 18		

Service Parts

Conveyor Frame and Extension

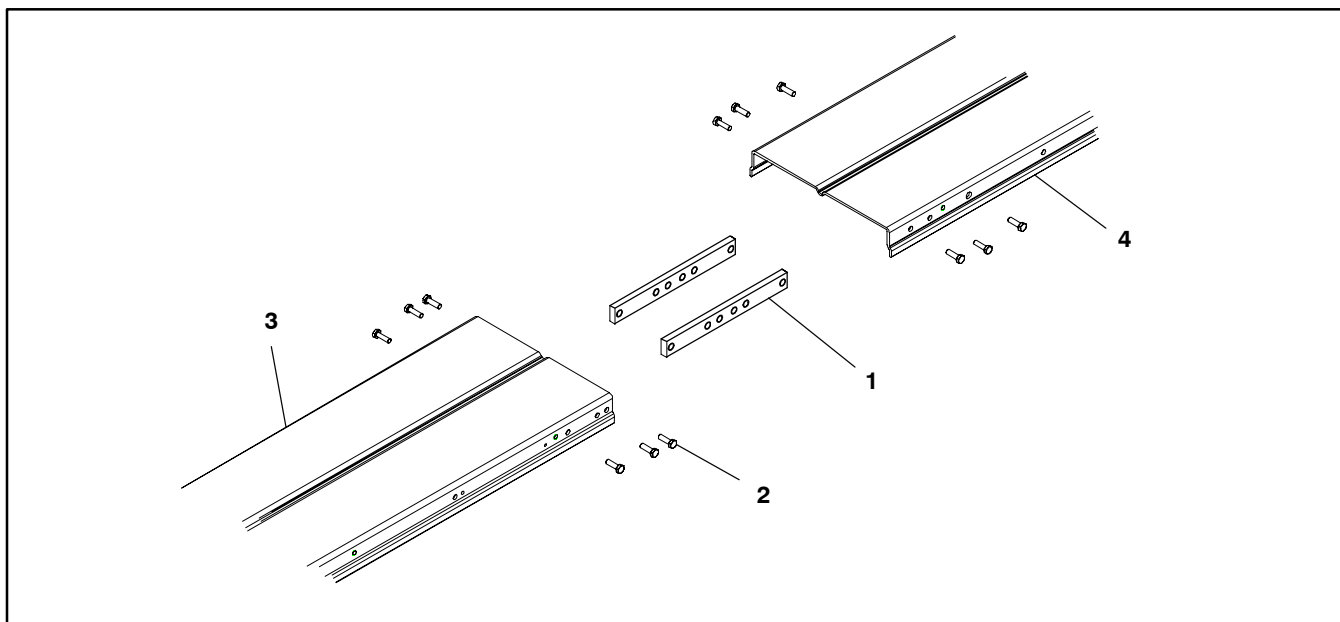

Item	Part Number	Description
1	456046	Frame Connecting Bar
2	960610MSS	Hex Head Cap Screw M6-1.0x10mm

3	See Conveyor Frame chart	Conveyor Frame
4	See Conveyor Frame chart	Conveyor Frame Extension

Items 3 and 4: Conveyor Frame		
Length	Frame Part Number	Frame Extension Part Number
2' (610mm)	4730WW-01860	n/a
3' (914mm)	4730WW-03060	n/a
4' (1219mm)	4730WW-04260	n/a
5' (1524mm)	4730WW-05460	n/a
6' (1829mm)	4730WW-06660	n/a
7' (2134mm)	4730WW-07860	n/a
8' (2438mm)	4730WW-09060	n/a
9' (2743mm)	4730WW-10260	n/a

10' (3048mm)	4730WW-11460	n/a
11' (3353mm)	4730WW-12660	n/a
12' (3658mm)	4730WW-13860	n/a
13' (3962mm)	4730WW-07860	4750WW
14' (4267mm)	4730WW-09060	4750WW
15' (4572mm)	4730WW-10260	4750WW
16' (4877mm)	4730WW-11460	4750WW
17' (5182mm)	4730WW-12660	4750WW
18' (5486mm)	4730WW-13860	4750WW
WW = Conveyor width ref.: 02, 03, 04, 05, 06, 08, 10, 12, 18		

-21 1" (25mm) Sanitary Bolt-On High Sides

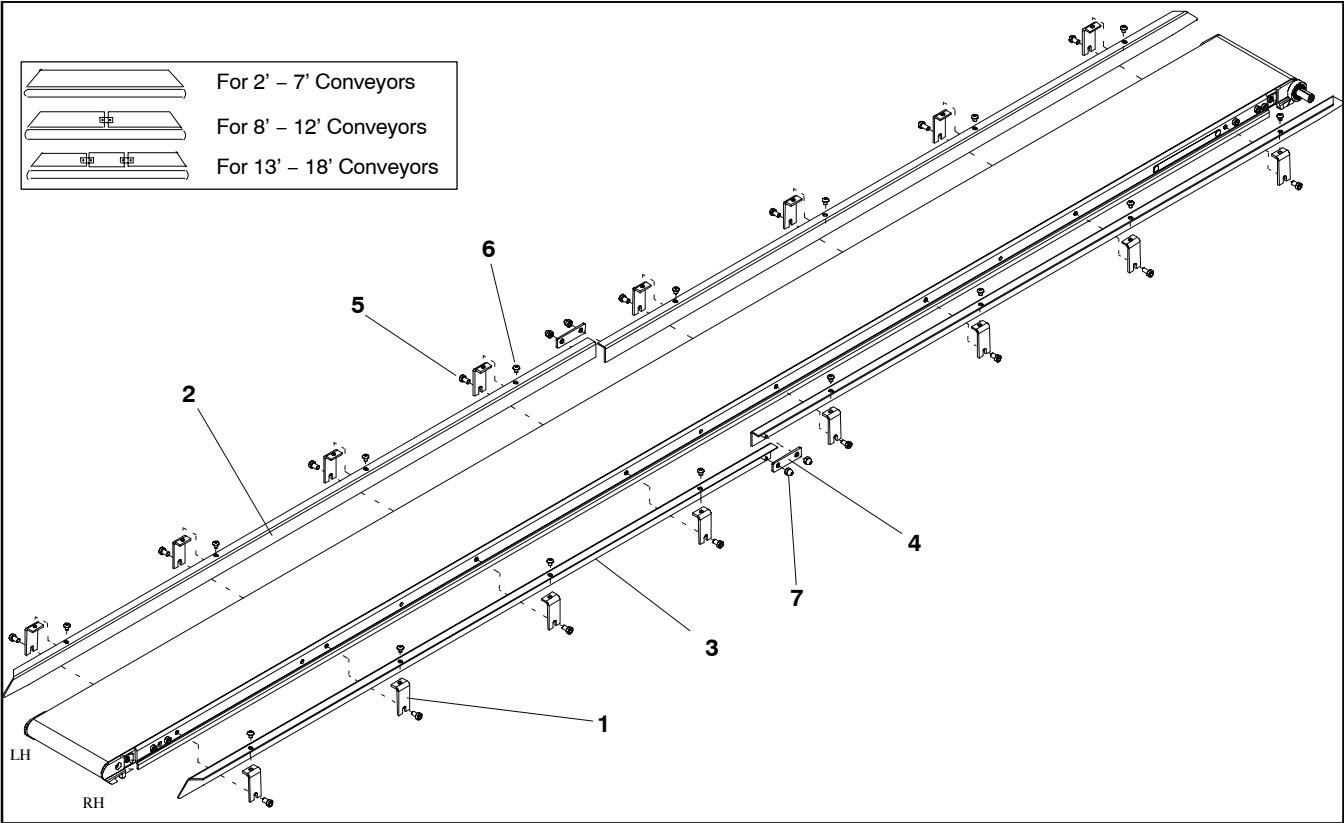

Item	Part Number	Description
1	462150MSS	1" Guide Mounting Bracket
2	See chart below	1" Guide LH
3	See chart below	1" Guide RH
4	450188SS	Guide Tie Plate
5	960608MSS	M6-1.0 x 8mm Hex Head Screw
6	960506MSS	M5-0.8 x 6mm Hex Head Screw
7	990508MSS	M5 Acorn Nut

Conveyor Length		Tail End Guide	Center Guide	Drive End Guide
2' (610mm)	Right Hand	462132SSP	N/A	N/A
	Left Hand	462132SSP	N/A	N/A
3' (914mm)	Right Hand	462133SSP	N/A	N/A
	Left Hand	462133SSP	N/A	N/A
4' (1219mm)	Right Hand	462134SSP	N/A	N/A
	Left Hand	462134SSP	N/A	N/A
5' (1524mm)	Right Hand	462135SSP	N/A	N/A
	Left Hand	462135SSP	N/A	N/A
6' (1829mm)	Right Hand	462136SSP	N/A	N/A
	Left Hand	462136SSP	N/A	N/A
7' (2134mm)	Right Hand	462137SSP	N/A	N/A
	Left Hand	462137SSP	N/A	N/A

8' (2438mm)	Right Hand	462154SSP	N/A	462144SSP
	Left Hand	462144SSP	N/A	462154SSP
9' (2743mm)	Right Hand	462155SSP	N/A	462144SSP
	Left Hand	462145SSP	N/A	462154SSP
10' (3048mm)	Right Hand	462155SSP	N/A	462145SSP
	Left Hand	462145SSP	N/A	462155SSP
11' (3353mm)	Right Hand	462156SSP	N/A	462145SSP
	Left Hand	462146SSP	N/A	462155SSP
12' (3658mm)	Right Hand	462156SSP	N/A	462146SSP
	Left Hand	462146SSP	N/A	462156SSP
13' (3962mm)	Right Hand	462156SSP	462163SSP	462144SSP
	Left Hand	462146SSP	462163SSP	462154SSP
14' (4267mm)	Right Hand	462156SSP	462163SSP	462145SSP
	Left Hand	462146SSP	462163SSP	462155SSP
15' (4572mm)	Right Hand	462156SSP	462163SSP	462146SSP
	Left Hand	462146SSP	462163SSP	462156SSP
16' (4877mm)	Right Hand	462156SSP	462166SSP	462144SSP
	Left Hand	462146SSP	462166SSP	462154SSP
17' (5182mm)	Right Hand	462156SSP	462166SSP	462145SSP
	Left Hand	462146SSP	462166SSP	462155SSP
18' (5486mm)	Right Hand	462156SSP	462166SSP	462146SSP
	Left Hand	462146SSP	462166SSP	462156SSP

Service Parts

-22 2" (51mm) Sanitary Bolt – On High Sides

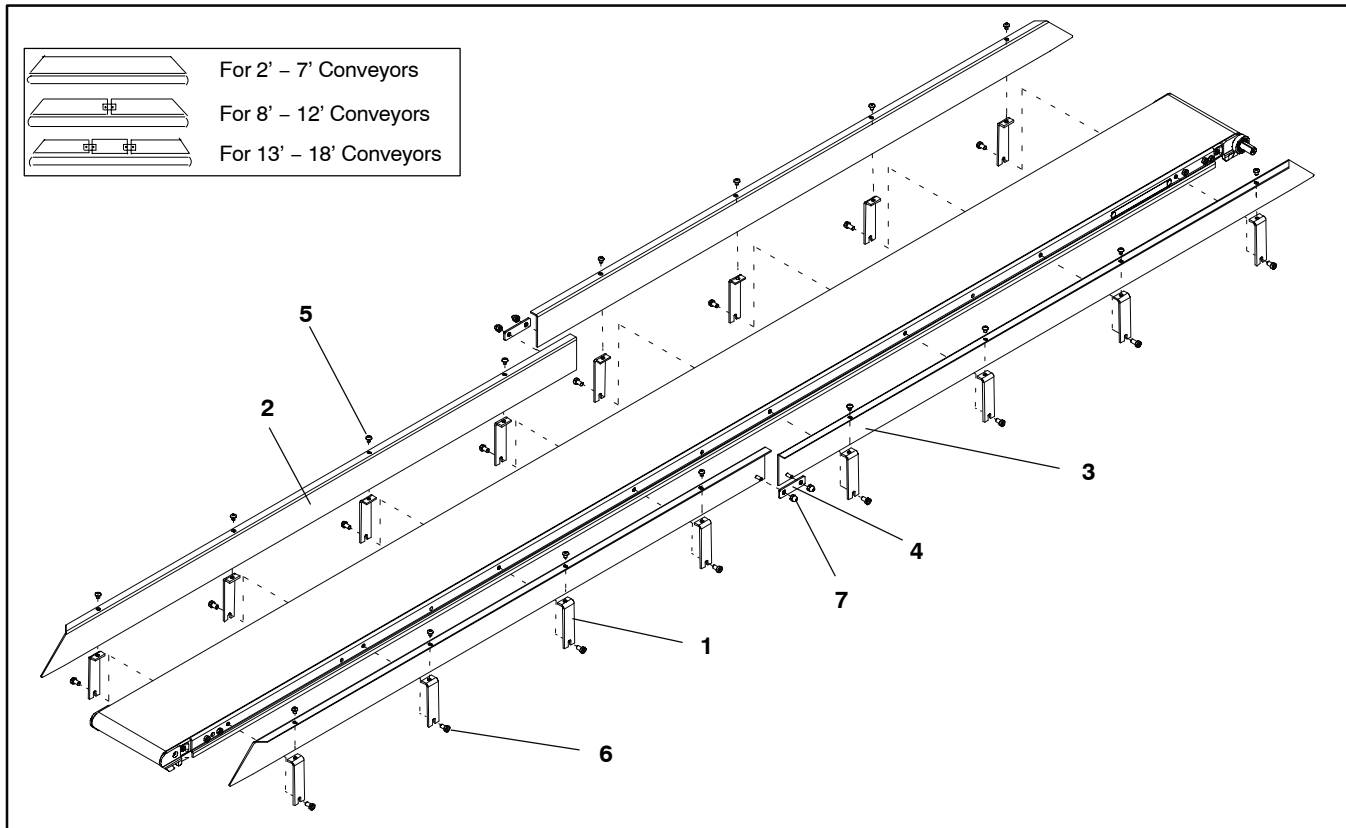

Item	Part Number	Description
1	462250MSS	2" Guide Mounting Bracket
2	See chart below	2" Guide LH
3	See chart below	2" Guide RH
4	450188SS	Guide Tie Plate
5	960608MSS	M6-1.0 x 10mm Hex Head Screw
6	960506MSS	M5-0.8 x 6mm Hex Head Screw
7	990508MSS	M5 Acorn Nut

Conveyor Length		End Guide	Center Guide	End Guide
2' (610mm)	Right Hand	462232SSP	N/A	N/A
	Left Hand	462232SSP	N/A	N/A
3' (914mm)	Right Hand	462233SSP	N/A	N/A
	Left Hand	462233SSP	N/A	N/A
4' (1219mm)	Right Hand	462234SSP	N/A	N/A
	Left Hand	462234SSP	N/A	N/A
5' (1524mm)	Right Hand	462235SSP	N/A	N/A
	Left Hand	462235SSP	N/A	N/A
6' (1829mm)	Right Hand	462236SSP	N/A	N/A
	Left Hand	462236SSP	N/A	N/A
7' (2134mm)	Right Hand	462237SSP	N/A	N/A
	Left Hand	462237SSP	N/A	N/A

8' (2438mm)	Right Hand	462254SSP	N/A	462244SSP
	Left Hand	462244SSP	N/A	462254SSP
9' (2743mm)	Right Hand	462255SSP	N/A	462244SSP
	Left Hand	462245SSP	N/A	462254SSP
10' (3048mm)	Right Hand	462255SSP	N/A	462245SSP
	Left Hand	462245SSP	N/A	462255SSP
11' (3353mm)	Right Hand	462256SSP	N/A	462245SSP
	Left Hand	462246SSP	N/A	462255SSP
12' (3658mm)	Right Hand	462256SSP	N/A	462246SSP
	Left Hand	462246SSP	N/A	462256SSP
13' (3962mm)	Right Hand	462256SSP	462263SSP	462244SSP
	Left Hand	462246SSP	462263SSP	462254SSP
14' (4267mm)	Right Hand	462256SSP	462263SSP	462245SSP
	Left Hand	462246SSP	462263SSP	462255SSP
15' (4572mm)	Right Hand	462256SSP	462263SSP	462246SSP
	Left Hand	462246SSP	462263SSP	462256SSP
16' (4877mm)	Right Hand	462256SSP	462266SSP	462244SSP
	Left Hand	462246SSP	462266SSP	462254SSP
17' (5182mm)	Right Hand	462256SSP	462266SSP	462245SSP
	Left Hand	462246SSP	462266SSP	462255SSP
18' (5486mm)	Right Hand	462256SSP	462266SSP	462246SSP
	Left Hand	462246SSP	462266SSP	462256SSP

-23 Sanitary Fully Adjustable UHMW Guide

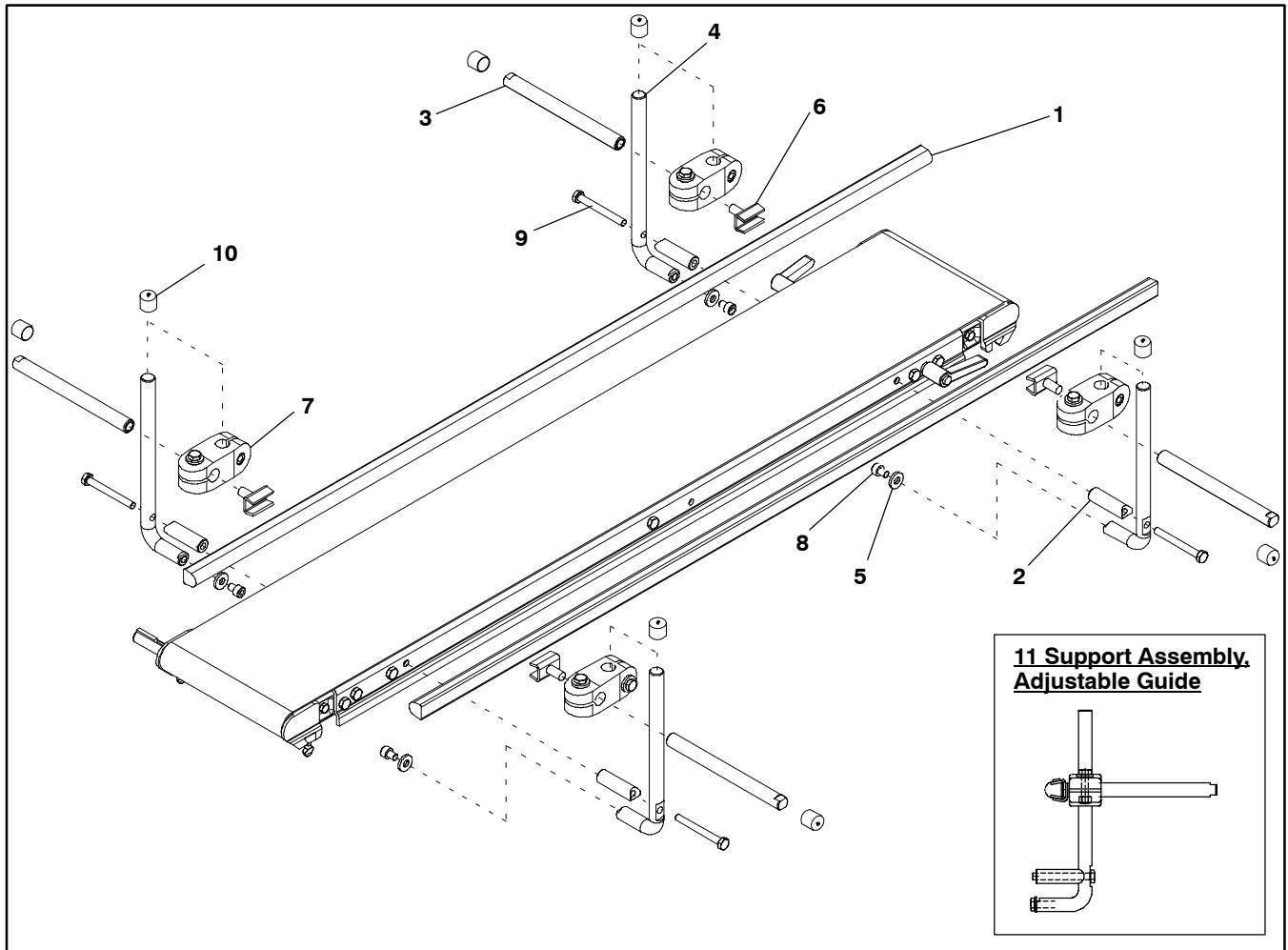

Item	Part Number(s)	Description
1	462332	Guide Mounting Rail 2' (610mm)
	462333	Guide Mounting Rail 3' (914mm)
	462334	Guide Mounting Rail 4' (1219mm)
	462335	Guide Mounting Rail 5' (1524mm)
	462336	Guide Mounting Rail 6' (1829mm)
	462337	Guide Mounting Rail 7' (2134mm)
	462338	Guide Mounting Rail 8' (2438mm)
	462339	Guide Mounting Rail 9' (2743mm)
	462340	Guide Mounting Rail 10' (3053mm)
	462341	Guide Mounting Rail 11' (3353mm)
	462342	Guide Mounting Rail 12' (3658mm)
	462337 462336	Guide Mounting Rail 13' (3962mm)
	462337 462337	Guide Mounting Rail 14' (4267mm)
	462338 462337	Guide Mounting Rail 15' (4572mm)
	462338 462338	Guide Mounting Rail 16' (4877mm)
	462339 462338	Guide Mounting Rail 17' (5182mm)
	462339 462339	Guide Mounting Rail 18' (5486mm)

2	462351MSS	Shaft Brace
3	462352SS	Horizontal Shaft Mounting Guide
4	462350MSS	Vertical Shaft Adjustable Guide
5	911-201	Flat Washer
6	807-978	Guide Clamp
7	450187MSS	Cross Block
8	960608MSS	Hex Head Screw (Metric) M6-1.0 x 8mm
9	960650MSS	Hex Head Screw (Metric) M6-1.0 x 50mm
10	807-948	Cap, Vinyl
11	462300MSS	Support Assembly, Adjustable Guide (Includes Items: 2 through 10)

Service Parts

-24 Sanitary Adjustable Width UHMW Guides

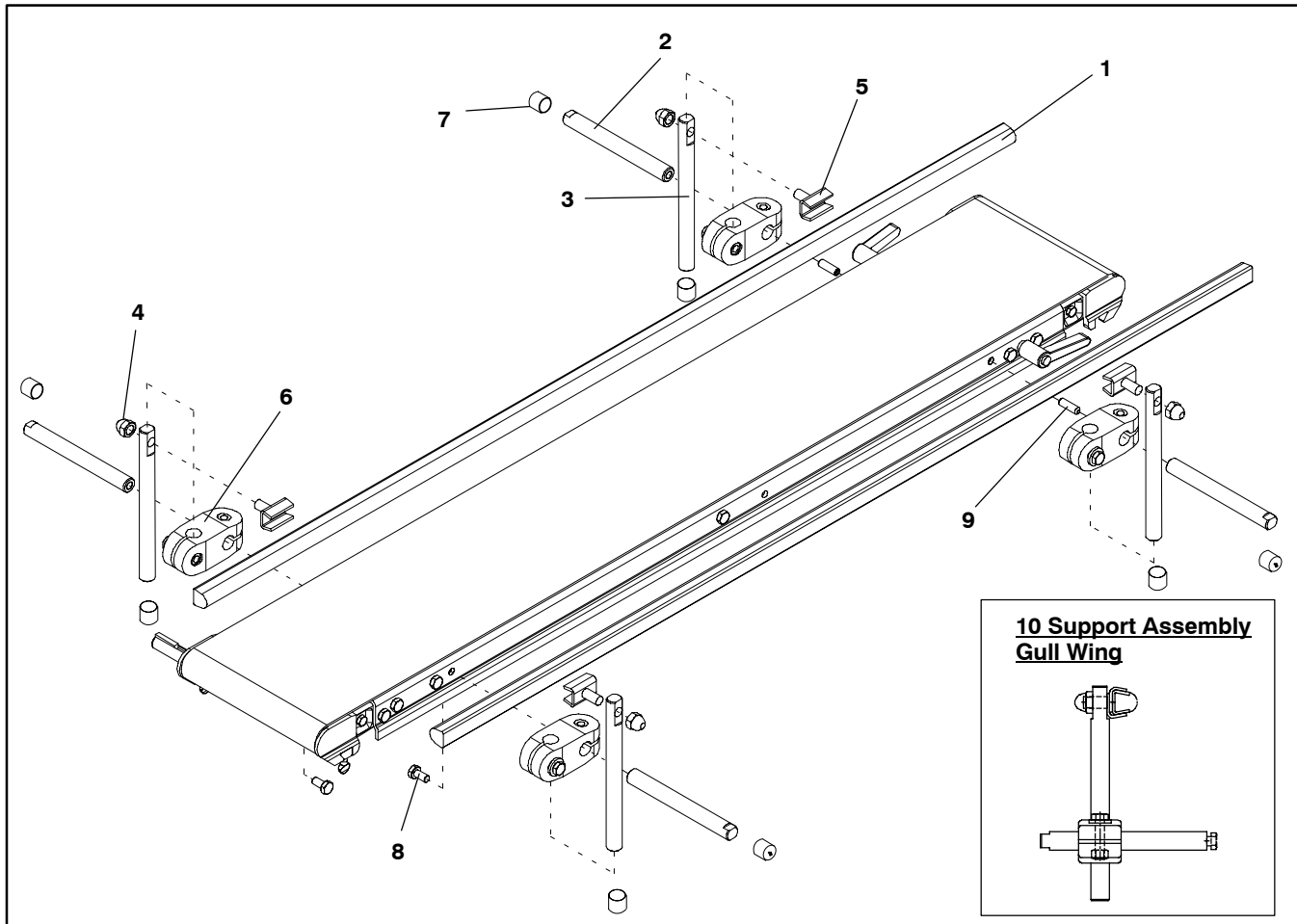

Item	Part Number(s)	Description
1	462332	Guide Mounting Rail 2' (610mm)
	462333	Guide Mounting Rail 3' (914mm)
	462334	Guide Mounting Rail 4' (1219mm)
	462335	Guide Mounting Rail 5' (1524mm)
	462336	Guide Mounting Rail 6' (1829mm)
	462337	Guide Mounting Rail 7' (2134mm)
	462338	Guide Mounting Rail 8' (2438mm)
	462339	Guide Mounting Rail 9' (2743mm)
	462340	Guide Mounting Rail 10' (3053mm)
	462341	Guide Mounting Rail 11' (3353mm)
	462342	Guide Mounting Rail 12' (3658mm)
	462337 462336	Guide Mounting Rail 13' (3962mm)
	462337 462337	Guide Mounting Rail 14' (4267mm)
	462338 462337	Guide Mounting Rail 15' (4572mm)
	462338 462338	Guide Mounting Rail 16' (4877mm)
	462339 462338	Guide Mounting Rail 17' (5182mm)
	462339 462339	Guide Mounting Rail 18' (5486mm)

2	462452MSS	Horizontal Shaft Gullwing Guide
3	462450MSS	Vertical Shaft Gullwing Guide
4	807-977	Acorn Nut
5	807-978	Guide Clamp
6	450187MSS	Cross Block
7	807-948	Cap, Vinyl
8	960612MSS	Hex Head Cap Screw M6-1.0 x 12mm
9	970620MSS	Socket Head Set Screw M6-1.0 x 20mm
10	462400MSS	Support Assembly, Gull Wing (In- cludes Items: 2 through 7)

Sanitary 2" (51mm) Through 6" (152mm) Wide Flat and Cleated Belt Return Roller

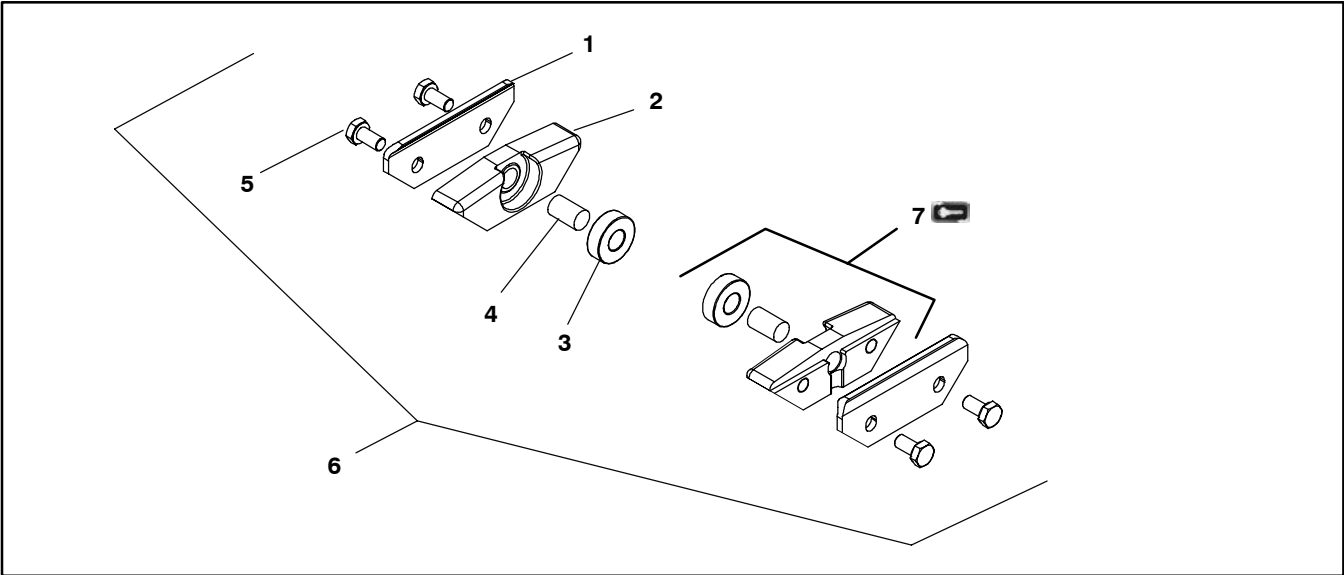

Item	Part Number	Description
1	450593	Clamp Plate
2	450596	Mounting Block
3	802-123	Bearing

4	913-103	Dowel Pin
5	960612MSS	Hex Head Screw M6-1.0 x 12mm
6	450594	Return Roller Assembly
7	450595	Roller Assembly (3 piece)

Sanitary 8" (203mm) Through 18" (457mm) Wide Flat Belt Return Roller

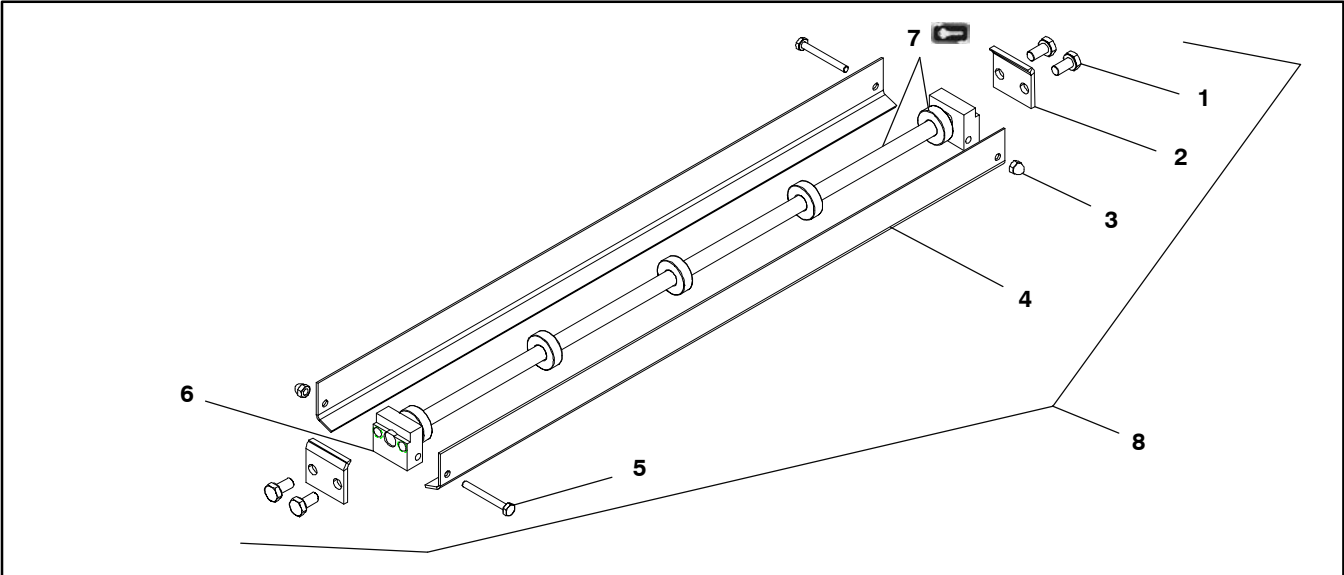

Item	Part Number	Description
1	960612MSS	Hex Head Cap Screw M6-1.0 x 12mm
2	450628	Clamp Plate
3	990408MSS	Acorn Nut M4-0.70
4	4516WW	Return Roller Guard

5	960435MSS	Hex Head Cap Screw M4-0.70 x 35mm
6	450626	Mounting Block
7	4517WW	Shaft/Bearing Assembly
8	4514WW	Return Roller Assembly
WW = Conveyor width ref.: 08, 10, 12, 18		

Service Parts

Conveyor Mounting Brackets

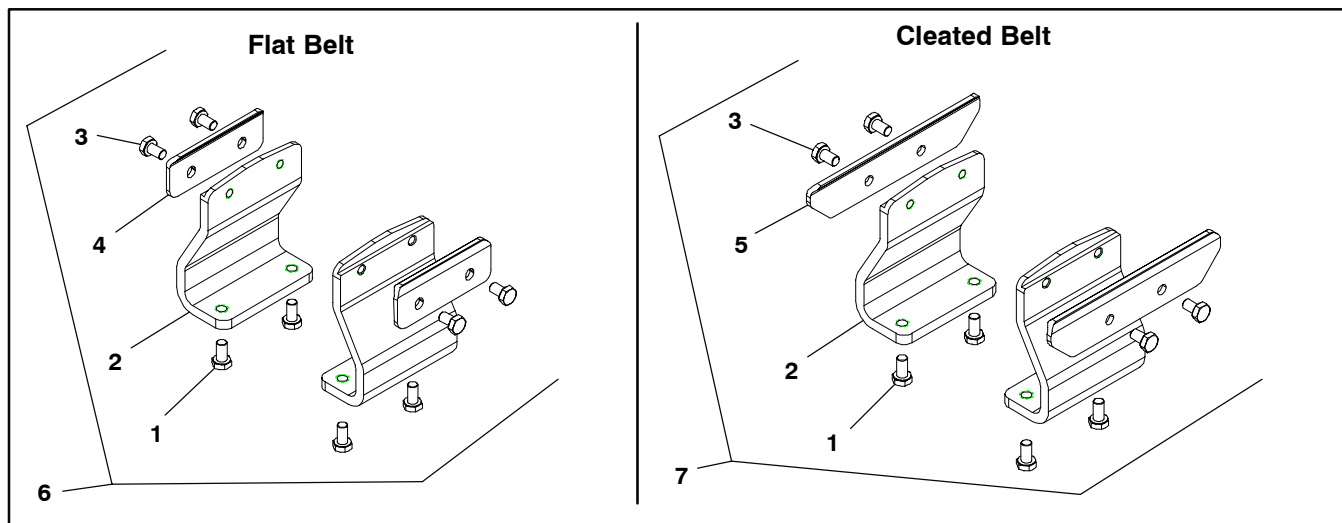

Item	Part Number	Description
1	960612MSS	Hex Head Cap Screw M6-1.0 x 12mm
2	450590	Stand/Conveyor Ear Mount Bracket
3	960610MSS	Hex Head Cap Screw M6-1.0 x 10mm

4	492564SS	Clamp Plate - Flat Belt
5	492566SS	Clamp Plate - Cleated Belt
6	492564SS	Mount Assembly - Flat Belt
7	492566SS	Mount Assembly - Cleated Belt

Configuring Conveyor Belt Part Number

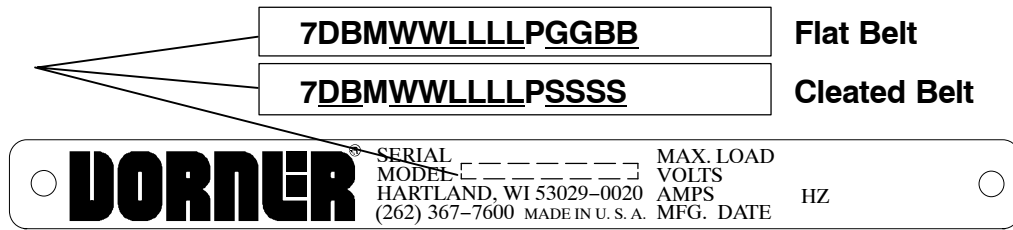

Figure 49

Flat Belt Conveyor

Refer to your serial and model number plate (Figure 49). From the model number, determine conveyor width (WW), length (LLLL), and belt type (BB). Use data to configure belt part number as indicated below.

7D-WWLLLL / BBV

72- _____ / ____ V
(Fill In)

EXAMPLE:

731M030200A0102 Conveyor

7300 Series end drive, flat belt conveyor with mounting brackets, USA English, 3" (76mm) wide x 2.0 ft (610mm) long, shaft position A, guide profile 01 and belt type /02 (general purpose, fused finger)

72-030200/02V Belt

Cleated Belt Conveyor

Refer to your serial and model number plate (Figure 49). From the model number, determine conveyor type (D), width (WW), length (LLLL), belt cleat type (B), and cleat spacing (SSSS). Use data to configure belt part number as indicated below.

7D-WWLLLLBSSSSV

7 - _____ V
(Fill In)

EXAMPLE:

75AM030200A0659 Conveyor

7300 Series standard cleated belt conveyor with mounting brackets, A-style cleat, USA English, 3" (76mm) wide x 2.0 ft (610mm) long, shaft position A, and 6.59 in (167.4mm) cleat spacing

74-030200A0659V Belt

Return Policy

No returns will be accepted without prior written factory authorization. When calling for authorization, please have the following information ready for the Dorner Factory representative or your local distributor:

1. Name and address of customer.
2. Item(s) being returned.
3. Reason for return.
4. Customer's original order number used when ordering the item(s).
5. Dorner or distributor invoice number.

A representative will discuss action to be taken on the Returned items and provide a Returned Goods Authorization Number to reference.

There will be a 15% restocking charge on all new items returned for credit where Dorner was not at fault. These will not be accepted after 60 days from original invoice date. The restocking charge covers inspection, cleaning, disassembly, and reissuing to inventory.

If a replacement is needed prior to evaluation of returned item, a purchase order must be issued. Credit (if any) is issued only after return and evaluation is complete.

Dorner has representatives throughout the world. Feel free to contact Dorner for the name of your local representative. Our technical sales and service staff will gladly help with your questions on Dorner products.

For a copy of Dorner's Limited Warranty, contact factory, distributor, service center or visit our website @ www.dorner.com

**For replacement parts, contact an authorized
Dorner Service Center or the factory.**

DORNER[®]

Dorner Mfg. Corp. reserves the right to change or discontinue products without notice. All products and services are covered in accordance with our standard warranty. All rights reserved. ©Dorner Mfg. Corp. 2000

DORNER MFG. CORP.

975 Cottonwood Drive, PO Box 20
Hartland, WI 53029-0020 USA

USA

TEL 1-800-397-8664 (USA)

FAX 1-800-369-2440 (USA)

Internet: www.dorner.com

Outside the USA:

TEL 1-262-367-7600

FAX 1-262-367-5827