



# 2100, 2200, 4100, 6200, MPB Series Side Mount Drive Package for Standard Load 90° Industrial 60 Hz Gearmotors

Installation, Maintenance & Parts Manual



DORNER MFG. CORP.  
P.O. Box 20 • 975 Cottonwood Ave.  
Hartland, WI 53029-0020 USA

INSIDE THE USA  
TEL: 1-800-397-8664  
FAX: 1-800-369-2440

OUTSIDE THE USA  
TEL: 262-367-7600  
FAX: 262-367-5827

For other service manuals visit our website at:  
[www.dorner.com/service\\_manuals.asp](http://www.dorner.com/service_manuals.asp)

---

# Table of Contents

---

Introduction .....	2	Preventive Maintenance and Adjustment .....	11
Warnings – General Safety .....	3	Required Tools .....	11
Product Description .....	4	Gear Reducer Replacement .....	11
Specifications .....	4	Motor Replacement .....	12
Installation .....	7	Service Parts.....	14
Required Tools.....	7	Side Mount Drive Package for 90° 60 Hz Gearmotors..	14
Mounting.....	7	4100 Adapter Components .....	15
For 4100 and 2100 Flat Belt Conveyors .....	8	Gearmotors .....	15
For 6200, 2200, MPB and 2100 Cleated Belt		Return Policy.....	16
Conveyors.....	9		

---

## Introduction

---

<b>IMPORTANT</b>
------------------

<i>Some illustrations may show guards removed. DO NOT operate equipment without guards.</i>
---

Upon receipt of shipment:

- Compare shipment with packing slip. Contact factory regarding discrepancies.
- Inspect packages for shipping damage. Contact carrier regarding damage.
- Accessories may be shipped loose. See accessory instructions for installation.

Dorner has convenient, pre-configured kits of Key Service Parts for all conveyor products. These time saving kits are easy to order, designed for fast installation, and guarantee you will have what you need when you need it. Key Parts and Kits are marked in the Service Parts section of this manual with the Performance Parts Kits logo  .

Dorner 2100 Series conveyors are covered by the following patent numbers: 5131529, 5174435, and corresponding patents and patent applications in other countries.

Dorner 4100 Series conveyors are covered by patent number 3923148 and corresponding patents and patent applications in other countries.

Dorner 2200, 6200 & MPB Series conveyors are covered by patent number 5174435 and corresponding patents and patent applications in other countries.

Dorner's Limited Warranty applies.

Dorner reserves the right to make changes at any time without notice or obligation.

## Warnings – General Safety

### WARNING

The safety alert symbol, black triangle with white exclamation, is used to alert you to potential personal injury hazards.

### DANGER



Climbing, sitting, walking or riding on conveyor will cause severe injury.  
**KEEP OFF CONVEYORS.**

### DANGER



**Do NOT OPERATE CONVEYORS IN AN EXPLOSIVE ENVIRONMENT.**

### WARNING



Exposed moving parts can cause severe injury.  
**LOCK OUT POWER** before removing guards or performing maintenance.

### WARNING



Gearmotors may be **HOT**.  
**DO NOT TOUCH** Gearmotors.

### WARNING



Exposed moving parts can cause severe injury.  
**REPLACE ALL GUARDS BEFORE RUNNING CONVEYOR.**

### WARNING



Dorner cannot control the physical installation and application of conveyors. Taking protective measures is the responsibility of the user.  
When conveyors are used in conjunction with other equipment or as part of a multiple conveyor system, **CHECK FOR POTENTIAL PINCH POINTS** and other mechanical hazards before system start-up.

### WARNING



**MPB Series Conveyors are not reversible.** Reversing creates pinch points which can cause severe injury.  
**DO NOT REVERSE MPB SERIES CONVEYORS.**

# Product Description

Refer to Figure 1 for typical conveyor components.

- |   |                  |
|---|------------------|
| A | Conveyor         |
| B | Mounting Bracket |
| C | Gearmotor        |
| D | Coupling         |
| E | Inspection Plug  |

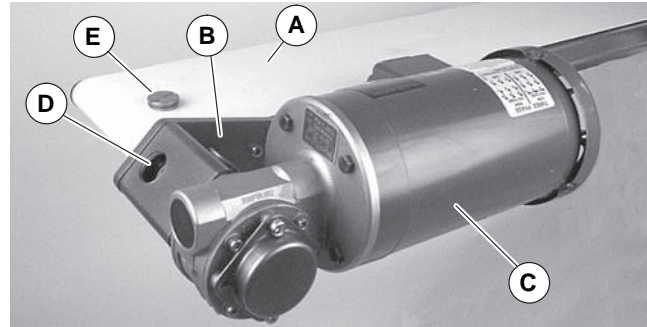

Figure 1

# Specifications

## Gearmotor Mounting Package Models:

Example:

- 6 M S H S WW A
- Mount Position = A, B, C or D (see detail to the right)
  - Conveyor Width Reference\*
  - Gearmotor Type = Standard Load, Industrial
  - Output Shaft Type = 90° Industrial
  - Mount Style = Side Mount
  - Language Code = U.S. English
- 2 = 2100 Series Conveyor  
 22 = 2200 Series Series Conveyors  
 4 = 4100 Series Conveyor  
 6 = 6200 Series Conveyor  
 2P = MPB Series Conveyor

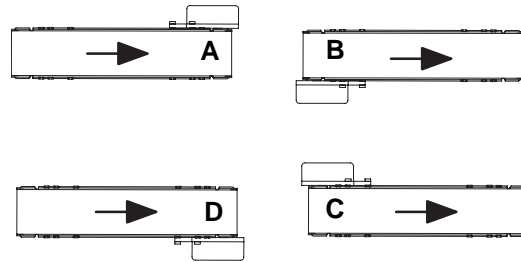

\* See Ordering and Specifications Catalog for details.

## Table 1: Gearmotor Specifications

	Single Phase	Three Phase	DC Variable Speed
Output Power	0.25 hp (0.19 kw)		
Input Voltage	115 Volts A.C.	208 to 230/460 Volts A.C.	130 Volts D.C.
Input Frequency	60 Hz		N/A
Input Current	5.0 Amperes	1.2 /0.6 Amperes	2.2 Amperes
Motor RPM	1725		2500
Gearmotor Ratios	5:1, 10:1, 20:1, 40:1, 60:1		
Frame Size	NEMA 42 CZ		
Motor Type	Totally Enclosed, Fan-cooled		

# Specifications

**Table 2: Belt Speeds for Standard Load Fixed Speed 90° 60 Hz Gearmotors on 2200 Series Conveyors**

Gearmotors				Belt Speed	
Part Number	RPM	In lb	N-m	Ft/min	M/min
32M060HL4(vp)F(n)	29	226	25.5	10.0	3.0
32M040HL4(vp)F(n)	43	237	26.8	15.0	4.6
32M020HL4(vp)F(n)	86	142	16	30.0	9.1
32M010HL4(vp)F(n)	173	78	8.8	61.0	18.6
32M005HL4(vp)F(n)	345	41	4.6	121.0*	36.9*

(vp) = voltage and phase

11 = 115 V, 1-phase

23 = 208 – 230/460 V, 3-phase

(n) = Reversing Capability

N = No Reversing Capability

R = With Reversing Capability

\* = Nosebar transfers operate at maximum 77Ft/min (23.5M/min) belt speed

**Table 3: Belt Speeds for Standard Load Variable Speed 90° DC Gearmotors on 2200 Series Conveyors**

Gearmotors				Belt Speed	
Part Number	Max RPM	In-lb	N-m	Ft/min	M/min
32M060HLD3DEN	42	198	22.4	1.8 – 14.0	0.5 – 4.5
32M040HLD3DEN	63	163	18.4	2.6 – 22.0	0.8 – 6.7
32M020HLD3DEN	125	98	11.1	5.3 – 44.0	1.6 – 13.0
32M010HLD3DEN	250	54	6.1	10.0 – 88.0*	3.2 – 27.0*
32M005HLD3DEN	500	28	3.2	21.0 – 176.0*	6.4 – 54.0*

\* = Nosebar transfers operate at maximum 77Ft/min (23.5M/min) belt speed

**Table 4: Belt Speeds for Standard Load Fixed Speed 90° 60 Hz Gearmotors on 2100, 4100 & 6200 Series Conveyors**

Gearmotors				Belt Speed	
Part Number	RPM	In lb	N-m	Ft/min	M/min
32M060HL4(vp)F(n)	29	226	25.5	8.0	2.4
32M040HL4(vp)F(n)	43	237	26.8	12.0	3.7
32M020HL4(vp)F(n)	86	142	16	25.0	7.6
32M010HL4(vp)F(n)	173	78	8.8	49.0	14.9
32M005HL4(vp)F(n)	345	41	4.6	99.0	30.2

(vp) = voltage and phase

11 = 115 V, 1-phase

23 = 208 – 230/460 V, 3-phase

(n) = Reversing Capability

N = No Reversing Capability

R = With Reversing Capability

**Table 5: Belt Speeds for Standard Load Variable Speed 90° DC Gearmotors on 2100, 4100 & 6200 Series Conveyors**

Gearmotors				Belt Speed	
Part Number	Max RPM	In-lb	N-m	Ft/min	M/min
32M060HLD3DEN	42	198	22.4	1.4 – 12	0.4 – 3.6
32M040HLD3DEN	63	163	18.4	2.1 – 18	0.7 – 5.4
32M020HLD3DEN	125	98	11.1	4.3 – 36	1.3 – 11
32M010HLD3DEN	250	54	6.1	9.0 – 71	2.6 – 22
32M005HLD3DEN	500	28	3.2	17 – 143	5.2 – 43

# Specifications

**Table 6: Belt Speeds for Standard Load Fixed Speed 90° 60 Hz Gearmotors on MPB Series Conveyors**

Gearmotors				Belt Speed	
Part Number	RPM	In lb	N-m	Ft/min	M/min
32M060HL4(vp)F(n)	29	226	25.5	20	6.0
32M040HL4(vp)F(n)	43	237	26.8	29	8.9
32M020HL4(vp)F(n)	86	142	16	59	17.9

(vp) = voltage and phase

(n) = Reversing Capability

11 = 115 V, 1-phase

N = No Reversing Capability

23 = 208 – 230/460 V, 3-phase

R = With Reversing Capability

**Table 7: Belt Speeds for Standard Load Variable Speed 90° DC Gearmotors on MPB Series Conveyors**

Gearmotors				Belt Speed	
Part Number	Max RPM	In-lb	N-m	Ft/min	M/min
32M060HLD3DEN	42	198	22.4	3.4–28	1.0–8.6
32M040HLD3DEN	63	163	18.4	5.1–42	1.6–12.9
32M020HLD3DEN	125	98	11.1	10–85	3–26
32M010HLD3DEN	250	54	6.1	20–170*	6–52*

\* = Cleated and Sidewall Cleated belts operate at a maximum of 150 ft/min (45.7 m/min)

## NOTE

*For belt speed other than those listed, contact factory for details.*

## Required Tools

- Hex key wrenches:  
3 mm, 5 mm
- Large flat-blade screwdriver
- Torque wrench

## Mounting

<b>⚠ WARNING</b>

<p>Exposed moving parts can cause severe injury.</p> <p><b>LOCK OUT POWER</b> before removing guards or performing maintenance.</p>

<b>⚠ WARNING</b>

<p>MPB Series Conveyors are not reversible. Reversing creates pinch points which can cause severe injury.</p> <p><b>DO NOT REVERSE MPB SERIES CONVEYORS.</b></p>

## Installation Component List:

F	Drive Assembly
G	M6 Socket Head Screws (2x)
H	Hex Shaft (2100 & 4100 Flat Belt Conveyor Only)

1. Typical components (Figure 2)

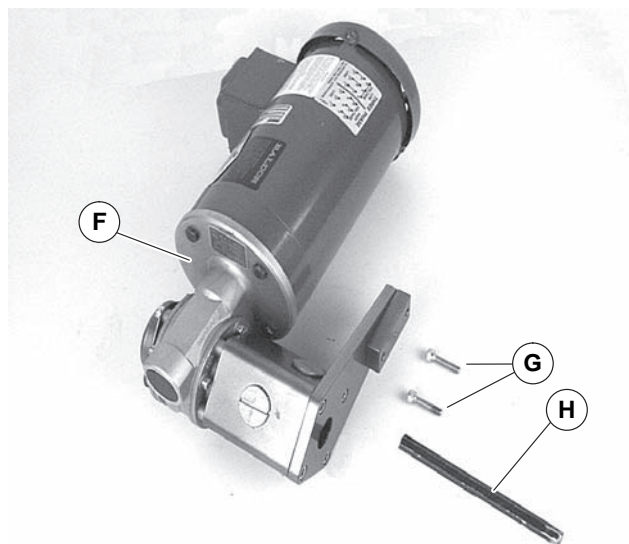

Figure 2

<b>NOTE</b>
<p>Flat belt mounting package shown above (Figure 2), cleated belt mounting package similar.</p>

<b>NOTE</b>
<p>Gearmotor may be operated in positions 1, 2, 3 or 4 (Figure 3).</p>

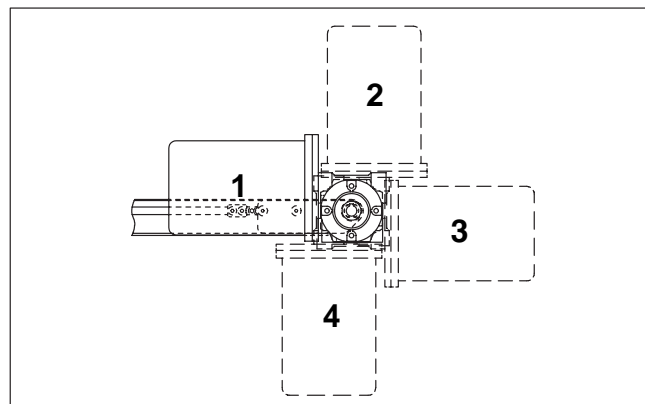

Figure 3

# Installation

- If required, change gearmotor position by removing four (4) screws (Figure 4, item I). Rotate gearmotor to other position (Figure 3) and replace screws (I). Tighten to 100 in-lb (12 N-m).



**Figure 4**

## For 4100 and 2100 Flat Belt Conveyors

### IMPORTANT

*On 4 inch (95 mm) and wider conveyors, the hex broach is offset from center towards the drive side for hex shaft engagement.*

- The figures below show gearmotor mounting for 4100 and 2100 series conveyors.

Gearmotor and Drive Plate are mounted to Spacer Plate

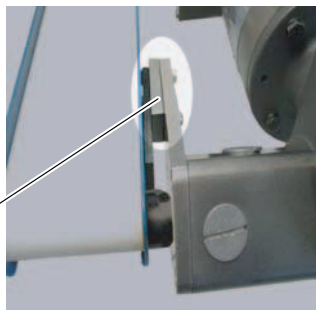

**4100 Series**  
**Figure 5**

Gearmotor and Drive Plate are mounted to Spacer Plate

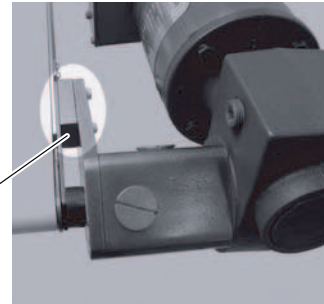

**2100 Series**  
**Figure 6**

- Locate drive mounting position and remove two (2) screws (Figure 7, item J).

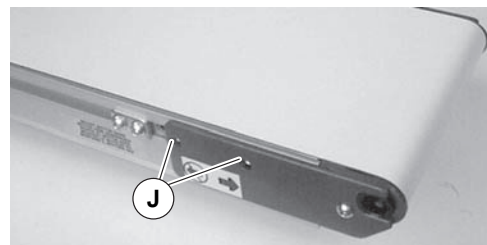

**Figure 7**

- Remove inspection plugs (Figure 8, item K).

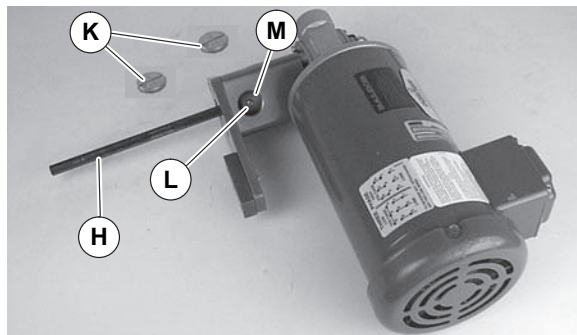
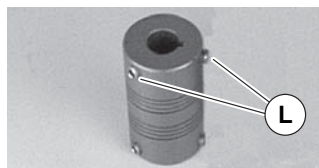

**Figure 8**



- Insert hex shaft (Figure 9, item H) into coupling.

<b>⚠ WARNING</b>

Exposed moving parts can cause severe injury. <b>KEEP HANDS CLEAR OF DRIVE WHILE JOGGING MOTOR.</b>
<b>NOTE</b>
<i>Coupling has two (2) set screws (Figure 9, item L).</i>

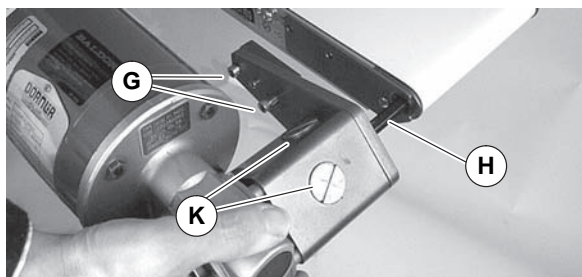

**Figure 9**

- Jog motor and rotate coupling to align set screw (Figure 8, item L) with access hole (M). Tighten to 32 in-lb (3.7 N-m). Repeat for second set screw.

<b>⚠ WARNING</b>

Exposed moving parts can cause severe injury. <b>LOCK OUT POWER AFTER JOGGING MOTOR.</b>

- Replace inspection plugs (Figure 10, item K). Insert hex shaft (H) into drive pulley hex bushing and slide drive against conveyor. Install two (2) screws (G). Tighten to 80 in-lb (9 N-m).



**Figure 10**

## For 6200, 2200, MPB and 2100 Cleated Belt Conveyors

<b>⚠ WARNING</b>

Drive shaft keyway may be sharp. <b>HANDLE WITH CARE.</b>

- The figures below show gearmotor mounting for 6200, 2200 and MPB series conveyors.

Gearmotor and Drive Plate are mounted to Spacer Plate

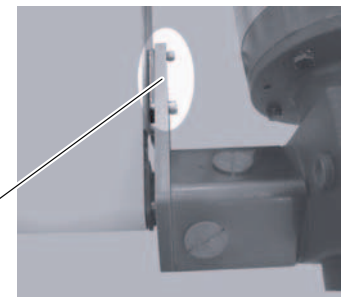

**6200 Series**

**Figure 11**

Gearmotor and Drive Plate are mounted to Head Plate

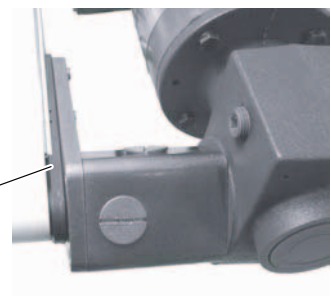

**2200 Series**

**Figure 12**

Gearmotor and Drive Plate are mounted to Head Plate

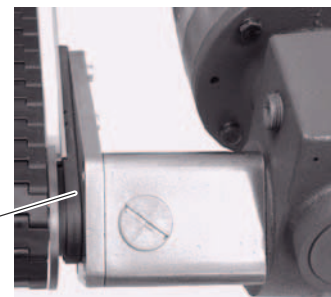

**MPB Series**

**Figure 13**

# Installation

## NOTE

6200 conveyor shown, 2200 and MPB cleated belt conveyors similar.

2. Locate drive output shaft. Remove two screws (Figure 14, item J). Install key (N).

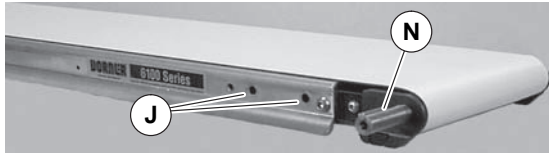

Figure 14

3. Remove inspection plugs (Figure 15, item K).

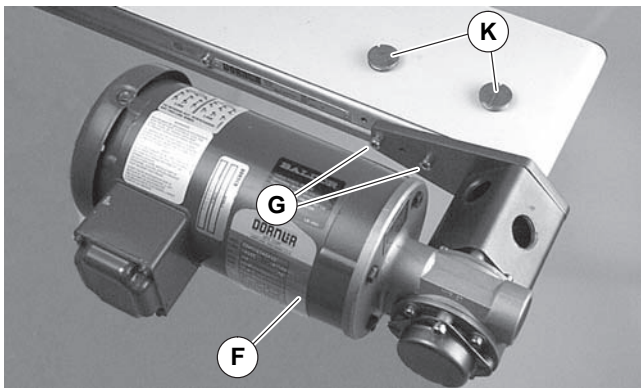

Figure 15

4. Slide coupling over drive output shaft and install drive assembly (Figure 15, item F) with screws (G). Tighten to 80 in-lb (9 N-m).

## WARNING



Exposed moving parts can cause severe injury.  
KEEP HANDS CLEAR OF DRIVE WHILE JOGGING MOTOR.

## NOTE

Coupling has two (2) set screws (Figure 9, item L).

5. Jog motor and rotate coupling to align set screw (Figure 16, item L) with access hole (M). Tighten to 32 in-lb (3.7 N-m). Repeat for second set screw.

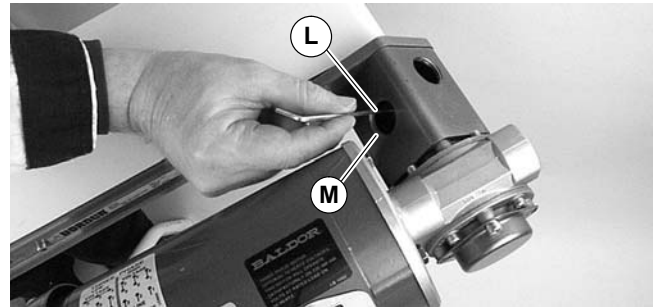

Figure 16

## WARNING



Exposed moving parts can cause severe injury.  
LOCK OUT POWER AFTER JOGGING MOTOR.

6. Replace inspection plugs. (Figure 15, item K).

# Preventive Maintenance and Adjustment

## Required Tools

- Hex key wrenches:  
2.5 mm, 3 mm, 5 mm
- Large flat-blade screwdriver
- Adjustable wrench (for hexagon head screws)
- External snap ring pliers
- Torque wrench

## Gear Reducer Replacement

<b>⚠ WARNING</b>

<b>Exposed moving parts can cause severe injury.</b> <b>LOCK OUT POWER</b> before removing guards or performing maintenance.

1. Remove inspection plugs (Figure 15, item K).

<b>⚠ WARNING</b>

<b>Exposed moving parts can cause severe injury.</b> <b>KEEP HANDS CLEAR OF DRIVE WHILE JOGGING MOTOR.</b>

<b>NOTE</b>
<i>Coupling has two (2) set screws (Figure 9, item L).</i>

2. Jog motor and rotate coupling to align set screw (Figure 16, item L) with access hole (M). Loosen set screw. Repeat for second set screw.
3. Remove two (2) screws (Figure 15, item G). Remove drive assembly (F).

4. Remove four (4) screws (Figure 17, item I) and remove mounting bracket & tube (O).

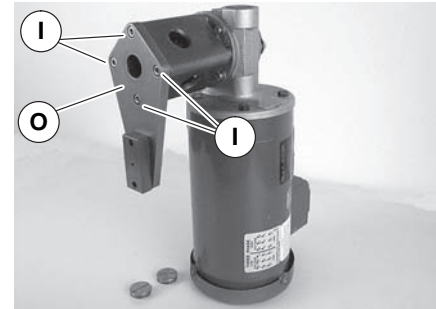

Figure 17

5. Loosen two (2) set screws (Figure 18, item L) and detach coupling (P) from gear reducer.

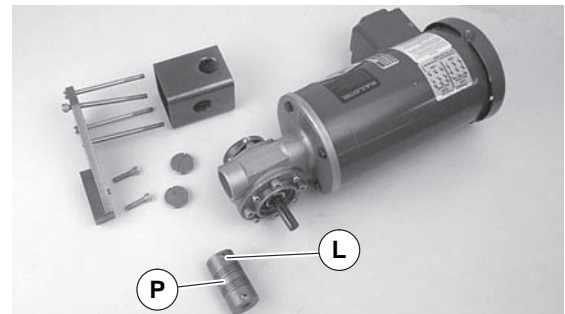

Figure 18

6. Remove four screws (Figure 19, item Q). Detach motor (R) from gear reducer (S). Retain shaft key (T).

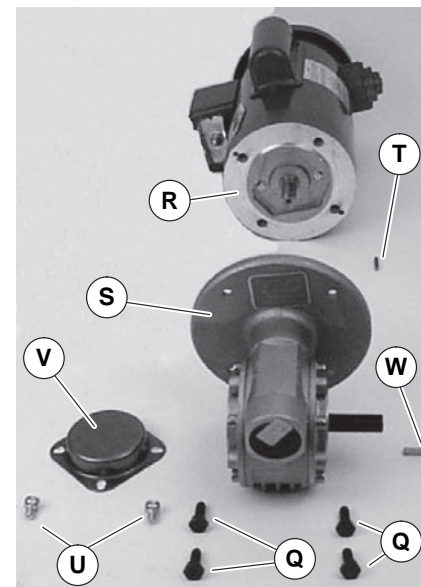

Figure 19

7. Remove two (2) screws (U) and detach output shaft cover (V).
8. Remove gear reducer output shaft key (W).

# Preventive Maintenance and Adjustment

9. Loosen six (6) set screws (Figure 20, item X). Remove drive shaft (Y) and key (Z).

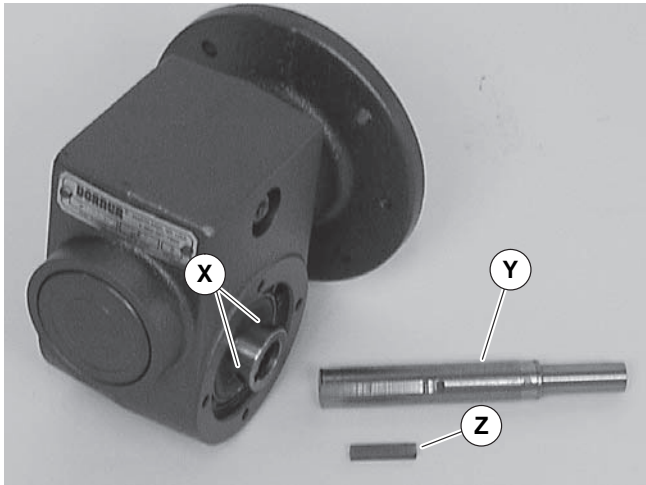

Figure 20

10. Apply grease (Figure 21, item AA) to shaft.

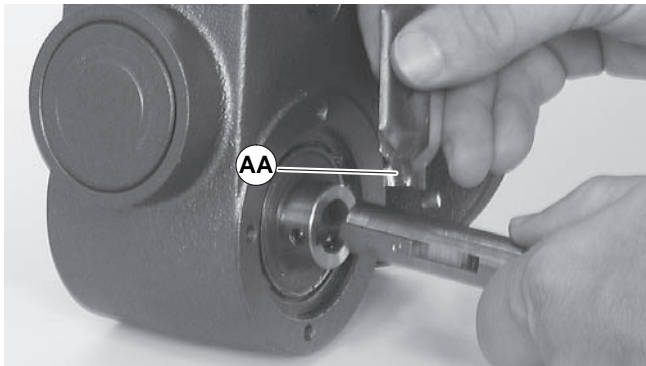

Figure 21

11. Replace the original shaft components into new gear reducer (see Figure 20).

## IMPORTANT

*Be extremely careful when coupling motor to gear reducer. Avoid misalignment and forcing the connection causing possible permanent gear reducer seal damage.*

12. With key (Figure 19, item T) in keyway, slide motor (R) and gear reducer (S) together. Install screws (Q) and tighten.
13. Attach coupling (Figure 18, item P) to gear reducer shaft. Tighten two set screws (L) to 32 in-lb (4.7 N-m).
14. Attach mounting bracket & tube (Figure 17, item O) to gearmotor. Tighten screws (I) to 103 in-lb (12 N-m).

15. Complete installation steps:

- See “4100 and 2100 Flat Belt Conveyors” section on page 8.
- See “6200 2200, MPB and 2100 Cleated Belt Conveyors” section on page 9.

## Motor Replacement

### ⚠ WARNING



Exposed moving parts can cause severe injury.  
**LOCK OUT POWER** before removing guards or performing maintenance.

### ⚠ DANGER



Hazardous voltage will cause severe injury or death.  
**LOCKOUT POWER BEFORE** before wiring.

1. For single phase motor, unplug power cord from outlet.
2. For three phase motor:
  - a. Loosen terminal box screws (Figure 22, item AB) and remove cover (AC).

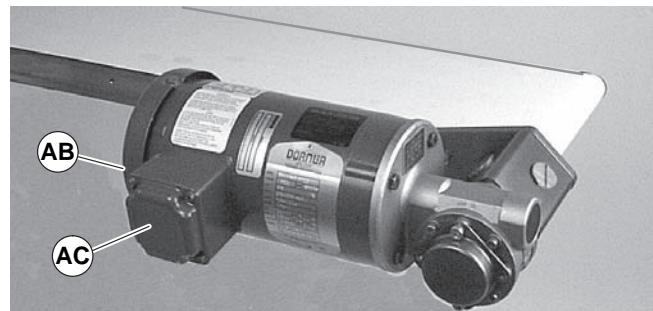
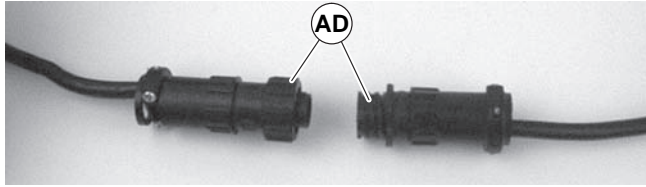

Figure 22

- a. Record wire colors connecting to wires 1, 2 and 3. Loosen wire nuts and remove wires 1, 2 and 3.
- c. Loosen cord grip and remove cord.

# Preventive Maintenance and Adjustment

3. For DC variable speed motor, unplug motor cord at disconnect (Figure 23, item AD).



**Figure 23**

4. Remove four screws (Figure 24, item Q). Detach motor (R) from gear reducer (S). Retain motor output shaft key (T).

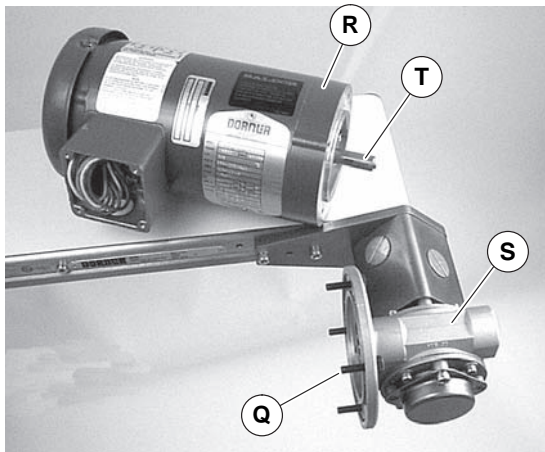

**Figure 24**

5. With key (Figure 25, item T) in keyway, slide motor and gear reducer together. Install screws (Q) and tighten.

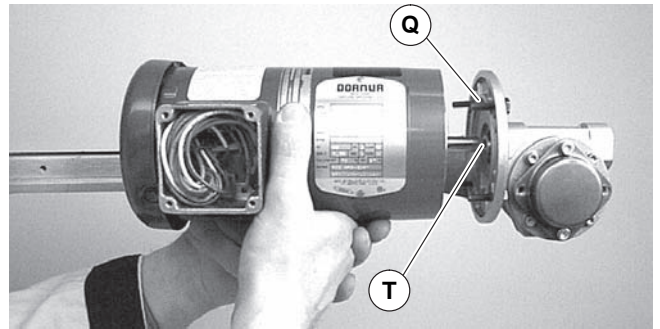

**Figure 25**

6. Replace wiring:

- For a single phase motor, reverse step 1 on page 12.
- For a three phase motor, reverse step 2, on page 12.
- For a DC variable speed motor, reverse step 3 on page 13.

## IMPORTANT

*Be extremely careful when coupling motor to gear reducer. Avoid misalignment and forcing the connection causing possible permanent gear reducer seal damage.*

# Service Parts

## NOTE

For replacement parts other than those shown in this section, contact an authorized *Dorner Service Center* or the factory. Key Service Parts and Kits are identified by the Performance Parts Kits logo . Dorner recommends keeping these parts on hand.

## Side Mount Drive Package for 90° 60 Hz Gearmotors

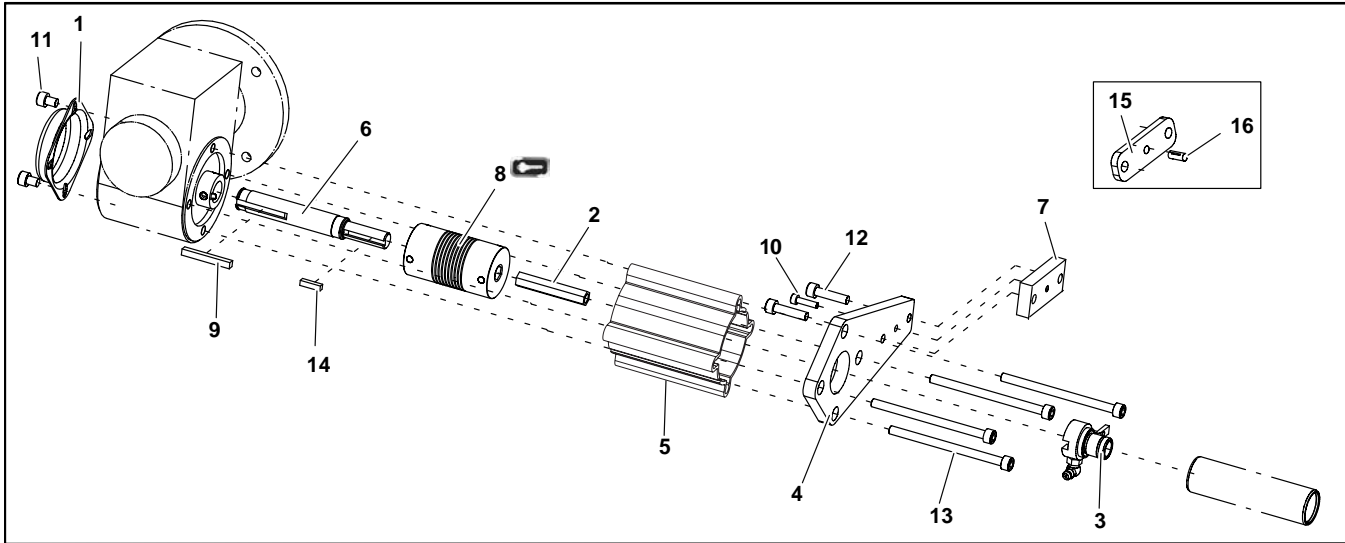

Item	Part Number	Description
1	300139	Drive-Bearing Shaft Cover
2	616301	Outboard Drive Shaft 1" (25mm) Wide
	616302	Outboard Drive Shaft 2" (51mm) Wide
	616303	Outboard Drive Shaft 3" (76mm) Wide
	616304	Outboard Drive Shaft 4" (102mm) Wide
	616305	Outboard Drive Shaft 5" (127mm) Wide
	616306	Outboard Drive Shaft 6" (152mm) Wide
	616308	Outboard Drive Shaft 8" (203mm) Wide
	616310	Outboard Drive Shaft 10" (254mm) Wide
	616312	Outboard Drive Shaft 12" (305mm) Wide
	203968	Outboard Drive Shaft 18" (457mm) Wide (2100 Conveyors)
203971	Outboard Drive Shaft 21" (533mm) Wide (2100 Conveyors)	
203974	Outboard Drive Shaft 24" (610mm) Wide (2100 Conveyors)	
3	618898	Retaining Sleeve 3" – 12" (76mm – 305mm) (4100 Conveyors)
	200399M	Retaining Sleeve (2100 Conveyors)
	200223M	Retaining Sleeve (2100 Cleated Conveyors)
4	450266M	Side Drive Plate (4100 & 6200 Conveyors)
	242525M	Side Drive Plate (2200 & MPB Conveyors)
5	450475	Side Drive Spacer Guard (x2)
6	450444M	Output Shaft
7	697863M	Spacer Plate (4100)
	203975M	Spacer Plate (2100)

Item	Part Number	Description
8	807-996	Flex Coupling (for 2100 & 4100)
	807-995	Flex Coupling
9	912-084	Square Key, 0.188 x 1.50
10	920416M	Socket Head Screw, M4 x 16mm
11	920608M	Socket Head Screw, M6 x 8mm
12	920614M	Socket Head Screw for 1-2" (25-51mm) wide 4100 Conveyors M6 x 14mm
	920625M	Socket Head Screw, M6 x 25mm
	920630M	Socket Head Screw, for 6200 Conveyors M6 x 30mm
	920635M	Socket Head Screw, for 2100 Conveyors M6 x 35mm
13	920690M	Socket Head Screw, M6 x 90mm
14	980416M	Square Key, 4mm x 16mm
15	450027M	Spacer Plate (6200)
16	807-952	Groove Pin (6200)

## 4100 Adapter Components

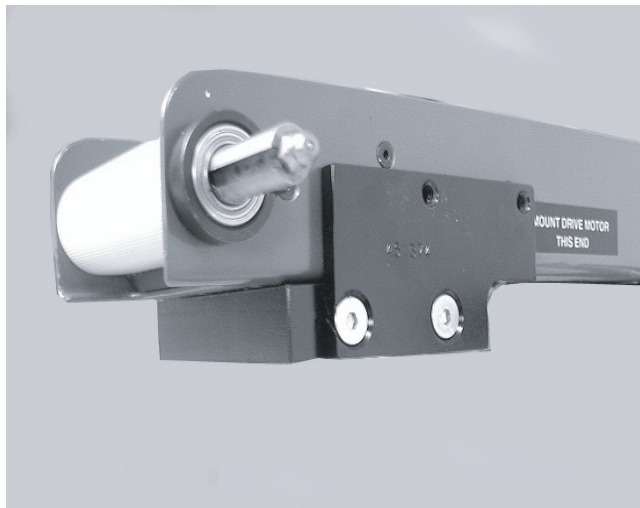
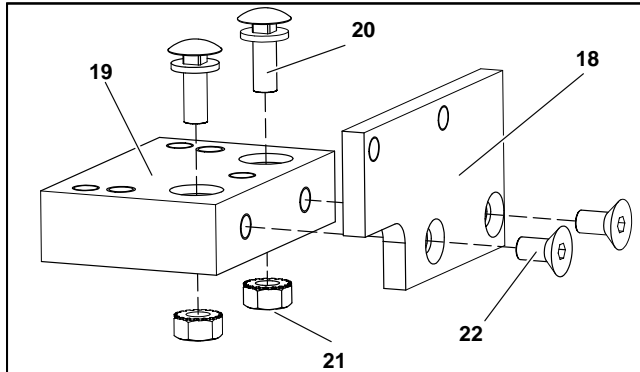

Adapter package attached to a 4100 series conveyor.

## Gearmotors

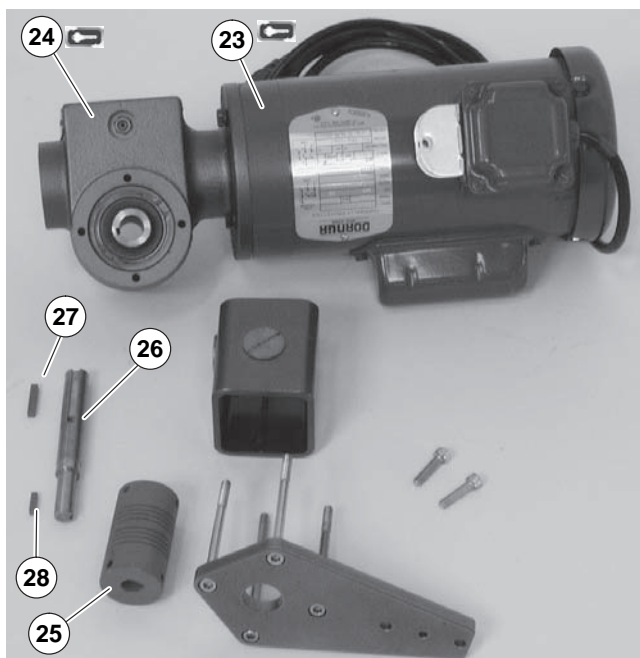

Item	Part Number	Description
18	450374	Drive Adaptor Plate
19	609486	Mounting Block 1" (25mm)
	609487	Mounting Block 2" (51mm)
	609488	Mounting Block 3" (76mm)
	609479	Mounting Block 4" (102mm)
	609480	Mounting Block 5" (127mm)
	609481	Mounting Block 6" (152mm)
	609482	Mounting Block 7" (178mm)
	609483	Mounting Block 8" (203mm)
	609484	Mounting Block 10" (254mm)
609485	Mounting Block 12" (305mm)	
20	613602P	Bolt/Flat Washer Assembly
21	910-126	Hex Nut with Lock Washer
22	930612M	Flat Head Screw M6 x 12mm
23	62MS411FN	Motor, 0.25 Hp (0.19 Kw) 115/230 Volts, 60 Hz, 1-Phase
	62MS411FR	Motor, 0.25 Hp (0.19 Kw) 115/230 Volts, 60 Hz, 1-Phase with Reversing
	62MS423	Motor, 0.25 Hp (0.19 Kw) 208-230/460 Volts, 60 Hz, 3-Phase
	62MSD3DEN	Motor, 0.25 Hp (0.19 Kw) 130 Volts DC
	32MS423EI*	Motor, 0.25 Hp (0.19 Kw) 230/460 Volts DC, 60 Hz, 3-Phase Variable Frequency/Indexing
	24	32M005HL
32M010HL		Gear Reducer, 10:1, 42CZ
32M020HL		Gear Reducer, 20:1, 42CZ
32M040HL		Gear Reducer, 40:1, 42CZ
32M060HL		Gear Reducer, 60:1, 42CZ
32M005HS		Gear Reducer, 5:1, 56C (for motors with part numbers ending with EI or EN only)
32M010HS		Gear Reducer, 10:1, 56C (for motors with part numbers ending with EI or EN only)
32M020HS		Gear Reducer, 20:1, 56C (for motors with part numbers ending with EI or EN only)
32M040HS		Gear Reducer, 40:1, 56C (for motors with part numbers ending with EI or EN only)
32M060HS		Gear Reducer, 60:1, 56C (for motors with part numbers ending with EI or EN only)
25	807-996	Coupling for 2100, 2200, 4100 and MPB Flat Belt Conveyor
	807-995	Coupling for 2100 Cleated Belt Conveyor
	807-995	Coupling for 6100 Conveyor
26	450444M	Gear Reducer Shaft
27	912-084	Key, Square, 0.188" x 1.5" L
28	980416M	Key, Square, 4mm x 16mm L

\*This motor is rated at 1/2 hp when running as a fixed speed motor at 60 hz or when used as an indexing motor. When used as a variable speed motor, the HP rating is reduced to 1/4 hp.

# Return Policy

Returns must have prior written factory authorization or they will not be accepted. Items that are returned to Dorner without authorization will not be credited nor returned to the original sender. When calling for authorization, please have the following information ready for the Dorner factory representative or your local distributor:

1. Name and address of customer.
2. Dorner part number(s) of item(s) being returned.
3. Reason for return.
4. Customer's original order number used when ordering the item(s).
5. Dorner or distributor invoice number (if available, part serial number).

A representative will discuss action to be taken on the returned items and provide a Returned Goods Authorization (RMA) number for reference. RMA will automatically close 30 days after being issued. To get credit, items must be new and undamaged. There will be a return charge on all items returned for credit, where Dorner was not at fault. It is the customer's responsibility to prevent damage during return shipping. Damaged or modified items will not be accepted. The customer is responsible for return freight.

## Conveyors and conveyor accessories

Standard catalog conveyors	30%
MPB, 7200, 7300 Series, cleated and specialty belt	50%
AquaGard & AquaPruf Series conveyors	non-returnable items
Engineered to order products	case by case
Drives and accessories	30%
Sanitary stand supports	non-returnable items

## Parts

Standard stock parts	30%
Plastic chain, cleated and specialty belts	non-returnable items

Returns will not be accepted after 60 days from original invoice date. The return charge covers inspection, cleaning, disassembly, disposal and reissuing of components to inventory. If a replacement is needed prior to evaluation of returned item, a purchase order must be issued. Credit (if any) is issued only after return and evaluation is complete.

Dorner has representatives throughout the world. Contact Dorner for the name of your local representative. Our Customer Service Team will gladly help with your questions on Dorner products.

For a copy of Dorner's Warranty, contact factory, distributor, service center or visit our website at [www.dorner.com](http://www.dorner.com).

For replacement parts, contact an authorized Dorner Service Center or the factory.



Dorner Mfg. Corp. reserves the right to change or discontinue products without notice. All products and services are covered in accordance with our standard warranty. All rights reserved. © Dorner Mfg. Corp. 2010

## DORNER MFG. CORP.

975 Cottonwood Ave., PO Box 20  
Hartland, WI 53029-0020 USA  
TEL 1-800-397-8664 (USA)  
FAX 1-800-369-2440 (USA)  
Internet: [www.dorner.com](http://www.dorner.com)

Outside the USA:  
TEL 1-262-367-7600  
FAX 1-262-367-5827