

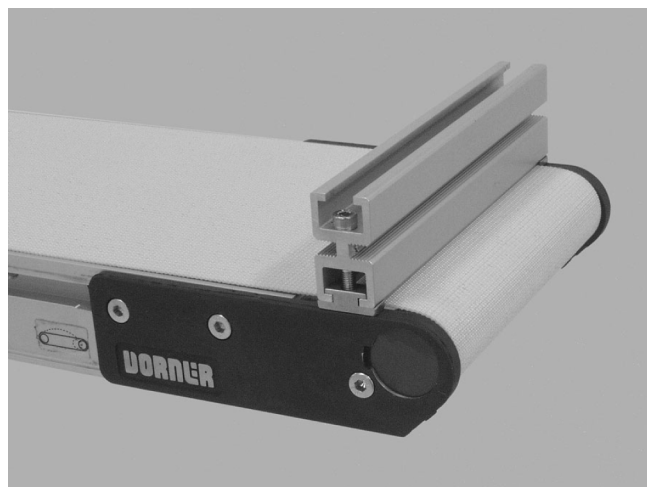

End Stop for 2200 & MPB Series Conveyors

Installation, Maintenance & Parts Manual



DORNER MFG. CORP.
P.O. Box 20 • 975 Cottonwood Ave.
Hartland, WI 53029-0020 USA

INSIDE THE USA
TEL: 1-800-397-8664
FAX: 1-800-369-2440

OUTSIDE THE USA
TEL: 262-367-7600
FAX: 262-367-5827

For other service manuals visit our website at:
www.dorner.com/service_manuals.asp

Table of Contents

Introduction	2	Mounting When Ordered Without Conveyor.....	5
Warnings - General Safety	3	Service Parts.....	6
Installation	4	Notes	7
Required Tools.....	4	Return Policy.....	8
Mounting When Ordered With Conveyor	4		

Introduction

IMPORTANT

<i>Some illustrations may show guards removed. DO NOT operate equipment without guards.</i>

Dorner 2200 Series conveyors are covered by Patent No. 5,174,435, 5,131,529 and corresponding patents and patent applications in other countries.

Dorner's Limited Warranty applies.

Dorner reserves the right to make changes at any time without notice or obligation.

Upon receipt of shipment:

- Compare shipment with packing slip. Contact factory regarding discrepancies.
- Inspect packages for shipping damage. Contact carrier regarding damage.
- Accessories may be shipped loose. See accessory instructions for installation.

Warnings - General Safety

WARNING

The safety alert symbol, black triangle with white exclamation, is used to alert you to potential personal injury hazards.

DANGER



Climbing, sitting, walking or riding on conveyor will cause severe injury.
KEEP OFF CONVEYORS.

DANGER



DO NOT OPERATE CONVEYORS IN AN EXPLOSIVE ENVIRONMENT.

WARNING



Exposed moving parts can cause severe injury.
LOCK OUT POWER before removing guards or performing maintenance.

WARNING



Dorner cannot control the physical installation and application of conveyors. Taking protective measures is the responsibility of the user.
When conveyors are used in conjunction with other equipment or as part of a multiple conveyor system, **CHECK FOR POTENTIAL PINCH POINTS** and other mechanical hazards before system start-up.

WARNING



Exposed moving parts can cause severe injury.
REPLACE ALL GUARDS BEFORE RUNNING CONVEYOR.

DANGER



Use of end stop with high friction conveyor belt will cause severe injury.
DO NOT use end stop with /03, /08, /55, /62, /64, or other high friction belts.

Installation

Required Tools

- Hex key wrenches:
2.5 mm, 4 mm, 5 mm
- Torque wrench

Mounting When Ordered With Conveyor

⚠ DANGER

Use of end stop with high friction conveyor belt will cause severe injury. DO NOT use end stop with /03, /08, /55, /62, /64, or other high friction belts.

⚠ WARNING

Exposed moving parts can cause severe injury.
LOCK OUT POWER before removing guards or performing maintenance.

NOTE
<i>End stop is designed for parts at least 1/4" thick or larger.</i>

Installation Component List:

A	End Stop
B	Spacer (2x)
C	M5 x 40 Socket Head Screw (2x) 2200 Series M5 x 50 Socket Head Screw (2x) MPB Series

1. Gather components (Figure 1)

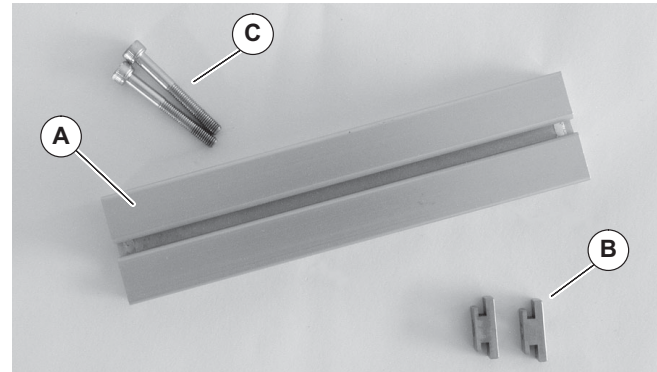

Figure 1

2. Insert spacer (Figure 2, item B) in both ends of end stop (A).

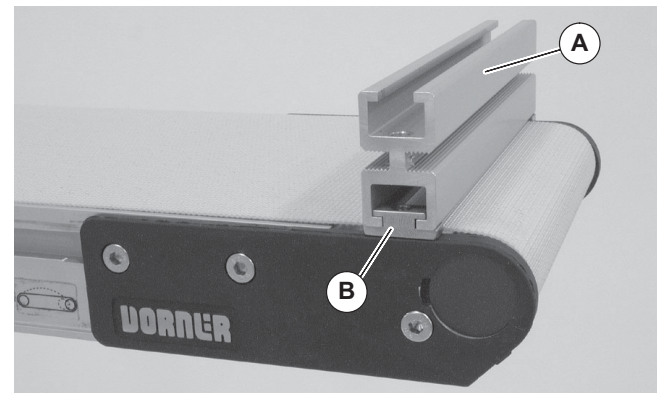

Figure 2

3. Install end stop with spacers (Figure 3, item A) on end of conveyor with M5 screws (CC). Tighten screws to 30 in-lb (3.4 Nm).

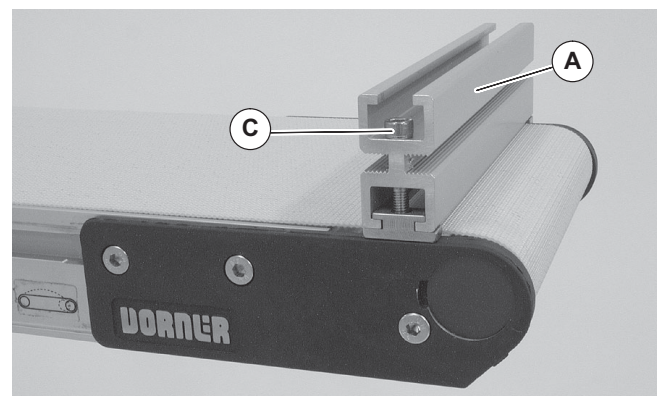



Figure 3

Mounting When Ordered Without Conveyor

⚠ DANGER

<p>Use of end stop with high friction conveyor belt will cause severe injury. DO NOT use end stop with /03, /08, /55, /62, /64, or other high friction belts.</p>

⚠ WARNING

<p>Exposed moving parts can cause severe injury. LOCK OUT POWER before removing guards or performing maintenance.</p>

Installation Component List:

A	End Stop
B	Spacer (2x)
C	M5 x 40 Socket Head Screw (2x) 2200 Series M5 x 50 Socket Head Screw (2x) MPB Series
D	Headplate (LH)
E	Headplate (RH)

1. Gather components (Figure 4)

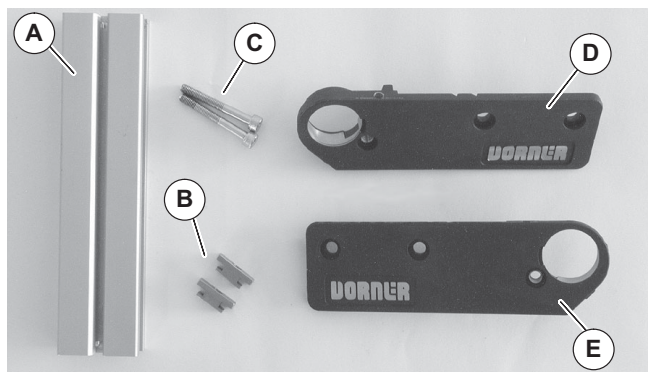

Figure 4

2. Remove conveyor end pulley. See “Pulley Removal” in the “2200 Series End Drive Conveyors” manual, part number 851–452.
3. Remove bearings from conveyor headplates and install them into new headplates (Figure 4, item D & E). See “Bearing Removal and Replacement” in the “2200 Series End Drive Conveyors” manual, part number 851–452.

4. Replace end pulley and new headplates. See “Pulley Replacement” in the “2200 Series End Drive Conveyors” manual, part number 851–452.
5. Install conveyor belt. See belt installation section in the “2200 Series End Drive Conveyors” manual, part number 851–452.
6. Tension the conveyor belt. See “Conveyor Belt Tensioning” in the “2200 End Drive Conveyors” manual, part number 851–452.
7. Insert spacer (Figure 5, item B) in both ends of end stop (A).

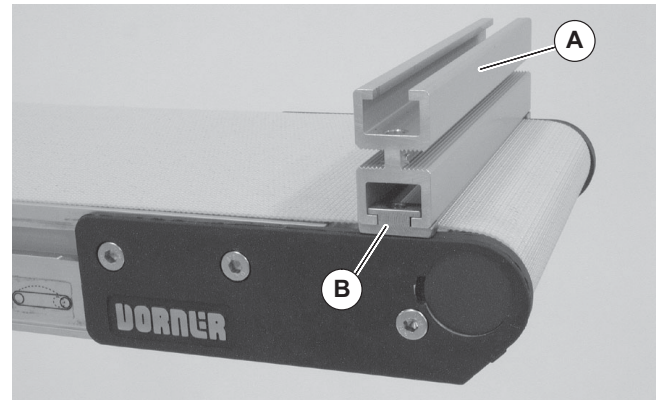

Figure 5

8. Install end stop with spacers (Figure 6, item A) on end of conveyor with M5 screws (C). Tighten screws to 30 in-lb (7 Nm).

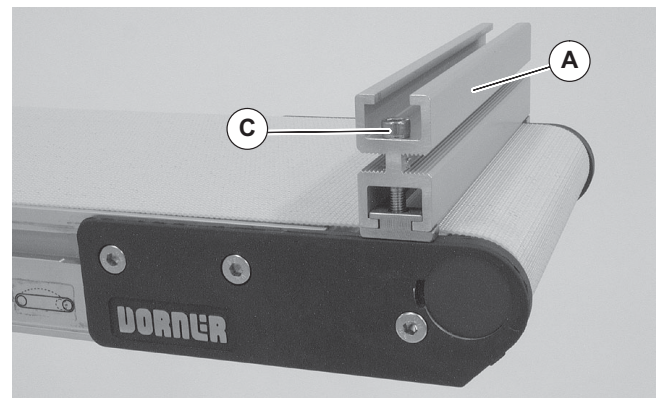

Figure 6

Service Parts

NOTE

For replacement parts other than those shown on this page, contact an authorized Dorner Service Center or the factory.

Item	Part No.	Part Description
1	240335	Headplate, Left Hand
2	240336	Headplate, Right Hand
3	243002	End Stop, 2" (51mm)
	243003	End Stop, 3" (76mm)
	243004	End Stop, 4" (102mm)
	243005	End Stop, 5" (127mm)
	243006	End Stop, 6" (152mm)
	243008	End Stop, 8" (203mm)
	243010	End Stop, 10" (254mm)
	243012	End Stop, 12" (305mm)
	243018	End Stop, 18" (457mm)
	243021	End Stop, 21" (533mm)
243024	End Stop, 24" (610mm)	
4	243025	Stand-off Spacer (2200 Series)
	245855	Stand-off Spacer (MPB Series)
5	920540M	M5 x 40mm Socket Head Screw (2200 Series)
	920550M	M5 x 50mm Socket Head Screw (MPB Series)

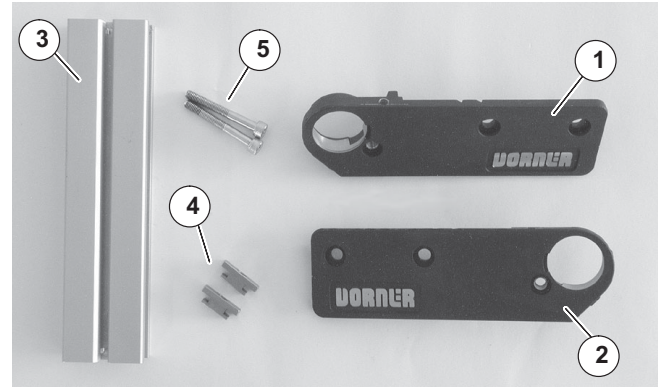

Figure 7

Return Policy

Returns must have prior written factory authorization or they will not be accepted. Items that are returned to Dorner without authorization will not be credited nor returned to the original sender. When calling for authorization, please have the following information ready for the Dorner factory representative or your local distributor:

1. Name and address of customer.
2. Dorner part number(s) of item(s) being returned.
3. Reason for return.
4. Customer's original order number used when ordering the item(s).
5. Dorner or distributor invoice number.

A representative will discuss action to be taken on the returned items and provide a Returned Goods Authorization number for reference.

There will be a return charge on all new undamaged items returned for credit where Dorner was not at fault. Dorner is not responsible for return freight on such items.

Conveyors and conveyor accessories	
Standard catalog conveyors	30%
MPB Series, cleated and specialty belt conveyors	50%
7400 & 7600 Series conveyors	non-returnable items
Engineered special products	case by case
Drives and accessories	30%
Sanitary stand supports	non-returnable items

Parts	
Standard stock parts	30%
MPB, cleated and specialty belts	non-returnable items

Returns will not be accepted after 60 days from original invoice date.

The return charge covers inspection, cleaning, disassembly, disposal and reissuing of components to inventory.

If a replacement is needed prior to evaluation of returned item, a purchase order must be issued. Credit (if any) is issued only after return and evaluation is complete.

Dorner has representatives throughout the world. Contact Dorner for the name of your local representative. Our Technical Sales, Catalog Sales and Service Teams will gladly help with your questions on Dorner products.

For a copy of Dorner's Warranty, contact factory, distributor, service center or visit our website at www.dorner.com.

For replacement parts, contact an authorized Dorner Service Center or the factory.



Dorner Mfg. Corp. reserves the right to change or discontinue products without notice. All products and services are covered in accordance with our standard warranty. All rights reserved. © Dorner Mfg. Corp. 2006

DORNER MFG. CORP.

975 Cottonwood Ave., PO Box 20
Hartland, WI 53029-0020 USA
USA
TEL 1-800-397-8664 (USA)
FAX 1-800-369-2440 (USA)
Internet: www.dorner.com

Outside the USA:
TEL 1-262-367-7600
FAX 1-262-367-5827