

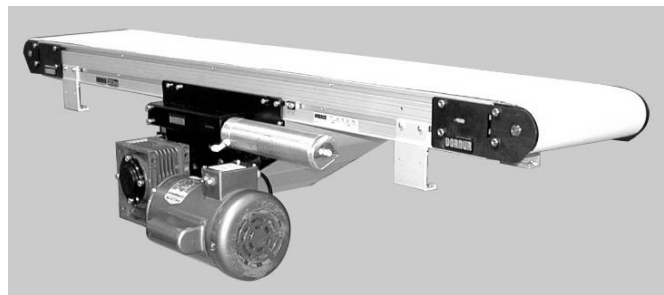

3200 Series Center Drive Flat Belt Conveyors

Installation, Maintenance & Parts Manual



DORNER MFG. CORP.
P.O. Box 20 • 975 Cottonwood Ave.
Hartland, WI 53029-0020 USA

INSIDE THE USA
TEL: 1-800-397-8664
FAX: 1-800-369-2440

OUTSIDE THE USA
TEL: 262-367-7600
FAX: 262-367-5827

For other service manuals visit our website at:
www.dorner.com/service_manuals.asp

Table of Contents

Introduction	2	B – Transfer Tail Pulley Removal.....	20
Warnings – General Safety	3	Center Drive Pulleys Removal	21
Product Description	4	A – Tensioner Pulley Removal.....	21
Specifications	4	B – Idler Pulley Removal	22
Installation	7	C – Drive Pulley Removal.....	24
Required Tools.....	7	Bearing Replacement	25
Recommended Installation Sequence	7	A – Idler Bearing Replacement	26
Conveyors Up to 13 ft (3962 mm).....	7	B – Drive Bearing Removal and Replacement.....	26
Mounting Brackets.....	8	Drive Side Bearing.....	26
Return Rollers	8	Idler Side Bearing.....	27
4–6” (51–152 mm) Wide Conveyors.....	8	C – Transfer Tail Bearing Replacement	27
8–48” (203–1219 mm) Wide Conveyors.....	8	Pulley Replacement.....	27
Gearmotor Installation	9	Idler Pulley.....	27
Required Tools	9	Drive Pulley	27
Mounting	9	Transfer Tail Pulley	27
Preventive Maintenance and Adjustment	11	Service Parts.....	28
Required Tools.....	11	Center Drive Assembly	28
Standard Tools.....	11	Center Drive Manual Tensioner	30
Checklist	11	Center Drive 90° Industrial Gearmotors.....	31
Lubrication.....	11	Transfer Tail Assembly	32
Maintaining Conveyor Belt	11	Idler End Assembly	33
Troubleshooting	11	Frame Assembly.....	34
Cleaning	11	Bed Plate and Frame Formulas	35
Conveyor Belt Replacement.....	11	–04 3” (76 mm) Aluminum Side.....	36
Conveyor Belt Replacement Sequence	11	–05 1.5” (38 mm) Aluminum Side.....	37
Belt Removal for Conveyor Without Stands.....	12	–07 Low to Side Wiper	38
Belt Removal for Conveyor With Stands.....	13	–09 Low to High Side	39
Belt Installation for Conveyor without Stands.....	14	–10.5” (13 mm) Extruded Plastic.....	40
Belt Installation for Conveyor with Stands	14	–13 Adjustable Guiding	41
Conveyor Belt Tensioning	15	Flared Side Guiding.....	42
A - With Pneumatic Tensioning.....	15	Flat Belt Mounting Brackets	43
B - With Manual Tensioning.....	16	Connecting Assembly without Stand Mount.....	43
Conveyor Belt Tracking.....	16	Flat Belt Connecting Assembly with Stand Mount ...	44
V-Guided Belts.....	16	4” (102 mm) to 6” (152 mm) Flat Belt Return Roller	44
Non V-Guided Belts.....	16	8” (203 mm) to 48” (1219 mm)	
Center Drive Module Tracking.....	17	Flat Belt Return Roller.....	45
V-Guided Belts.....	17	Conveyor Belt Part Number Configuration.....	46
Non V-Guided Belts.....	17	Flat Belt Part Number Configuration	46
End Pulley Removal	18	Notes	47
A – Idler Pulley Removal	19	Return Policy.....	48

Introduction

IMPORTANT

Some illustrations may show guards removed. DO NOT operate equipment without guards.

Upon receipt of shipment:

- Compare shipment with packing slip. Contact factory regarding discrepancies.
- Inspect packages for shipping damage. Contact carrier regarding damage.
- Accessories may be shipped loose. See accessory instructions for installation.

Dorner’s Limited Warranty applies.

Dorner 3200 series conveyors are covered by Patent Numbers 5,156,260, 6,871,737B2, 6,910,571B1, 6,971,509B2, and corresponding patents and patent applications in other countries.

Dorner reserves the right to make changes at any time without notice or obligation.

Dorner has convenient, pre-configured kits of Key Service Parts for all conveyor products. These time saving kits are easy to order, designed for fast installation, and guarantee you will have what you need when you need it. Key Parts and Kits are marked in the Service Parts section of this manual with the Performance Parts Kits logo .

Warnings – General Safety

WARNING

The safety alert symbol, black triangle with white exclamation, is used to alert you to potential personal injury hazards.

DANGER



Climbing, sitting, walking or riding on conveyor will cause severe injury.
KEEP OFF CONVEYORS.

WARNING



Gearmotors may be HOT.
DO NOT TOUCH Gearmotors.

DANGER



DO NOT OPERATE CONVEYORS IN AN EXPLOSIVE ENVIRONMENT.

WARNING



Exposed moving parts can cause severe injury.
LOCK OUT POWER before removing guards or performing maintenance.

WARNING



Exposed moving parts can cause severe injury.
REMOVE COMPRESSED AIR SUPPLY before removing guards or performing maintenance.

WARNING



Dorner cannot control the physical installation and application of conveyors. Taking protective measures is the responsibility of the user.
When conveyors are used in conjunction with other equipment or as part of a multiple conveyor system, **CHECK FOR POTENTIAL PINCH POINTS** and other mechanical hazards before system start-up.

WARNING



Loosening stand height or angle adjustment screws may cause conveyor sections to drop down, causing severe injury.
SUPPORT CONVEYOR SECTIONS PRIOR TO LOOSENING STAND HEIGHT OR ANGLE ADJUSTMENT SCREWS.

Product Description

Refer to Figure 1 for typical conveyor components.

A	Conveyor
B	Gearmotor
C	Guiding & Accessories
D	Mounting Brackets
E	Support Stand
F	Variable Speed Controller
G	Center Drive Module
H	Idler End

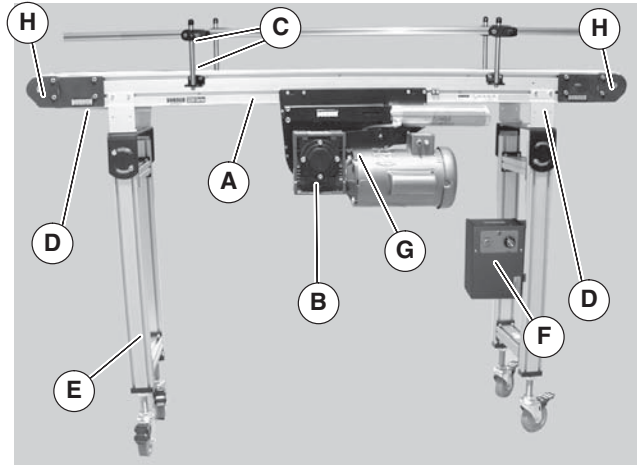

Figure 1

Specifications

Models:

Center Drive 3200 Series Conveyor

- 3 1 5 M WW LLLL / PP TT
- Belt Type* Profile*
 - Conveyor Length Reference
 - Conveyor Width Reference
 - Document Language, M = English
 - Idler Pulley Type: Pneumatic Tensioning
 - 5 = 3" idler pulleys at both ends
 - 6 = Two 1" pulleys at infeed
 - 7 = Two 1" pulleys at discharge
 - 8 = Two 1" pulleys at both ends
 - Idler Pulley Type: Manual Tensioning
 - 2 = 3" idler pulley at both ends
 - 3 = Two 1" pulleys at infeed
 - 4 = Two 1" pulleys at discharge
 - 9 = Two 1" pulleys at both ends
 - 1 = Flat belt with tracking cams and supports
 - 2 = Flat belt with V-guide tracking and supports
 - 3 = Flat belt with tracking cams
 - 4 = Flat belt with V-guide tracking

* See Ordering and Specifications Catalog for details.

Conveyor Supports:

Maximum Distances:

I = 36" (914 mm) (Infeed End)

J = 12 ft (3658 mm)

K = 36" (914 mm) (Discharge End)

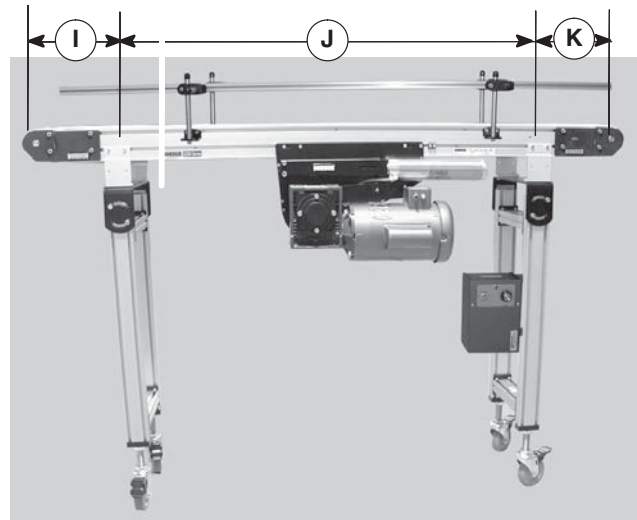
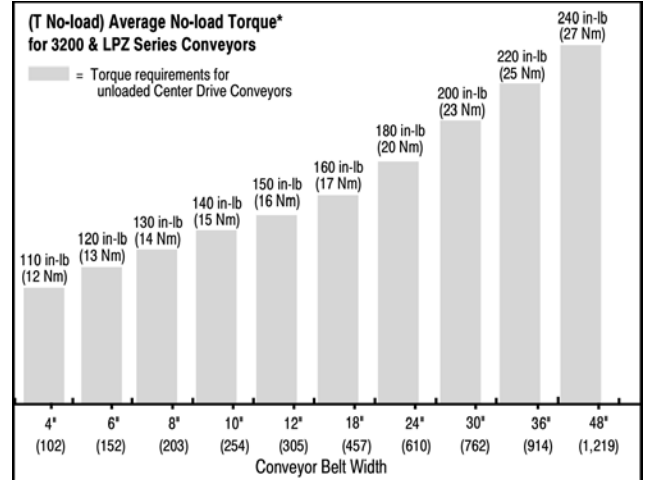
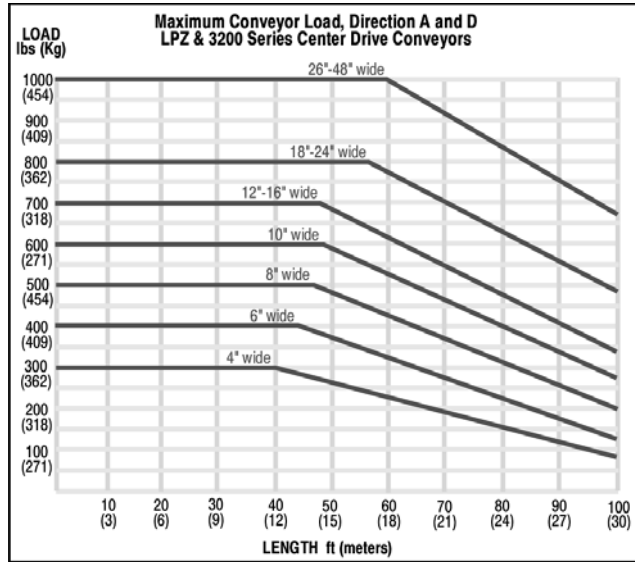

Figure 2

Specifications



Conveyor Width Reference (WW)	04	06	08	10	12	18	24	30	36	48
Conveyor Belt Width	3.75" (95mm)	6" (152mm)	8" (203mm)	10" (254mm)	12" (305mm)	18" (457mm)	24" (609mm)	30" (762mm)	36" (915mm)	48" (1220mm)
Conveyor Length Reference (LLL)	0300 to 9900 in 0001 increments									
Conveyor Length	18.8" (478 mm) per revolution of pulley									
Belt Travel	4 ft (1219mm) to 99 ft (30175mm) in 0.12" (0.31mm) increments									
Maximum Belt Speed*	600 ft/minute (183 m/minute)									
Belt Takeup	16" (407 mm) of Belt Takeup									

* See Ordering and Specifications Catalog for details.

NOTE

- Maximum conveyor loads based on:
- Non-accumulating product
 - Product moving towards gearmotor
 - Conveyor being mounted horizontal

Table 1: Belt Speeds for Variable Speed 90° VDC Gearmotors

Standard Load Gearmotors				Belt Speed	
Part Number	RPM	In-lb	N-m	Ft/min	M/min
32M100HHD9DEN	25	630	71	4.0–40.0	1.2–12.2
32M080HHD9DEN	31	575	65	5.0–50.0	1.5–15.2
32M060HHD9DEN	42	469	53	6.7–66.7	2.0–20.3

(vp) = voltage and phase

11 = 115 V, 1-phase

23 = 208 – 230/460 V, 3-phase

Specifications

Table 2: Belt Speeds for Fixed Speed 90° Gearmotors

Standard Load Gearmotors				Belt Speed	
Part Number	RPM	In-lb	N-m	Ft/min	M/min
32M100HHvpfN	17	913	103	27.6	8.4
32M080HHvpfN	22	833	94	34.5	10.5
32M060HHvpfN	29	680	77	46.0	14.0
32M050HHvpfN	35	1206	136	55.2	16.8
32M040HHvpfN	43	1023	116	69.0	21.0
32M030HHvpfN	58	1217	138	92.0	28.0
32M025HHvpfN	69	1069	121	110.4	33.7
32M020HHvpfN	86	1184	134	138.0	42.1
32M015HHvpfN	115	910	103	184.0	56.1
32M010HHvpfN	173	636	72	276.0	84.1
32M008HHvpfN	230	482	54	368.0	112.2

Table 3: Belt Speeds for Variable Speed 90° VFD Gearmotors

Standard Load Gearmotors				Belt Speed	
Part Number	RPM	In-lb	N-m	Ft/min	M/min
32M100HHvpfN	17	913	103	2.8–27.6	0.8–8.4
32M080HHvpfN	22	833	94	3.5–34.5	1.1–10.5
32M060HHvpfN	29	680	77	4.6–46.0	1.4–14.0
32M050HHvpfN	35	1206	136	5.5–55.2	1.7–16.8
32M040HHvpfN	43	1023	116	6.9–69.0	2.1–21.0
32M030HHvpfN	58	1217	138	9.2–92.0	2.8–28.0
32M025HHvpfN	69	1069	121	11.0–110	0.4 3.4–33.7
32M020HHvpfN	86	1184	134	13.8–138.0	4.2–42.1
32M015HHvpfN	115	910	103	18.4–184.0	5.6–56.1
32M010HHvpfN	173	636	72	27.6–276.0	8.4–84.1
32M008HHvpfN	230	482	54	36.8–368.0	11.2–112.2

Table 4: Belt Speeds for Variable Speed 90° VFD Integrated Motor Control Gearmotors

Standard Load Gearmotors				Belt Speed	
Part Number	RPM	In-lb	N-m	Ft/min	M/min
32M100HH411EC	17	913	103	4.6–36.7	1.4–11.2
32M060HH411EC	29	680	77	7.7–61.2	2.3–18.7
32M040HH411EC	43	1023	116	11.5–91.8	3.5–28.0
32M015HH411EC	69	712	80	18.4–146.8	5.6–44.8
32M020HH411EC	86	592	67	23.0–183.5	7.0–56.0
32M015HH411EC	115	455	51	30.7–244.7	9.4–74.6

(vp) = voltage and phase

11 = 115 V, 1-phase

23 = 208 – 230/460 V, 3-phase

NOTE

For belt speed other than those listed, contact factory for details.

NOTE

Conveyor **MUST** be mounted straight, flat and level within confines of conveyor. Use a level (Figure 3, item L) for setup.



Figure 3

Required Tools

- Hex-key wrenches:
4 mm, 5 mm
- Level
- Torque wrench
- 8 mm Hex, Open End Wrench

Recommended Installation Sequence

- Install support stands (see accessory instructions)
- Assemble conveyor (if required)
- Attach mounting brackets to conveyor
- Attach conveyor to stands
- Install return rollers on conveyor (optional)
- Mount gearmotor mounting package (see page 9)
- Attach guides/accessories (see page 36 through 45 of “Service Parts” section for details)

Conveyors Up to 13 ft (3962 mm)

No assembly is required. Install mounting brackets and return rollers. Refer to “Mounting Brackets” on page 8 and “Return Rollers” on page 8.

Conveyors Longer Than 13 ft (3962 mm)

1. Locate and arrange conveyor sections by section labels (Figure 4, item N).

M	Conveyor frame
N	Section Label

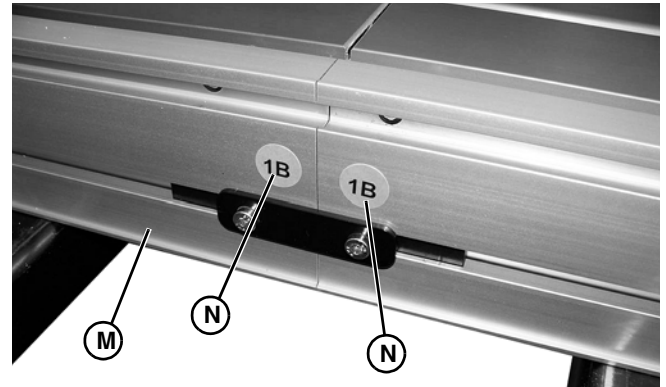

Figure 4

2. Roll out conveyor belt and place conveyor frame sections (Figure 5, item M) into belt loop.



Figure 5

3. Join conveyor sections and install connector brackets (Figure 6, item Q) or connector/mount brackets (QA) and screws (R) on both sides as indicated. Tighten screws to 60 in-lb (7 Nm).

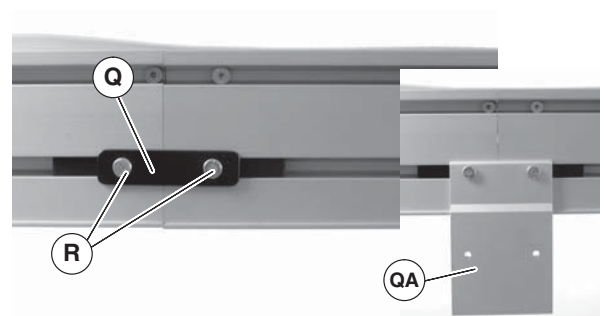

Figure 6

4. Install mounting brackets and return rollers. Refer to “Mounting Brackets” on page 8 and “Return Roller” on page 8.
5. Install Gearmotor. See “Gearmotor Installation” section on page 9.
6. Tighten conveyor belt, refer to “Conveyor Belt Tensioning” on page 15.
7. If belt tracking is necessary, refer to “Conveyor Belt Tracking” on page 16 and “Center Drive Module Tracking” on page 17.

Installation

Mounting Brackets

1. Locate brackets. Exploded views shown in Figure 7.

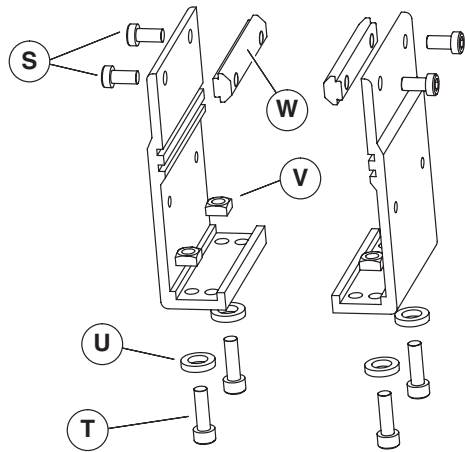

Mounting Brackets for Flat Belt Conveyor

Figure 7

2. Remove screws (Figure 7, item S & T), washers (U), nuts (V) and T-bars (W) from brackets.
3. Insert T-bars (Figure 7, item W) into conveyor side slots (Figure 8, item W). Fasten brackets (Figure 8, item X) to conveyor with mounting screws (S).

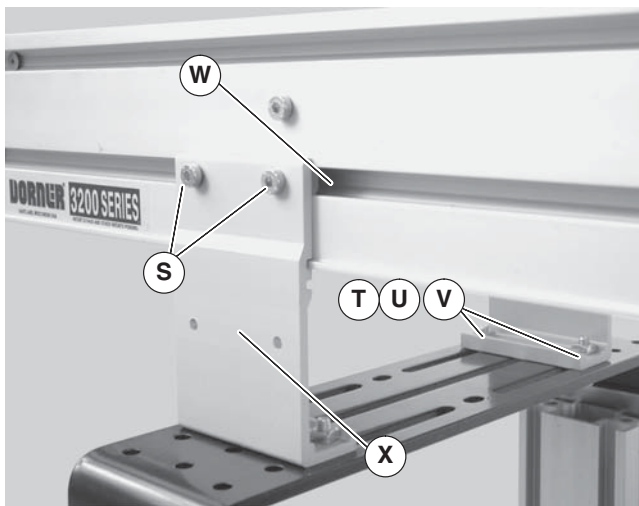

Figure 8

4. Fasten brackets to support stand with mounting screws (Figure 8, item T), washers (U) and nuts (V).
5. Tighten screws (Figure 7, item S & T) to 60 in-lb (7 Nm).

Return Rollers

4–6" (51–152 mm) Wide Conveyors

1. Locate return rollers. Exploded view shown in Figure 9.

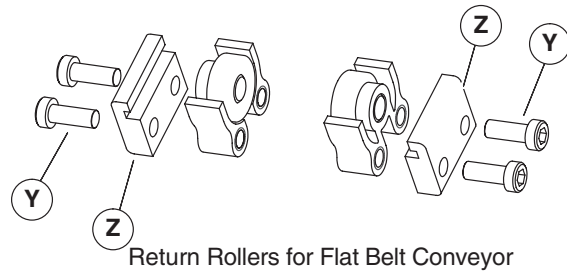

Return Rollers for Flat Belt Conveyor

Figure 9

2. Remove screws (Figure 9, item Y) and clips (Z) from roller assembly.
3. Install roller assemblies (Figure 10, item AA) as shown. Tighten screws (Y) to 60 in-lb (7 Nm)

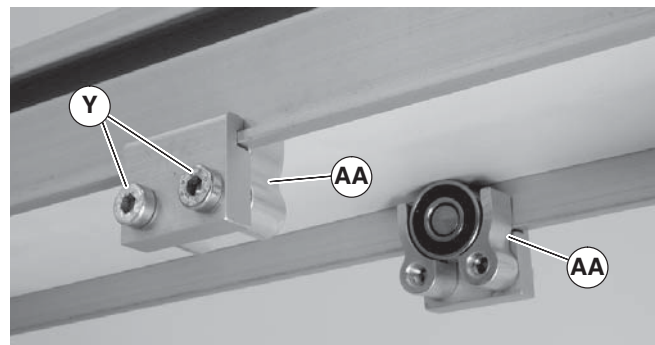

Figure 10

8–48" (203–1219 mm) Wide Conveyors

1. Locate return rollers. Exploded view shown in Figure 11.

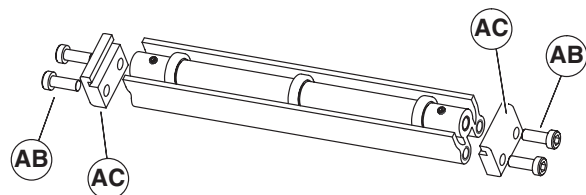

Figure 11

2. Remove screws (Figure 11, item AB) and clips (AC) from roller assembly.
3. Install roller assembly as shown (Figure 12, item AD). Tighten screws (AB) to 60 in-lb (7 Nm).

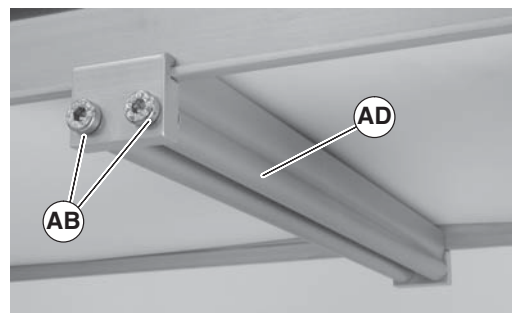

Figure 12

Gearmotor Installation

Required Tools

- Hex key wrenches: 2 mm, 2.5 mm, 3 mm, 5 mm
- Torque wrench

Mounting

⚠ WARNING



Exposed moving parts can cause severe injury.

LOCK OUT POWER before removing guards or performing maintenance.

1. Locate components of Figure 13.

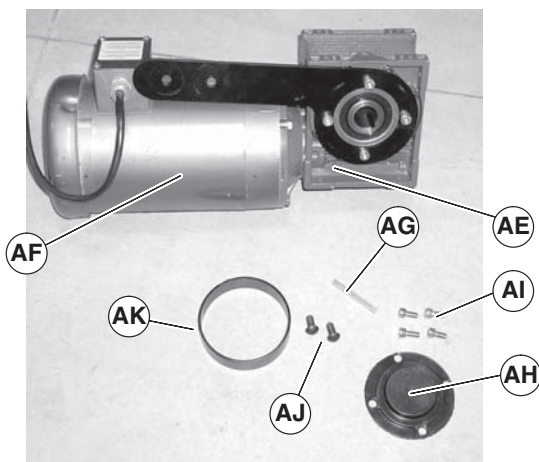

Figure 13

Gearmotor Installation Component List	
AE	Gearhead with mounting bracket
AF	Motor
AG	Gear Reducer Key
AH	Cover
AI	Cover Bolts
AJ	Motor Mount Bolts
AK	Spacer Ring

NOTE

Gearmotor may be operated in positions 1, 3 or 4 (Figure 14).

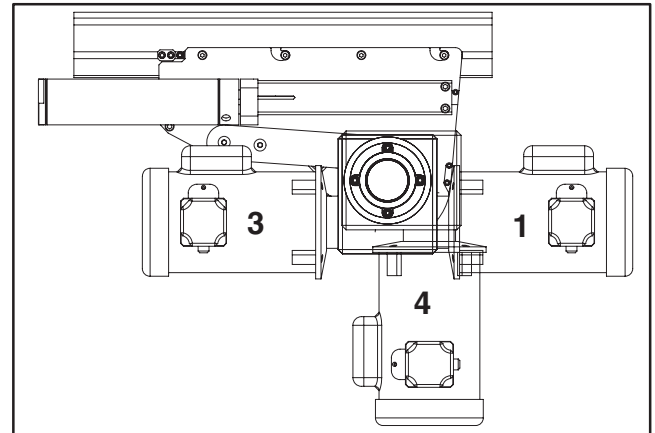

Figure 14

2. If required, change gearmotor position by removing four (4) screws (Figure 15, item AL). Rotate gearmotor mounting plate to other position and replace screws (AL). Tighten to 200 in-lb (22.5 Nm).

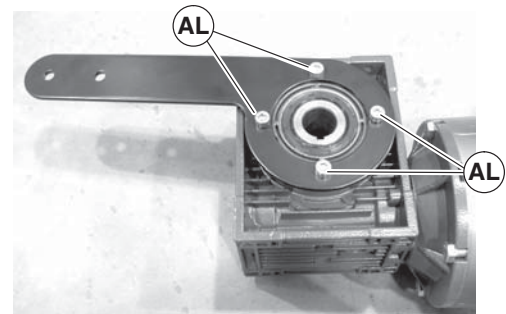

Figure 15

Installation

⚠ WARNING



Drive shaft keyway may be sharp.
HANDLE WITH CARE.

3. Install key (Figure 16, item AG) on drive shaft (AM).
Install cover (AH) over bearing housing (AN)

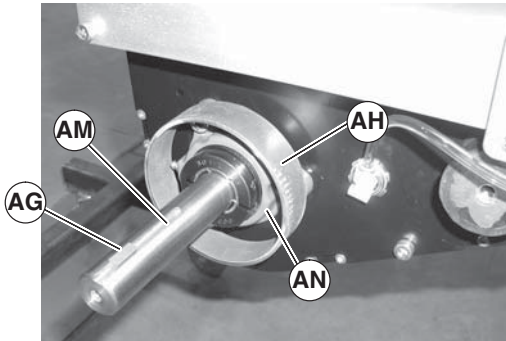

Figure 16

4. Install cover (Figure 17, item AH) with four (4) screws (AI).

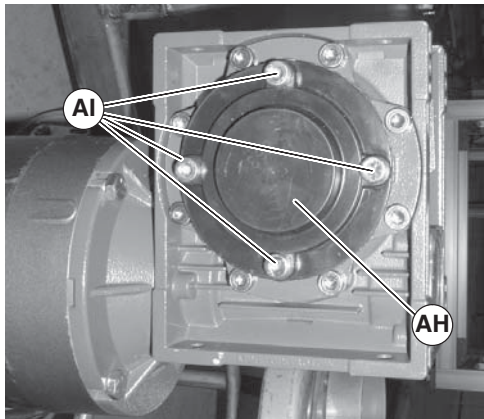

Figure 17

5. Slide gearmotor (Figure 18, item AE) on to drive shaft (Figure 16, item AM). Tighten mounting screws (AJ) to 200 in-lbs (22.5 N-m).

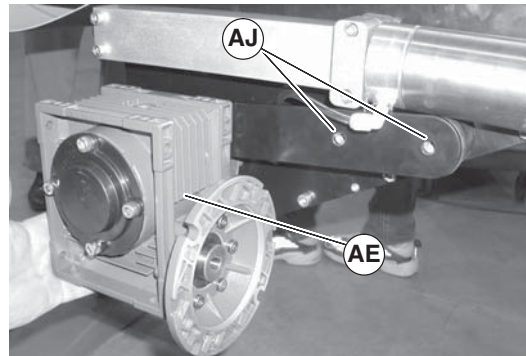

Figure 18

Preventive Maintenance and Adjustment

Required Tools

Standard Tools

- Hex-key wrenches:
2.5 mm, 4 mm, 5 mm, 6 mm
- 8 mm Hex, Open End Wrench

Checklist

- Keep service parts on hand (see “Service Parts” section for recommendations)
- Keep supply of belt cleaner (part # 625619)
- Clean entire conveyor and knurled pulley while disassembled
- Replace worn or damaged parts

Lubrication

No lubrication is required. Replace bearings if worn.

Maintaining Conveyor Belt

Troubleshooting

Inspect conveyor belt for:

- Surface cuts or wear
- Stalling or slipping
- Damage to V-guide

Surface cuts and wear indicate:

- Sharp or heavy parts impacting belt
- Jammed parts
- Improperly installed bottom wipers (if installed)
- Accumulated dirt in wipers (if installed)
- Foreign material inside the conveyor
- Improperly positioned accessories
- Bolt-on guiding is pinching belt

Stalling or slipping indicates:

- Excessive load on belt
- Conveyor belt or drive timing belt are not properly tensioned
- Worn knurl or impacted dirt on drive pulley
- Intermittent jamming or drive train problems

Damage to V-guide indicates:

- Twisted or damaged conveyor frame
- Dirt impacted on pulleys
- Excessive or improper side loading

Cleaning

IMPORTANT

Do not use belt cleaners that contain alcohol, acetone, Methyl Ethyl Ketone (MEK) or other harsh chemicals.

Use Dorner Belt Cleaner (part # 625619). Mild soap and water may also be used. Do not soak the belt.

For /05 woven polyester and /06 black anti-static belts, use a bristled brush to improve cleaning.

Conveyor Belt Replacement

⚠ WARNING



Exposed moving parts can cause severe injury.

LOCK OUT POWER before removing guards or performing maintenance.

⚠ WARNING



Exposed moving parts can cause severe injury.

REMOVE COMPRESSED AIR SUPPLY before removing guards or performing maintenance.

Conveyor Belt Replacement Sequence

Remove old conveyor belt:

- Conveyor without Stands or Gearmotor Mounting Package

Conveyor with Stands and Gearmotor Mounting Package

- Install new conveyor belt
- Tension conveyor belt

Preventive Maintenance and Adjustment

Belt Removal for Conveyor Without Stands

1. Remove air supply and remove hose (Figure 19, item AO) from center drive.

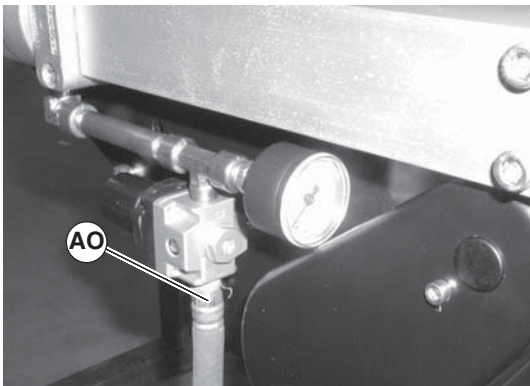

Figure 19

2. If equipped, remove return rollers and guiding and accessories from one side of conveyor.
3. Temporarily support idler guard assembly (Figure 20, item AP). Remove screws (AQ).

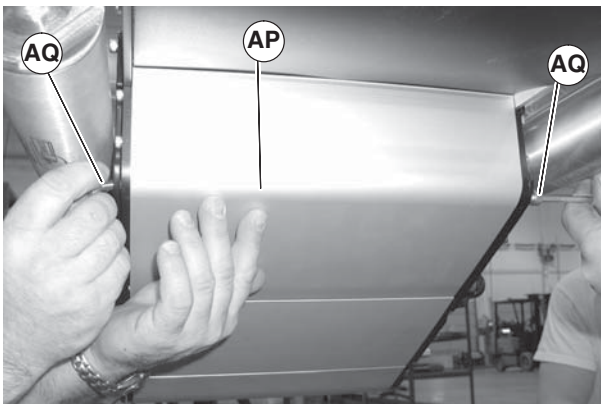

Figure 20

4. Swing down idler guard assembly (Figure 21, item AP). Remove screw (AR) from both sides of center drive and remove idler guard assembly (AP).



Figure 21

5. Remove screws (Figure 22, item AS) and tensioning guards (AT) from both sides of center drive.

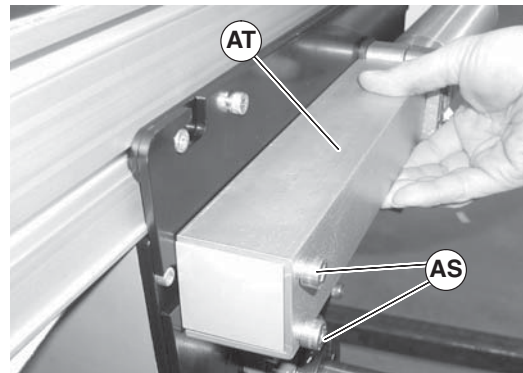

Figure 22

6. Temporarily support the tensioning roller guard (Figure 23, item AV). Remove screws (Figure 23, item AU) on both sides of center drive and remove tensioning roller guard (Figure 23, item AV) and (Figure 24, item AV).

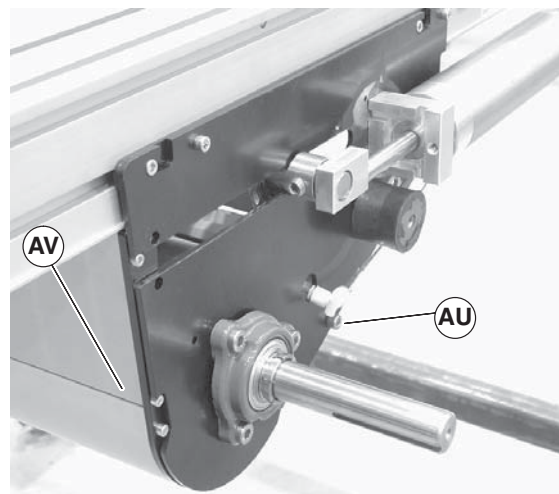

Figure 23

7. Loosen tensioning roller set screws (Figure 24, item AW).

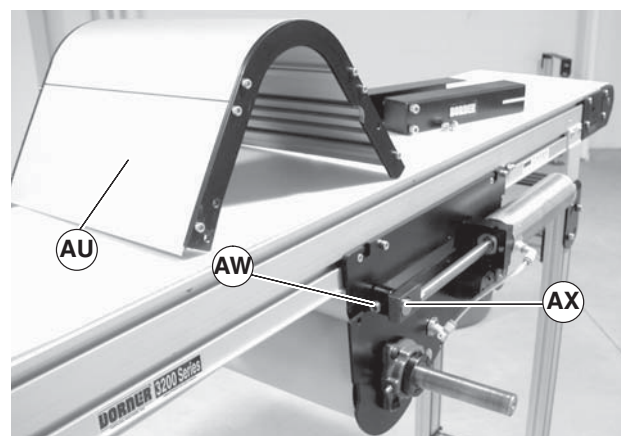

Figure 24

Preventive Maintenance and Adjustment

8. Push shaft (Figure 24, item AX) through block, and slide block (Figure 25, item AY) towards air cylinder (AZ).

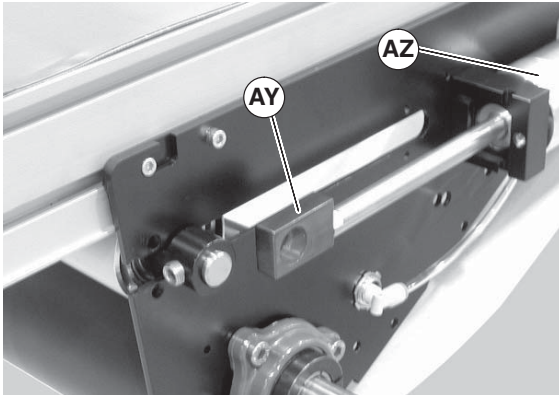

Figure 25

9. Push shaft (Figure 26, item AX) through block (AY) on opposite side of center drive, slide block toward air cylinder (AZ).

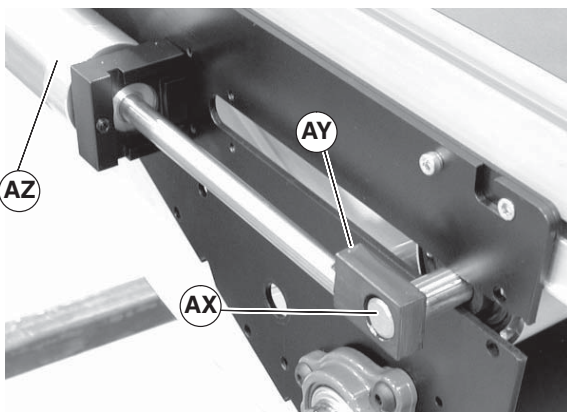

Figure 26

10. Slide out tensioning roller (Figure 27, item BA).

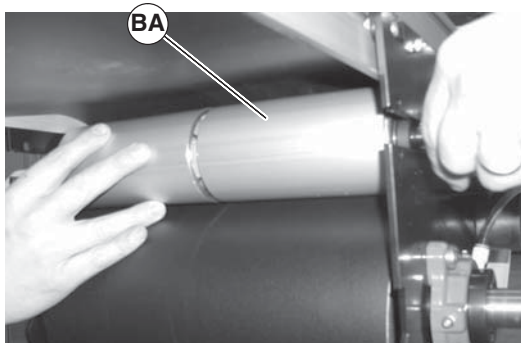

Figure 27

11. Remove belt (Figure 28, item BB) from center drive module (B) and conveyor.

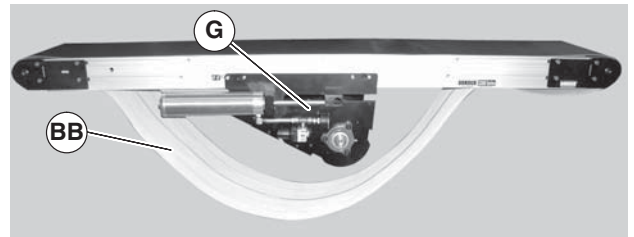



Figure 28

Belt Removal for Conveyor With Stands

⚠ WARNING

Removing mounting brackets without support under gearmotor will cause conveyor to tip, causing severe injury. PROVIDE SUPPORT UNDERNEATH THE GEARMOTOR WHEN CHANGING THE BELT

1. Place temporary support stands (Figure 29, item BC) at both ends of the conveyor. See WARNING.

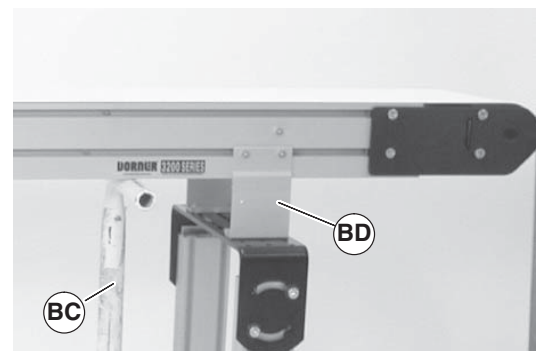

Figure 29

2. If equipped, remove return rollers, guiding and accessories from one side of conveyor.
3. Repeat steps 1 thru 10 of the “Belt Removal for Conveyors Without Stands” section on page 12.
4. Remove first mounting brackets (Figure 29, item BD) from one side of conveyor. (Reverse steps 3 & 4 of “Mounting Brackets” section on page 8).

Preventive Maintenance and Adjustment

- Remove belt (Figure 30, item BB) from conveyor, one stand at a time. Start on one end of conveyor and work down to opposite end.

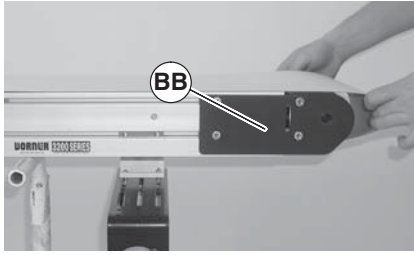

Figure 30

Belt Installation for Conveyor without Stands

- Orient belt so splice leading fingers (Figure 31, item BE) point in the direction of belt travel as identified by the conveyor directional label (BF).

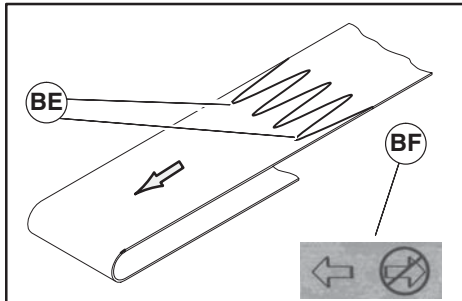

Figure 31

- Slide belt onto the conveyor frame assembly.
- Reverse steps 1 thru 10 of the “Belt Removal for Conveyors Without Stands” section on page 12.
- If equipped, install wipers, return rollers and guiding.
- Reattach air supply (Figure 32, item AO) to center drive. Refer to “Conveyor Belt Tensioning” section on page 15 for more information.

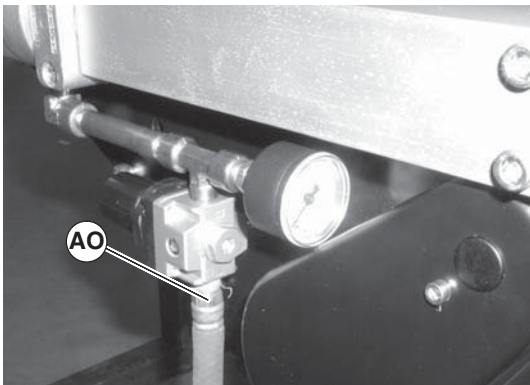



Figure 32

- Track conveyor and center drive if required. See “Center Drive Module Tracking” section on page 17 and “Conveyor Belt Tracking” section on page 16.

Belt Installation for Conveyor with Stands

⚠ WARNING



Removing mounting brackets without support under gearmotor will cause conveyor to tip, causing severe injury. PROVIDE SUPPORT UNDERNEATH THE GEARMOTOR WHEN CHANGING THE BELT

- Ensure temporary support stands (Figure 29, item BC) are placed at both ends of the conveyor. See WARNING.
- Orient belt so splice leading fingers (Figure 31, item BE) point in the direction of belt travel as identified by the conveyor directional label (BF).
- Install belt (Figure 33, item BB) on conveyor. Lift conveyor slightly to avoid pinching belt on temporary support stands.

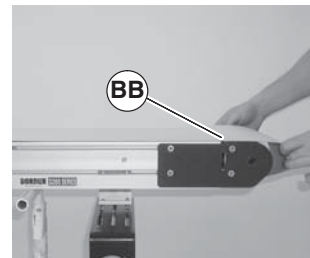



Figure 33

- Reverse steps 1 thru 10 of the “Belt Removal for Conveyors Without Stands” section on page 12.
- Re-install conveyor mounting brackets. Refer “Mounting Brackets” on page 8, steps 3 through 5.
- If equipped, install wipers, return rollers and guiding.
- Reattach air supply (Figure 32, item AO) to center drive. Refer to “Conveyor Belt Tensioning” section on page 15 for more information.
- Track drive and conveyor if required. See “Center Drive Module Tracking” section on page 17 and “Conveyor Belt Tracking” section on page 16.

Preventive Maintenance and Adjustment

Conveyor Belt Tensioning

⚠ WARNING



Exposed moving parts can cause severe injury.

LOCK OUT POWER before removing guards or performing maintenance.

A - With Pneumatic Tensioning

1. Connect air supply (Figure 34, item AO) to regulator (BG).
2. Adjust regulator (Figure 34, item BG) until gage reads the appropriate pressure. Adjust regulator starting at 15 psi sufficiently to keep belt from slipping up to the maximum shown in the following table.

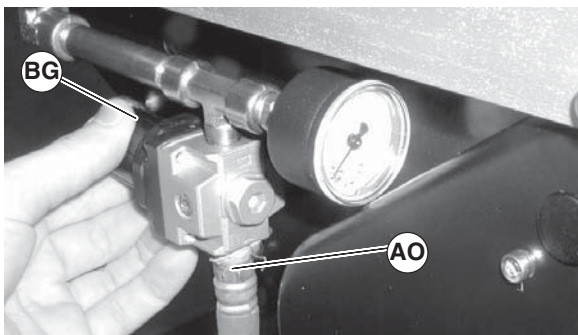

Figure 34

Suggested Maximum Tensioning Air Pressure for LPZ & 3200 Series Flat Belt Center Drive Conveyors	
Width	Pressure
4" (95 mm)	20 psi (138 kPa)
6" (152 mm)	30 psi (207 kPa)
8" (203 mm)	40 psi (276 kPa)
10" (254 mm)	50 psi (345 kPa)
14" (356 mm)	60 psi (414 kPa)
18" (457 mm)	70 psi (483 kPa)
24" (610 mm) & wider	80 psi (552 kPa)

3. If proper belt tension cannot be achieved before the out of tension indicator (Figure 35, item BH) begins to turn red, the belt must be replaced.

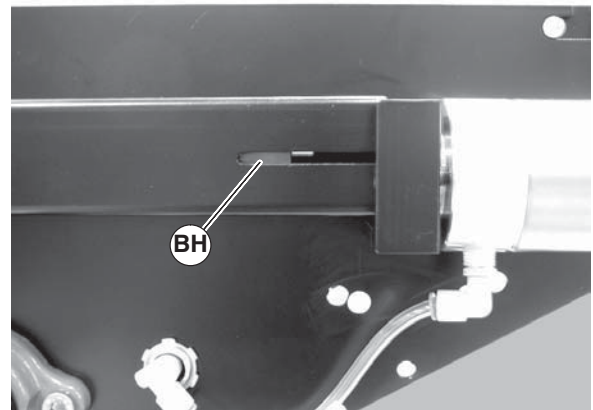

Figure 35

4. If belt tracking is necessary, refer to "Conveyor Belt Tracking" on page 16 and "Center Drive Module Tracking" on page 17.

Preventive Maintenance and Adjustment

B - With Manual Tensioning

⚠ WARNING

Threaded rod end may be sharp. Cover with guard while adjusting tension knob. HANDLE WITH CARE.

1. Turn knurled knob (Figure 36, item BJ) on each side of center drive unit clockwise until tensioning spring (BK) is completely behind spring cover (BL). There should be approximately 1/8" gap () between hand knob (BM) and spring cover (BL).

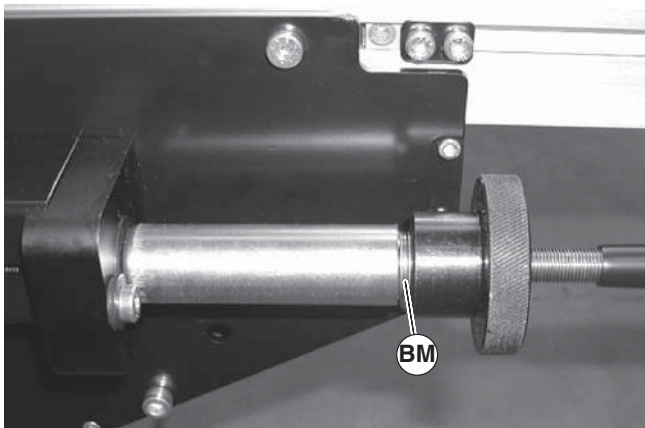
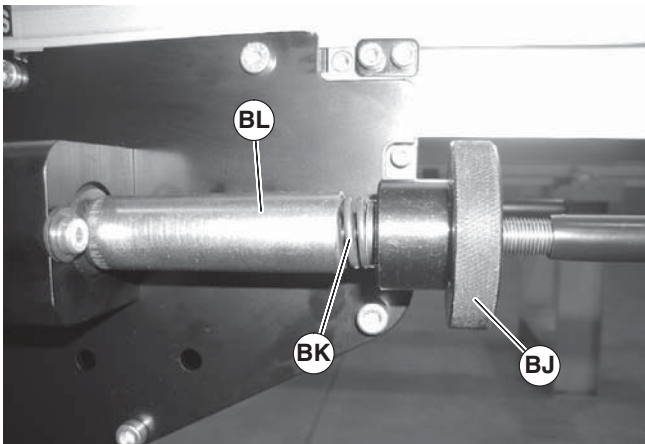

Figure 36

2. As normal belt stretch occurs over time, the spring (Figure 36, item BK) will be exposed out of the spring cover (BL). When the spring is exposed over 1/2" or if conveyor belt slippage occurs, retighten knurled hand knob (BJ) on each side of center drive unit clockwise until tensioning spring is completely behind spring cover.

3. If proper belt tension cannot be achieved before the out of tension indicator (Figure 35, item BH) begins to turn red, the belt must be replaced.
4. If belt tracking is necessary, refer to "Conveyor Belt Tracking" on page 16 and "Center Drive Module Tracking" on page 17.

Conveyor Belt Tracking

V-Guided Belts

V-guides on belts help maintain proper belt tracking. Track as needed to reduce belt bulge from center of belt (Figure 37). See steps below in "Non V-guided Belts" procedure for adjusting for any belt bulging. Belt bulge will be minimal when belt is properly tracked.

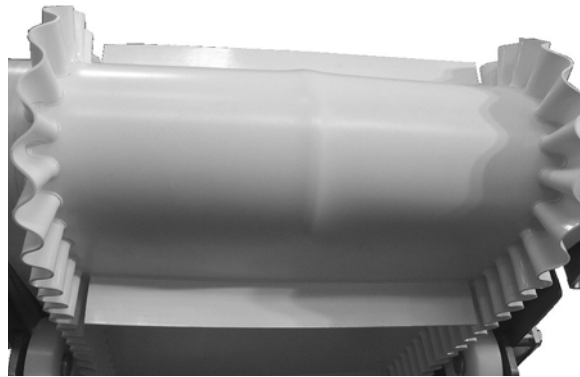

Figure 37

Non V-Guided Belts

Non V-guided belt conveyors are equipped with belt tracking assemblies.

When adjusting belt tracking, always adjust the discharge end of the conveyor first. To adjust belt tracking:

1. On the side of conveyor which the belt is tracking towards, loosen the head plate fastening screws (Figure 38, item BN).

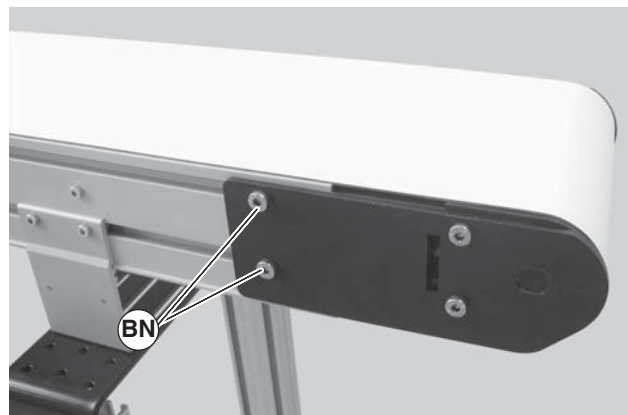

Figure 38

Preventive Maintenance and Adjustment

2. With the conveyor running, use wrench (Figure 39, item BO) to rotate the tracking screw (Figure 40, item BP) in small increments until the belt tracks in the center of the conveyor.

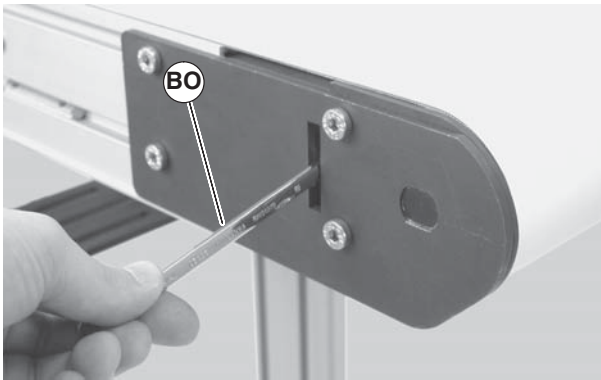

Figure 39

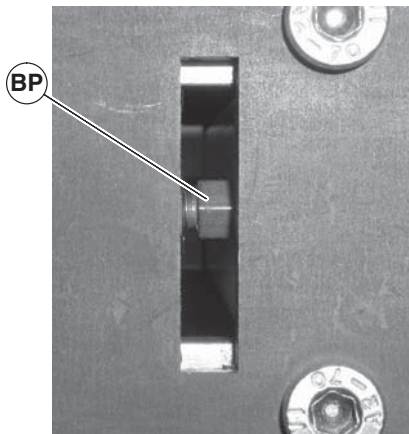

Figure 40

3. Re-tighten the head plate fastening screws (Figure 38, item BN) with a 5 mm hex-key wrench to 146 in-lb (16.5 Nm).

Center Drive Module Tracking

V-Guided Belts

V-guided belts do not require tracking adjustment.

Non V-Guided Belts

Non V-guided belt center drives are equipped with cam tracking assemblies.

To adjust center drive tracking, with the conveyor running:

1. Inspect belt as it exits the center drive:

Figure 41 – Normally tracked belt, do nothing

Figure 42 – Tracking necessary, adjust tight side cam

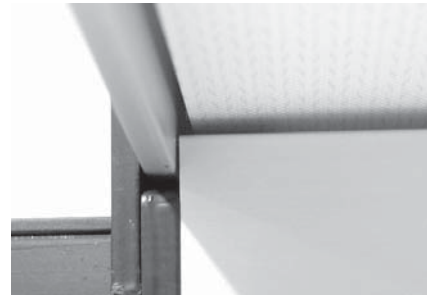

Figure 41



Figure 42

2. If necessary, adjust the tracking cam: loosen the center drive fastening screws (Figure 43, item BQ) on the side of center drive to be tracked.

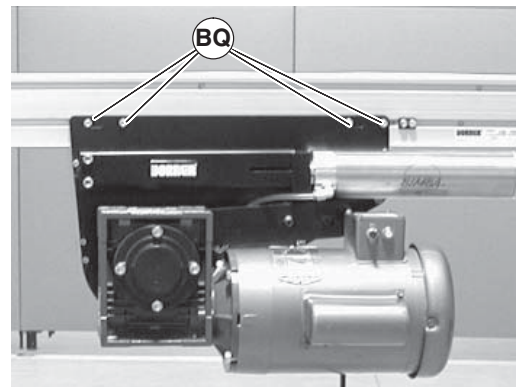

Figure 43

Preventive Maintenance and Adjustment

3. Rotate the tracking cam (Figure 44, item BR) in small increments, each time inspecting the belt as it exits the center drive. Continue to rotate the tracking cam until conveyor belt is tracking normally.

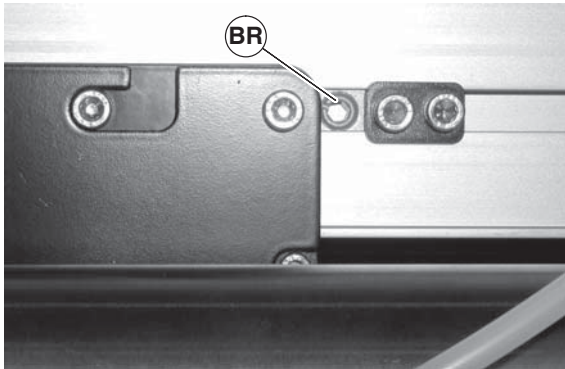

Figure 44

4. Tighten the center drive fastening screws (Figure 43, item BQ) to 146 in-lbs (16.5 N-m).

End Pulley Removal

⚠ WARNING
Exposed moving parts can cause severe injury. LOCK OUT POWER before removing guards or performing maintenance.

⚠ WARNING
Exposed moving parts can cause severe injury. REMOVE COMPRESSED AIR SUPPLY before removing guards or performing maintenance.

1. Remove air supply and remove hose (Figure 45, item AO) from center drive.

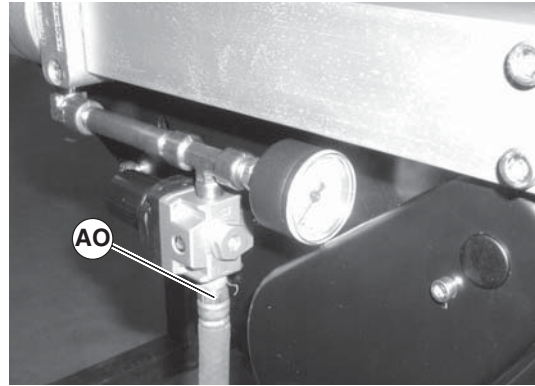

Figure 45

2. Temporarily support idler guard assembly (Figure 46, item AP). Remove screws (AQ).

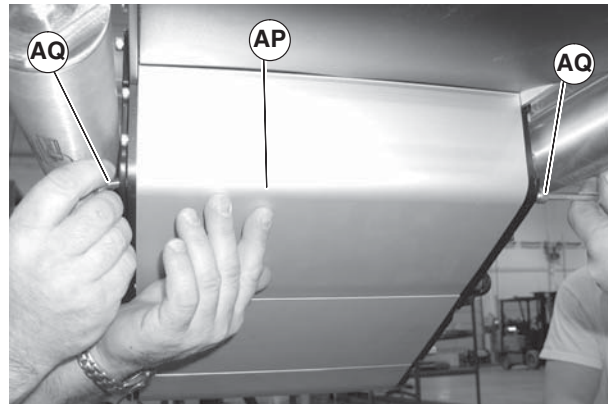

Figure 46

3. Swing down idler guard assembly (Figure 47, item AP).



Figure 47

4. Remove the desired pulley following the corresponding instructions below:
 - A – 3” Idler Pulley Removal
 - B – Transfer Tail Pulley Removal

Preventive Maintenance and Adjustment

A – Idler Pulley Removal

1. Temporarily support the idler pulley.

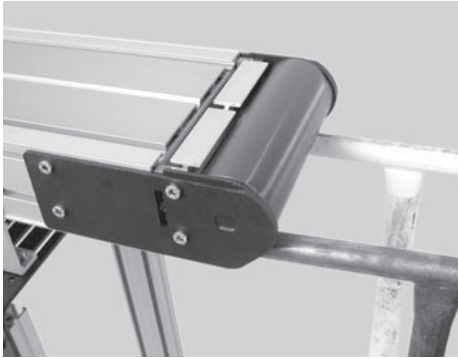

Figure 48

2. On one side of conveyor, loosen the two (2) back fastening screws (Figure 49, item BN) and remove two (2) front fastening screws (BS).

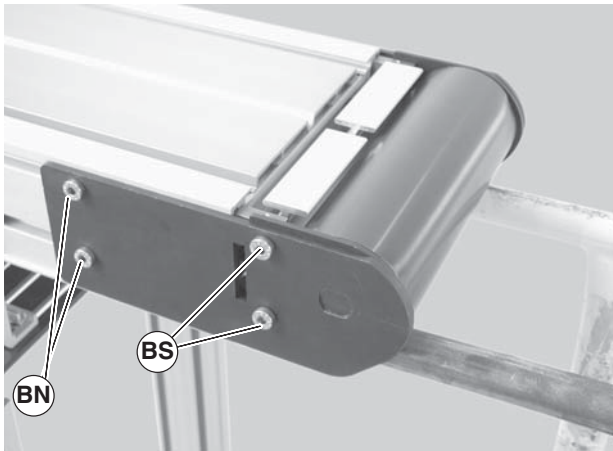

Figure 49

3. Pull back the outer headplate (Figure 50, item BT) and remove the inner spacer (BU).

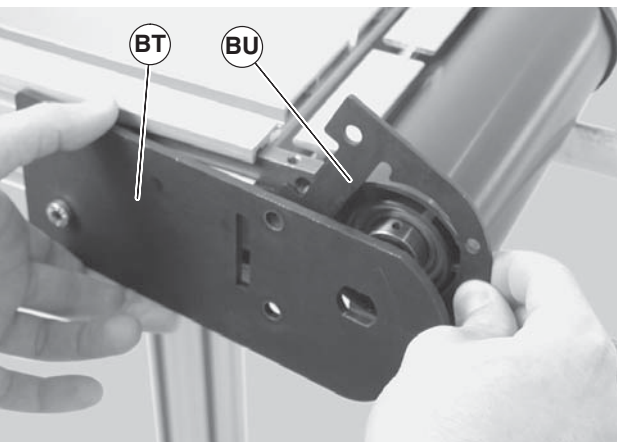

Figure 50

4. Slide the idler pulley assembly (Figure 51, item BV) out of the headplate on the opposite side.

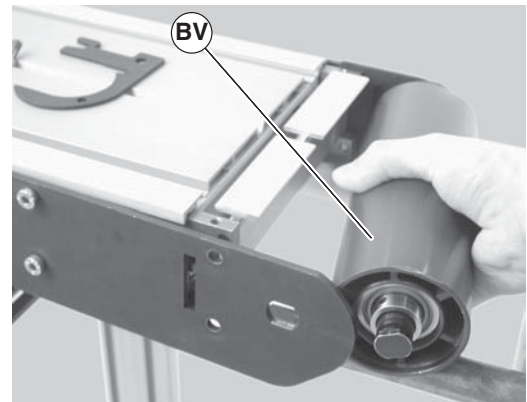

Figure 51

5. Remove the pulley shaft assembly: remove the clip ring (Figure 52, item BW) and washer (BX) from one side of the pulley assembly.

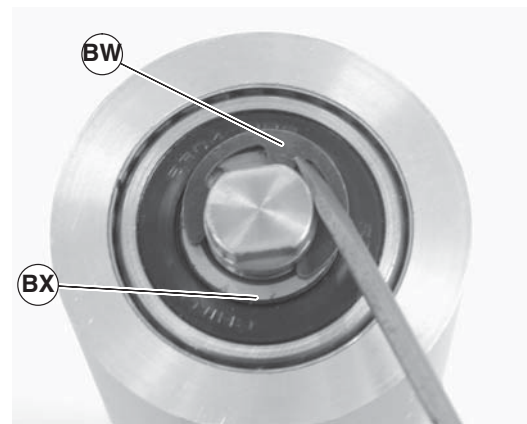

Figure 52

6. Slide the shaft assembly (Figure 53, item BY) out of the pulley (BV).

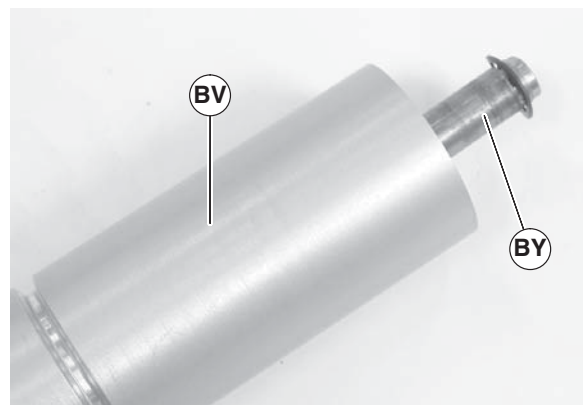

Figure 53

Preventive Maintenance and Adjustment

B – Transfer Tail Pulley Removal

1. Temporarily support the transfer tail assembly.



Figure 54

2. On one side of conveyor, loosen the two (2) back fastening screws (Figure 55, item BN), and remove the two (2) front fastening screws (BS).

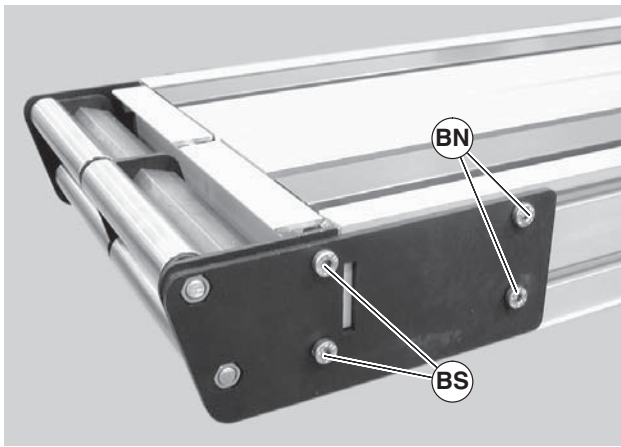

Figure 55

3. Remove the inner spacer (Figure 56, item BU).

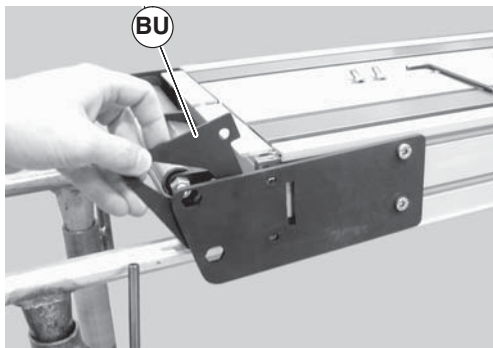

Figure 56

4. Slide the transfer tail pulley assembly (Figure 57, item CA) out of the headplate on the opposite side.

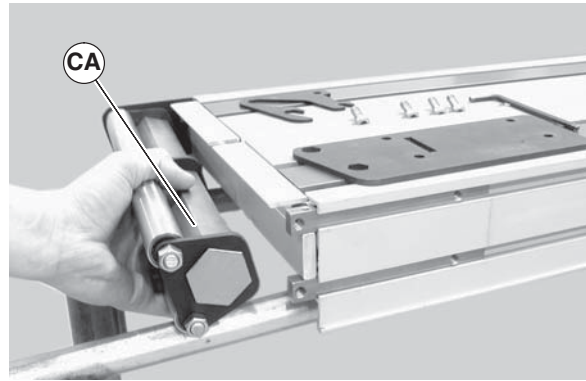

Figure 57

5. Remove hex nuts (Figure 58, item CB).

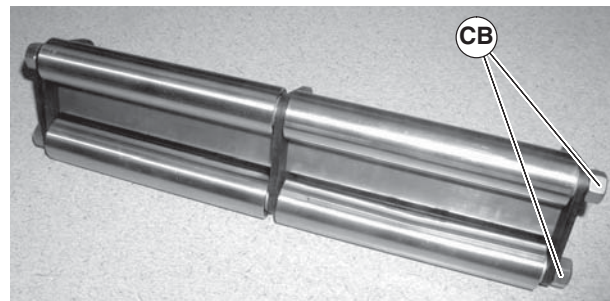

Figure 58

6. Remove support plates (Figure 59, item CC) and washers (CD).

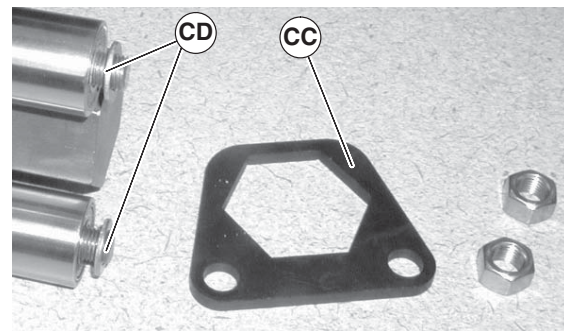

Figure 59

7. Remove pulleys (Figure 60, item CE) and additional washers (CF).

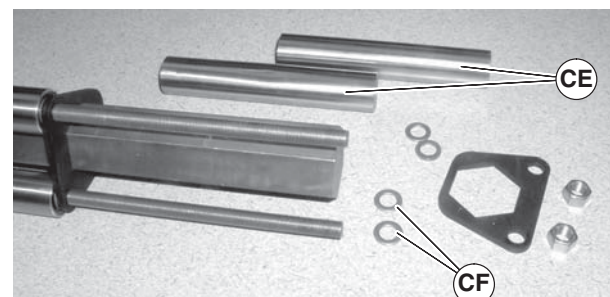



Figure 60

8. To remove additional pulleys, repeat steps 6 through 7.

Preventive Maintenance and Adjustment

Center Drive Pulleys Removal

⚠ WARNING

Exposed moving parts can cause severe injury. LOCK OUT POWER before removing guards or performing maintenance.

⚠ WARNING

Exposed moving parts can cause severe injury. REMOVE COMPRESSED AIR SUPPLY before removing guards or performing maintenance.

- A – Tensioner Pulley Removal
- B – Idler Pulley Removal
- C – Drive Pulley Removal

A – Tensioner Pulley Removal

1. Remove air supply and remove hose (Figure 61, item AO) from center drive.

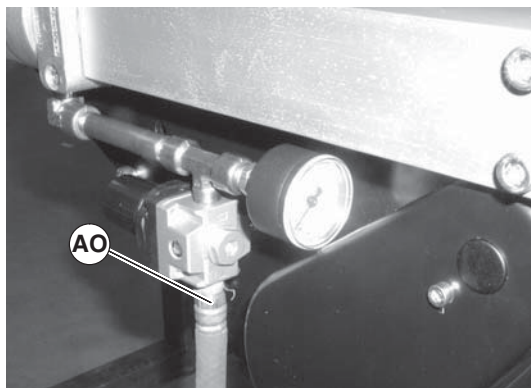

Figure 61

2. Remove screws (Figure 62, item AS) and tensioning guards (AT) from both sides of center drive.

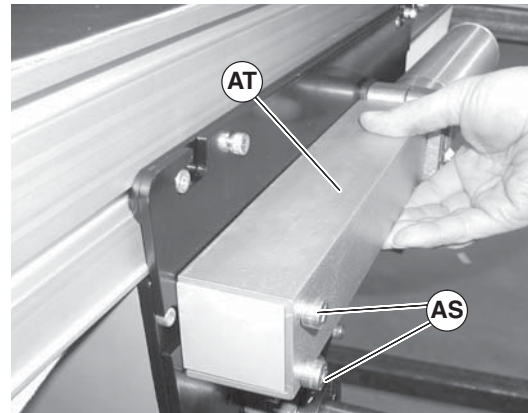

Figure 62

3. Temporarily support the tensioning roller guard (Figure 63, item AV). Remove screws (AU) on both sides of center drive and remove tensioning roller guard (Figure 63, item AV) and (Figure 64, item AV).

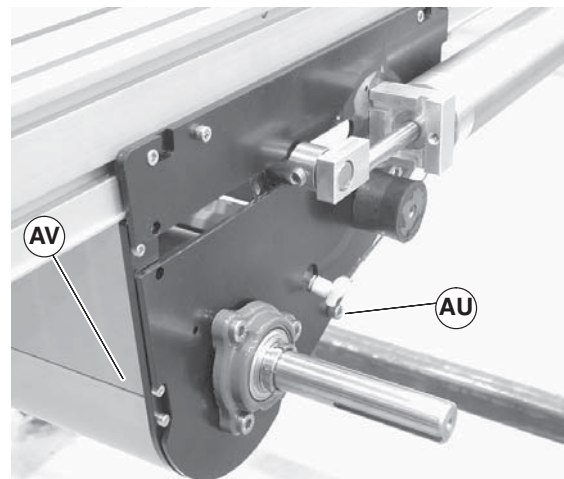

Figure 63

4. Loosen tensioning roller set screws (Figure 64, item AW) on one side of center drive.

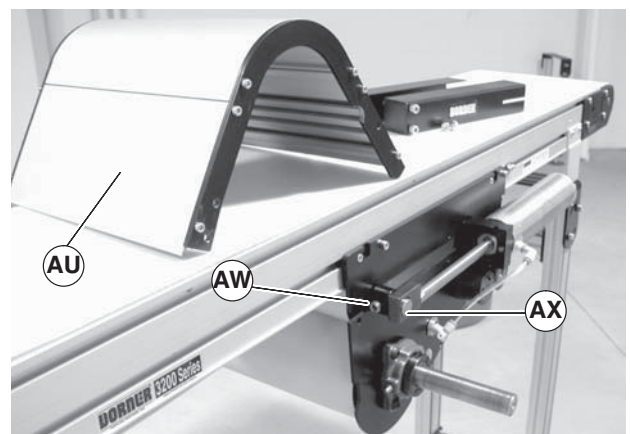

Figure 64

Preventive Maintenance and Adjustment

5. Push shaft (Figure 63, item AX) through block, slide block (Figure 65, item AY) towards air cylinder (AZ).

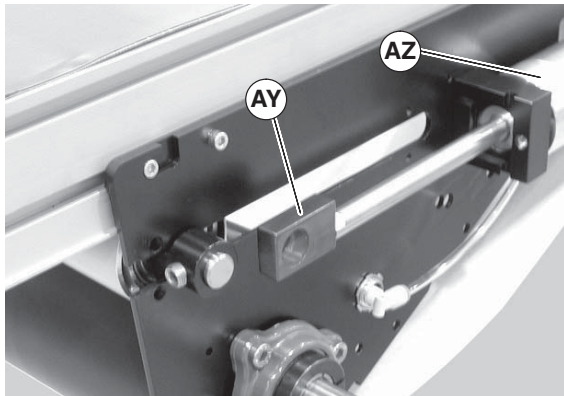

Figure 65

6. Push shaft (Figure 66, item AX) through block (AY) on opposite side of center drive, slide block toward air cylinder (AZ).

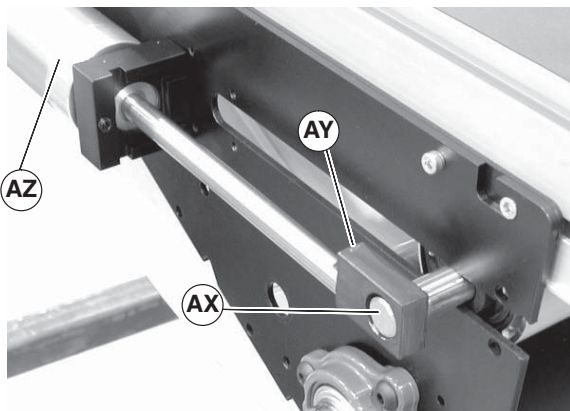

Figure 66

7. Slide out tensioning pulley (Figure 67, item BA).

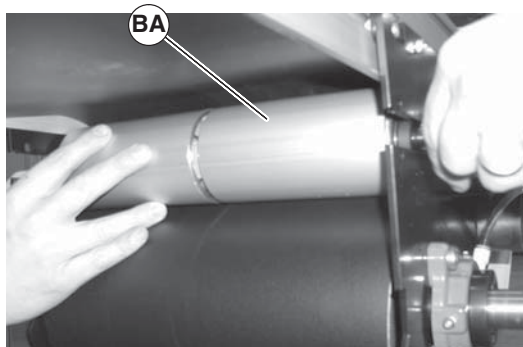

Figure 67

8. Remove the tension pulley locking collar (Figure 68, item CG), spacer (CH) and pulley shaft (CI) from the roller pulley shaft assembly.

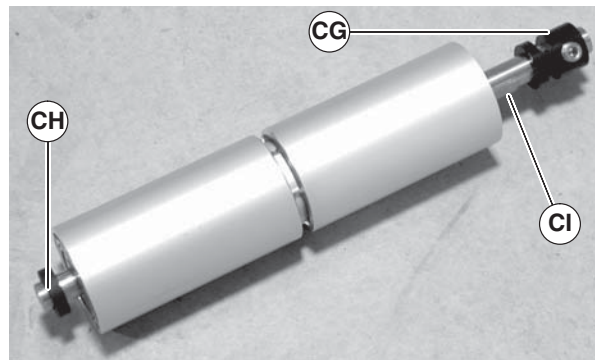

Figure 68

B – Idler Pulley Removal

1. Remove air supply and remove hose (Figure 69, item AO) from center drive.

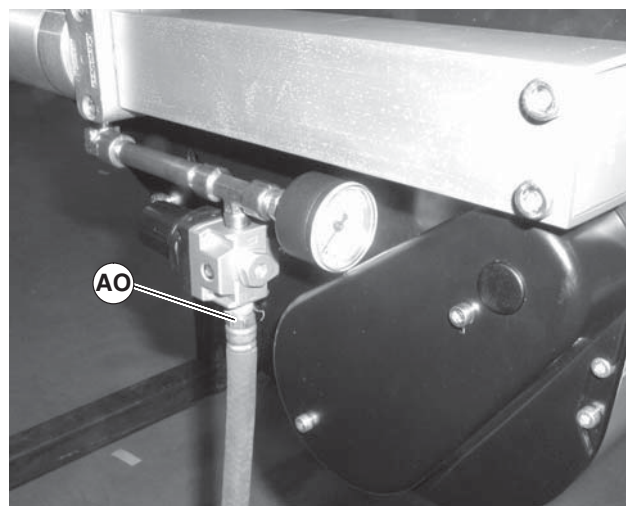

Figure 69

2. Temporarily support idler guard assembly (Figure 70, item AP). Remove screws (AQ).

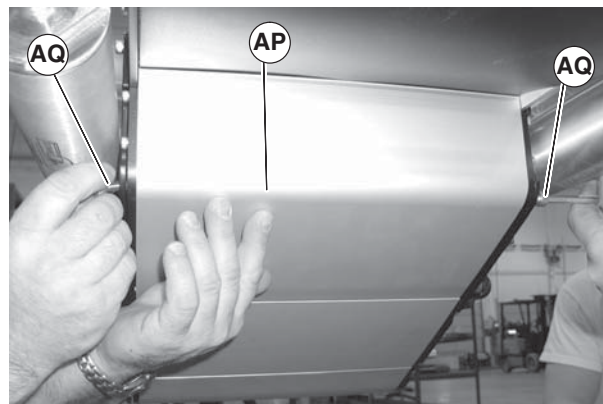

Figure 70

Preventive Maintenance and Adjustment

3. Swing down idler guard assembly (Figure 71, item AP). Remove screw (AR) from both sides of center drive and remove idler guard assembly (AP).

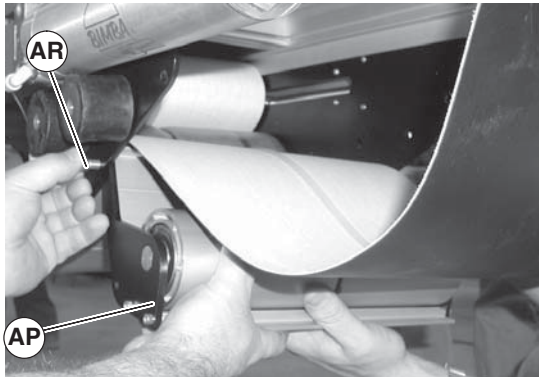

Figure 71

4. Remove screws (Figure 72, item CJ) and idler guide side plate (CK).

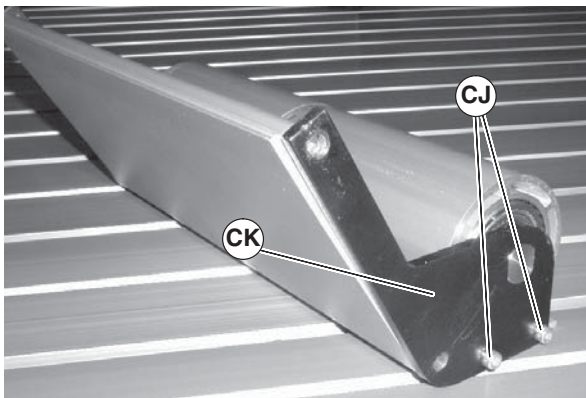

Figure 72

5. Slide the idler pulley assembly (Figure 73, item CL) out of the idler guide side plate on the opposite side.

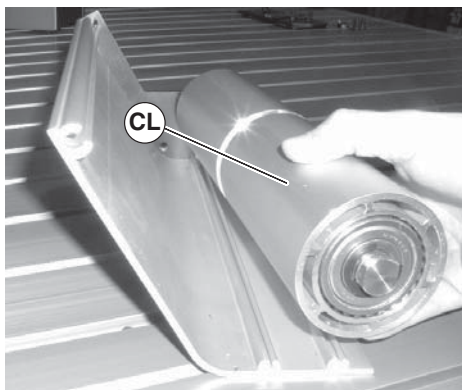

Figure 73

6. Remove the pulley shaft assembly: remove the clip ring (Figure 74, item BW) and washer (BX) from one side of the pulley assembly.

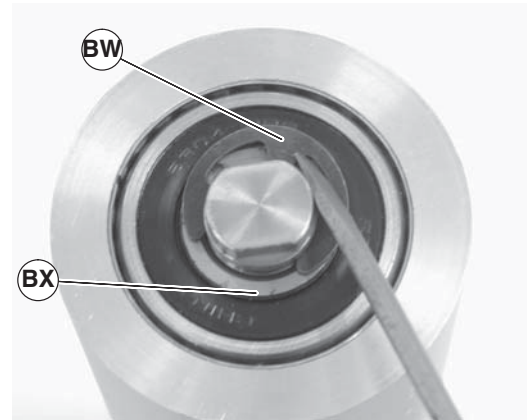

Figure 74

7. Slide the shaft assembly (Figure 75, item BY) out of the pulley (BV).

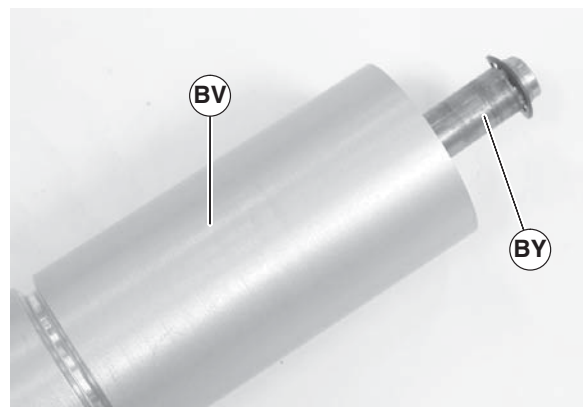

Figure 75

Preventive Maintenance and Adjustment

C – Drive Pulley Removal

⚠ WARNING



Drive shaft keyway may be sharp.
HANDLE WITH CARE.

1. Remove air supply and remove hose (Figure 76, item AO) from center drive.

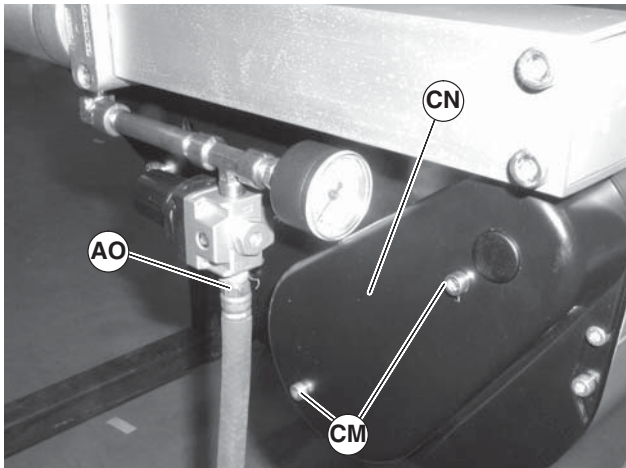

Figure 76

2. Remove screws (Figure 76, item CM) and guard (CN).
3. Remove screws (Figure 77, item CO) and remove gearmotor (CP) (Gearhead shown with motor removed for clarity, motor can remain attached to gearhead).

NOTE

Gearhead shown with motor removed for clarity, motor can remain attached to gearhead.

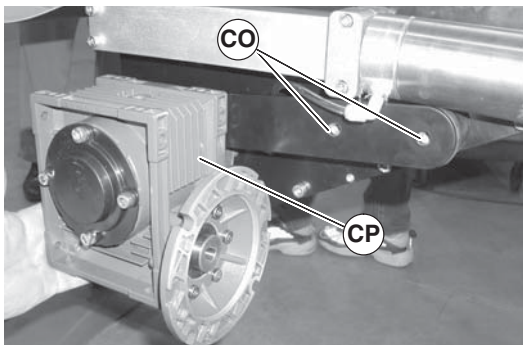

Figure 77

4. Remove spacer ring (Figure 78, item AK) and key (AG).

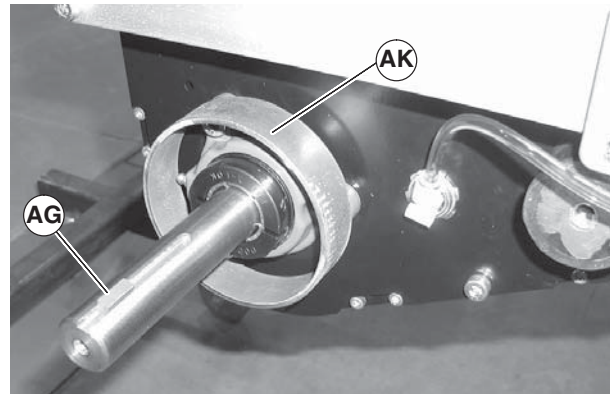

Figure 78

5. Reverse steps 3 thru 10 of the “Belt Removal for Conveyors Without Stands” section on page 12.
6. Loosen clamp screw (Figure 79, item CQ) and remove bearing collar (CR).

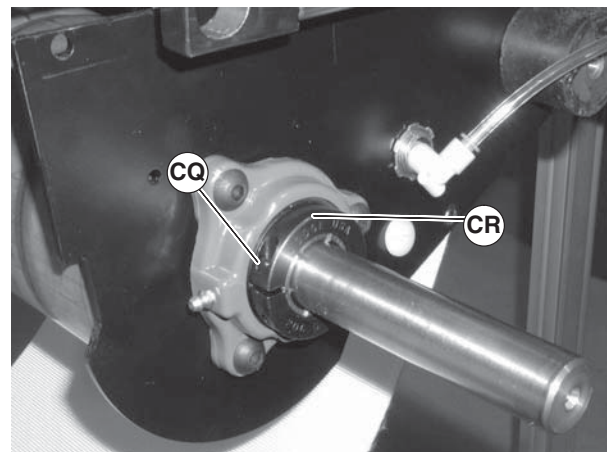

Figure 79

7. Disconnect flexible air hose (Figure 80, item CS) from fitting (CT).

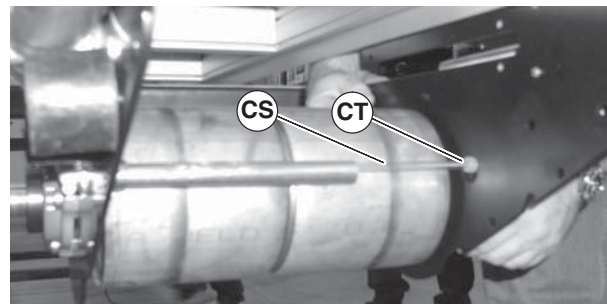

Figure 80

Preventive Maintenance and Adjustment

8. Temporarily support the drive pulley (Figure 81, item CU).

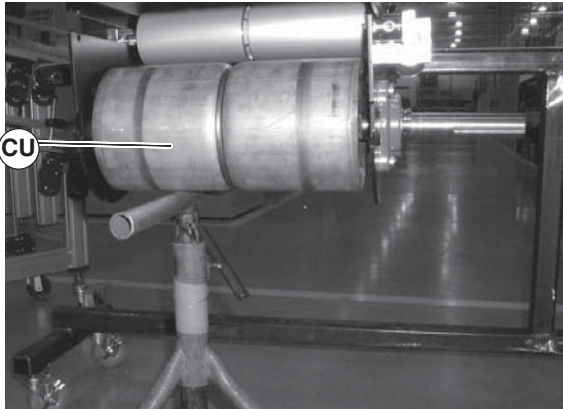

Figure 81

9. Loosen clamp screw (Figure 82, item CQ) and remove bearing collar (CR).

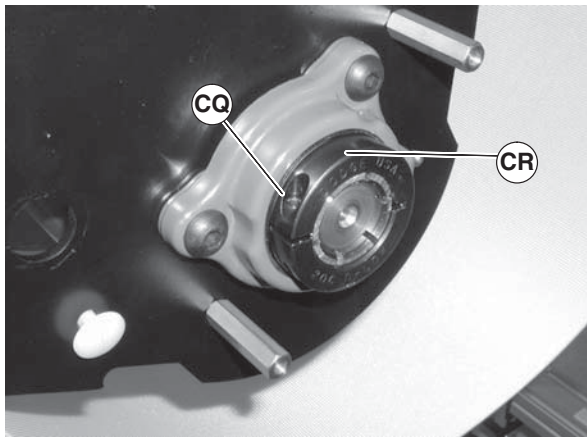

Figure 82

10. Remove screws (CV) and pull side plate assembly (CW) off conveyor.

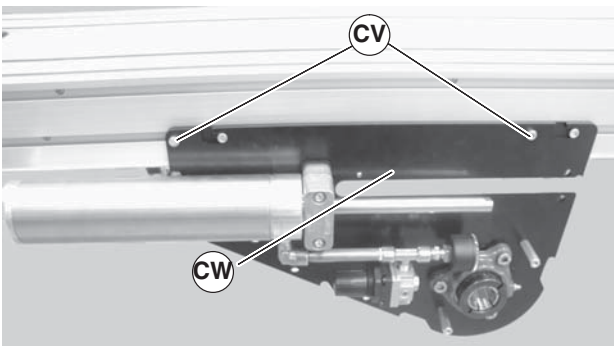

Figure 83

11. Slide drive pulley (Figure 84, item CU) out of attached side plate.

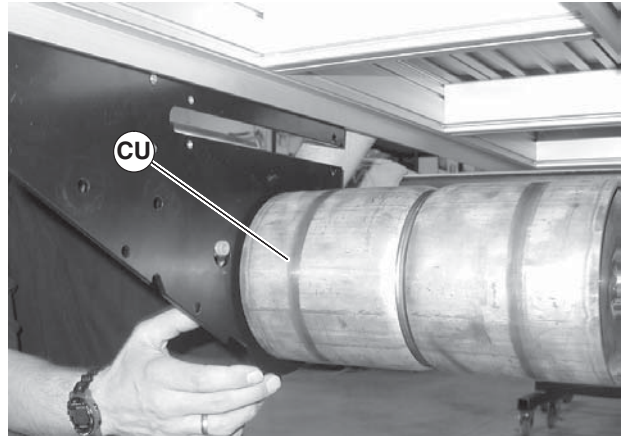

Figure 84

Bearing Replacement

⚠ WARNING



Exposed moving parts can cause severe injury.

LOCK OUT POWER before removing guards or performing maintenance.

⚠ WARNING



Exposed moving parts can cause severe injury.

REMOVE COMPRESSED AIR SUPPLY before removing guards or performing maintenance.

- A – Idler Bearing
- B – Drive Bearing
- C – Transfer Tail Bearing

Preventive Maintenance and Adjustment

A – Idler Bearing Replacement

The bearings in a 3200 Series Idler Pulley can not be removed. Replace the entire pulley assembly when worn.

B – Drive Bearing Removal and Replacement

⚠ WARNING



Drive shaft keyway may be sharp.
HANDLE WITH CARE.

Drive Side Bearing

1. Remove air supply (Figure 85, item AO) from center drive module.

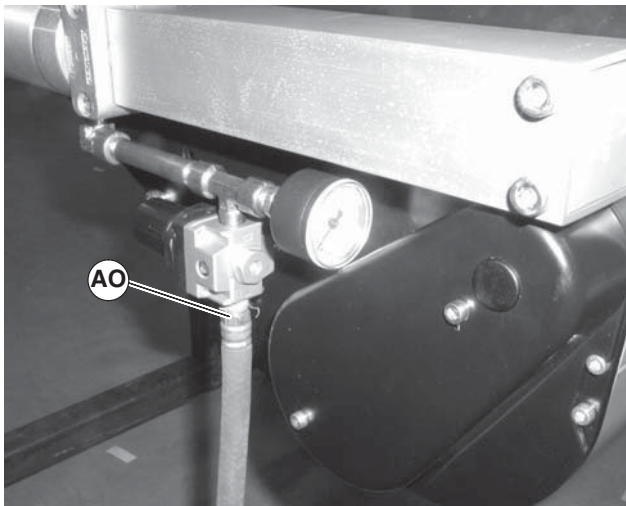

Figure 85

2. Remove screws (Figure 86, item CO) and remove gearmotor (CP) (Gearhead shown with motor removed for clarity, motor can remain attached to gearhead).

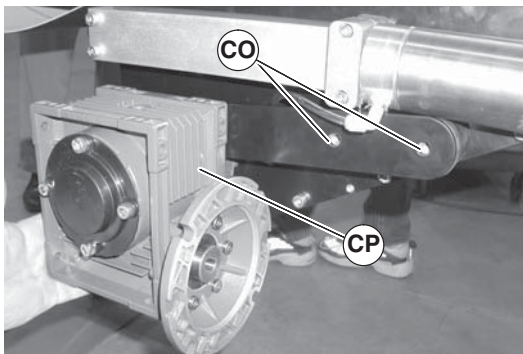

Figure 86

3. Remove spacer ring (Figure 87, item AK) and key (AG). Loosen clamp screw (CQ) and remove bearing collar (CR).

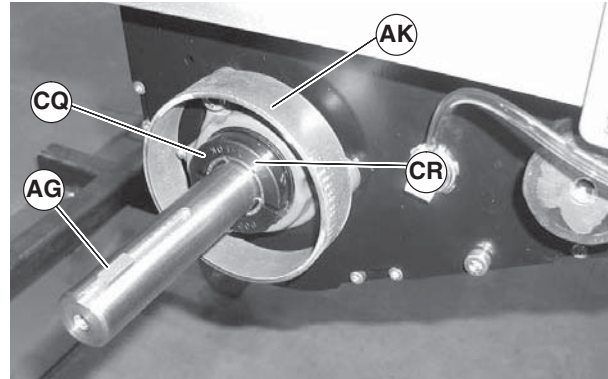

Figure 87

4. Remove the three (3) mounting screws (Figure 88, item CX).

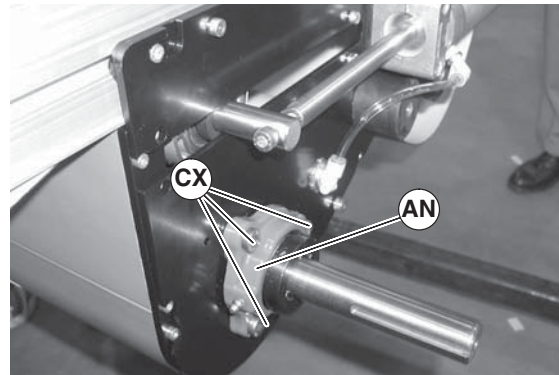

Figure 88

5. Remove and replace bearing housing assembly (Figure 88, item AN).
6. Tighten three (3) mounting screws (Figure 89, item CX) to 200 in-lbs (22.5 N-m).

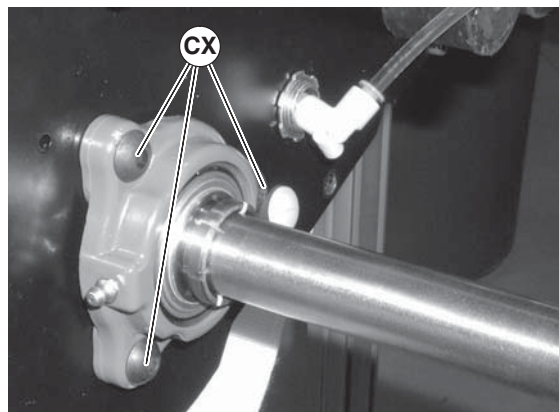

Figure 89

7. Reinstall bearing collar (Figure 87, item CR). Tighten clamp screw (CQ) to 95 in-lbs (11 N-m).
8. Reinstall key (Figure 87, item AG).

Preventive Maintenance and Adjustment

9. Reinstall spacer ring (Figure 90, item AK) and gearmotor (CP). Tighten screws (Figure 86, item CO) to 150 in-lbs (17 N-m).

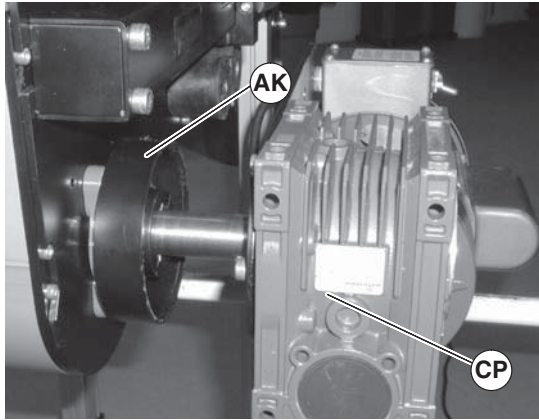

Figure 90

Idler Side Bearing

1. Remove air supply (Figure 91, item AO) from center drive module.

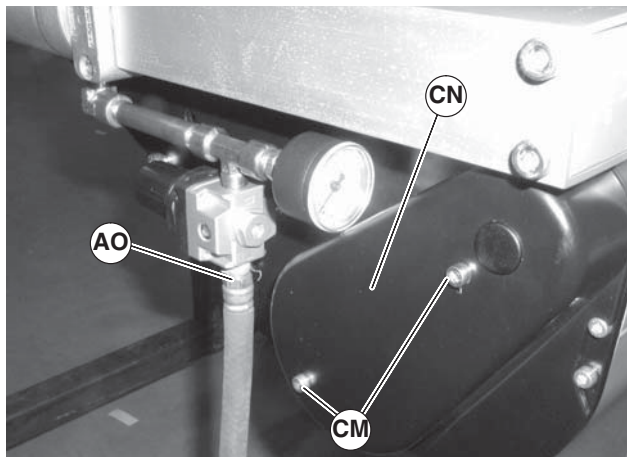

Figure 91

2. Remove screws (Figure 91, item CM) and cover (CN).
3. Loosen clamp screw (Figure 92, item CQ) and remove bearing collar (CR).

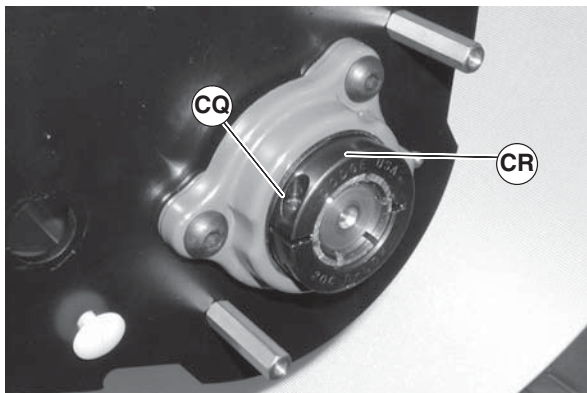

Figure 92

4. Remove the three (3) mounting screws (Figure 93, item CX).

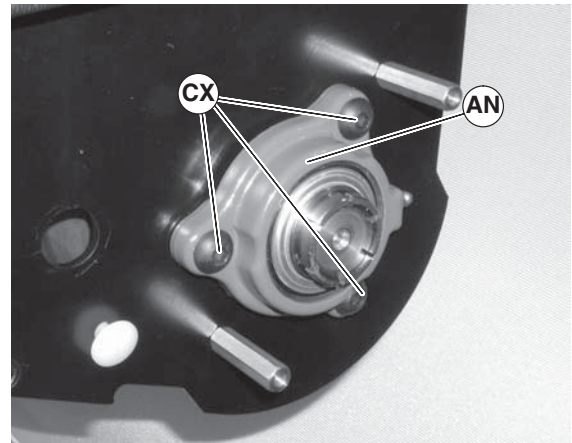

Figure 93

5. Remove and replace housing assembly (Figure 93, item AN).
6. Tighten three (3) mounting screws (Figure 93, item CX) to 200 in-lbs (22.5 N-m).
7. Reinstall bearing collar (Figure 92, item CR). Tighten clamp screw (CQ) to 95 in-lbs (11 N-m).
8. Reinstall cover (Figure 91, item CN). Tighten screws (CM) to 69 in-lbs (8 N-m).

C – Transfer Tail Bearing Replacement

The bearings in a 3200 Series Transfer Tail Pulley can not be removed. Replace the entire pulley assembly when worn.

Pulley Replacement

Idler Pulley

To replace the idler pulley, reverse the “Idler Pulley Removal” procedure on page 19.

Drive Pulley

To replace the drive pulley, reverse the “Drive Pulley Removal” procedure on page 24.

Transfer Tail Pulley

To replace the transfer tail pulley, reverse the “Transfer Tail Pulley Removal” procedure on page 20.

Service Parts

NOTE

For replacement parts other than those shown in this section, contact an authorized Dorner Service Center or the factory. Key Service Parts and Kits are identified by the Performance Parts Kits logo . Dorner recommends keeping these parts on hand.

Center Drive Assembly

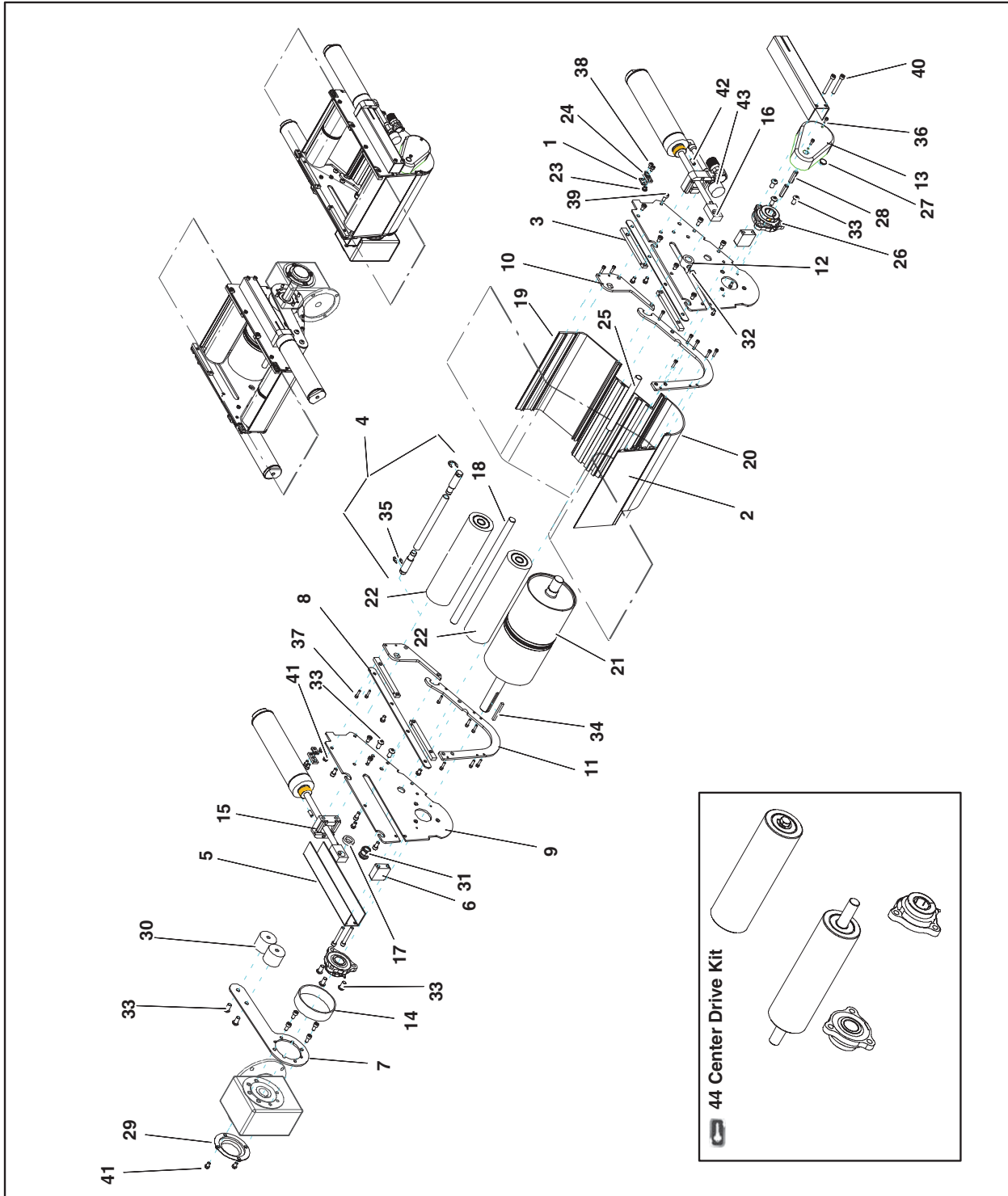

3200 Series Center Drive Flat Belt Conveyors

Service Parts

Item	Part Number	Description
1	200038	Cam Clamping Plate
2	See Table 1	Flat Guard
3	301088	Tail Clamping Bar
4	3227WW	Wand Assy for 3" Idler Roller
5	532419	Cylinder Channel Guard
6	301216	Cylinder Guard Mounting Block
7	301217	Torsion Arm Plate
8	301218	Side Plate Spacer
9	301219	Center Drive Side Plate
10	301220	End Roller Mounting Plate
11	301221	Horseshoe Guard Mount Plate
12	301222	Center Drive Tension Pulley Spacer
13	301278	Center Drive Bearing Guard
14	301281	Pipe Guard
15	301355	Cylinder Mounting Block
16	301356	Cylinder-Rod Mounting Block
17	301357	Tension Pulley Spacer
18	3242WW	Tension Pulley Axle Shaft
19	3243WW	Bottom End Guard
20	3244WW	Bottom Corner Guard
21	3287WW	6" Diameter Pulley
22	3290WW	3" Center Drive Pulley
23	200039P	Belt Tracking Cam
24	200341M	Cam Retaining Block
25	See Table 1	Inner Shaft Tube
26	802-138	3 Bolt Bearing
27	807-226	Snap Out Plastic Plug
28	807-1162	Hex Stand Off
29	807-1167	Gearhead Cover
30	812-061	Anti-rotation Bushing
31	824-331	1/2" EMT Steel Connector
32	825-160	1/4" BSPT Pipe Plug
33	911020M	Button Head Screw M10 x 20mm
34	912-111	Square Key
35	915-265	E Retaining Ring
36	920512M	Socket Head Screw M5 x 12mm
37	920520M	Socket Head Screw M5 x 20mm
38	920610M	Socket Head Screw M6 x 10mm
39	920816M	Socket Head Screw M8 x 16mm
40	920860M	Socket Head Screw M8 x 60mm
41	920892M	Low Head Screw M8 x 12mm
42	970820M	Cup Set Screw M8 x 20mm
43	301213	Pneumatic Tension Assy
44	32CD-WW	Center Drive Kit (includes items 4, 18, 22 and 26)

WW = Conveyor width reference: 04 – 60 in 02 increments

Conveyor Width	Item 2 – Flat Guard	Item 25 – Inner Shaft Tube
4"	300895-00374	301164
6"	300895-00599	301198-00209
8"	300895-00799	301198-00409
10	300895-00999	301198-00609
12	300895-01199	301198-00809
14	300895-01399	301198-01009
16	300895-01599	301198-01209
18	300895-01799	301198-01409
20	300895-01999	301198-01609
22	300895-02199	301198-01809
24	300895-02399	301198-02009
26	300895-02599	301198-02209
28	300895-02799	301198-02409
30	300895-02999	301198-02609
32	300895-03199	301198-02809
34	300895-03399	301198-03009
36	300895-03599	301198-03209
38	300895-03799	301198-03409
40	300895-03999	301198-03609
42	300895-04199	301198-03809
44	300895-04399	301198-04009
46	300895-04599	301198-04209
48	300895-04799	301198-04409
50	300895-04999	301198-04609
52	300895-05199	301198-04809
54	300895-05399	301198-05009
56	300895-05599	301198-05209
58	300895-05799	301198-05409
60	300895-05999	301198-05609

Service Parts

Center Drive Manual Tensioner

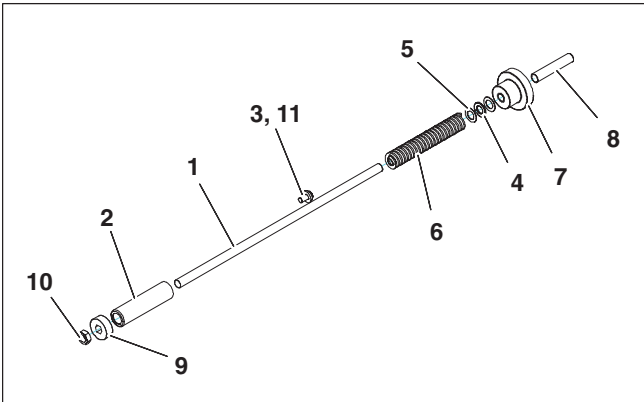

Item	Part Number	Description
1	301410	Threaded Rod 1/2" x 17" Long
2	3015 \overline{WW}	Spring Cage (04" through 24" Wide Conveyor)
	301524	Spring Cage (26" through 60" Wide Conveyor)
3	605280P	Hard Washer
4	802-139	Thrust Bearing Cage
5	802-140	Thrust Bearing Washer
6	807-1182	Spring - Blue (04" through 08" Wide Conveyor)
	807-1183	Spring - Red (10" through 12" Wide Conveyor)
	807-1184	Spring - Bronze (14" through 60" Wide Conveyor)
7	807-1185	Knurled Knob
8	807-1186	End Cap
9	807-1187	Threaded Plug
10	910-081	Hex Jam Nut 1/2"-20
11	920893M	Low Head Cap Screw M8 x 16mm
\overline{WW} = Conveyor width reference: 04 - 60 in 02 increments		

Center Drive 90° Industrial Gearmotors

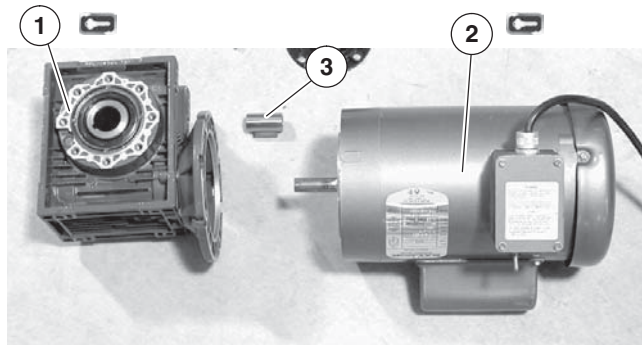

Item	Part No.	Part Description
1	32M008HH	Gear Reducer, 7.5:1 NEMA 140TC
	32M010HH	Gear Reducer, 10:1 NEMA 140TC
	32M015HH	Gear Reducer, 15:1 NEMA 140TC
	32M020HH	Gear Reducer, 20:1 NEMA 140TC
	32M025HH	Gear Reducer, 25:1 NEMA 140TC
	32M030HH	Gear Reducer, 30:1 NEMA 140TC
	32M040HH	Gear Reducer, 40:1 NEMA 140TC
	32M050HH	Gear Reducer, 50:1 NEMA 140TC
	32M060HH	Gear Reducer, 60:1 NEMA 56C
	32M080HH	Gear Reducer, 80:1 NEMA 56C
	32M100HH	Gear Reducer, 100:1 NEMA 56C
2	62MS411FN	Motor, 0.25hp (0.19Kw), 115/230 Volts, 60 Hz, 1-Phase
	62MH411	Motor, 0.5hp (0.37Kw), 115/230 Volts, 60Hz, 1-Phase
	62MH423	Motor, 0.5hp (0.37Kw) 208-230/460 Volts, 60Hz, 3 Phase
	32MHH423FN10	Motor, 1 hp (0.75Kw), 230 Volts, 3 Phase
	32MS423EN	Motor, 0.5hp (0.37Kw), 230 Volts, 3 Phase Inverter Duty
	32MHH423EN10	Motor, 1hp (0.75Kw), 230 Volts, 3 Phase Inverter Duty
	32MHH423EN15	Motor, 1.5hp (1.1Kw), 230 Volts, 3 Phase Inverter Duty
	32MHH423FN15	Motor, 1.5hp (1.1Kw), 230 Volts, 3 Phase
	62MHD9DEN	Motor, 0.5hp (0.37Kw), 90 Volts DC,
	62MHD9DEN75	Motor, 0.75hp (0.56Kw), 90 Volts DC,
	32MHH423EN20	Motor, 2.0hp (1.5Kw), 230 Volts, 3 Phase Inverter Duty
	32MHH423FN20	Motor, 2.0hp (1.5Kw), 230 Volts, 3 Phase
	32MHH411EC10	Motor, 1.0hp (0.75Kw), 115 Volts, Integrated Controller
	32MHH411EC15	Motor, 0.5hp (0.37Kw), 115 Volts, Integrated Controller
	3	820-329

Service Parts

Transfer Tail Assembly

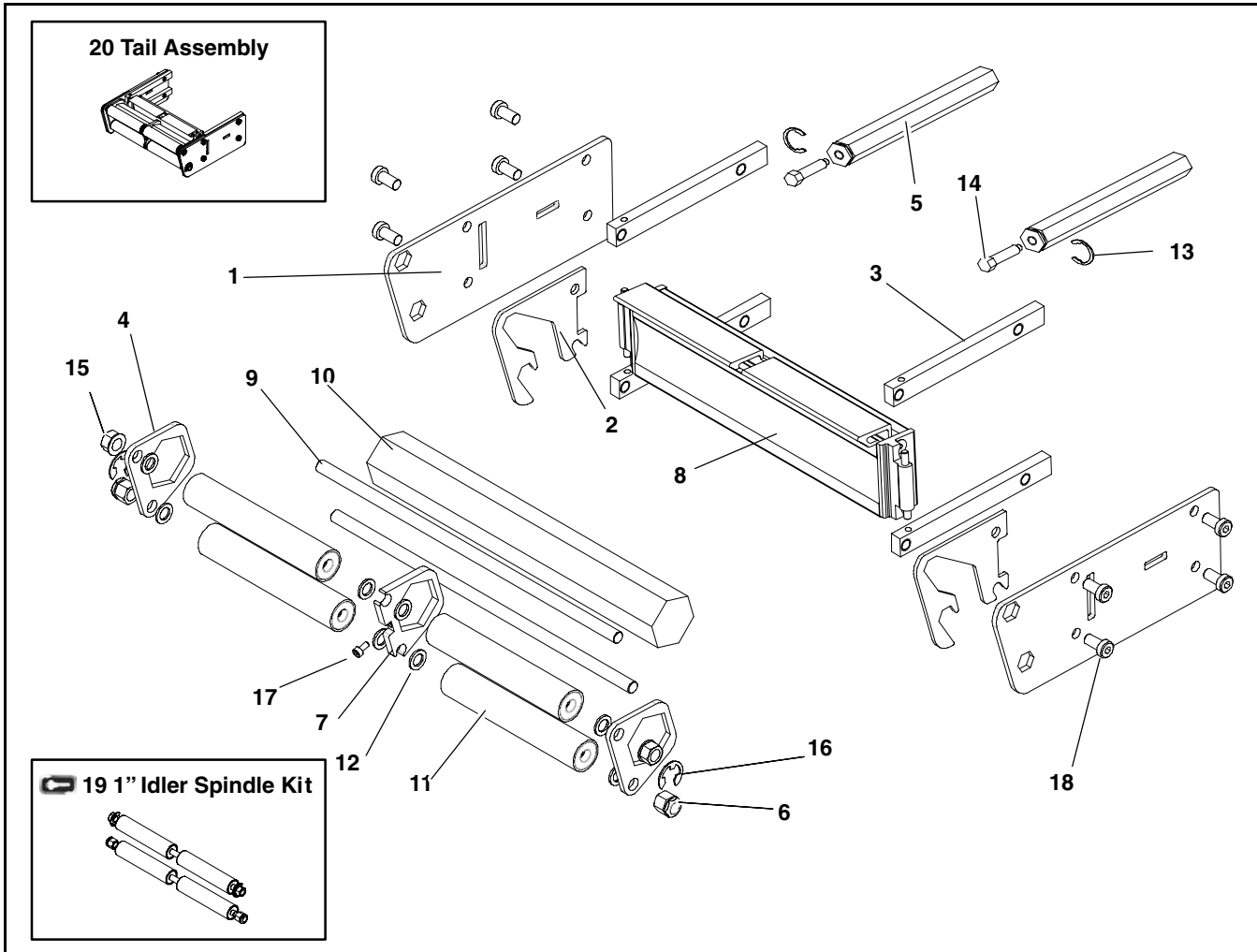

Item	Part Number	Description
1	301082	Nosebar Cover Plate
2	301084	1" Inner Tail Plate
3	301088	Tail Bar Clamp Transfer
4	301090	Tail Support Plate
5	301196	Hex Tension Tracking Shaft
6	301352	Nut, E-ring, Brace
7	301354	Inner Transfer Tail Support Plate
8	3202WW	Tail Articulation Bar
9	3217WW	1" Idler Tail Axle Shaft
10	3219WW	Support Bar
11	3237WW	Transfer Tail Roller – (Qty. = 4 for 04–24 Wide, 8 for 26–48 Wide)
12	807-1136	Washer
13	807-1151	Retaining Ring

Item	Part Number	Description
14	807-1152	Hex Head Cap Screw M6 x 20mm
15	910-203	3/8" Hex Nut
16	915-319	Retaining Ring
17	920408M	Hex Head Cap Screw M4 x 8mm
18	920893M	Low Head Socket Screw M8 x 16mm
19	32T1-WW	1" Idler Spindle Kit (includes items 6, 9, 11, 12, 15 and 16)
20	32TT1-WW	Tail Assembly (includes items 1 through 4, 6 through 12, 15 through 18)

WW = Conveyor width reference: 04 – 48 in 02 increments

Idler End Assembly

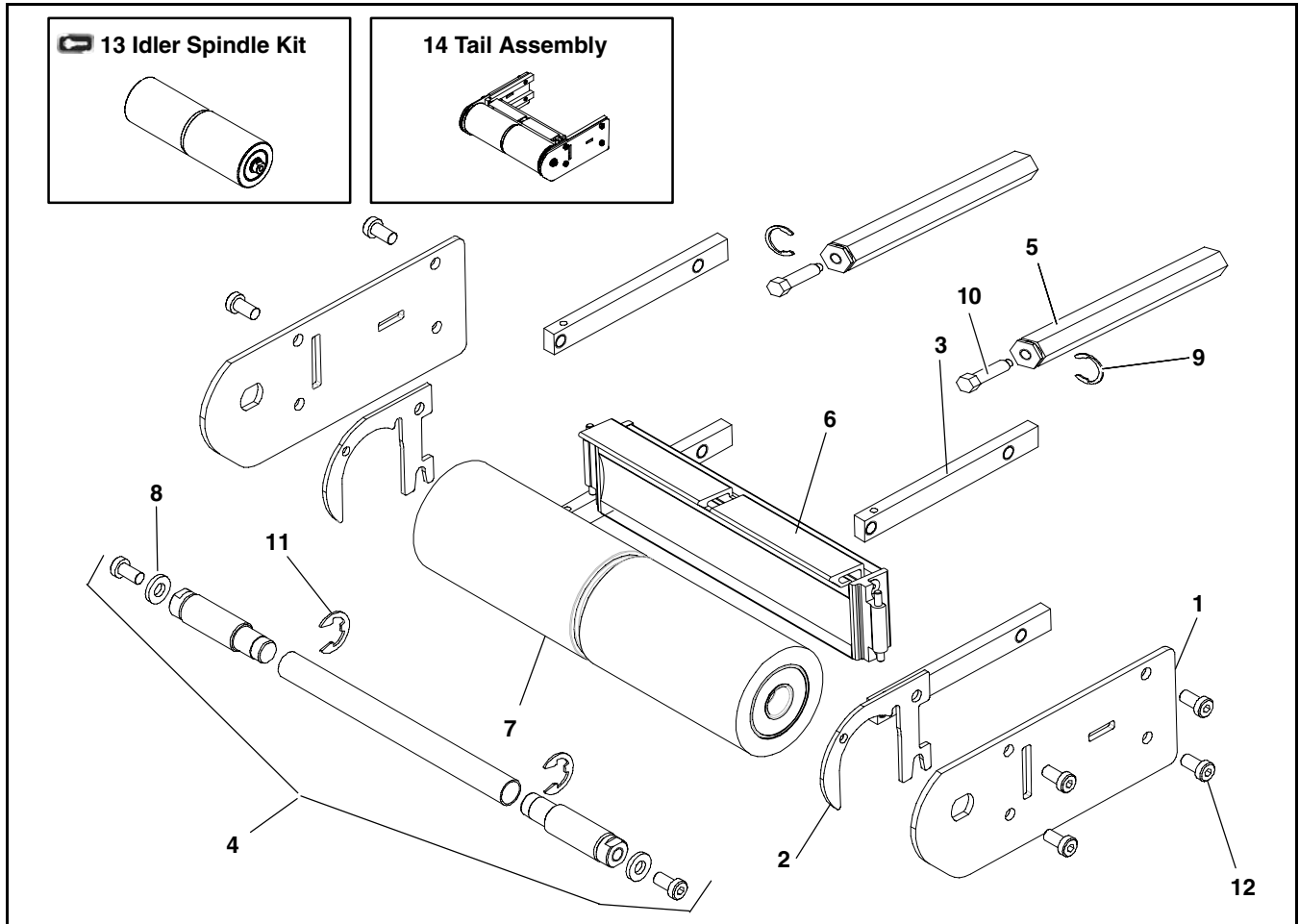

Item	Part Number	Description
1	301049	Idler Cover Plate
2	301083	Inner 3" Tail Plate
3	301088	Tail Bar Clamp
4	3282WW	Idler Spindle Wand Assembly (includes items 8 and 11)
5	301196	Hex Tension Tracking Shaft
6	3202WW	Tail Articulation Bar
7	3289WW	3" Idler Pulley
8	605280P	Hard Washer
9	807-1151	Tracking Shaft Retaining Ring
10	807-1152	Hex Head Cap Screw M6 x 20mm
11	915-235	Stub Shaft Retaining Ring
12	920893M	Low Head Socket Screw M8 x 16mm
13	32T3-WW	Idler Spindle Kit (includes items 4 and 7)
14	32TT3-WW	Tail Assembly (including items 1 through 4, 6, 7 and 12)

WW = Conveyor width reference: 04 – 48 in 02 increments

Service Parts

Frame Assembly

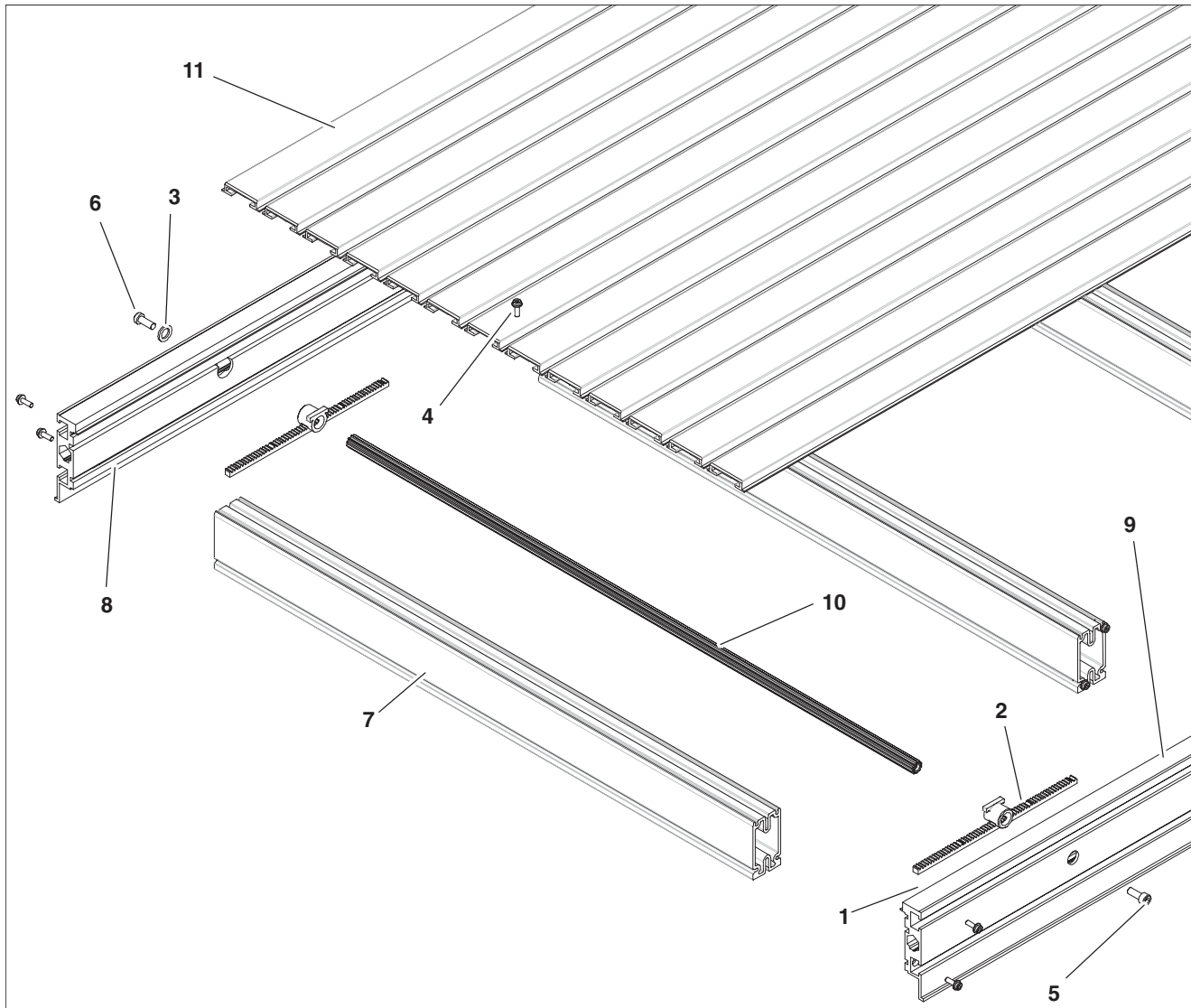

Item	Part Number	Description
1	240420	Rack Gear
2	301091	Pinion Bearing
3	605279P	Washer
4	920484M	Flange Torx Screw M4 x 16mm
5	920616M	Socket Head Screw M6 x 16mm
6	920693M	Low Head Socket Screw M6 x 16mm
7	3245WW	Cross Support Rail
8	301041-LLLLL	RH Side Rail
9	301042-LLLLL	LH Side Rail
10	3229WW	Pinion
11		Bed Plate Rail

WW = Conveyor width reference: 04 – 48 in 02 increments
 LLLLL = Frame Length (see Bed Plate & Frame Formulas) in 02 increments

Item 11: Bed Plate Rail	
Width	Part Number
2" (54mm)	300888-LLLLL
4" (102mm)	300889-LLLLL
6" (152mm)	300890-LLLLL

LLLLL = Bed Plate Length (see Bed Plate & Frame Formulas on the next page)

Item 11: Bed Plate Rail	
Width	Part Number
1.75" (mm)	300887-LLLLL

Bed Plate and Frame Formulas

Bed Plate LLLLL = Frame LLLLL – 00013
 Frame LLLLL = Conveyor Length LLLL X 12 – Tail Adder
 # of Sections of Conveyor
 Tail Adder = 00600 for each Tension End
 00425 for each Non-Tension End

Width	Bed Plate Configuration												
4"								1.75"					
6"								4"					
8"								6"					
10"							2"	4"	2"				
12"							2"	6"	2"				
14"							4"	4"	4"				
16"							4"	6"	4"				
18"							6"	4"	6"				
20"							6"	6"	6"				
22"					4"	4"	4"	4"	4"				
24"					4"	4"	6"	4"	4"				
26"					6"	4"	4"	4"	6"				
28"					6"	4"	6"	4"	6"				
30"					6"	6"	4"	6"	6"				
32"					6"	6"	6"	6"	6"				
34"				4"	4"	6"	4"	6"	4"	4"			
36"				4"	4"	6"	6"	6"	4"	4"			
38"				4"	6"	6"	4"	6"	6"	4"			
40"				4"	6"	6"	6"	6"	6"	4"			
42"				6"	6"	6"	4"	6"	6"	6"			
44"				6"	6"	6"	6"	6"	6"	6"			
46"			4"	4"	6"	6"	4"	6"	6"	4"	4"		
48"			4"	4"	6"	6"	6"	6"	6"	4"	4"		
50"			4"	6"	6"	6"	4"	6"	6"	6"	4"		
52"			4"	6"	6"	6"	6"	6"	6"	6"	4"		
54"			6"	6"	6"	6"	4"	6"	6"	6"	6"		
56"			6"	6"	6"	6"	6"	6"	6"	6"	6"		
58"		4"	4"	6"	6"	6"	4"	6"	6"	6"	4"	4"	
60"		4"	4"	6"	6"	6"	6"	6"	6"	6"	4"	4"	
62"		4"	6"	6"	6"	6"	4"	6"	6"	6"	6"	4"	
64"		4"	6"	6"	6"	6"	6"	6"	6"	6"	6"	4"	
66"		6"	6"	6"	6"	6"	4"	6"	6"	6"	6"	6"	
68"		6"	6"	6"	6"	6"	6"	6"	6"	6"	6"	6"	
70"	4"	4"	6"	6"	6"	6"	4"	6"	6"	6"	6"	4"	4"
72"	4"	4"	6"	6"	6"	6"	6"	6"	6"	6"	6"	4"	4"

Service Parts

-04 3" (76 mm) Aluminum Side

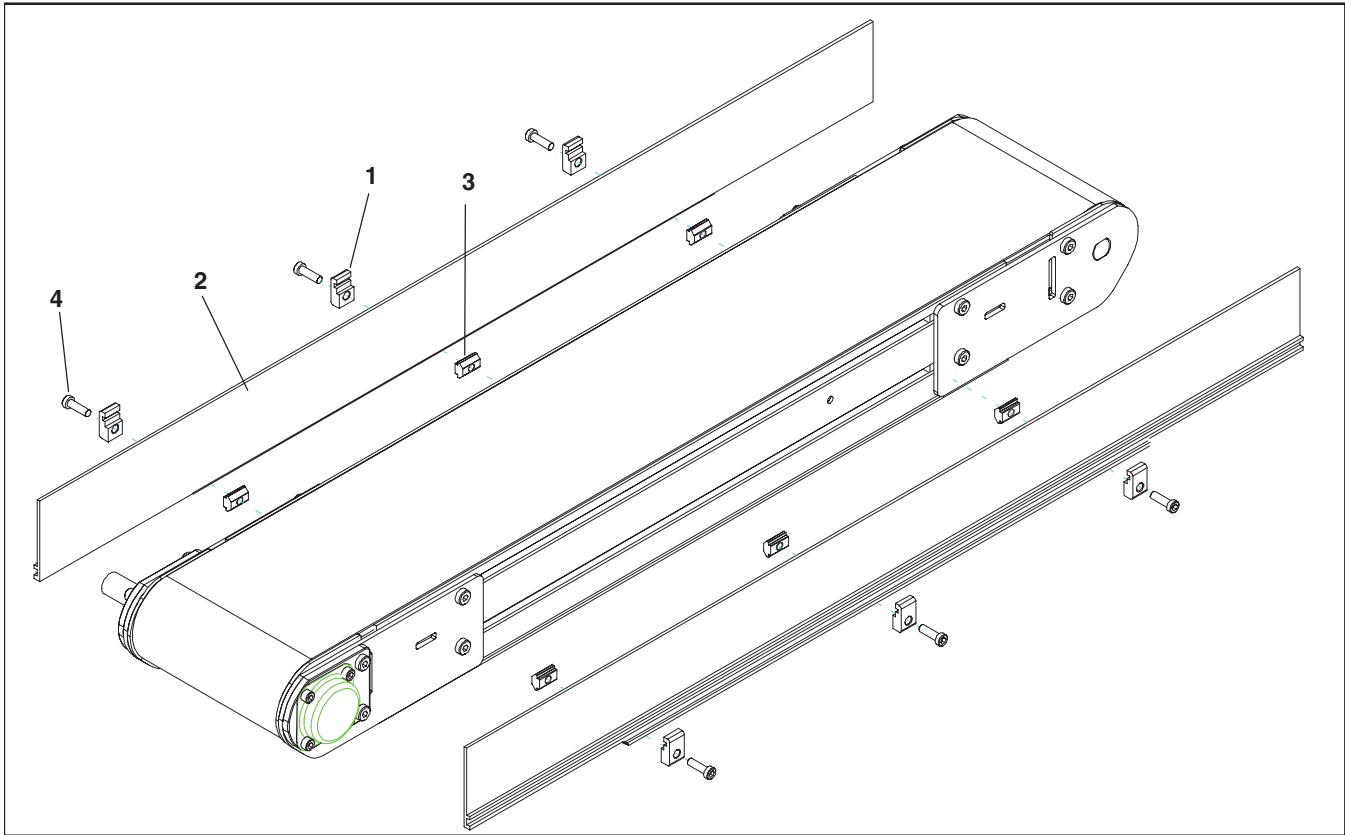

Item	Part Number	Description
1	200121	Guide Retaining Clip
2	380400-LLLLL (see Formulas)	3200 Guide 3" (76mm) HS
3	639971M	Single Drop-in Tee Bar
4	920694M	Socket Head Screw M6 x 20mm

Length Formulas

$$LLLLL = \frac{(\text{Conveyor Length } XXXX) \times 12 - \text{Tail Factor}}{\# \text{ of Sections of Conveyor}}$$

Tail Factor = 00000	for center drive with transfer tail both ends
00100	for end drive with one transfer tail
00200	for end drive and center drives with standard tails
00325	for All Cleated Conveyors

$$\# \text{ of Conveyor Sections} = \frac{(\text{Conveyor Length } XXXX - 0100)}{1200}$$

XXXX = Conveyor Length (XX.XX ft)

Example

17'4" End Drive Conveyor with Standard Tails

Conveyor Length = 1733

Tail Factor = 00200

$$\# \text{ of Sections (round up)} = \frac{(1733 - 0100)}{1200} = 1.36 = 2 \text{ Sections}$$

$$LLLLL = \frac{(1733 \times 12) - 00200}{2} = 10298$$

-05 1.5" (38 mm) Aluminum Side

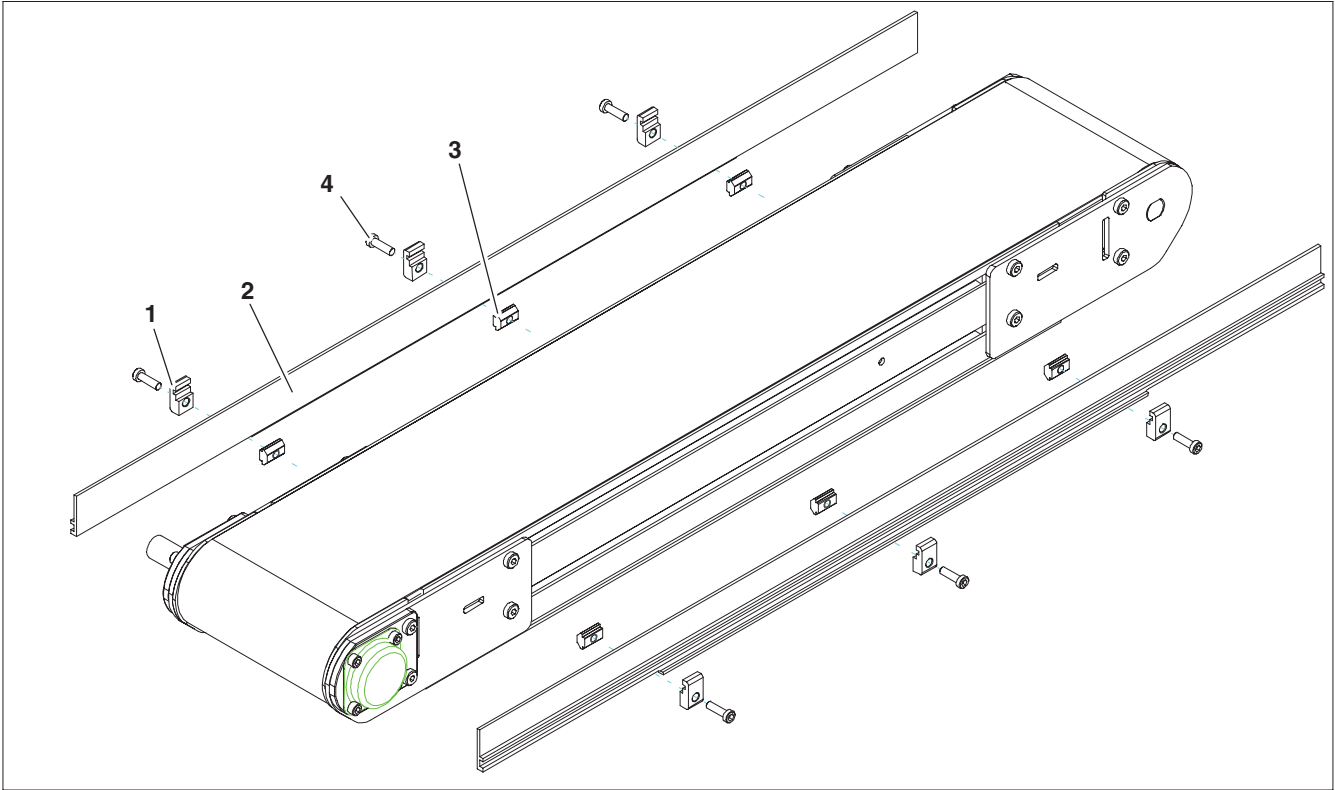

Item	Part Number	Description
1	200121	Guide Retaining Clip
2	380500-LLLLL (see Formulas)	3200 Guide, 0.5" (13mm) HS
3	639971M	Single Drop-in Tee Bar
4	920694M	Socket Head Screw M6 x 20mm

Length Formulas

$$LLLLL = \frac{(\text{Conveyor Length } XXXX) \times 12 - \text{Tail Factor}}{\# \text{ of Sections of Conveyor}}$$

Tail Factor =	00000	for center drive with transfer tail both ends
	00100	for end drive with one transfer tail
	00200	for end drive and center drives with standard tails
	00325	for All Cleated Conveyors

$$\# \text{ of Conveyor Sections} = \frac{(\text{Conveyor Length } XXXX - 0100)}{1200}$$

XXXX = Conveyor Length (XX.XX ft)

Example

17'4" End Drive Conveyor with Standard Tails

Conveyor Length = 1733

Tail Factor = 00200

$$\# \text{ of Sections (round up)} = \frac{(1733 - 0100)}{1200} = 1.36 = 2 \text{ Sections}$$

$$LLLLL = \frac{(1733 \times 12) - 00200}{2} = 10298$$

Service Parts

-07 Low to Side Wiper

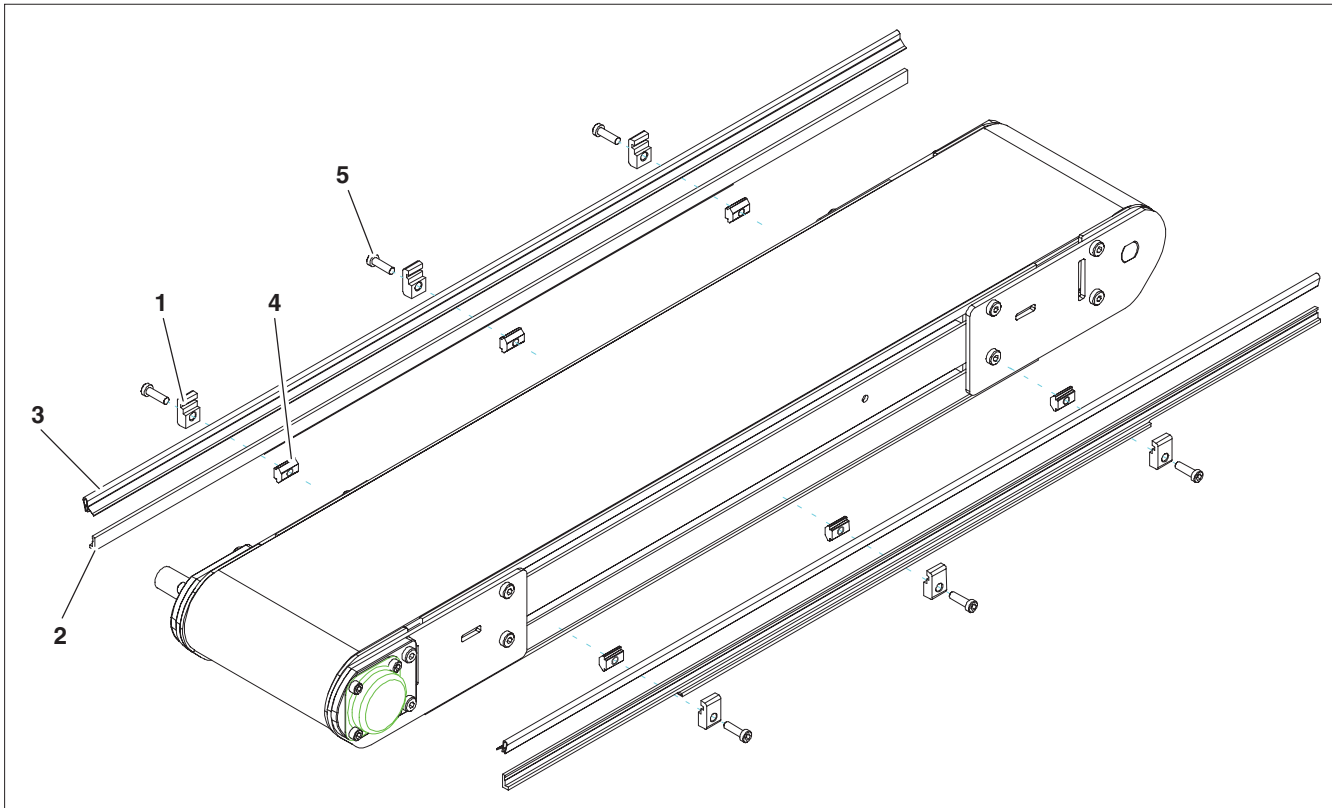

Item	Part Number	Description
1	200121	Guide Retaining Clip
2	380900-LLLLL (see Formulas)	3200 Guide, 0.5" (13mm) HS
3	41-00-24	Side Wiper Nylatron (per foot)
4	639971M	Single Drop-in Tee Bar
5	920694M	Socket Head Screw M6 x 20mm

Length Formulas

$$LLLLL = \frac{(\text{Conveyor Length } XXXX) \times 12 - \text{Tail Factor}}{\# \text{ of Sections of Conveyor}}$$

Tail Factor = 00000	for center drive with transfer tail both ends
00100	for end drive with one transfer tail
00200	for end drive and center drives with standard tails
00325	for All Cleated Conveyors

$$\# \text{ of Conveyor Sections} = \frac{(\text{Conveyor Length } XXXX - 0100)}{1200}$$

XXXX = Conveyor Length (XX.XX ft)

Example

17'4" End Drive Conveyor with Standard Tails

Conveyor Length = 1733

Tail Factor = 00200

$$\# \text{ of Sections (round up)} = \frac{(1733 - 0100)}{1200} = 1.36 = 2 \text{ Sections}$$

$$LLLLL = \frac{(1733 \times 12) - 00200}{2} = 10298$$

-09 Low to High Side

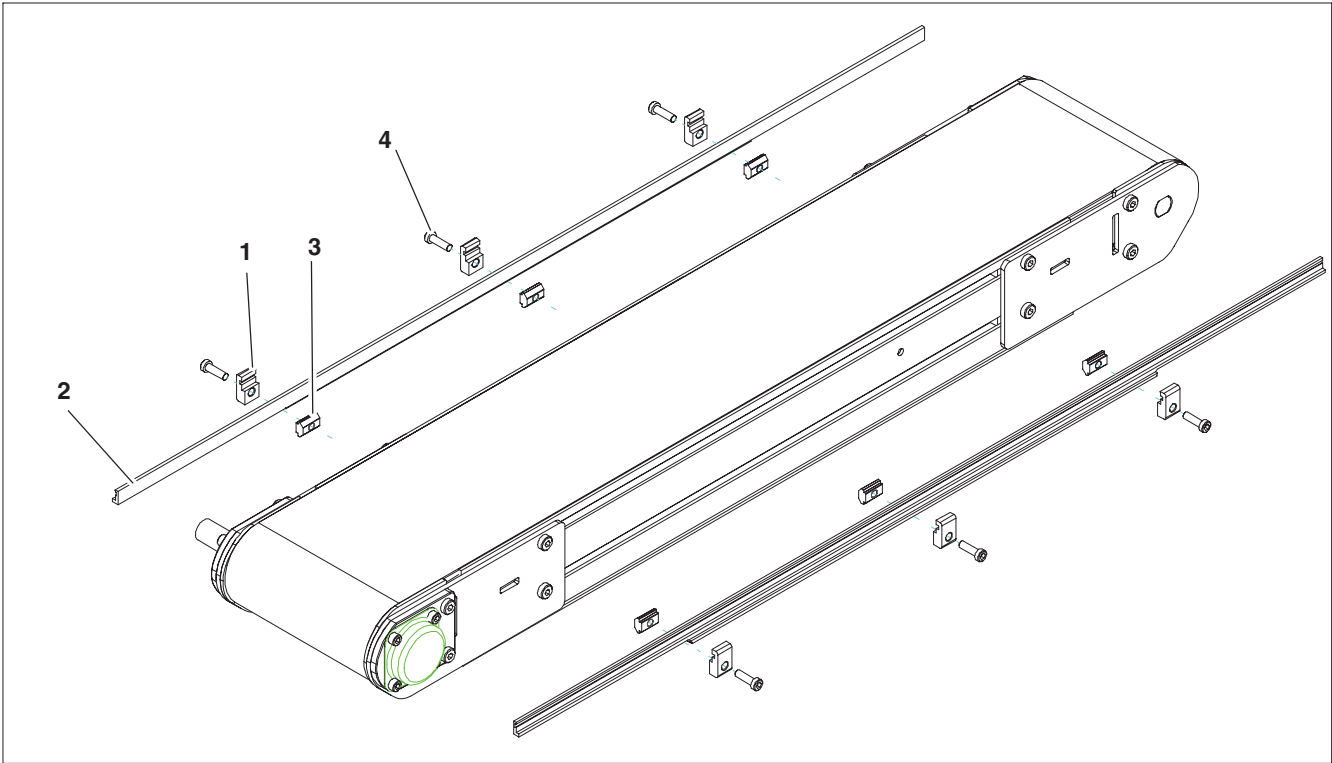

Item	Part Number	Description
1	200121	Guide Retaining Clip
2	380900-LLLLL (see Formulas)	2200 Guide, 0.5" (13mm) HS
3	639971M	Single Drop-in Tee Bar
4	920694M	Socket Head Screw M6 x 20mm

Length Formulas

$$\text{LLLLL} = \frac{(\text{Conveyor Length XXXX}) \times 12 - \text{Tail Factor}}{\text{\# of Sections of Conveyor}}$$

Tail Factor = 00000	for center drive with transfer tail both ends
00100	for end drive with one transfer tail
00200	for end drive and center drives with standard tails
00325	for All Cleated Conveyors

$$\text{\# of Conveyor Sections} = \frac{(\text{Conveyor Length XXXX} - 0100)}{1200}$$

XXXX = Conveyor Length (XX.XX ft)

Example

17'4" End Drive Conveyor with Standard Tails

Conveyor Length = 1733

Tail Factor = 00200

$$\text{\# of Sections (round up)} = \frac{(1733 - 0100)}{1200} = 1.36 = 2 \text{ Sections}$$

$$\text{LLLLL} = \frac{(1733 \times 12) - 00200}{2} = 10298$$

Service Parts

-10.5" (13 mm) Extruded Plastic

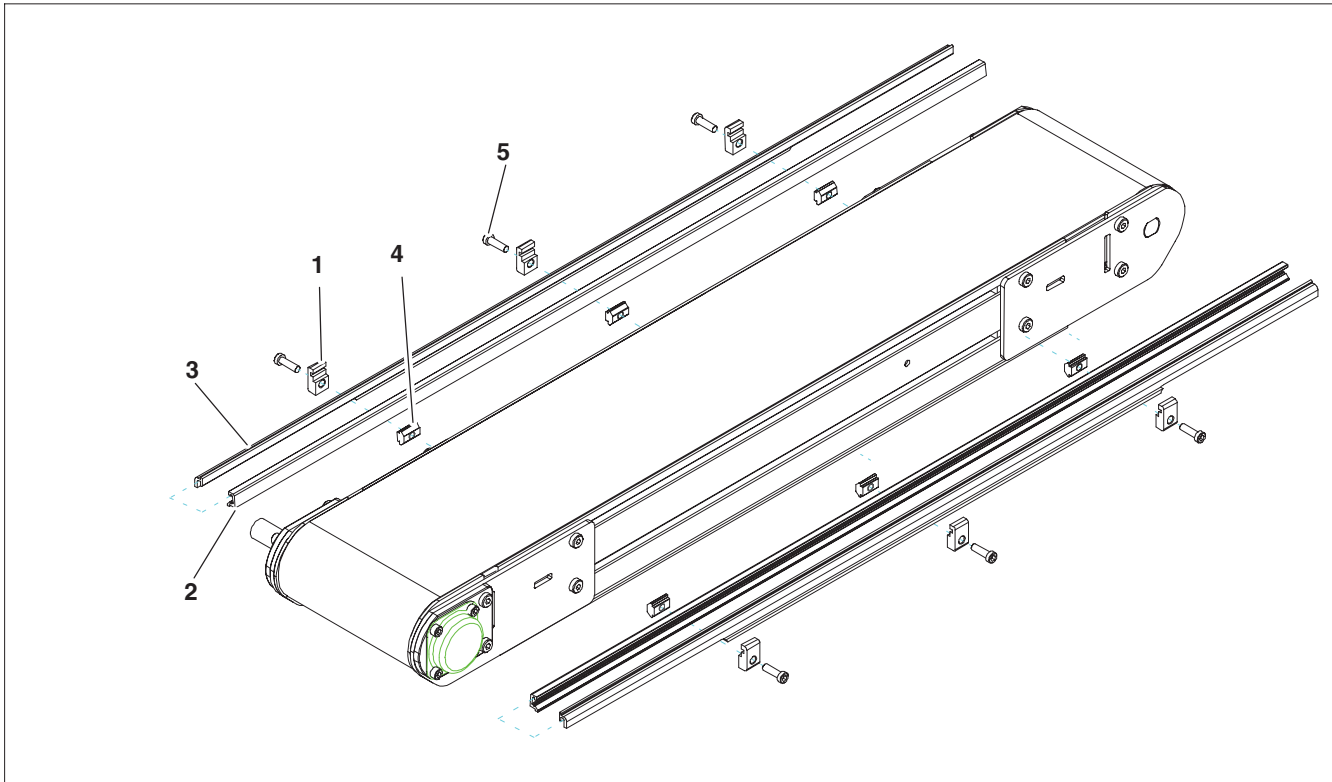

Item	Part Number	Description
1	200121	Guide Retaining Clip
2	200054P	Snap-On Guide (per foot)
3	3810000-LLLLL (see Formulas)	2200 Guide
4	639971M	Single Drop-in Tee Bar
5	920694M	Socket Head Screw M6 x 20mm

Length Formulas

$$LLLLL = \frac{(\text{Conveyor Length } XXXX) \times 12 - \text{Tail Factor}}{\# \text{ of Sections of Conveyor}}$$

Tail Factor =	00000	for center drive with transfer tail both ends
	00100	for end drive with one transfer tail
	00200	for end drive and center drives with standard tails
	00325	for All Cleated Conveyors

$$\# \text{ of Conveyor Sections} = \frac{(\text{Conveyor Length } XXXX - 0100)}{1200}$$

XXXX = Conveyor Length (XX.XX ft)

Example

17'4" End Drive Conveyor with Standard Tails

Conveyor Length = 1733

Tail Factor = 00200

$$\# \text{ of Sections (round up)} = \frac{(1733 - 0100)}{1200} = 1.36 = 2 \text{ Sections}$$

$$LLLLL = \frac{(1733 \times 12) - 00200}{2} = 10298$$

-13 Adjustable Guiding

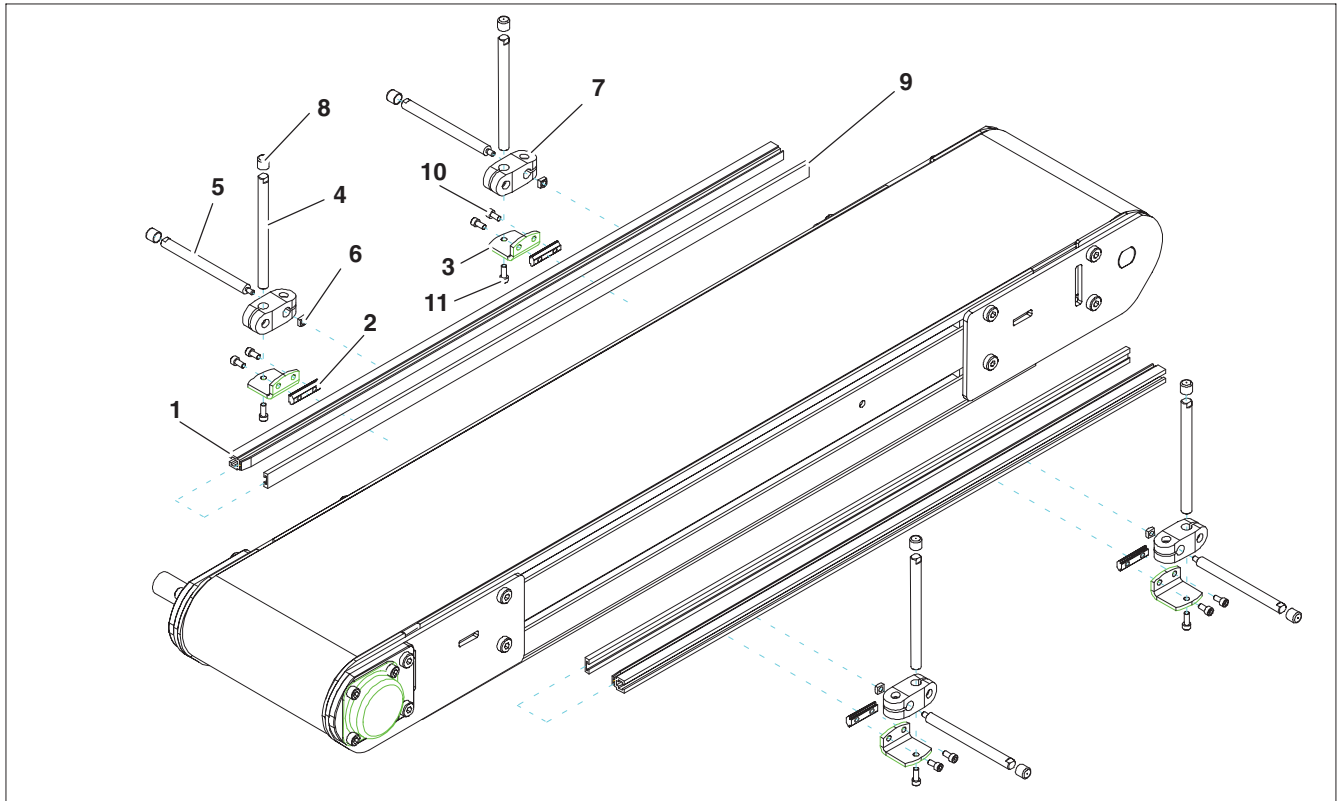

Item	Part Number	Description
1	202983	Aluminum Profile Guide 2' (610mm)
	202984	Aluminum Profile Guide 3' (914mm)
	202985	Aluminum Profile Guide 4' (1219mm)
	202986	Aluminum Profile Guide 5' (1524mm)
	202987	Aluminum Profile Guide 6' (1829mm)
	202988	Aluminum Profile Guide 7' (2134mm)
	202989	Aluminum Profile Guide 8' (2438mm)
	202990	Aluminum Profile Guide 9' (2743mm)
	202991	Aluminum Profile Guide 10' (3048mm)
	202992	Aluminum Profile Guide 11' (3353mm)
	202993	Aluminum Profile Guide 12' (3658mm)
	202994	Aluminum Profile Guide 13' (3962mm)
2	200830M	Drop-In Tee Bar
3	202004	Mounting Bracket
4	202027M	Guide Mounting Shaft Vertical
5	202028M	Guide Mounting Shaft Horizontal
6	674175MP	Square Nut
7	807-652	Cross Block
8	807-948	Vinyl Shaft Cap
9	614068P	Flat Extruded Guide (per foot)
10	920612M	Socket Head Screw M6 x 12mm
11	920616M	Socket Head Screw M6 x 16mm

Service Parts

Flared Side Guiding

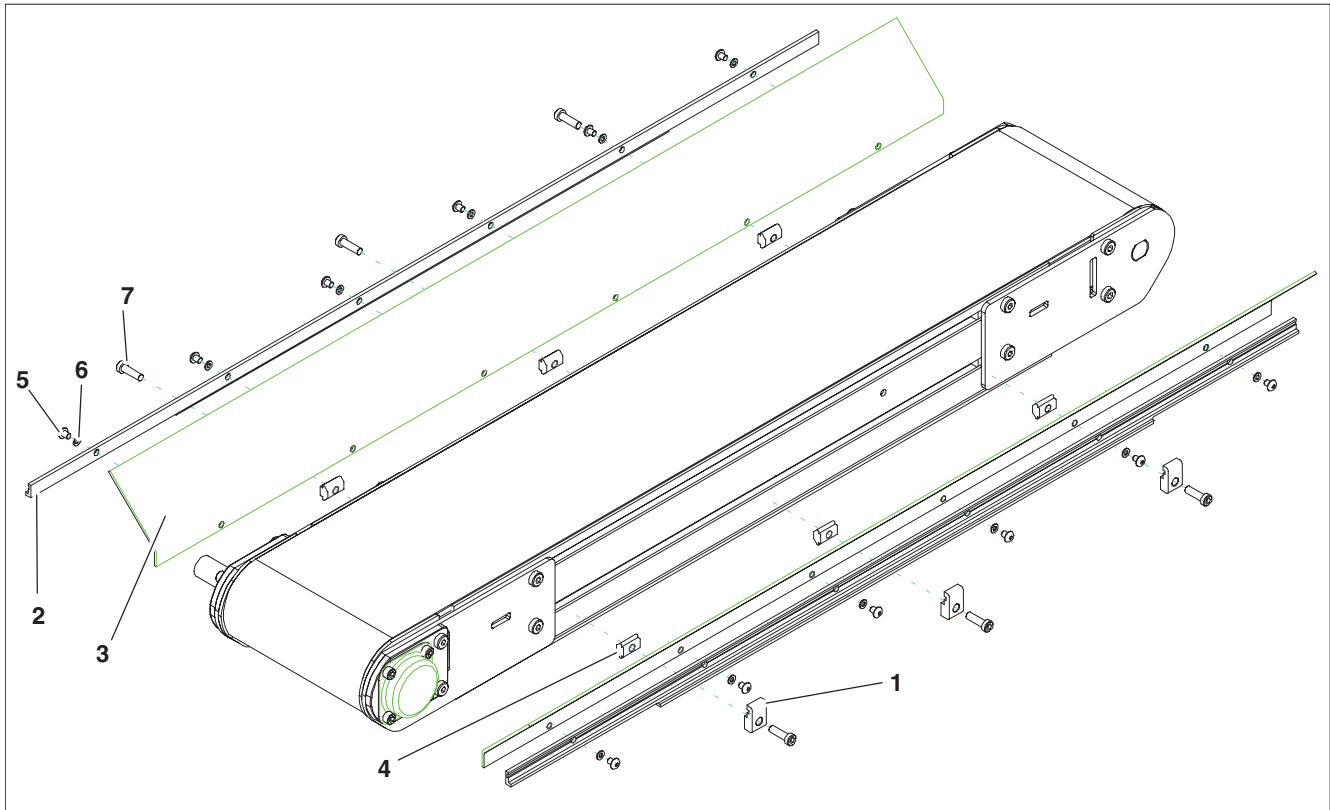

Item	Part Number	Description
1	200121	Guide Retaining Clip
2	202212	Side-Flare Mounting Guide 2' (610mm)
	202213	Side-Flare Mounting Guide 3' (914mm)
	202214	Side-Flare Mounting Guide 4' (1219mm)
	202215	Side-Flare Mounting Guide 5' (1524mm)
	202216	Side-Flare Mounting Guide 6' (1829mm)
3	202522M	Flared Guide 45° 2' (610mm)
	202523M	Flared Guide 45° 3' (914mm)
	202524M	Flared Guide 45° 4' (1219mm)
	202525M	Flared Guide 45° 5' (1524mm)
	202526M	Flared Guide 45° 6' (1829mm)
4	639971	Drop-In Tee Bar
5	910506M	Button Head Screw M5 x 6mm
6	911-512	Washer
7	920694M	Cap Low-Head Screw M6 x 20mm

Flat Belt Mounting Brackets

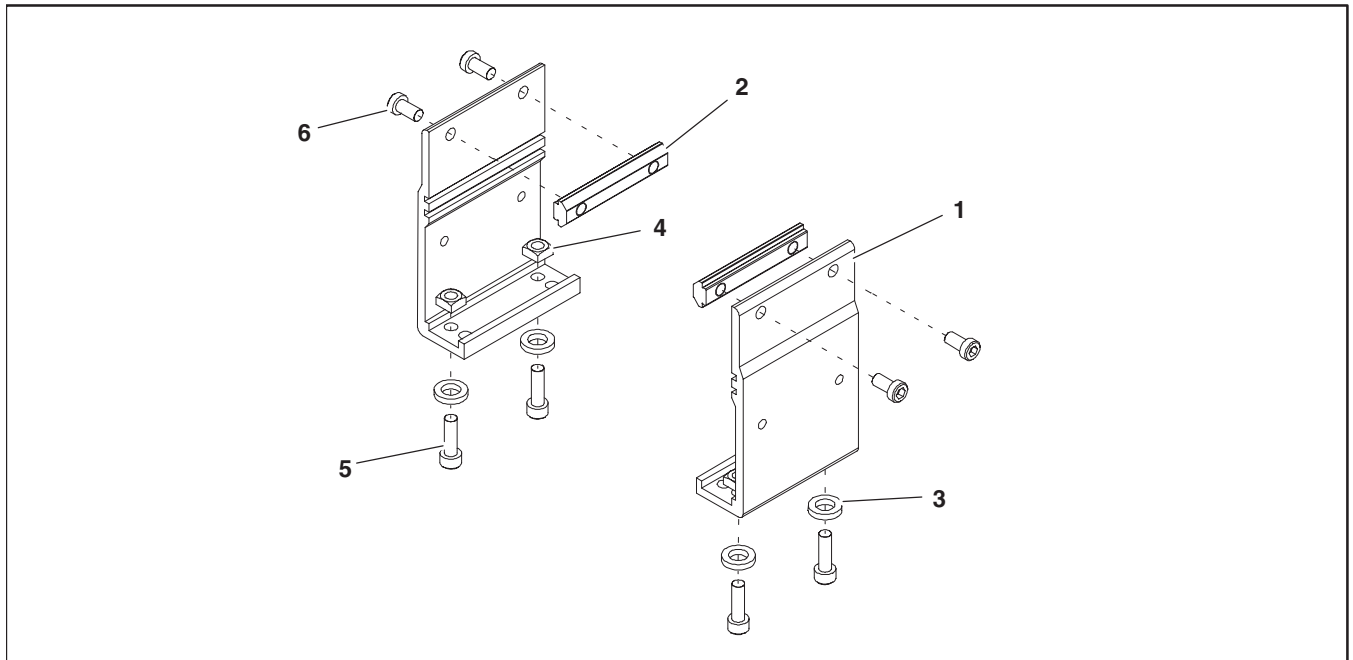

Item	Part Number	Description
1	240831	Stand Mount
2	300150M	Drop-In Tee Bar
3	605279P	Washer

Item	Part Number	Description
4	807-920	Square Nut M6 5mm x 10mm
5	920620M	Socket Head Screw M6 x 20mm
6	920692M	Socket Head Screw M6 x 12mm

Connecting Assembly without Stand Mount

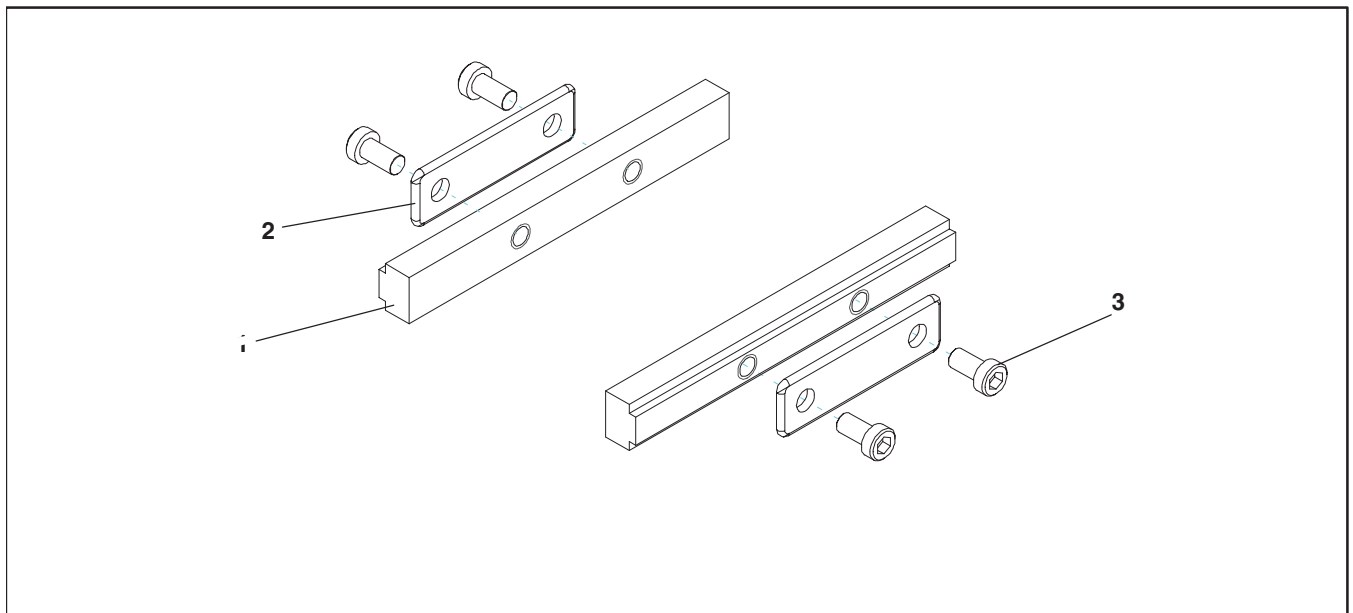

Item	Part Number	Description
1	240858	Frame Bar Connector
2	240859	Intermediate Clamp Plate
3	920692M	Socket Head Screw M6 x 12mm

Service Parts

Flat Belt Connecting Assembly with Stand Mount

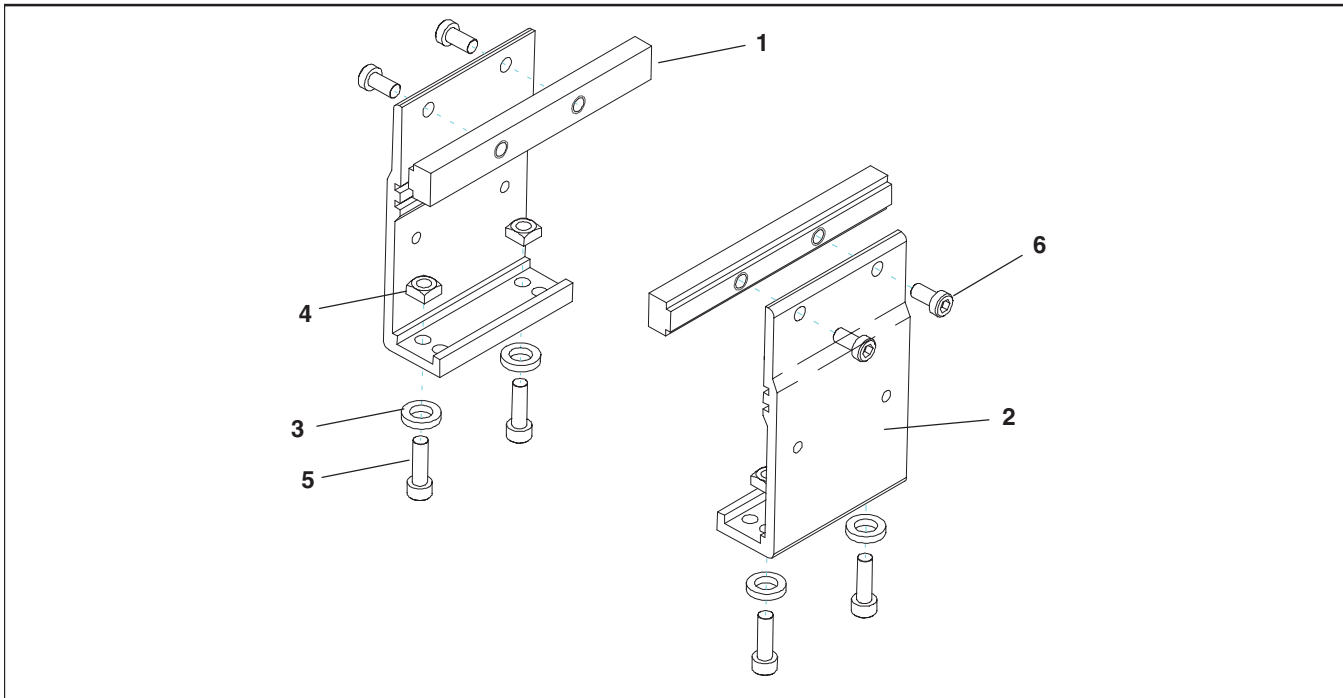

Item	Part Number	Description
1	240858	Frame Connector Bar
2	240837	Stand Mount Joint
3	605279P	Washer

Item	Part Number	Description
4	807-920	Square Nut M6 5mm x 10mm
5	920620M	Socket Head Screw M6 x 20mm
6	920692M	Socket Head Screw M6 x 12mm

4" (102 mm) to 6" (152 mm) Flat Belt Return Roller

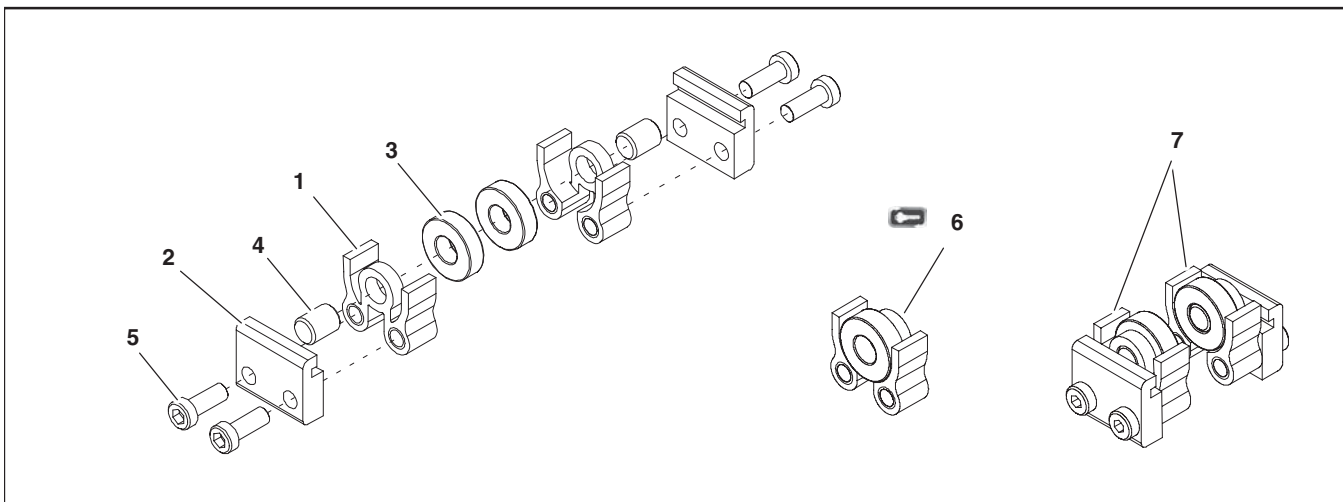

Item	Part Number	Description
1	240825	Return Roller Guard – Short
2	240827	Return Roller Clip
3	802-027	Bearing
4	913-100	Dowel Pin
5	920693M	Socket Low Head Screw M6 x 16mm
6	240840	Roller Assembly (Includes Items 1, 3 and 4)

Item	Part Number	Description
7	240830	4" (102mm) to 6" (152mm) Flat Belt Return Roller Assy

8" (203 mm) to 48" (1219 mm) Flat Belt Return Roller

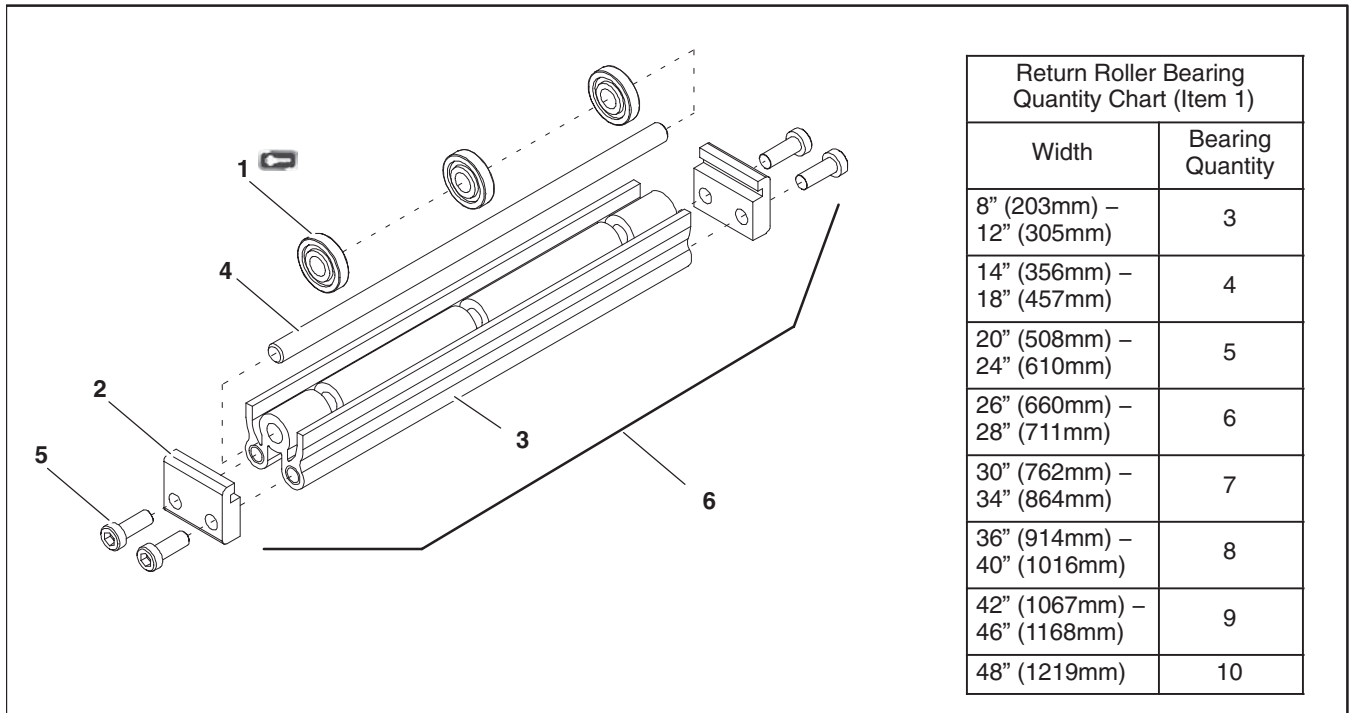

Width	Bearing Quantity
8" (203mm) – 12" (305mm)	3
14" (356mm) – 18" (457mm)	4
20" (508mm) – 24" (610mm)	5
26" (660mm) – 28" (711mm)	6
30" (762mm) – 34" (864mm)	7
36" (914mm) – 40" (1016mm)	8
42" (1067mm) – 46" (1168mm)	9
48" (1219mm)	10

Item	Part Number	Description
1	240826	Return Roller Bearing
2	240827	Return Roller Clip
3	2409 WW	Return Roller Guard
4	2410 WW	Return Roller Rod
5	920693M	Socket Head Screw M6 x 16mm
6	3249 WW	8" (203mm) – 48" (1219mm) Flat Belt Return Roller Assembly
WW = Conveyor width reference: 08 – 48 in 02 increments		

Service Parts

Conveyor Belt Part Number Configuration

Flat Belt Conveyor Model Number

3 T - WW LLLL / SBV*

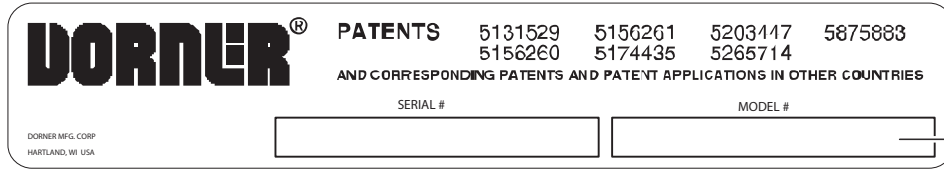

Figure 94

Flat Belt Part Number Configuration

Refer to Dorner patent plate (Figure 94). From the model number, determine tail type (“T”), width (“WW”), length (“LLLL”), splice type (“SS”) and belt type (“B”). Use data to configure belt part number as indicated below. * Add “V” for V-guided belts.

3 T - WW LLLL / SBV*

3 _ - _ _ (Fill In) / _

Return Policy

Returns must have prior written factory authorization or they will not be accepted. Items that are returned to Dorner without authorization will not be credited nor returned to the original sender. When calling for authorization, please have the following information ready for the Dorner factory representative or your local distributor:

1. Name and address of customer.
2. Dorner part number(s) of item(s) being returned.
3. Reason for return.
4. Customer's original order number used when ordering the item(s).
5. Dorner or distributor invoice number (if available, part serial number).

A representative will discuss action to be taken on the returned items and provide a Returned Goods Authorization (RMA) number for reference. RMA will automatically close 30 days after being issued. To get credit, items must be new and undamaged. There will be a return charge on all items returned for credit, where Dorner was not at fault. It is the customer's responsibility to prevent damage during return shipping. Damaged or modified items will not be accepted. The customer is responsible for return freight.

Conveyors and conveyor accessories

Standard catalog conveyors	30%
MPB, 7200, 7300 Series, cleated and specialty belt	50%
AquaGard & AquaPruf Series conveyors	non-returnable items
Engineered to order products	case by case
Drives and accessories	30%
Sanitary stand supports	non-returnable items

Parts

Standard stock parts	30%
Plastic chain, cleated and specialty belts	non-returnable items

Returns will not be accepted after 60 days from original invoice date. The return charge covers inspection, cleaning, disassembly, disposal and reissuing of components to inventory. If a replacement is needed prior to evaluation of returned item, a purchase order must be issued. Credit (if any) is issued only after return and evaluation is complete.

Dorner has representatives throughout the world. Contact Dorner for the name of your local representative. Our Customer Service Team will gladly help with your questions on Dorner products.

For a copy of Dorner's Warranty, contact factory, distributor, service center or visit our website at www.dorner.com.

For replacement parts, contact an authorized Dorner Service Center or the factory.



Dorner Mfg. Corp. reserves the right to change or discontinue products without notice. All products and services are covered in accordance with our standard warranty. All rights reserved. © Dorner Mfg. Corp. 2010

DORNER MFG. CORP.

975 Cottonwood Ave., PO Box 20
Hartland, WI 53029-0020 USA
TEL 1-800-397-8664 (USA)
FAX 1-800-369-2440 (USA)
Internet: www.dorner.com

Outside the USA:
TEL 1-262-367-7600
FAX 1-262-367-5827