



Single Post Support Stands & Pillar Supports

Installation, Maintenance & Parts Manual



DORNER MFG. CORP.
P.O. Box 20 • 975 Cottonwood Ave.
Hartland, WI 53029-0020 USA

INSIDE THE USA
TEL: 1-800-397-8664
FAX: 1-800-369-2440

OUTSIDE THE USA
TEL: 262-367-7600
FAX: 262-367-5827

For other service manuals visit our website at:
www.dorner.com/service_manuals.asp

Table of Contents

Introduction	2	Assembly - Pillar Support	7
Warnings - General Safety	3	Preventive Maintenance and Adjustment	9
Product Description	4	Required Tools	9
Specifications	4	Conveyor Height Adjustment.....	9
Installation	5	Conveyor Angle Adjustment.....	11
Requirements for Use of One Single Post Stand for Conveyor Support	5	Notes	13
Recommended Installation Sequence	5	Service Parts.....	14
Required Tools.....	5	Single Post/Pillar Support Stands.....	14
Assembly - Single Post Stand.....	5	Return Policy.....	16

Introduction

IMPORTANT

<i>Some illustrations may show guards removed. DO NOT operate equipment without guards.</i>

Upon receipt of shipment:

- Compare shipment with packing slip. Contact factory regarding discrepancies.
- Inspect packages for shipping damage. Contact carrier regarding damage.
- Accessories may be shipped loose. See accessory instructions for installation.

Dorner's Limited Warranty applies.

Dorner reserves the right to make changes at any time without notice or obligation.

Warnings - General Safety

⚠ WARNING

The safety alert symbol, black triangle with white exclamation, is used to alert you to potential personal injury hazards.

⚠ DANGER



Climbing, sitting, walking or riding on conveyor will cause severe injury.
KEEP OFF CONVEYORS.

⚠ WARNING



Exposed moving parts can cause severe injury.
LOCK OUT POWER before removing guards or performing maintenance.

⚠ DANGER

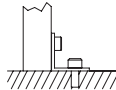

Pillar supports not anchored to floor will tip, causing severe injury or death.
PILLAR SUPPORT MUST BE ANCHORED TO FLOOR.

⚠ DANGER



DO NOT OPERATE CONVEYORS IN AN EXPLOSIVE ENVIRONMENT.

⚠ WARNING



Loosening stand height or angle adjustment screws may cause conveyor sections to drop down, causing severe injury.
SUPPORT CONVEYOR SECTIONS PRIOR TO LOOSENING STAND HEIGHT OR ANGLE ADJUSTMENT SCREWS.

⚠ WARNING



Dorner cannot control the physical installation and application of conveyors. Taking protective measures is the responsibility of the user.
When conveyors are used in conjunction with other equipment or as part of a multiple conveyor system, **CHECK FOR POTENTIAL PINCH POINTS** and other mechanical hazards before system start-up.

Product Description

Refer to Figure 1 for typical stand components.

A	Single Post Support Stand
B	Stand Mounting Bracket (with conveyor)
C	Height Adjustment Point
D	Angle Adjustment Point
E	Optional Diagonal Brace
F	Optional Casters

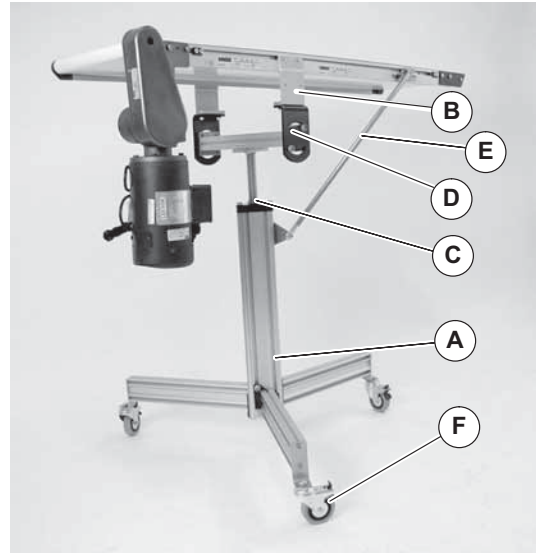
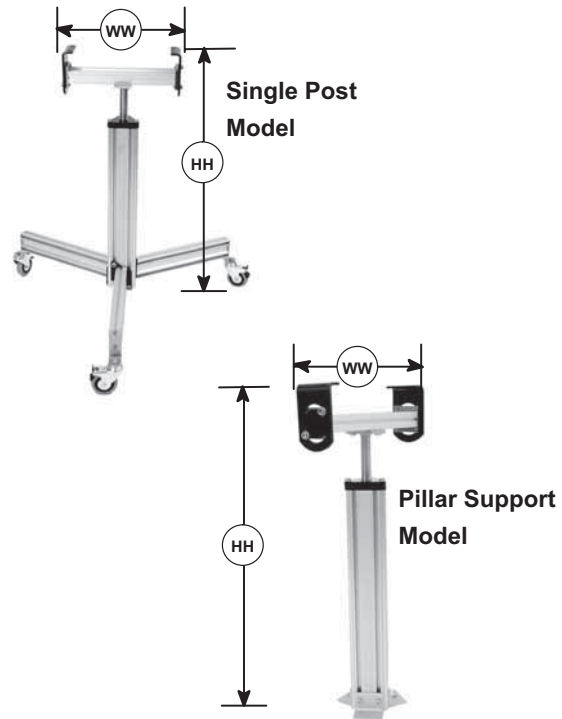
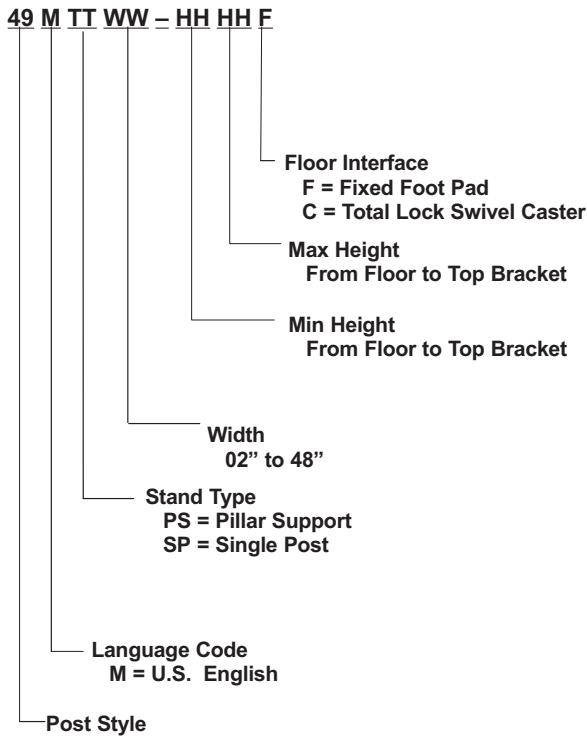

Figure 1

Specifications

Single Post and Pillar Support Stand Models



Example: 49MSP12– 23 33F

Single post style stand for a 12" wide conveyor with a minimum height of 23" and a maximum height of 33". It is equipped with fixed foot pads and has U.S. English documentation.

Requirements for Use of One Single Post Stand for Conveyor Support

⚠ WARNING

For maximum stability, install the conveyor on the stand so it is positioned and balanced as shown (at right).

DO NOT use with conveyors over 4ft (1219mm) long.

DO NOT use with conveyor equipped with a heavy load gearmotor bottom mounting package.

Failure to heed this warning could result in the conveyor being unstable and tipping over, resulting in equipment damage or personal injury.



Figure 2

⚠ DANGER

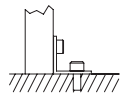

Pillar supports not anchored to floor will tip, causing severe injury or death.

PILLAR SUPPORT MUST BE ANCHORED TO FLOOR.

⚠ WARNING



Exposed moving parts can cause severe injury.

LOCK OUT POWER before removing guards or performing maintenance.

Recommended Installation Sequence (see Table of Contents for page number)

- Assemble stand(s)
- Attach stand(s) to conveyor (see Conveyor Installation, Maintenance & Parts Manual)
- Attach optional diagonal bracing (see Diagonal Brace Kit Manual)
- Adjust stand height and level (see Preventive Maintenance and Adjustment section, page 9)

Required Tools

- 6 mm Hex Key Wrench

Assembly - Single Post Stand

1. Typical components (Figure 3).

G	Trileg Post
H	Conveyor Mounting Bracket and Crossmember Tube Assembly
I	Base Leg Assembly(3x)
J	Hardware Pack, Single Post Stand

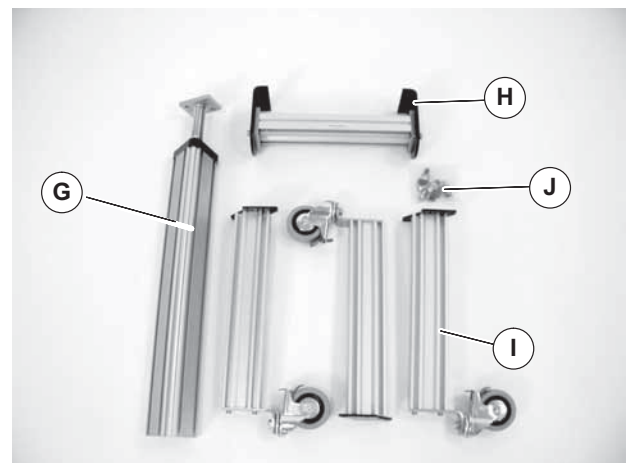

Figure 3

Installation

NOTE

Caster option shown. Foot pad option similar.

- Open hardware pack, single post stand (Figure 3, item J).
- Place a button screw (Figure 4, item L) through each hole in the end plate (N) of a leg tube (I). Attach a hex nut (M) to the screw. Leave a gap (O) between the nuts and end plate.

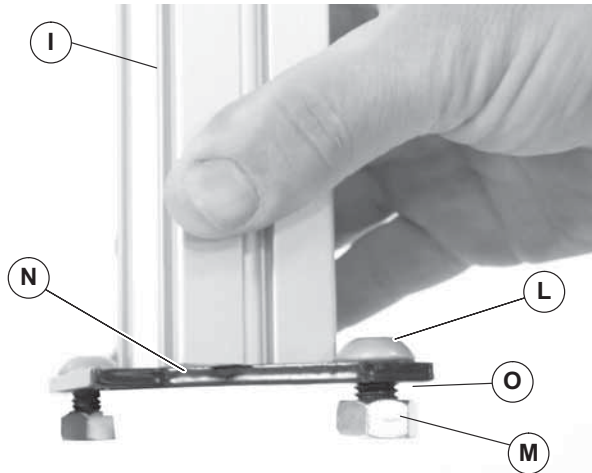

Figure 4

- Align the leg tube end plate hex nuts (Figure 5, item M) with the t-slots (P) on one side of the trileg post (G). Slide the hex nuts (M) into the T-slots (P).

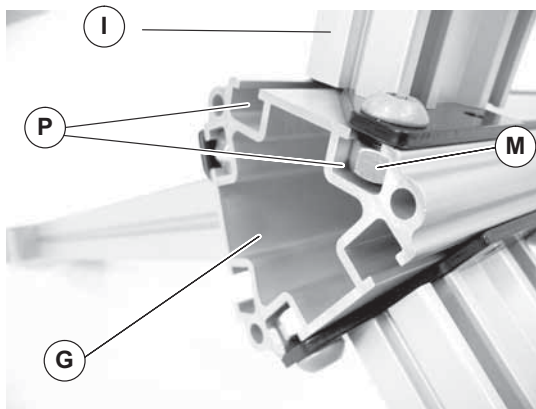

Figure 5

- Align bottom edge of the end plate (Figure 6, item N) with bottom edge of the trileg post (G).

WARNING



Failure to secure screws (Figure 6, item L) may cause conveyor sections to drop down, causing severe injury.
TIGHTEN ALL SCREWS (L) AFTER ADJUSTMENT.

- Tighten button screws (L) to 100 in-lb (11 N-m).

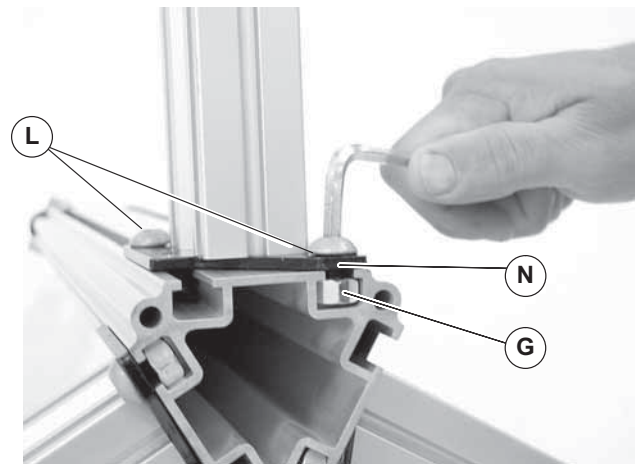

Figure 6

- Repeat steps 3 to 6 on other two legs.
- Position the conveyor mounting bracket and crossmember tube assembly (Figure 7, item H) so there is access to the underside t-slots (P) and hex nuts (M).

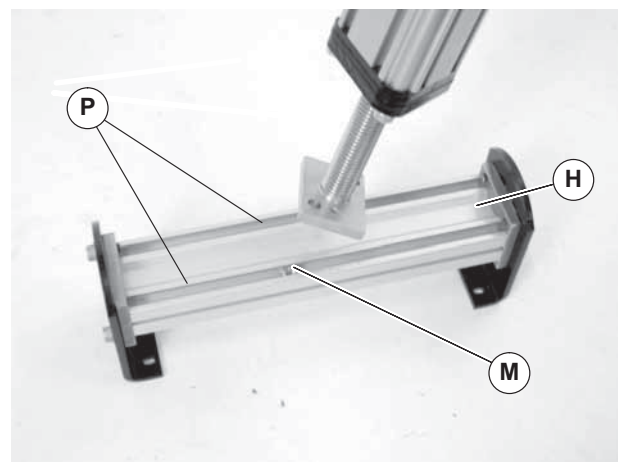

Figure 7

- Align the screw holes (Figure 8, item R) of the stand top screw end plate (Q) with the hex nuts in the t-slots in the crossmember tube (H).

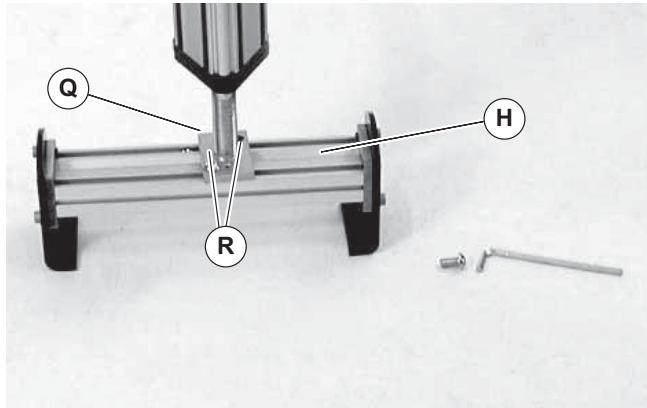

Figure 8

10. Attach the button screws to the hex nuts, do not tighten. Position the stand assembly up right.
11. To center the conveyor mounting bracket (Figure 8, item H), position the “Attach Here” sticker (Figure 9, item T) with the end plate (S) of the stand top screw assembly.



Figure 9

⚠ WARNING
<p>Failure to secure screws (Figure 9, item U) may cause conveyor sections to drop down, causing severe injury.</p> <p>TIGHTEN ALL SCREWS (U) AFTER ADJUSTMENT.</p>

12. Tighten button screws (Figure 9, item U) to 100 in-lb (11 N-m).

Assembly - Pillar Support

1. Typical components (Figure 10).

V	Trileg Post
W	Conveyor Mounting Bracket and Crossmember Tube assembly
X	Hardware Pack, Single Post Stand
Y	Stand Foot Bracket (3x)

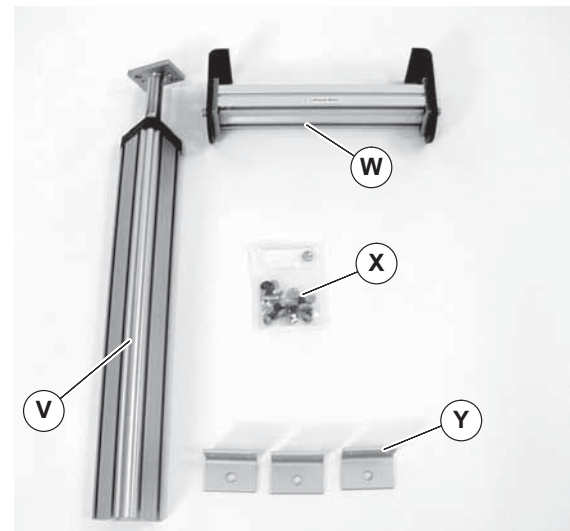

Figure 10

2. Open the hardware pack, single post stand (Figure 10, item X).
3. Place two socket screws (Figure 11, item Z) and nuts (AA) on the three stand foot brackets (Y). Do not tighten.

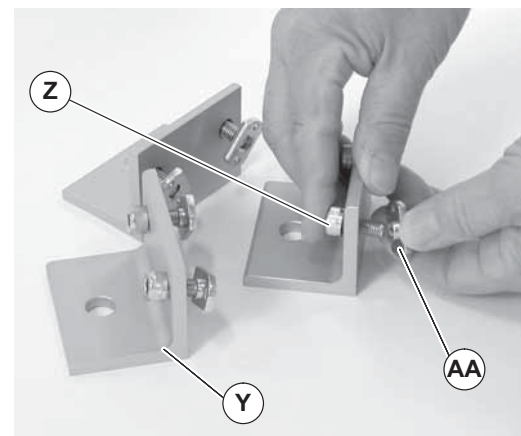

Figure 11

4. Align nuts (Figure 11, item AA) with t-slots (P) on one side of trileg post (V). Slide the foot bracket (Y) onto the post.

Installation

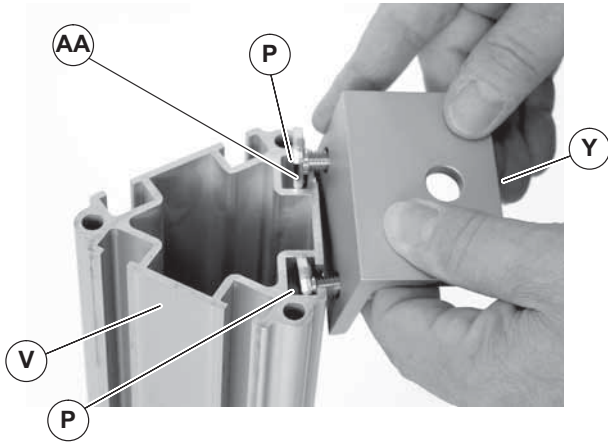

Figure 12

- Align the foot bracket edge (Figure 12, item Y) with the bottom edge of the trileg post (V).

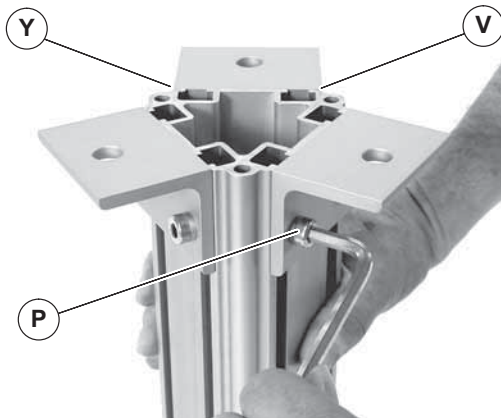

Figure 13

⚠ WARNING
<p>Failure to secure screws (Figure 12, item P) may cause conveyor sections to drop down, causing severe injury.</p> <p>TIGHTEN ALL SCREWS (P) AFTER ADJUSTMENT.</p>

- Tighten socket screws (Figure 12, item P) to 100 in-lb (11 N-m)
- Repeat steps 3 to 6 on other foot brackets.
- Position the conveyor mounting bracket and crossmember tube assembly (Figure 14, item H) so there is access to the underside t-slots (P) and hex nuts (M).

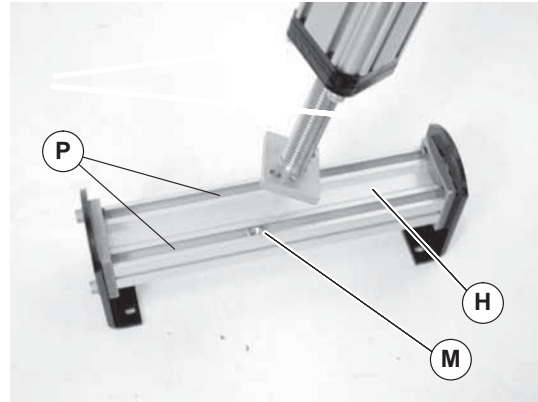

Figure 14

- Align the screw holes (Figure 15, item R) of the stand top screw end plate (Q) with the hex nuts in the t-slots in the crossmember tube (H).

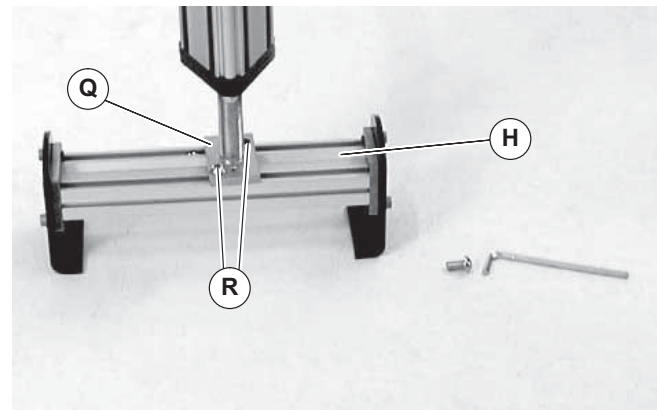



Figure 15

- Attach the button screws to the hex nuts, do not tighten. Position the stand assembly up right.
- To center the conveyor mounting bracket (Figure 14, item H), position the “Attach Here” sticker (Figure 16, item T) with the end plate (S) of the stand top screw assembly.



Figure 16

Preventive Maintenance and Adjustment

⚠ WARNING

<p>Failure to secure screws (Figure 16, item U) may cause conveyor sections to drop down, causing severe injury.</p> <p>TIGHTEN ALL SCREWS (U) AFTER ADJUSTMENT.</p>

- Tighten the button screws (Figure 16, item U) to 100 in-lb (11 N-m).

Preventive Maintenance and Adjustment

Required Tools

- 6 mm Hex Key Wrench
- 5 mm Hex Key Wrench
- 13 mm Open End Wrench

Conveyor Height Adjustment

⚠ WARNING

<p>Exposed moving parts can cause severe injury.</p> <p>LOCK OUT POWER before removing guards or performing maintenance.</p>

⚠ WARNING

<p>Loosening stand height or angle adjustment screws may cause conveyor sections to drop down, causing severe injury.</p> <p>SUPPORT CONVEYOR SECTIONS PRIOR TO LOOSENING STAND HEIGHT OR ANGLE ADJUSTMENT SCREWS.</p>

- Place temporary support stand (Figure 17, item AC) under conveyor (AD).

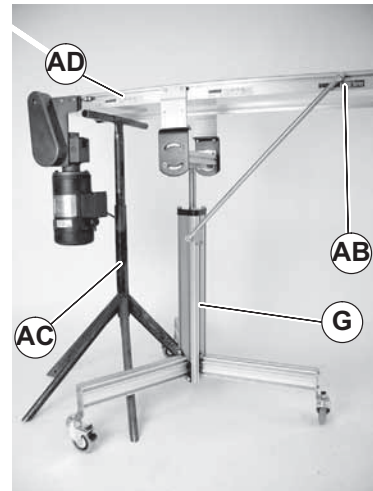

Figure 17

- If installed, remove diagonal brace hardware (Figure 17, item AB) from the conveyor. Allow brace to rest against the trileg post (G).
- Remove conveyor bracket hardware (Figure 18, item AE) from both conveyor supports (AF).



Figure 18

Preventive Maintenance and Adjustment

4. Raise the conveyor (Figure 19, item AG) from the conveyor mounting bracket (H) by adjusting the temporary stand (AC) upward.

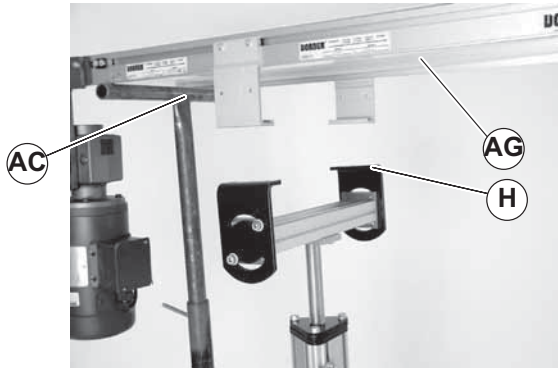

Figure 19

5. Loosen the three tri-lobe hex head screws (Figure 20, item AH).

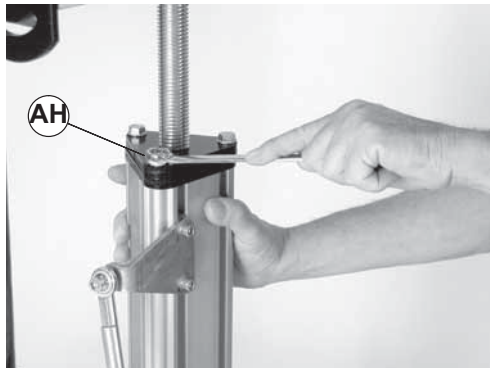

Figure 20

6. Rotate the conveyor mounting bracket and crossmember tube (H) to the proper height.

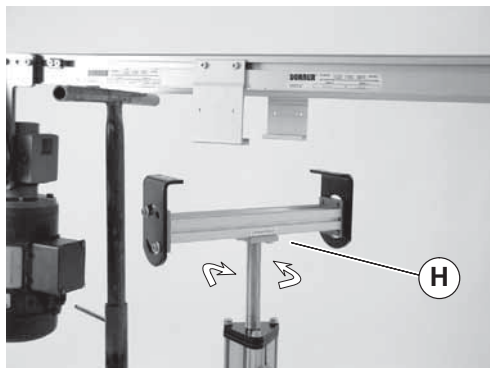

Figure 21

⚠ WARNING
<p>Failure to secure screws (Figure 20, item AH) may cause conveyor sections to drop down, causing severe injury.</p> <p>TIGHTEN ALL SCREWS (AH) AFTER ADJUSTMENT.</p>

7. Re-tighten tri-lobe hex head screws (Figure 20, item AH) to 100 in-lb (11 N-m).
8. Lower conveyor supports (Figure 22, item AF) onto mounting bracket (H). Attach conveyor supports to bracket with hardware (AE).

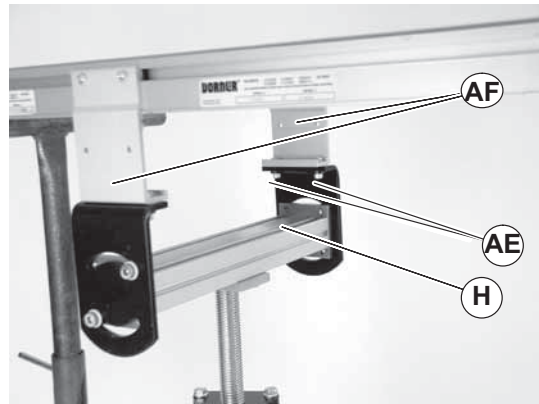



Figure 22

⚠ WARNING
<p>Failure to secure screws (Figure 22, item AE) may cause conveyor sections to drop down, causing severe injury.</p> <p>TIGHTEN ALL SCREWS (AE) AFTER ADJUSTMENT.</p>

9. Tighten fastening hardware (Figure 22, item AE) to 100 in-lb (11 N-m).

Preventive Maintenance and Adjustment

⚠ WARNING

<p>Failure to secure screw (Figure 23, item AB) may cause conveyor sections to drop down, causing severe injury.</p> <p>TIGHTEN ALL SCREWS (AB) AFTER ADJUSTMENT.</p>

10. If installed, reattach brace (Figure 23, item E) and tighten brace fastening hardware (AB) to 100 in-lb (11 N-m).

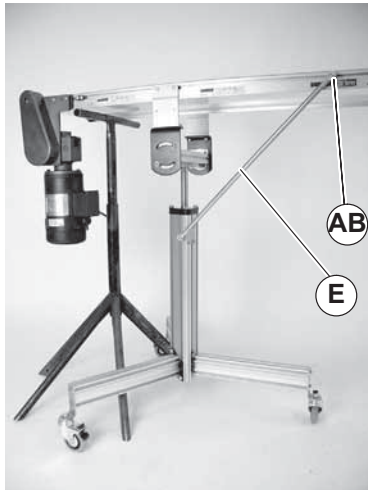



Figure 23

Conveyor Angle Adjustment

⚠ WARNING

<p>Loosening stand height or angle adjustment screws may cause conveyor sections to drop down, causing severe injury.</p> <p>SUPPORT CONVEYOR SECTIONS PRIOR TO LOOSENING STAND HEIGHT OR ANGLE ADJUSTMENT SCREWS.</p>

NOTE
<p>To rotate stand, screws (Figure 24, item AL) may need to be re-located to other holes in the stand top end plate (AK).</p>

1. Loosen flange socket screws (Figure 24, item AL) on both sides of stand.

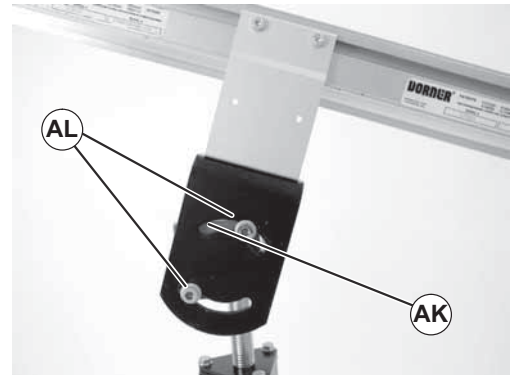

Figure 24

2. If conveyor is equipped with diagonal bracing (Figure 25, item E), socket screw (AB) must be loosened to adjust conveyor angle.

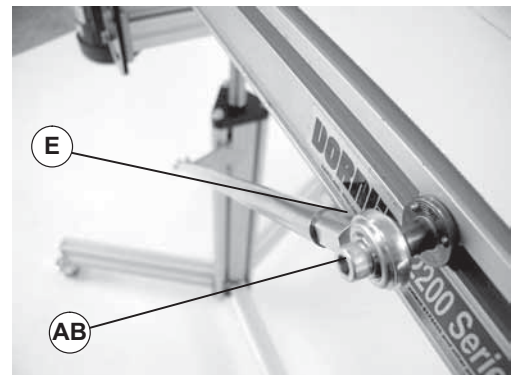



Figure 25

3. Adjust conveyor to desired angle.

⚠ WARNING

<p>Failure to secure screws (Figure 26, item AL) may cause conveyor sections to drop down, causing severe injury.</p> <p>TIGHTEN SCREWS (AL) AFTER ADJUSTMENT.</p>

4. Secure flange socket screws (Figure 26, item AL) on both sides of stand to 100 in-lb (11 N-m).

Preventive Maintenance and Adjustment



Figure 26

⚠ WARNING	
	
Failure to secure screw (Figure 24, item AB) may cause conveyor sections to drop down, causing severe injury.	
TIGHTEN SCREW (AB) AFTER ADJUSTMENT.	

5. If installed, reattach diagonal bracing (Figure 27, item E) and tighten brace fastening hardware (AB) to 100 in-lb (11 N-m).

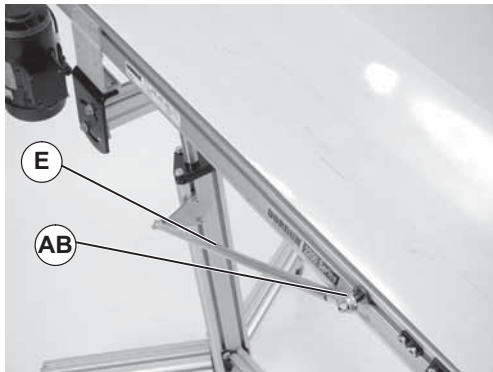

Figure 27

Service Parts

NOTE

For replacement parts other than those shown on this page, contact an authorized Dorner Service Center or the factory.

Single Post/Pillar Support Stands

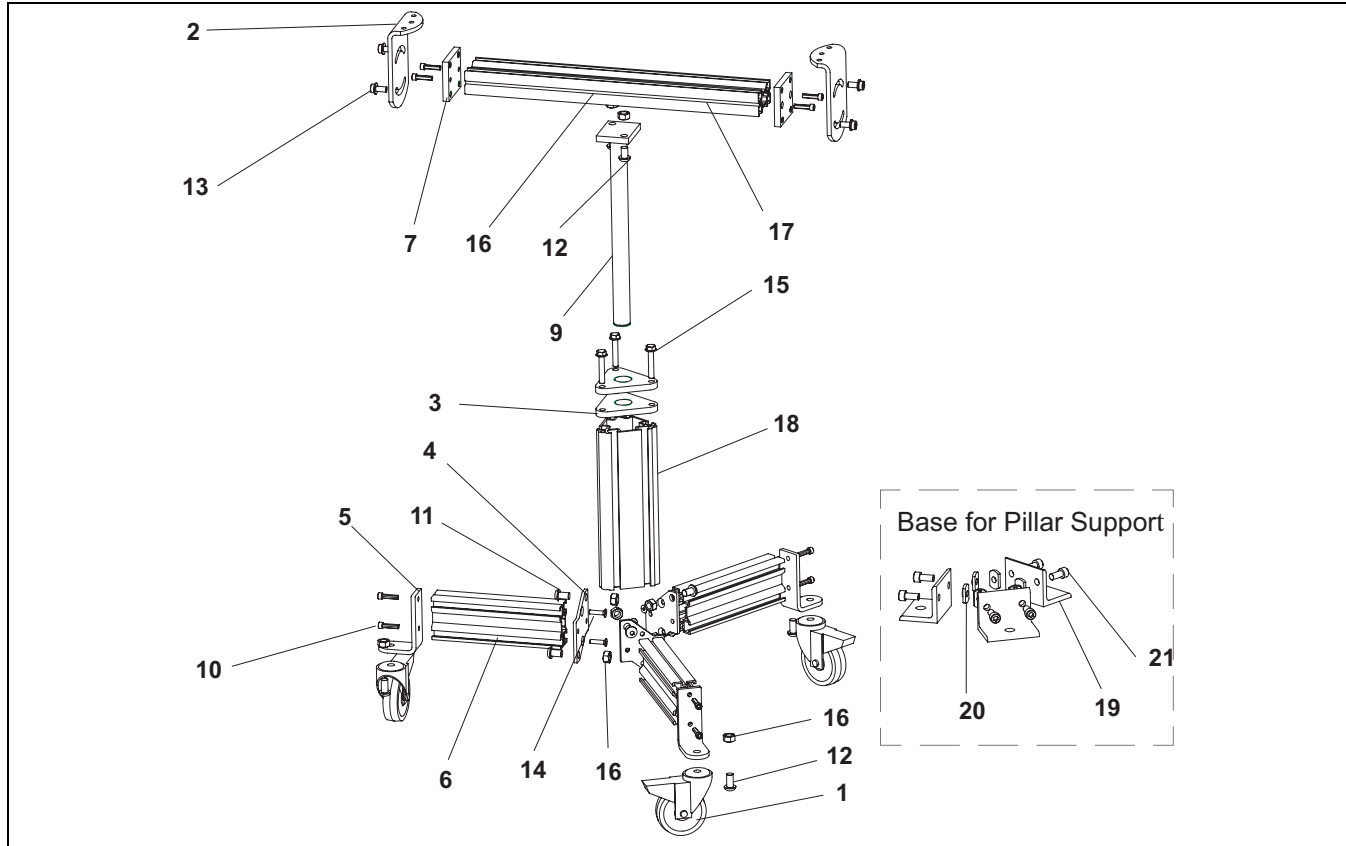

Figure 28

Item	Part Number	Description
1	807-936	Caster, 4"
2	200697	Brkt, Pivot, Mtg-Stand
3	688038	Plate, Clamp, Screw
4	710048	Plate, End, Crossmember Stand
5	710049	Angle, Foot, Sgl Post Stand
6	See Leg Tube Table	Leg, Stand, Extrusion
7	710222	Plate, End, Tube Stand Top
9	710231	Screw, Assy, Top, Stand
10	708180P	Scr, Sock, Metric M6-1.00x25mm
11	911016M	Scr, Bttn, Metric M10-1.50x16mm
12	911020M	Scr, Bttn, Metric M10-1.50x20mm
13	920883M	Scr, Flange, Socket M8-1.25x16mm
14	930625M	Scr, Flat, Metric M6-1.00x25mm
15	90898M	Scr, Tri-Lobe, Hd Hex M8x45mm
16	991001M	Nut, Hex, Full M8-1.25
17	See Cross-Member Tube Table	Tube, Crossmember

Item	Part Number	Description
18	See Trileg Post or Pillar Column Tube Table	Post, Trileg
19	241650	Stand Foot Bracket
20	807-1075	Nut, Weld M8x1.25-6H
21	920816M	Scr, Sock, Metric M8-1.25x16mm

Item 6: Leg Tube Table	
Stand Height Range	Leg
16"–26" (406mm–660mm)	710214–00800
24"–34" (609mm–864mm)	710214–00950
32"–42" (813mm–1067mm)	710214–01100
40"–50" (1016mm–1270mm)	710214–01250
48"–58" (1219mm–1473mm)	710214–01400

Item 17: Crossmember Tube Table	
Stand Width	Crossmember
2" (51mm)	710209–00200
3" (76mm)	710209–00300
4" (102mm)	710209–00400
5" (127mm)	710209–00525
6" (152mm)	710209–00625
8" (203mm)	710209–00825
10" (254mm)	710209–01025
12" (305mm)	710209–01225
14" (356mm)	710209–01425
16" (406mm)	710209–01625
18" (457mm)	710209–01825

Item 18: Trileg Post Table for Single Post Support Stands		
Stand Height Range	Trileg Post With Feet Column Tube	Trileg Post With Casters Column Tube
16"–26" (406mm–660mm)	687657P–01000	687657P–00600
24"–34" (609mm–864mm)	687657P–01800	687657P–01400
32"–42" (813mm–1067mm)	687657P–02600	687657P–02200
40"–50" (1016mm–1270mm)	687657P–03400	687657P–03000
48"–58" (1219mm–1473mm)	687657P–04200	687657P–03800

Item 18: Trileg Pillar Table for Pillar Support Stands		
Stand Height Range	Trileg Pillar Column Tube	
16"–26" (406mm–660mm)	687657P–01050	
24"–34" (609mm–864mm)	687657P–01850	
32"–42" (813mm–1067mm)	687657P–02650	
40"–50" (1016mm–1270mm)	687657P–03450	
48"–58" (1219mm–1473mm)	687657P–04250	

Return Policy

Returns must have prior written factory authorization or they will not be accepted. Items that are returned to Dorner without authorization will not be credited nor returned to the original sender. When calling for authorization, please have the following information ready for the Dorner factory representative or your local distributor:

1. Name and address of customer.
2. Dorner part number(s) of item(s) being returned.
3. Reason for return.
4. Customer's original order number used when ordering the item(s).
5. Dorner or distributor invoice number.

A representative will discuss action to be taken on the returned items and provide a Returned Goods Authorization number for reference.

There will be a return charge on all new undamaged items returned for credit where Dorner was not at fault. Dorner is not responsible for return freight on such items.

Conveyors and conveyor accessories	
Standard catalog conveyors	30%
MPB Series, cleated and specialty belt conveyors	50%
7400 & 7600 Series conveyors	non-returnable items
Engineered special products	case by case
Drives and accessories	30%
Sanitary stand supports	non-returnable items

Parts	
Standard stock parts	30%
MPB, cleated and specialty belts	non-returnable items

Returns will not be accepted after 60 days from original invoice date.

The return charge covers inspection, cleaning, disassembly, disposal and reissuing of components to inventory.

If a replacement is needed prior to evaluation of returned item, a purchase order must be issued. Credit (if any) is issued only after return and evaluation is complete.

Dorner has representatives throughout the world. Contact Dorner for the name of your local representative. Our Technical Sales, Catalog Sales and Service Teams will gladly help with your questions on Dorner products.

For a copy of Dorner's Warranty, contact factory, distributor, service center or visit our website at www.dorner.com.

For replacement parts, contact an authorized Dorner Service Center or the factory.



Dorner Mfg. Corp. reserves the right to change or discontinue products without notice. All products and services are covered in accordance with our standard warranty. All rights reserved. © Dorner Mfg. Corp. 2006

DORNER MFG. CORP.

975 Cottonwood Ave., PO Box 20
Hartland, WI 53029-0020 USA
USA
TEL 1-800-397-8664 (USA)
FAX 1-800-369-2440 (USA)
Internet: www.dorner.com

Outside the USA:
TEL 1-262-367-7600
FAX 1-262-367-5827