

Fast & Simple to Use
Online Configurator

Patent Pending Pinch
Drive Design

Clean Room Certified
Class 100

Industry-Best
Product Transfers



1100 SERIES CONVEYORS

The Industry's Smallest Conveyor
Designed to Fit in the Tightest Spaces!

DORNER[®] 

1100 SERIES

1100 Series Conveyors are best for:

- Small or Light Weight Product Handling
- Small Part Transfers
- Tray Handling
- Pill Package Handling
- Package Labeling
- Pharmaceutical Applications
- Life Science Applications
- Medical Applications

Sizes & Measurements

- Widths: 44mm (1.75 in), 95mm (3.75 in), 152mm (6 in), 203mm (8 in), & 254mm (10 in)
- Lengths: 270mm (10.63 in) to 1,829mm (72 in) in 3mm (.125 in) increments

Belt Types

- 3 FDA Approved Belt Options:
- Low Friction
 - Medium Friction
 - High Friction

Loads & Speeds

- Loads up to 6.8 kg (15 lbs)
- Speeds up to 21 m/min (80 ft/min)

Guiding

- UHMW Guides
- 25mm (1 in)
- 51mm (2 in)



Drives

Flat Belt End Drives



Side Mount

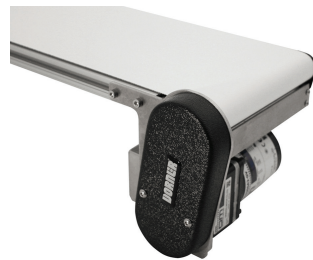

Bottom Mount

Flat Belt Mid Drives



Type 1 Mount



Type 2 Mount



Small Part Transfers

- Flush Frame allows for side transfers
- Optional 8 mm (.3125 in) nose bar on one or both ends



Miniature Frame Design

- 19 mm (.75 in) frame height
- 16 mm (.625 in) or 8 mm (.3125 in) diameter idler pulleys
- Optimal size for handling and transferring of small parts
- T-Slot for fast mounting of accessories
- Flush edge design to fit into tight spaces
- Cam belt tracking conveyor extends only 3/4" beyond frame

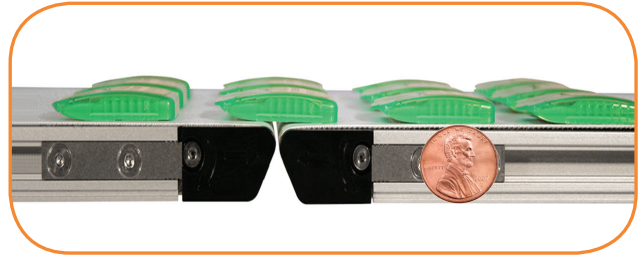

Pinch Drive Design (Patent Pending)

- Low belt tension virtually eliminates belt stretch providing maintenance free operation
- Belt is tracked continuously with unique frame design, cams, and pinch drive for consistent performance
- Drive is reversible, providing maximum flexibility in applications
- Two half design with one fastener per side allows cover to pivot for fast belt change
- T-Slot for flexible mounting
- Spring tensions belt around drive pulley for 180° of wrap
- 32 mm (1.25 in) lagged urethane drive spindle

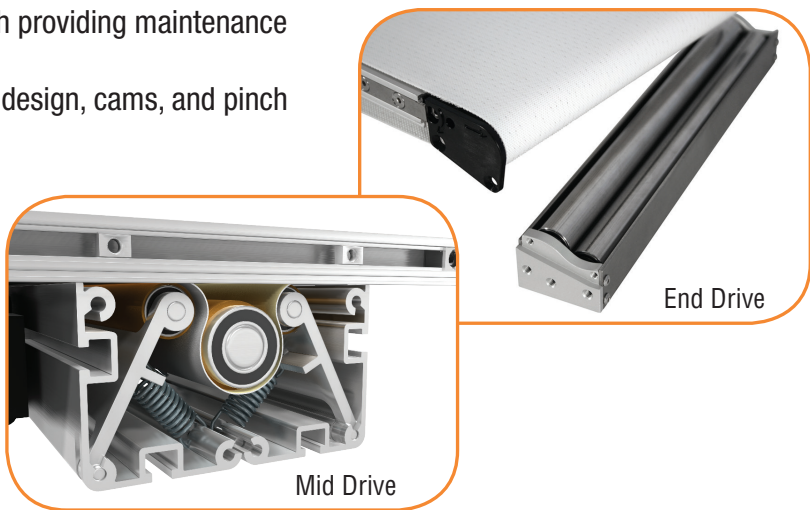

Backlit Capability

- Backlit conveyor with an LED light is ideal for inspection and quality control
- Provides a contrast between the product and conveyor belt for both visual inspection and vision system interface
- Parts can be stopped directly over the lighted section or continue through uninterrupted
- Unique design allows access to LED panel without removal of the belt for ease of use and light color changes

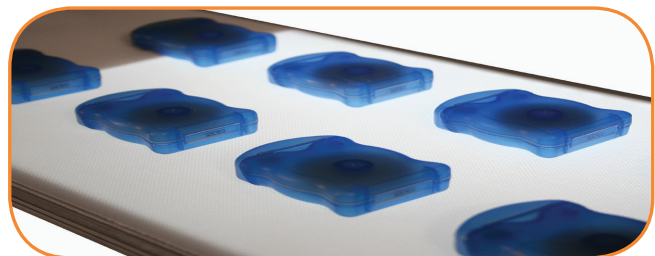

The Benefits of a Dorner 1100 Series Conveyor

Industry Ready

- Clean Room Class 100 Certified for medical and pharmaceutical applications
- T-Slot for ease and flexibility in mounting automation components or accessories
- FDA Approved Belting

Time Saving

- Dorner's online configuration engineers simple or complex conveyors to meet your needs in minutes
- The industry leading tool delivers a complete 3D CAD Assembly model for instant validation of fit
- Dorner provides the industry's fastest deliveries

Industrial & Automation Conveyors

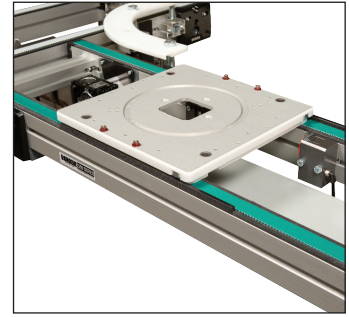
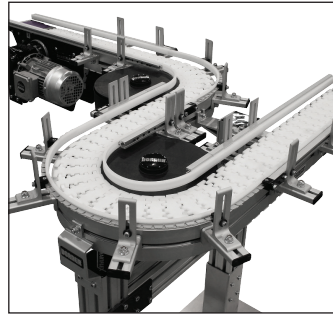
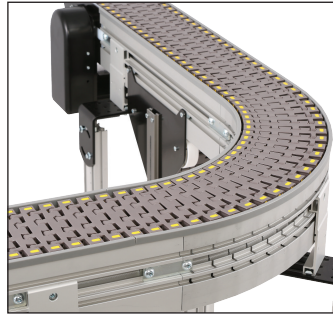

Sanitary Conveyors

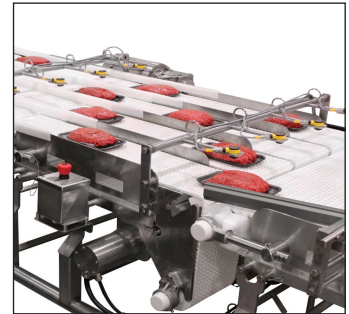
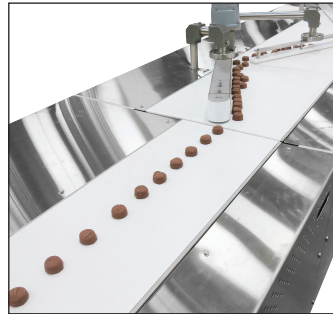
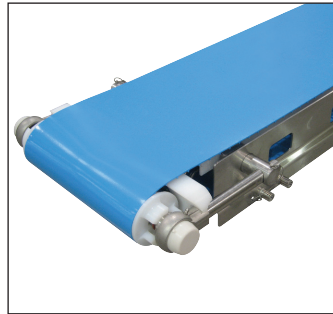
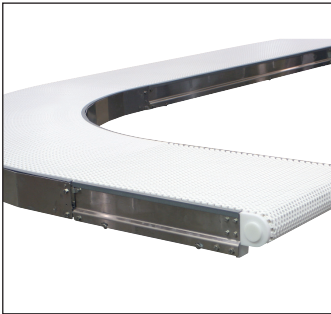

Engineered Solutions



Parts

Service

Online Configurator

Warranty

Transforming Conveyor Automation

Dorner – North & South America

Dorner – U.S.A. Headquarters
975 Cottonwood Ave
Hartland, WI 53029, USA
(800) 397-8664
(262) 367-7600
info@dorner.com

Dorner – Canada
100-5515 North Service Road
Burlington, Ontario L7L 6G6
Canada
(289) 208-7306
info@dorner.com

Dorner – Latin America
Carretera a Nogales #5297,
Nave 11. Parque Industrial Nogales
Zapopan, Jalisco C.P. 45222
Mexico
+52.33.30037400
info.latinamerica@dorner.com



Dorner – Europe

Dorner – Germany
Karl-Heinz-Beckurts-Straße 7
52428 Jülich, Germany
+49 (0) 2461/93767-0
info.europe@dorner.com

Dorner – France
8-10 Rue de Nieuport
78140 Vélizy-Villacoublay,
France
+33 (0)1 84 73 24 27
info.france@dorner.com

Dorner – Asia

128 Jalan Permatang Damar Laut, Bayan Lepas 11960
Penang, Malaysia
+604-626-2948 | info.asia@dorner.com

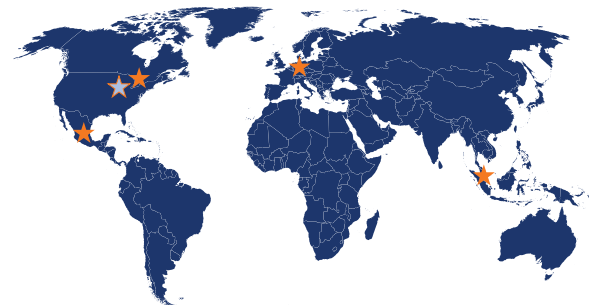

www.dornerconveyors.com