

## Operating & Installation Manual



**Variable Speed Controller for  
DC Motors Up To 1/2 hp  
115 VAC, 50/60 Hz, Single-Phase Input**

**Models: 711-2111 & 711-2112**

# Table of Contents

1.0	Safety Considerations .....	3
1.1	Grounding .....	3
1.2	Fusing .....	3
1.3	Power Wiring to Conveyor Controller .....	3
2.0	Introduction .....	3
3.0	Product Description .....	3
4.0	Product Specifications .....	4
5.0	Conveyor Controller Installation .....	5
5.1	Inspecting the Controller .....	5
5.2	Mounting the Controller .....	5
5.3	Power Connections to Conveyor Controller .....	6
5.4	Conveyor Controller Power-up Test .....	6
5.5	Motor Connections to Conveyor Controller .....	6
5.6	Motor and Conveyor Controller Power-up Test .....	6
5.7	Internal Adjustments .....	7
	1. General .....	7
	2. Minimum Speed (MIN) .....	7
	3. Maximum Speed (MAX) .....	7
	4. Torque (TORQ) .....	8
	5. Acceleration/Deceleration Time (ACC) .....	8
	6. Speed Regulation (REG) .....	8
5.8	Controller Setup .....	9
	1. Reversing .....	9
	2. Dynamic Braking .....	9
5.9	Controlling the Speed with an External Reference Signal .....	10
6.0	Implementing Conveyor Control Applications .....	10
7.0	Operating the Conveyor Controller .....	12
7.1	Starting the Controller .....	12
7.2	Stopping the Controller .....	12
8.0	Troubleshooting .....	12
9.0	Replacement Parts List .....	16
	Standard Available IMPAC Accessory Kits .....	17
	Return Policy .....	18



# impac 100 Operating & Installation Manual

## Variable Speed DC Motors, Single-Phase

### 1.0 Safety Considerations

	<b>WARNING</b>	
<b>Disconnect power at source before opening door of <i>impac</i> 100 Conveyor Controller.</b>		

#### — 1.1 Grounding

	<b>WARNING</b>	
<b>Both control enclosure and motor must be securely mounted and properly grounded. Failure to properly ground either device may cause injury to personnel.</b>		



#### — 1.2 Fusing

	<b>WARNING</b>	
<b>If fuses need to be replaced, they must always conform to the values and ratings specified on the controls labels.</b>		

#### — 1.3 Power Wiring to Conveyor Controller

	<b>WARNING</b>	
<b>The branch circuit, which provides power to this control, must be protected. The circuit protection must be properly sized to meet the current requirements and must comply with all applicable codes.</b>		

### 2.0 Introduction

	<b>WARNING</b>	
<b>Read this Manual completely and carefully. Pay special attention to the Warnings, Precautions, and Safety Rules listed. Failure to follow the instructions could produce Safety Hazards to personnel or lead to damage of the Conveyor Controller and/or the optional Accessory Kits. Due to the wide variety of setups &amp; applications, guarding is the responsibility of the end user.</b>		

This manual contains the information needed to install, operate, and troubleshoot the Dorner *impac* 100 Conveyor Controller. It is organized in a step-by-step fashion so that the Conveyor Controller may be safely set-up, in the shortest possible time.

### 3.0 Product Description

The *impac* 100 Conveyor Controller is a low-cost Industrial Multi-Purpose Application Controller that can be used to control a Conveyor motor on/off operation as well as vary the speed of the motor. The Conveyor Controller is user-installable with control options that allow it to meet the needs of a wide range of Conveyor control applications (indexing, jogging, accumulation, variable speed, automatic end-stop, emergency-stop, clutch-brake, merging of Conveyors, linking multiple Conveyors, ...etc.). The Conveyor Controller can be ordered for Conveyors with fixed or variable speed AC or DC motors.

The *impac* 100 Conveyor Controller's motor control circuit is designed to support electrical interconnections to a variety of accessory kits (photo-eyes, E-stops, jog buttons, foot switches, E-stop pull cord units, process machine/PLC/PC dry contact interface, and more). Each kit includes brackets for mounting the unit to a Dorner 2100/3100 conveyor, cabling to wire the unit to an *impac* 100 Conveyor Controller, and instructions for mounting/wiring/operating the unit. The kits are connected to the *impac* 100 Conveyor Controller using convenient terminal point connections, inside the Controller. This allows the user to configure the kits to fit specific application needs and to re-configure the kits to perform new functions.

The *impac* 100 Conveyor Controller comes with mounting hardware to allow mounting to a Dorner 2100 or 3100 Conveyor side rail (or Conveyor stand). The unit is housed in a NEMA 12/IP54 enclosure with Power "ON" and Motor "RUNNING" LED's, a locking "ON/OFF" switch, a 24 volts D.C. power supply, adjustable motor overloads with manual reset, and pre-wired motor and AC line cords. The Conveyor Controller supports both fixed and variable speed AC motors using 120/230/460 volts A.C., 50/60Hz, 1-3 Phase, and variable speed 90 or 130 volt D.C. motors with 120 volt A.C. input.

Overall Conveyor system reliability is enhanced by the *impac* 100 design features. Components meet applicable ANSI/NEC/IEC machine safety standards. Local on/off control and built-in motor & circuit overload protection enhance operator and application safety. Low voltage (24 volts D.C.) control circuits reduce installation and maintenance time as well as increase safety. A complete Conveyor Controller wiring schematic and troubleshooting guide are attached to the inside of the Conveyor Controller cover.

# *impac* 100 Operating & Installation Manual

## Variable Speed DC Motors, Single-Phase

### 4.0 Product Specifications

<i>impac</i> 100	711-2111	711-2112
<b>Input Voltage</b>	115 volts A.C. $\pm$ 10% 50/60 Hz	
<b>Input Line Fuse</b>	(1) 10 Ampere	(1) 15 Ampere
<b>Input Current</b>	5 Amperes	9 Amperes
<b>Output Voltage</b>	130 volts D.C.	
<b>Trim Potentiometer Adjustments</b>	Minimum Speed (0 to 30 %), Maximum Speed (40 to 100 %), Torque Limit (to 200 %) Adjustable Acceleration/Deceleration, Adjustable IR Compensation for Improved Speed Regulation	
<b>Motor Fuse</b>	4 Amperes	7 Amperes
<b>Motor Range</b>	Below 1/3 HP 1 to 246 Watts	1/3 to 1/2 HP 246 to 373 Watts
<b>Operating Temperature</b>	0 to 40° C to 95% Humidity (Non-condensing)	
<b>A.C. Line Cord</b>	8 Ft (2.4 m) Pre-Wired with molded NEMA 5-15P Plug	
<b>Motor Cord</b>	5 Ft (1.5 m) Pre-Wired with molded NEMA 5-15R Receptacle	
<b>Enclosure</b>	NEMA Type 12 / IP54 Continuous Hinge, Weight: 23 lb (10.5 kg) Dimensions: 12" (305 mm) High x 10" (254 mm) Wide x 5" (127 mm) Deep	
<b>Internal Power Supply</b>	24 volts D.C. 1.1 Ampere Over-current and Short-circuit Protected	
<b>Standard Features</b>	<ul style="list-style-type: none"> <li>● Lockable Disconnect Switch</li> <li>● Line Fuses(s)</li> <li>● Angled Terminal Block for Easy Field Connections</li> <li>● 24 volt D.C. Power Supply Rated @ 1.1 Amperes for Field Devices</li> <li>● POWER "ON" and MOTOR RUNNING Indicator Lights</li> <li>● Mounting Brackets and Hardware</li> <li>● Pre-wired Motor and AC Line Cords</li> <li>● Schematic Diagram Inside of Door</li> <li>● Four (4) 1/2" NPT Knockouts at Bottom of Enclosure with NEMA 12 Plugs</li> <li>● Motor Dynamic Braking</li> <li>● Speed Potentiometer Mounted on Enclosure Door</li> <li>● Reversing Switch Mounted on Enclosure Door</li> </ul>	

#### NOTE:

For additional information, refer to the following Dorner Publications:

- *impac* 100 Catalog (Dorner Publication # 851-151)
- *impac* 100 Accessory Kits Setup & Installation Guides (Dorner Publication # 851-108 through # 851-121)
- *impac* 100 Application Guide (Dorner Publication # 851-124)

# impac 100 Operating & Installation Manual

## Variable Speed DC Motors, Single-Phase

### 5.0 Conveyor Controller Installation

#### 5.1 Inspecting the Controller

Carefully examine your Controller (and any option kits, if ordered), for shipping damage. Check to be certain that the controller you ordered is the one you received. Also check any optional accessory kits which you received.

#### 5.2 Mounting the Controller

Select the desired location and mount the *impac* 100 enclosure to the conveyor T-slot channel (Figure 2) or an aluminum support stand leg (Figure 3) or steel support stand leg (Figure 4), using the hardware provided.

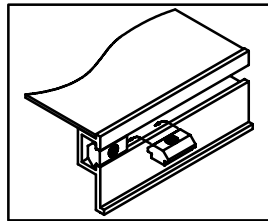

**Figure 1: Drop-in T-bar Installation Detail**

#### Mounting in Conveyor T-slot

- Insert the two Single Drop-in T-bars into conveyor T-slot by rolling each one into position (Figure 1).
- Select the desired location and attach the *impac* 100 enclosure (in the same way it was packaged, when shipped) to the conveyor T-slot in the manner shown in Figure 2 using the two (2) M6 x 8 mm Button Head Cap Screws through the clearance hole in each Mounting Bar. Tighten the Screws with a 4 mm Hex Key Wrench.

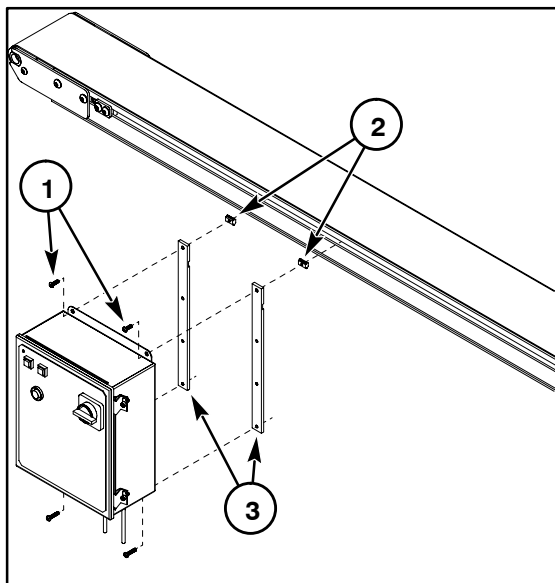

- 1- M6 x 8 mm Button Head Cap Screws (2 each)
- 2- Single Drop-in T-bars (2 each)
- 3- Mounting Bars (2 each)

**Figure 2: Conveyor T-slot Attachment Detail**

#### Mounting to Aluminum Support Stand Leg

- For an Aluminum Support Stand Leg, refer to Figure 3 and detach, rotate and re-attach the Mounting Bars to the *impac* 100 enclosure in the horizontal position.
- Select the desired mounting location and insert the two Single Drop-in T-bars into Leg channel by rolling each of them into position (see Figure 1).
- Then, attach the *impac* 100 enclosure to the two Single Drop-in T-bars, using the M6 x 8 mm Button Head Cap Screws. Tighten Screws with a 4 mm Hex Key Wrench.

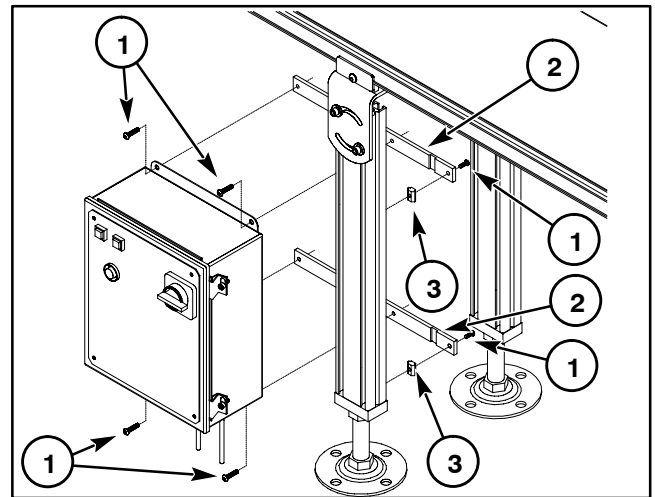

- 1- M6 x 8 mm Button Head Cap Screws (6 each)
- 2- Mounting Bars (2 each)
- 3- Single Drop-in T-bars (2 each)

**Figure 3: Aluminum Leg Attachment Detail**

#### Mounting to Steel Support Stand Leg

- For the Steel Support Stand Leg, refer to Figure 4 and detach, rotate and re-attach the Mounting Bars to the *impac* 100 enclosure in the horizontal position.
- Then, attach the *impac* 100 enclosure to the M6 Spring Nuts, using the M6 x 18 mm Button Head Cap Screws through the clearance hole in each Mounting Bar. Tighten the Screws with a 4 mm Hex Key Wrench.

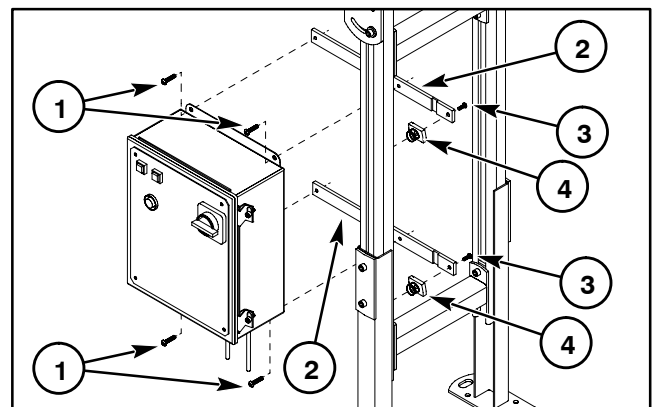

- 1- M6 x 8 mm Button Head Cap Screws (4 each)
- 2- Mounting Bars (2 each)
- 3- M6 x 18 mm Button Head Cap Screws (2 each)
- 4- M6 Spring Nuts (2 each)

**Figure 4: Steel Leg Attachment Detail**

# impac 100 Operating & Installation Manual

## Variable Speed DC Motors, Single-Phase

### 5.3 Power Connections to Conveyor Controller

The conveyor controller is provided with a pre-wired plug (A of Figure 5) for power.

**WARNING**

Disconnect power, at power source, before opening the door of the *impac* 100 Conveyor Controller and attempting to make any electrical connections. Connections to the power source should always be the very last connections made.

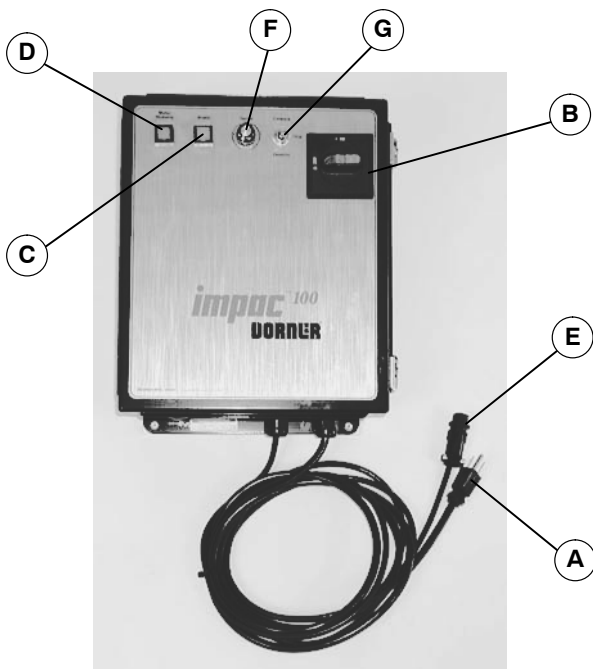

Figure 5: Conveyor Controller

### 5.4 Conveyor Controller Power-up Test

Test the conveyor controller before the motor is connected and before any *impac* accessory kits are installed. Plug the controller power plug (A of Figure 5) into an appropriate power source. Turn the controller disconnect switch (B) to ON. The POWER and MOTOR RUNNING indicator lights (C) and (D) should illuminate.

### 5.5 Motor Connections to Conveyor Controller

**WARNING**

Remove power, from the *impac* 100 Conveyor Controller, by unplugging it from the power source, before opening the door and attempting to make or disconnect any electrical connections.

#### NOTE:

Each conveyor controller is provided with a pre-wired motor receptacle (E of Figure 5). The type of receptacle is dependent on the controller voltage. If a motor was ordered with the controller, the motor is pre-wired with a mating power plug. The motor can also be hard-wired to the controller. First remove the receptacle and then connect the wires directly to the terminals “T1”, “T2”, and “GND”, inside the controller. See the conveyor controller panel layout (Figure 6) and the schematic diagram (Figure 7) for more information.

Plug the motor cord plug (not shown) into the *impac* 100 conveyor controller motor receptacle (E).

### 5.6 Motor and Conveyor Controller Power-up Test

**WARNING**

When power is supplied to the *impac* 100 Conveyor Controller and the disconnect switch is turned “ON”, the Conveyor belt will begin to move.

After connections are made to the *impac* controller, move the main speed potentiometer (F of Figure 5) to zero and the FORWARD-STOP-REVERSE switch (G) to the “STOP” position. Plug the controller into the appropriate power source and turn the controller disconnect switch (B) ON. The POWER indicator light (C) should illuminate. Move the FORWARD-STOP-REVERSE switch (G) to “FORWARD”. The MOTOR RUNNING indicator light (D) should illuminate. Slowly advance the main speed potentiometer (F) until you reach the desired speed. The motor should run and the conveyor belt will move. If the motor runs in the opposite direction, the armature leads will have to be reversed.

#### NOTE:

If the conveyor being controlled is a DORNER Horizontal Center Drive, then the DC *impac* 100 is shipped with the reversing switch disabled.

# impac 100 Operating & Installation Manual

## Variable Speed DC Motors, Single-Phase

! WARNING !

Remove power, from the *impac* 100 Conveyor Controller, by unplugging it from the power source, before opening the door and attempting to make or disconnect any electrical connections.

Once the power has been removed, open the *impac* Conveyor Controller door and reverse the armature leads at the terminals, at the bottom of the controller, labelled “T1” and “T2”.

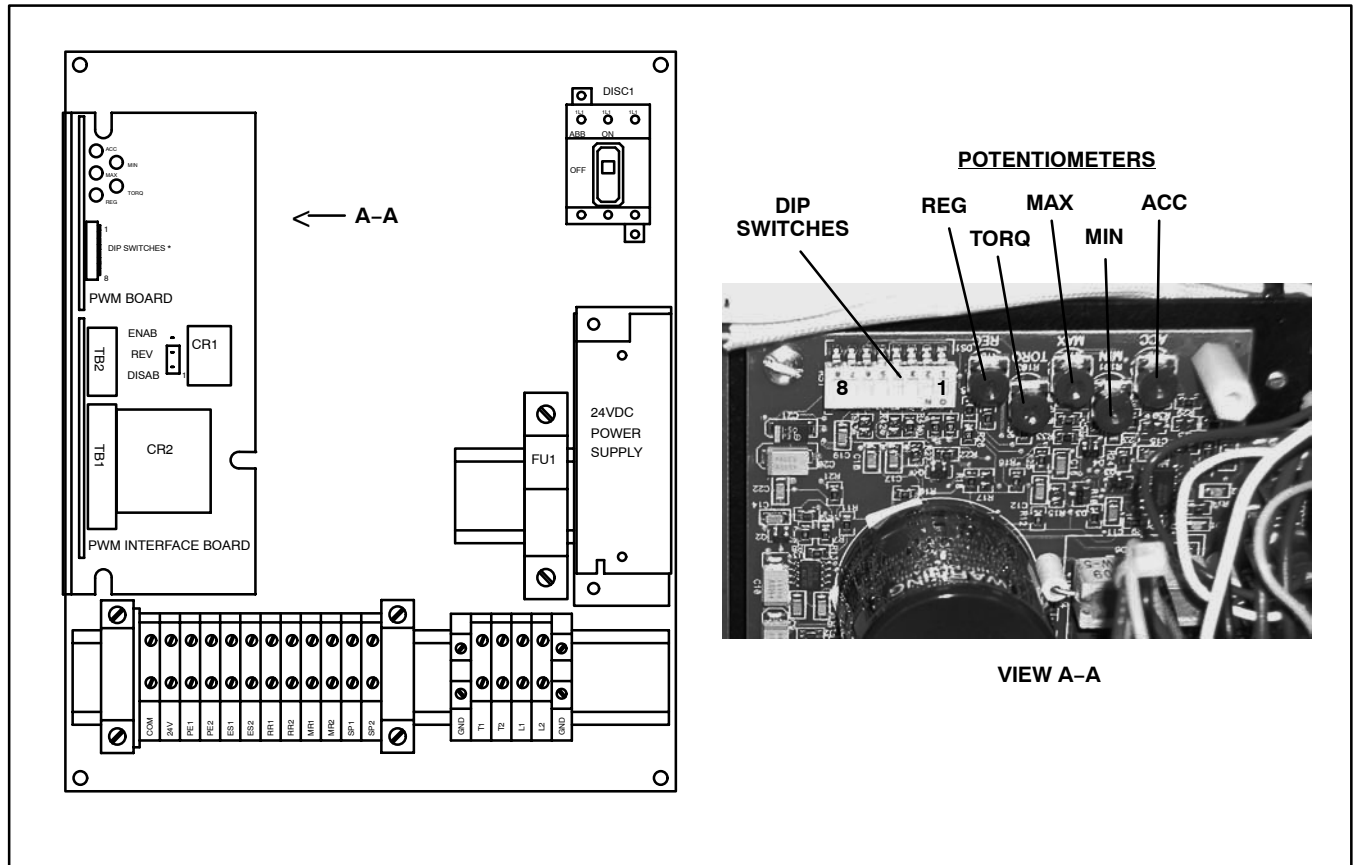

Figure 6: Conveyor Control Panel Layout

### 5.7 Internal Adjustments

! WARNING !

The *impac* 100 Conveyor Controller operates at voltages capable of causing serious injury or death. If adjustments are made while under power, insulated adjusting tools must be used and eye protection must be worn.

#### 1. General

The printed circuit board has five factory preset adjustments: Minimum Speed, Maximum Speed, Torque, Acceleration/Deceleration Time, and Speed Regulation. The adjustment potentiometers are located

on the PWM circuit board near the main terminal block. See Figure 6.

#### 2. Minimum Speed (MIN)

Minimum motor speed can be changed by adjusting the “MIN” potentiometer. With the main speed potentiometer (F of Figure 5) at the zero setting, turn the “MIN” adjustment potentiometer clockwise, until the desired speed is reached. Full counterclockwise adjustment yields zero speed.

#### 3. Maximum Speed (MAX)

The maximum motor speed can be changed by adjusting the “MAX” speed potentiometer. With the main speed potentiometer (F of Figure 5) set at the highest speed, turn the “MAX” speed potentiometer counterclockwise until the desired maximum speed is reached. Clockwise rotation of the potentiometer increases the motor speed. The range is 60% to 100% of maximum output speed.

# impac 100 Operating & Installation Manual

## Variable Speed DC Motors, Single-Phase

### NOTE:

Do not adjust the motor speed above its base rating. Running the motor above the nameplate speed (voltage) can lead to excess brush wear.

#### 4. Torque (TORQ)

The torque capability of the motor can be changed by adjusting the “TORQ” potentiometer. Turn the “TORQ” potentiometer counterclockwise to lower torque. Full counterclockwise adjustment yields zero torque (stall).

#### 5. Acceleration/Deceleration Time (ACC)

The acceleration and deceleration times of the motor can be changed by adjusting the “ACC” potentiometer. Turn the “ACC” potentiometer clockwise to simultaneously increase acceleration and deceleration times within a range determined by the settings of DIP switches 7 and 8. Refer to the DIP switch table in Figure 8.

#### 6. Speed Regulation (REG)

The controller has been factory preset for optimum performance, over the entire speed range, and should require no further readjustment. If improved speed regulation is desired at a given speed, it may be necessary to readjust the “REG” potentiometer. Turn the “REG” potentiometer clockwise to increase speed regulation (IR compensation).

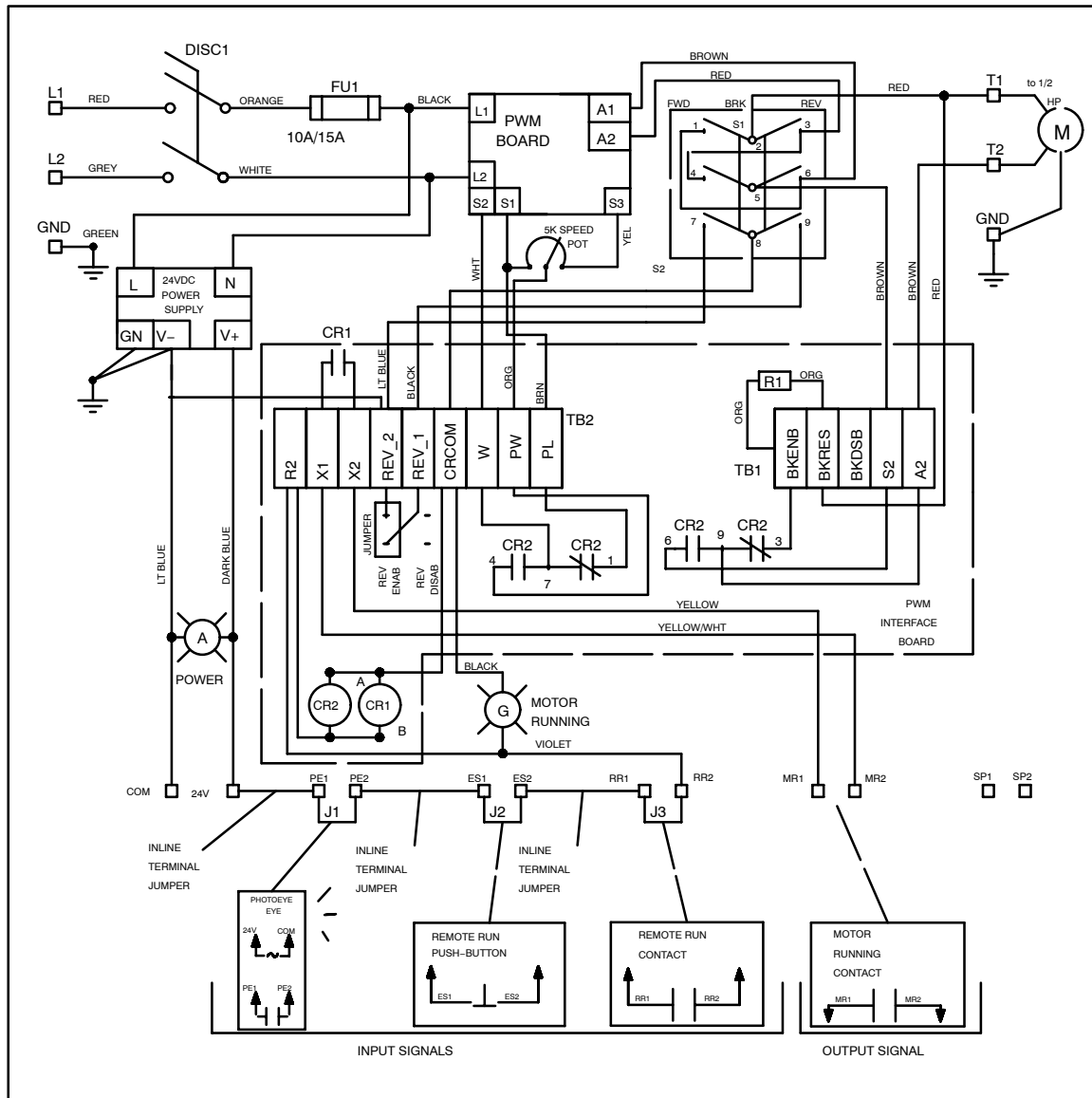

**Figure 7: Schematic Diagram for 115 volts D.C. Controller**



# impac 100 Operating & Installation Manual

## Variable Speed DC Motors, Single-Phase

MOTOR			CONTROL SETUP
MFR	TYPE	AMPS	DIP SWITCHES ON
Bodine	24A4	0.45	NONE
	33A3	0.71	1
	32A3		
	32A4	0.62	1
	33A5	1.00	3
	32A5		
	42A3	1.00	1,3
	42A4	1.20	2,3
	42A5	1.80	3,5
	42A7	2.30	2,3,5
Leeson	098178	2.20	1,2,3,5
	098295 (90 vdc)	5.00	1,2,3,4,5,6

DIP SWITCH		ACCEL/DECEL TIME RANGE (Seconds)	
7	8	ACC Pot Fully CCW	ACC Pot Fully CW
OFF	OFF	0.1	0.3
OFF*	ON*	0.5*	2.0*
ON	OFF	3.5	12.0
ON	ON	4.0	15.0

\* Factory Setting

**Figure 8: DIP Switch Settings**

### 5.8 Controller Setup

! WARNING !

**Remove power, from the *impac* 100 Conveyor Controller, by unplugging it from the power source, before opening the door and attempting to make or disconnect any electrical connections.**

#### 1. Reversing

If the conveyor being controlled is a DORNER Horizontal Center Drive, then the DC *impac* 100 is shipped with the reversing switch disabled. Damage may occur to the conveyor belt if operated in the reverse direction. If a Center Drive is not being used, then the

controller is shipped with the reversing switch enabled. Reversing can be enabled as follows:

- a. Open the cover of the *impac* 100. The REV jumper is located between (CR1) and (TB2) on the PWM Interface Board (see Figure 9). The jumper is set across two adjacent pins labeled “REV and DISAB”.
- b. Remove the jumper and replace it over the pins labeled “REV and ENAB”. Reversing of the motor with the FORWARD-STOP-REVERSE switch on the controller door is now possible.

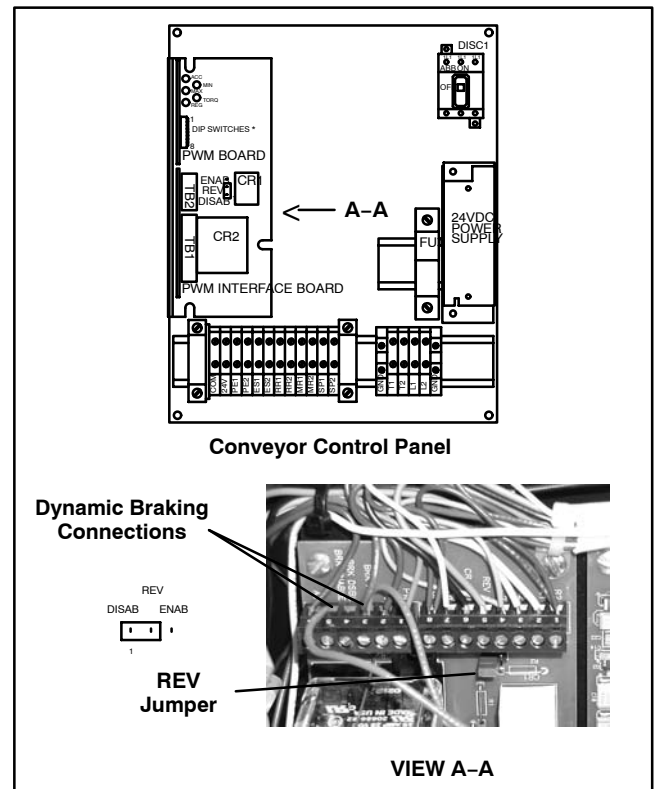

**Figure 9: Controller Setup**

#### 2. Dynamic Braking

“Dynamic Braking” is a means of slowing down a motor after the controller is turned off.



This function is accomplished by attaching a resistor across the armature of the motor to help dissipate the energy being generated by the motor while the motor is coasting to a stop. The *impac* 100 control is shipped with the “Dynamic Braking” function enabled. The dynamic braking function can be disabled as follows:

Locate terminal block (TB1) on the PWM Interface Board (see Figure 9). Remove the orange wire from the terminal labeled “BRK-ENBL” (terminal 5). Re-attach that wire to the terminal label “BRK-DSBL” (terminal 4). This will remove the Dynamic Braking resistor from the circuit.

# impac 100 Operating & Installation Manual

## Variable Speed DC Motors, Single-Phase

### 5.9 Controlling the Speed with an External Reference Signal



	<b>WARNING</b>	
<b>Any external signal or equipment connected to the control must be electronically (e.g., optically) isolated. Using signals which are not isolated can damage the drive control board and/or any external equipment.</b>		

The *impac* 100 control is shipped with the speed potentiometer on the front of the control as the only method to vary the speed of the motor. Some applications may require that the speed of the motor be controlled by another machine or controller. A 0 to 10 Volt *isolated* speed signal may be used to control the speed of the motor in place of the speed potentiometer on the front of the controller. To connect an external speed reference:

- Locate terminal block (TB1) on the PWM Interface Board (see Figure 9).
- Remove the orange wire from the terminal labeled “PW” (terminal 1).
- Tape the end of the exposed wire to avoid shorting to adjacent devices.
- Locate terminal block (TB2) on the PWM Interface Board (see Figure 9).
- Remove the brown wire at the terminal labeled “PL” (terminal 8) that goes to the speed potentiometer on the front of the controll. Be sure that the other brown wire remains connected to the terminal block.
- Tape the end of the exposed wire to avoid shorting to adjacent devices.
- Connect the external signal V+ to the terminal labeled “PW” (TB1, terminal 1).
- Connect the external signal V- to the terminal labeled “PL” (TB2, terminal 8).

The speed pot on the door of the *impac* controller is now disabled.

### 6.0 Implementing Conveyor Control Applications

	<b>WARNING</b>	
<b>Before installing and wiring any accessory kits, remove power to the <i>impac</i> 100 Conveyor Controller by unplugging the <i>impac</i> Conveyor Controller from the power source.</b>		

The *impac* 100 control circuit is designed to support electrical interconnections to a variety of accessory kits (photo-eyes, E-stops, jog buttons, foot switches, E-stop pull cord units, process machine/PLC/PC dry contact interface, and more). The kits are connected to the *impac* 100 using convenient terminal point connections inside the controller. This allows the user to interconnect the kits to fit specific application control needs.

A simplified version of the *impac* 100 control circuit is shown in Figure 10. Four groupings of terminal point connections have been provided for connecting all *impac* accessory kits.

- The first group (**COM-24V**) provides 24 volts D.C. power for any accessory kits that need power (photo-eyes, illuminated pushbuttons, etc.).
- The next group (**PE1-PE2, ES1-ES2, and RR1-RR2**) provide three sets of control points for wiring accessory kits into the *impac* 100 control circuit. Each group is configured with a jumper when the *impac* 100 controller is shipped. When an accessory kit is to be installed the jumper is removed and the kit connected. Each set of control points represents a “series” connection to the *impac* 100 control circuit. When accessory kits are wired in “series” it means that all connected accessories must be “on” for the conveyor to run. For example, if an accessory kit is wired to **PE1-PE2** and another accessory kit is wired to **ES1-ES2**, then both accessories must be “on” for the conveyor to run.

The *impac* 100 controller also supports wiring *impac* accessory kits in “parallel”. When an accessory kit is wired in “parallel” it means “if either” accessory kit is “on” then run the conveyor. Accessories connected in parallel are connected to the same *impac* 100 terminal points.

For example, if two accessory kits are wired to **PE1-PE2** then when either kit is “on” the conveyor will run. Any number of *impac* accessories can be configured in any of the above series and parallel combinations.

- The third group of terminals (**MR1-MR2**) provide an output contact (dry contact) that is closed when the conveyor is running. This can be used to link multiple conveyor operations together or to provide status back to a host controller.
- The last group of terminals (**SP1-SP2**) are two spare terminal points that the user can use for extra termination points for accessory kit wiring.

To select, configure, and implement a conveyor control application using the *impac* 100 Conveyor Controller and *impac* Accessory Kits perform the following steps.

- Remove power to the *impac* Conveyor Controller.**

Before installing and wiring any accessory kits, Remove power to the *impac* controller by unplugging the *impac* controller from the power source.

# impac 100 Operating & Installation Manual

## Variable Speed DC Motors, Single-Phase

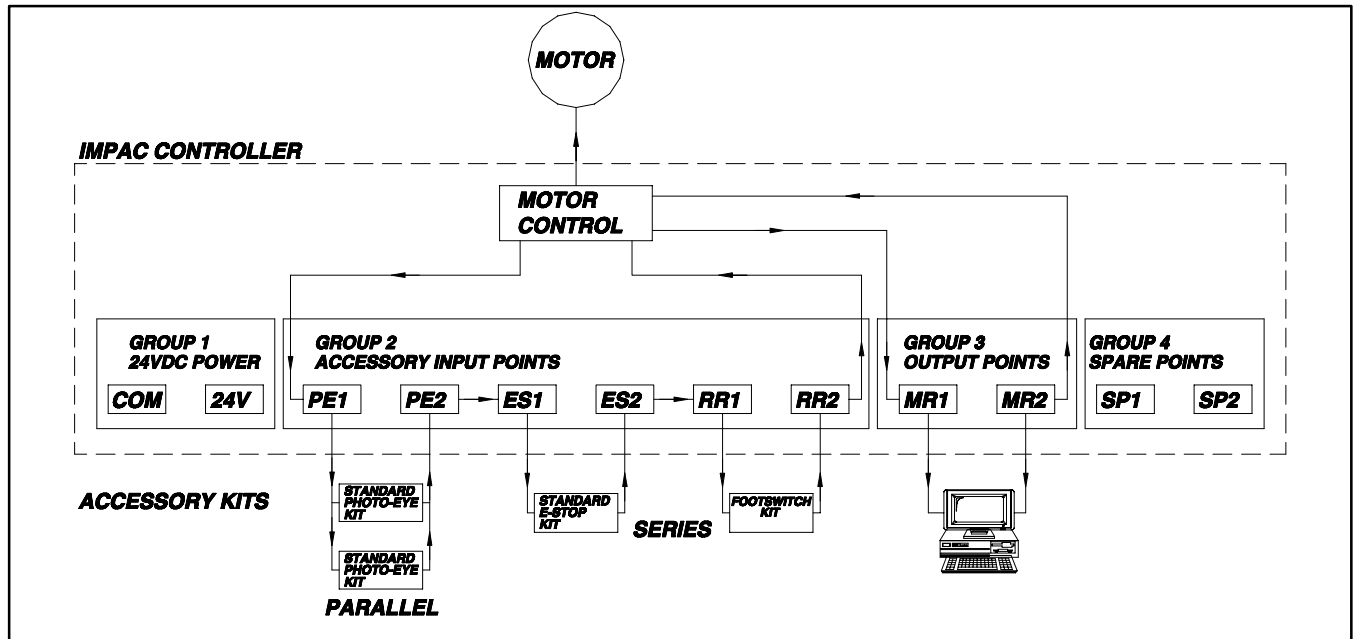

**Figure 10: Simplified impac 100 Control Circuit**

**2. Select Desired Control Application from the Dorner impac 100 Application Guide.**

Included with the *impac* 100 Application Guide are a list of conveyor control application examples that detail the following for many different conveyor control applications:

- A description of the conveyor application control requirements
- An illustration of the conveyor with the *impac* 100 controller and *impac* accessory kits mounted
- A list of hardware required to implement the control application described
- A description of the conveyor operation
- Detailed conveyor control setup instructions
- Illustration that shows how all accessory devices are connected to the *impac* 100 controller

Based on review of the Dorner *impac* 100 Application Guide select the application example that meets the needs of the end-user application. If required, make any final adjustments to the application accessory kit control connections needed by your particular application.

**3. Install all required impac accessory kits**

Install all accessory kits required for the application. The selected Application Example in the Dorner *impac* 100 Application Guide will show the general area of where the kits are to be located on the conveyor. Follow the *impac* Accessory kit Setup & Installation Guide for mounting and cable routing details.

Each *impac* accessory kit includes: Setup & Installation Guide; brackets for mounting; cabling to wire the unit to an *impac* 100 controller; and instructions for mounting/wiring/operating the unit. There are two 1/2" NPT knockouts available for accessory kit installation at the bottom on the controller. Remove the rubber seal, and install the accessory kit cable using the cord grip provided with the kit. The only wiring that is required will be at the accessory terminal block inside the controller. A 1/8" (3 mm) flat blade screwdriver is shipped with the controller for wiring to the terminal block.

**4. Connect the impac accessory kits to the impac 100 Conveyor Controller**

From the selected Application Example in the Dorner *impac* 100 Application Guide Connect the *impac* accessory kit cables to the *impac* controller terminal block as detailed in the application "Setup" description.

**5. Verify proper conveyor operation**

Test and operate the application based on the information detailed in the selected application "Operation & Test" description.

**6. File copy of the Control Application Documentation**

Place a copy of the Conveyor Control Application Example, that was used in step 4, inside *impac* 100 controller.

# impac 100 Operating & Installation Manual

## Variable Speed DC Motors, Single-Phase

### 7.0 Operating the Conveyor Controller

#### — 7.1 Starting the Controller

The conveyor will be “ready to run” when the *impac* ON/OFF disconnect switch is turned ON. The POWER light will be illuminated whenever power is applied to the Conveyor Controller and the ON/OFF disconnect switch is turned ON. If there are no *impac* accessory kits installed, the conveyor will run. If there is(are) any installed accessory kit(s), the conveyor may run, depending on the “ON/OFF” state of the accessory kit(s). When an accessory kit or kits allow the conveyor to run, the MOTOR RUNNING light will be illuminated and the motor will run.

#### — 7.2 Stopping the Controller

Turn the *impac* ON/OFF disconnect switch to OFF to stop the conveyor. The POWER light will not be illuminated whenever power is removed from the Conveyor Controller or the ON/OFF disconnect switch is turned OFF. If there are installed accessory kit(s), the conveyor may stop running, depending on the state of the accessory kits. When an accessory kit prohibits the conveyor from running, the MOTOR RUNNING light will not be illuminated and the motor will stop.

### 8.0 Troubleshooting

PROBLEM	CAUSE	CORRECTION
Motor will not run – MOTOR RUNNING indicator is illuminated – POWER indicator is illuminated	Open wiring connection between <i>impac</i> 100 and motor.  Motor Cord is not connected to motor  Defective motor	Remove any power and, using appropriate means, check continuity and integrity of wiring.  Properly connect motor cord.  Replace motor.
Motor will not run – MOTOR RUNNING indicator is not illuminated – POWER indicator is illuminated – Power Supply LED is ON.	One or more accessory kits are not working properly which is causing an OPEN contact.  One or more accessory kit jumpers, at <i>impac</i> 100 are removed and kit Devices are not installed, or are incorrectly installed.	Check and properly install and wire accessory kits per the Setup & Installation Guide information provided with kit.  Properly install and wire accessory kits per the Setup & Installation Guide information provided with kit.
Motor will not run – MOTOR RUNNING indicator is not illuminated – POWER indicator is illuminated – Power Supply LED is OFF.	Power supply fuse has blown.  One or more accessory kits are incorrectly installed and thus shutting-down the power supply.	Replace with correct amperage and type of fuse.  Properly install and wire accessory kits per the Setup & Installation Guide information provided with kit.
Motor will not run – MOTOR RUNNING indicator is not illuminated – POWER indicator is not illuminated	No power to <i>impac</i> 100 or <i>impac</i> 100 is not plugged-in.  Blown line fuse FU1.	Check all related wiring and make sure <i>impac</i> 100 power cord is plugged-in.  Replace with correct amperage and type of fuse.

# *impac* 100 Operating & Installation Manual

## Variable Speed DC Motors, Single-Phase

PROBLEM	CAUSE	CORRECTION
Motor runs unexpectedly – MOTOR RUNNING indicator is illuminated – POWER indicator is illuminated.	One or more accessory kits are incorrectly installed.  One or more accessory kit jumpers, at <i>impac</i> 100, is/are not correctly installed.	Properly install and wire accessory kits per the Setup & Installation Guide information provided with kit.  Properly install and wire appropriate jumpers per the Setup & Installation Guide information provided with kit.
Motor speed will not increase when SPEED Potentiometer is increased.	+24 volts D.C. not present between TB2-1 (R2) and TB2-6 (CR COM) terminals.  “FORWARD-STOP-REVERSE” switch is not in the STOP position.  PWM circuit board is defective.  SPEED potentiometer is shorted or defective.  Wiring connections are loose.	Test for cause of no voltage and make necessary repairs.  Move switch to STOP position.  Replace PWM circuit board.  Locate circuit short or replace potentiometer.  Secure anchor all connections.
Deceleration time is too long.	+24 volts D.C. not present between TB2-1 (R2) and TB2-6 (CR COM) terminals.  Brake resistor (R1) is open.  “FORWARD-STOP-REVERSE” switch is defective.  Relay (CR2) is defective.  Relay (CR2) is not proper seated in mounting socket.	Test for cause of no voltage and make necessary repairs.  Replace Brake resistor (R1).  Replace defective “FORWARD-STOP-REVERSE” switch.  Replace defective Relay (CR2).  Securely and properly seat Relay (CR2) in its socket.
Motor will not switch between FORWARD and REVERSE.	+24 volts D.C. not present between TB2-1 (R2) and TB2-6 (CR COM) terminals.  “FORWARD-STOP-REVERSE” switch is defective.  Relay (CR2) is defective.  Relay (CR2) is not proper seated in mounting socket.  “REVERSE” Enable Jumper is in the REVERSE DISABLE position.  Wiring connections are loose.	Test for cause of no voltage and make necessary repairs.  Replace defective “FORWARD-STOP-REVERSE” switch.  Replace defective Relay (CR2).  Securely and properly seat Relay (CR2) in its socket.  Move Jumper to ENABLE position.  Secure anchor all connections.

# *impac* 100 Operating & Installation Manual

## Variable Speed DC Motors, Single-Phase

PROBLEM	CAUSE	CORRECTION
Motor "RUNNING" contact does not give indication.	+24 volts D.C. not present between TB2-1 (R2) and TB2-6 (CR COM) terminals.  Relay (CR2) is defective.  "FORWARD-STOP-REVERSE" (S2) switch is in STOP position.  "FORWARD-STOP-REVERSE" (S2) switch is defective.  Wiring connections are loose.	Test for cause of no voltage and make necessary repairs.  Replace defective Relay (CR2).  Move switch away from STOP position.  Replace defective "FORWARD-STOP-REVERSE" (S2) switch.  Secure anchor all connections.
DC Drive Motor will not turn.	Motor wiring is open.  Current Limit is adjusted to ZERO.  The SPEED potentiometer is open.  Motor is defective.  Circuit board is defective.  Power circuit is defective.	Check and correct open circuit.  Set current Limit to a value greater than ZERO.  Replace SPEED potentiometer.  Replace defective motor.  Replace defective circuit board.  Check and correct power circuit wiring problem.
DC Drive Motor runs too slowly.	The MAXIMUM SPEED adjustment is set too low.  The SPEED potentiometer is open.  Motor is defective.  An overload condition exists.  Circuit board is defective.	Readjust MAXIMUM SPEED to a higher value.  Replace SPEED potentiometer.  Replace defective motor.  Correct overload and reset circuit.  Replace defective circuit board.
DC Drive Motor runs too fast.	The MAXIMUM SPEED adjustment is set too high.  The SPEED potentiometer is defective.  Motor is defective.  Circuit board is defective.	Readjust MAXIMUM SPEED to a higher value.  Replace defective SPEED potentiometer.  Replace defective motor.  Replace defective circuit board.
DC Drive Motor runs too fast, regardless of SPEED setting.	The SPEED potentiometer is defective.  The POWER semiconductor is defective.  Circuit board is defective.	Replace defective SPEED potentiometer.  Replace defective POWER semiconductor.  Replace defective circuit board.

# *impac* 100 Operating & Installation Manual

## Variable Speed DC Motors, Single-Phase

PROBLEM	CAUSE	CORRECTION
DC Drive Motor oscillates.	<p>SPEED REGULATION is adjusted too high.</p> <p>A cyclic overload condition exists.</p> <p>Motor is defective.</p> <p>Wiring connections are loose.</p> <p>Motor commutator is worn.</p> <p>Motor brushes are worn or not making proper connections with commutator.</p> <p>Circuit board is defective.</p>	<p>Readjust SPEED REGULATION to a lower value.</p> <p>Correct cyclic overload condition.</p> <p>Replace defective motor.</p> <p>Secure anchor all connections.</p> <p>Replace motor.</p> <p>Replace motor brushes.</p> <p>Replace defective circuit board.</p>
DC Drive Motor speed varies excessively with load applied.	<p>SPEED REGULATION is adjusted too low.</p> <p>DIP switches are set incorrectly.</p> <p>Motor brushes are worn or not making proper connections with commutator.</p> <p>Wiring connections are loose.</p> <p>Circuit board is defective.</p>	<p>Readjust SPEED REGULATION to a higher value.</p> <p>Reset DIP switches.</p> <p>Replace motor brushes.</p> <p>Secure anchor all connections.</p> <p>Replace defective circuit board.</p>





---

# ***impac* 100 Operating & Installation Manual**

## **Variable Speed DC Motors, Single-Phase**

---

### **Standard Available IMPAC Accessory Kits**

- Standard Photo-Eye Kit, Fixed Mount (75-30)
- Standard Photo-Eye Kit, Adjustable Mount (75-31)
- Timing Photo-Eye Kit, Fixed Mount (75-32)
- Timing Photo-Eye Kit, Adjustable Mount (75-33)
- Emergency Stop Kit, Illuminated (75-40)
- Emergency Stop Kit, Non-Illuminated (75-41)
- Emergency Stop Kit, Pull Cord (75-42)
- Jog Kit (75-10)
- Foot Switch Kit (75-20)
- Start/Stop Kit (75-70)
- Electric Clutch/Brake Kit (75-60)
- Controller to Controller Linking Cable Kit (75-80)
- Wire Way Trough Kits
  - 6-ft (1829 mm) (75-85-6)
  - 12.5-ft (3810 mm) (75-85-12)
- T-slot Extension Kit (307000M)
- Light Duty End Stop Kits
  - 2100 Series (215502M – 215524M)
  - 3100 Series (315504M – 315540M)
- Adjustable Stop Kits (307602M – 307640M)

---

## Return Policy

---

No returns will be accepted without prior written factory authorization. When calling for authorization, please have the following information ready for the Dorner Factory representative or your local distributor:

1. Name and address of customer.
2. Item(s) being returned.
3. Reason for return.
4. Customer's original order number used when ordering the item(s).
5. Dorner or distributor invoice number.

A representative will discuss action to be taken on the Returned items and provide a Returned Goods Authorization Number to reference.

There will be a 15% restocking charge on all new items returned for credit where Dorner was not at fault. These will not be accepted after 60 days from original invoice date. The restocking charge covers inspection, cleaning, disassembly, and reissuing to inventory.

If a replacement is needed prior to evaluation of returned item, a purchase order must be issued. Credit (if any) is issued only after return and evaluation is complete.

Dorner has representatives throughout the world. Feel free to contact Dorner for the name of your local representative. Our technical sales and service staff will gladly help with your questions on Dorner products.

For a copy of Dorner's Limited Warranty, contact factory, distributor, service center or visit our website @ [www.dorner.com](http://www.dorner.com)

**For replacement parts, contact an authorized  
Dorner Service Center or the factory.**

**DORNER<sup>®</sup>**

Dorner Mfg. Corp. reserves the right to change or discontinue products without notice. All products and services are covered in accordance with our standard warranty. All rights reserved. © Dorner Mfg. Corp. 1999

**DORNER MFG. CORP.**

975 Cottonwood Drive, PO Box 20  
Hartland, WI 53029-0020 USA

**USA**

**TEL 1-800-397-8664 (USA)**

**FAX 1-800-369-2440 (USA)**

**Internet: [www.dorner.com](http://www.dorner.com)**

**Outside the USA:**

**TEL 1-262-367-7600**

**FAX 1-262-367-5827**