

Mounting Package Assembly Instructions

3100 Bottom Mounting Packages

This mounting package can be set up in either one of two positions (**A** or **D**, Figure 1).

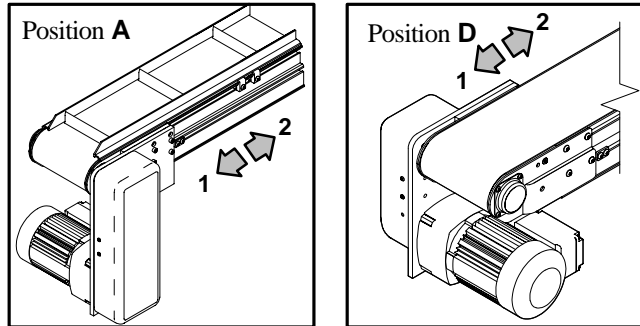

Figure 1: Cleated Belt (left) & Flat Belt (right)

In addition, the conveyor belt can be driven in either one of two directions (**1** or **2**, Figure 2). Arrows show belt travel direction.

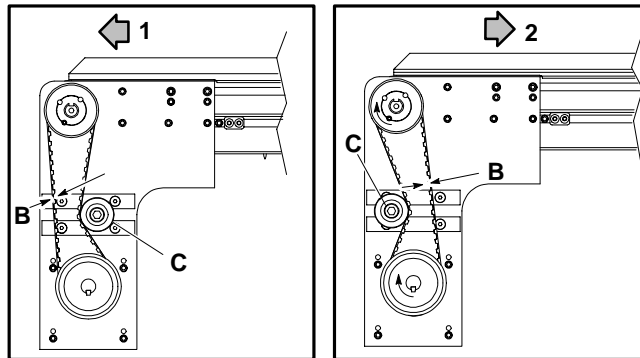

Figure 2

NOTE:

Item numbers shown below correspond with those shown in Figure 3 and on the backside of this instruction sheet.

1. The gearmotor (**E**) and M6 x 25 mm socket head cap screws (**13**), that mount it to mounting plate (**5**), are shown assembled. These pieces are shipped as loose parts.
2. Attach the motor mounting plate to the conveyor (**F**) using one M6 x 30 mm socket head cap screw (**15**) in the top mounting hole of the mounting plate, two M6 x 16 mm socket head cap screws (**21**) in middle holes and three M6 x 20 mm socket head cap screws (**14**) in bottom holes.
3. Attach gearmotor (**E**) to mounting plate using four M6 x 25 mm socket head cap screws (**13**) to secure it in place.

NOTE:

The lower set (of 4) gearmotor mounting plate holes is only used when both gearmotor and conveyor shafts will have 16 tooth pulleys mounted to them. All other pulley combinations, use the upper set of mounting plate holes.

4. Assemble the drive and driven pulleys (**18** and/or **16**) and timing belt (**20**). Place a square key (**1**) into the keyway on the gearmotor and conveyor shafts. Install the pulleys so that timing belt is centered on the belt tensioning roller assembly and the pulleys are in line with each other. Tighten the pulley set screws (**19**) or Taper Lock[®] bushing screws (**17**), which fasten the pulleys to the shafts. Determine which direction the conveyor belt is traveling and position the tensioning roller assembly on slack side of the timing belt.
5. Adjust timing belt tension by loosening the M12 x 25 mm socket head cap screw (**12**) and sliding the belt tensioning roller assembly against the belt. Tension should be measured at mid-point (**B**) on the tension side of the timing belt. As a starting point for the tensioning process, there should be a 1/8" (3 mm) deflection with 6 lb (3kg or 26 N) of force.
6. Every timing belt application exhibits its own individual operating characteristics. The optimum timing belt tension should be determined experimentally. If necessary, continue to slide the tensioning roller assembly against the timing belt until the belt is tensioned so as to prevent jumping of teeth under the most severe conditions which the drive will encounter. Tighten the M12 x 25 mm socket head cap screw after tension requirements are achieved.

IMPORTANT:

Do not over tension the timing belt. Over tensioning may cause reduced belt life or bearing and drive damage.

7. Attach the top drive cover (**2**) using four M4 x 10 mm button head cap screws (**3**).

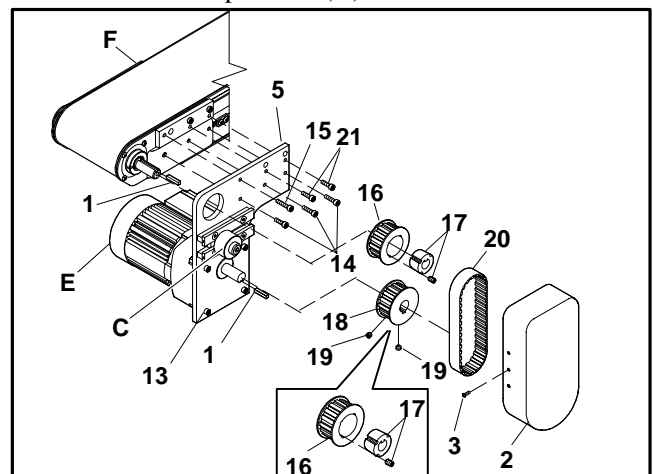
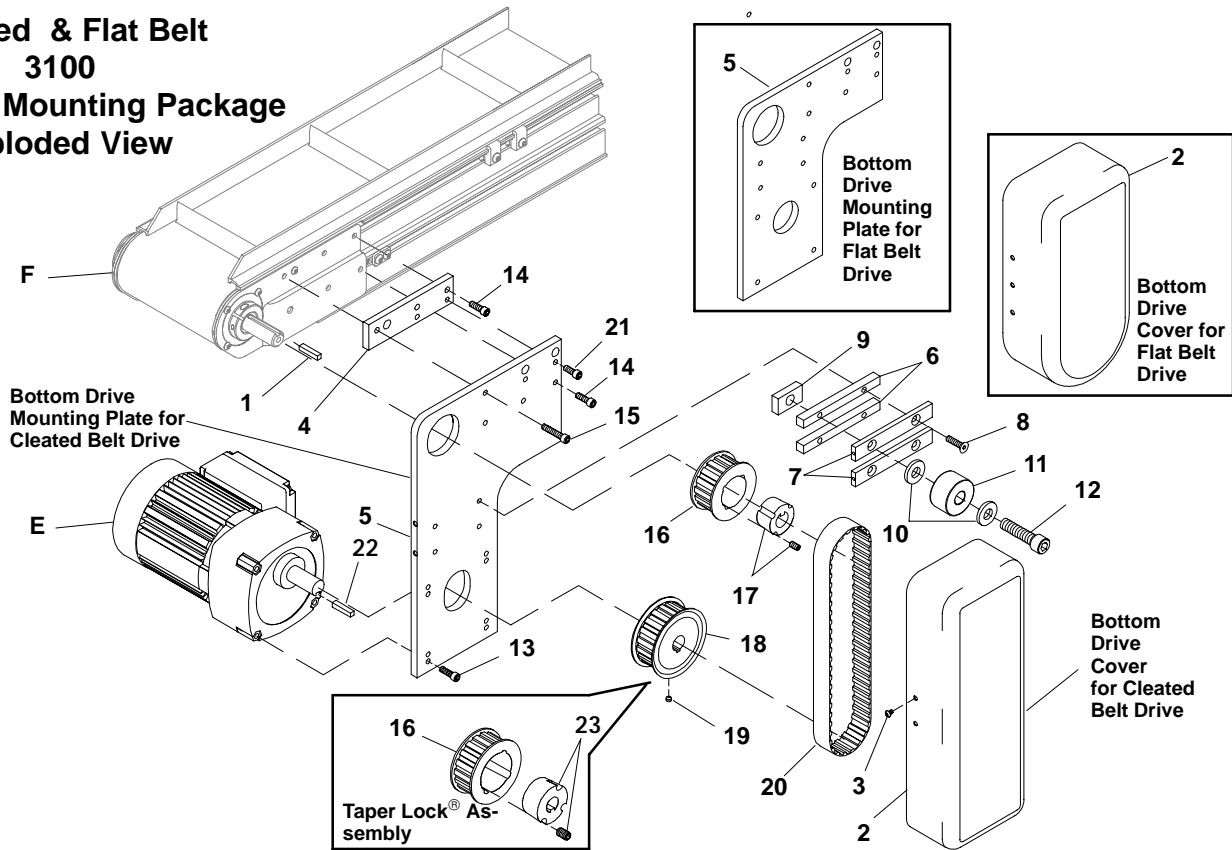

Figure 3: Sample Flat Belt Bottom Drive

Mounting Package Assembly Instructions

Cleated & Flat Belt 3100 Bottom Mounting Package Exploded View



Item	Part No.	Part Description
1	980018M	Square Key (Undersized), 6 mm x 18 mm
2	300871M 300349M	Bottom Drive Cover (Cleated Belt) Bottom Drive Cover (Flat Belt)
3	910410M	Button Head Cap Screw, M4-0.70 x 10 mm
4	300038M	Spacer, 3/8 Thick
5	310035M 310037M	Drive Bottom Mounting Plate (Cleated Belt) Drive Bottom Mounting Plate (Flat Belt)
6	300187	Idler Spacer Bar
7	300186M	Idler Guide Bar
8	930625M	Flat Head Cap Screw, M6-1.0 x 25 mm
9	628144M	Cam Follower Nut
10	605284	Hard Washer, Black Oxide
11	802-059	Cam Follower Bearing
12	921250M	Socket Head Cap Screw, M12-1.75 x 50 mm
13	902-157	Socket Head Cap Screw, 1/4-28 x 3/4"
14	920620M	Socket Head Cap Screw, M6-1.0 x 20 mm
15	920630M	Socket Head Cap Screw, M6-1.0 x 30 mm

Item	Part No.	Part Description
16	811-126 811-127 811-133 811-135 811-136 811-137	Pulley, 16 Tooth, Taper Lock®-TL1108 Pulley, 18 Tooth, Taper Lock®-TL1210 Pulley, 14 Tooth, Taper Lock®-TL1108 Pulley, 20 Tooth, Taper Lock®-TL1210 Pulley, 22 Tooth, Taper Lock®-TL1610 Pulley, 24 Tooth, Taper Lock®-TL1610
17	811-204	Taper Lock® Bushing-TL1108, 19 mm Bore
18	300549	Drive Pulley, 19 Tooth, 3/4" Bore
19	907-141	Socket Head Set Screw, 1/4-28 x 1/4"
20	814-047 814-048 814-057 814-059 814-060	Timing Belt, 21" (533.4 mm) Long (for Flat Belt Conveyor) Timing Belt, 22" (558.8 mm) Long (for Flat Belt Conveyor) Timing Belt, 23" (584.2 mm) Long (for Flat Belt Conveyor) Timing Belt, 27" (685 mm) Long (for Cleated Belt Conveyor) Timing Belt, 28" (711 mm) Long (for Cleated Belt Conveyor)
21	920616M	Socket Head Cap Screw, M6-1.0 x 16 mm
22	912-078	Key, 3/16" x 3/4" Long
23	811-167 811-074	Taper Lock Bushing TL-1610, 3/4" Bore Taper Lock Bushing TL-1210, 3/4" Bore

DORNER®

Dorner Mfg. Corp. reserves the right to change or discontinue products without notice. All products and services are covered in accordance with our standard warranty. All rights reserved. ©Dorner Mfg. Corp. 1997

DORNER MFG. CORP.

975 Cottonwood Ave., PO Box 20
Hartland, WI 53029-0020 USA

USA

TEL 1-800-397-8664 (USA)

FAX 1-800-369-2440 (USA)

Outside the USA:

TEL 1-414-367-7600, FAX 1-414-367-5827

DORNER

Arnold-Sommerfeld-Ring 2
D-52499 Baesweiler

Germany

TEL (02401) 80 52 90

FAX (02401) 80 52 93