

DORNER[®]

LPZ Standard & Sidewall Cleated Belt Conveyors

Parts, Assembly & Maintenance Manual

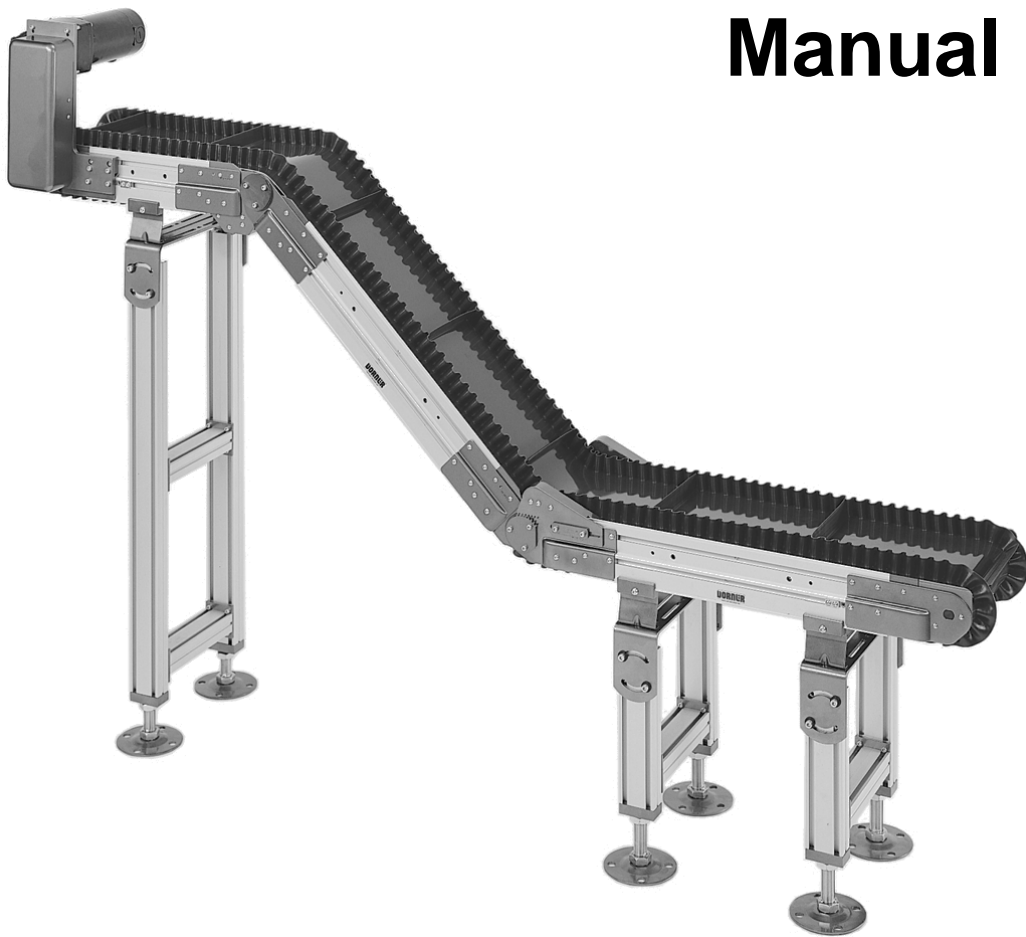

Table of Contents

Safe Practices	3	Conveyor Belt Removal	18
Foreword	3	For Conveyor on Fully Adjustable Aluminum Support Stand	18
Installation Instructions		For Conveyor on Aluminum or Steel Support Stand	18
Introduction	4	Conveyor Belt Replacement	19
General Instructions	4	Troubleshooting Guide	
Conveyor Re-assembly for 14 ft (4.3m) and Shorter Units	4	Gearmotors	20
Conveyor Re-assembly for Longer than 14 ft (4.3m) Units	4	Timing Belt	20
Initial Angle Adjustments	6	Conveyor Belt	20
Nose-over Configuration	6	Replacement Parts	
Horizontal to Incline Configuration	7	Standard Duty Intermediate Assemblies	22
Drive Package Installation		Light Duty Intermediate Assemblies	24
Bottom Mount Installation & Initial Timing Belt Tension Adjustment	8	Standard Drive End with Powered Pulley	25
Top Mount Installation & Initial Timing Belt Tension Adjustment	9	Tail Assemblies	
Side Mount Installation	11	Drive End	26
Horizontal Infeed Chutes & Backstop	12	Tension End	28
Start-up & Preliminary Adjustments		Transition Module Assemblies	
Conveyor Belt Tension	13	Nose-over	30
Conveyor Belt Tracking Adjustment Procedure ...	14	Horizontal to Incline	32
Maintenance, Conveyor Belt	15	Standard Cleated Belt Conveyor Guiding	34
Conveyor Belt Replacement		Standard Gearmotor Packages	
& Adjustments		Cleated Belt Bottom Mounting	39
Conveyor Preparations	16	Cleated Belt Side Mounting	40
Standard Cleated Belt Conveyor Guiding	16	Cleated Belt Top Mounting	41
Releasing Conveyor Belt Tension	16	Gearmotors and Variable Speed Motors & Controllers	42
Conveyor Belt Guide Rollers	17	Chute Assemblies, Backstop Assemblies & Mounting Components	43
Guide Roller Assembly for Nose-over Transitions	17	Conveyor Belt	44
Guide Roller Assembly for Horizontal to Incline Transitions	17	Tool Kit	44
		Numerical Index	45

! WARNING !

- The safety alert symbol, black triangle with white exclamation, is used to alert you to potential personal injury hazards.
- Standing on a conveyor or transporting people is prohibited.
- When conveyors are used in conjunction with other equipment or as part of a multiple conveyor system, check for potential pinch points and other mechanical hazards before system start-up. Because Dorner Mfg. Corp. cannot control the physical installation and applications of multiple conveyor systems, taking protective measures is the responsibility of the user.
- Operating Dorner conveyors in an explosive environment is prohibited.
- NEVER operate equipment without guards or other protective devices properly secured in place. In addition, to prevent injury, make sure all electrical and pneumatic power sources have been disconnected and locked-out before you perform any maintenance, make any adjustments or replace any components.
- Some gearmotors may operate at an elevated temperature which may cause people to be startled if they accidentally touch the motor housing.
- Before proceeding to loosen hardware that locks-in the selected stand height, be sure that all related Conveyor sections are securely supported to prevent them from moving suddenly and dropping-down which may pinch or strike you, causing serious personal injury.
- Although all potentially hazardous areas of the Cleated Belt conveyors are shielded by bolt-on guards and there are no exposed pinch-point, the cleats themselves may create unforeseen catch points, especially when loose-fitting clothing is being worn. Exercise appropriate caution everywhere around the cleated belt.

Foreword

By following the maintenance and adjustment instructions in this manual, you will prolong the life of your conveyor and maintain its maximum efficiency.

When ordering replacement parts, always give the model and serial number. These numbers are stamped on a nameplate label (Figure 1), located on conveyor side rail. Record the numbers below for ready reference.

Model Number _____
(Fill In)

Serial Number _____
(Fill In)

NOTE:

All technical data in this publication is based on the product information available at time of printing. All assemblies are fastened with metric mounting hardware. Dorner reserves the right to make changes at any time without notice or obligation to install those changes on units previously delivered.

For pictorial clarity, some illustrations in this manual may show guards or other protective devices open or removed. Under no circumstances should the conveyor be operated without these devices securely in place.

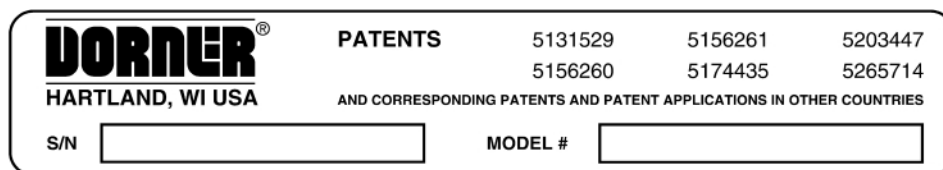

Figure 1: Typical Model & Order Number Nameplate Label

PZ01

Installation Instructions

Introduction

LPZ Cleated Belt Conveyors are adjustable angle conveyors designed to meet a variety of material handling applications.

These conveyors feature an adjustable frame that is easily set up and configured to meet a variety of manufacturing, assembly and bulk handling requirements. The three choices of available configuration are: Nose-over, Horizontal to Incline and, Z-frame.

Two cleated conveyor belt styles are available: Standard Cleated belt with a choice of any one of 8 different types of cleats or Sidewall Cleated belt with a choice of either 1" (25 mm) or 1.4" (35 mm) high sidewalls and cleats.

To compliment the feature and function of the LPZ cleated belt conveyors, all three adjustable angle configurations can be combined with fully adjustable aluminum support stands, standard aluminum support stands, or steel support stands. All stands are available with casters.

General Instructions

Use Dorner stands and compatible mounting hardware to squarely, straightly and securely support the conveyor. Refer to separate Metric Support Stands & Conveyor Mountings Parts, Assembly & Maintenance Manual, for additional information. When properly set-up, each conveyor section must be free of any twist, regardless of overall conveyor length, width and/or configuration. This is done by checking the alignment of the side rails. One method of checking rail alignment is as follows (refer to Figure 2):

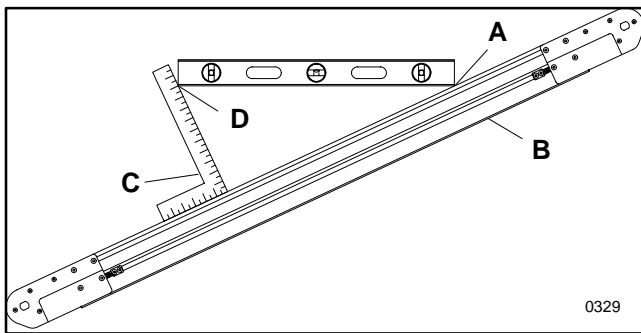

Figure 2: LPZ Section Alignment Detail

1. Place the corner of the level (A of Figure 2) against the upper end of the side rail (B) (on either side of the conveyor). Re-position the level until exact horizontal is obtained.
2. Place a square (C) along the lower end of the side rail (on same side as level) and measure the distance (D), at right angle from the conveyor to the edge of the level.
3. Using the level and square, repeat steps 1 & 2 for the opposite side rail.

If measurements are not the same for both sides, adjust the appropriate stand or support up or down to bring both side rails into exact alignment.

4. Repeat the alignment process for all sections to the complete LPZ conveyor.

Conveyors Re-assembly for 14 ft (4.3 m) and Shorter Units

NOTE:

Conveyors 14 ft (4.3 m) and shorter are shipped from factory assembled in flat position and conveyor belt is installed.

Conveyors measuring 14 ft (4.3 m) and shorter are configured and built at the factory, laid flat and shipped as an assembly in one container. Perform the following steps to uncrate the unit and prepare it for operation:

1. Using appropriate lifting means, carefully remove the assembly from the wooden shipping box and place it in its correct operating position and direction.
2. Adjust and temporarily secure the transition modules into the approximate angles. See the "Angle Adjustments" topic on page 7, for additional information.
3. Re-position and adjust the stand mounting brackets, if necessary. Then, attach the conveyor to the appropriate elements of the support stands. Refer to separate Metric Support Stands & Conveyor Mountings Parts, Assembly & Maintenance Manual, for additional information.
4. Install the drive mounting package and make the timing belt adjustments, as applicable, following the appropriate "Drive Package Installation" subtopic beginning on page 9. For maximum load carrying, locate the gearmotor so that what is being conveyed moves toward the drive.
5. Some gearmotors will require some customer-provided electrical wiring. Follow all applicable local electrical codes and the wiring diagrams, supplied with the gearmotors. The wiring diagram, for a three-phase gearmotor, is located inside the terminal box which is attached to the gearmotor. The wiring diagram for a variable speed gearmotors is located inside the control box.
6. Perform initial conveyor belt tension and tracking adjustment following the information provided. See the "Conveyor Belt Tension" topic of page 14 and the "Conveyor Belt Tracking Adjustment Procedure" topic of page 15.
7. If provided, install the accessory infeed chute following details under the Infeed Chute topic on page 13.

Conveyors Re-assembly for Longer than 14 ft (4.3 m) Units

NOTE:

Conveyors over 14 ft (4.3 m) long are factory assembled and then broken down for shipment.

Conveyors measuring 14 to 25 ft (4.3 to 6.4 m) are configured and built at the factory and partially disassembled, crated and shipped in sections. Perform the following steps to uncrate and

re-assemble the sections into a ready-to-operate complete conveyor assembly:

1. Using appropriate lifting means, carefully remove the various sections, from their wooden shipping boxes, and position them into the correct position, sequence and operating direction.
2. **On Standard Cleated belt conveyors only**, note the position, direction and anchoring of all guiding sections and temporarily detach them from each conveyor section by loosening the guide clamps (A of Figure 3).

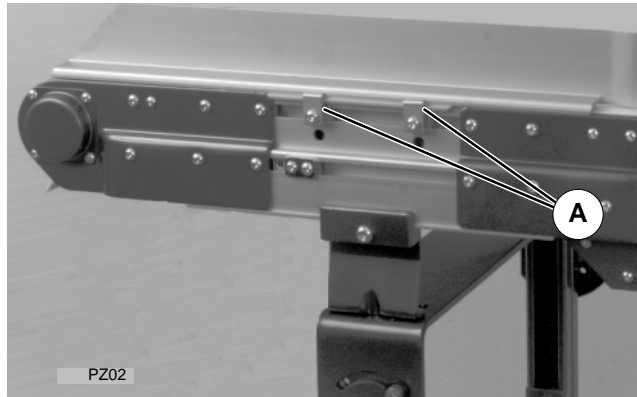

Figure 3: LPZ Standard Cleated Belt Conveyor Guide Attachment Detail

3. To facilitate conveyor belt installation, temporarily remove the belt guide rollers from both sides of the conveyor. The belt guide rollers are located on the nose-over transition assemblies and/or the horizontal to incline transition assemblies. For specific details, refer to the “Conveyor Belt Guide Rollers” topic on page 17.
4. Starting with the section which has conveyor belt attached, re-position and adjust the stand mounting brackets, if necessary. Then, temporarily assemble that section onto the stands or supports. Refer to separate Metric Support Stands & Conveyor Mountings Parts, Assembly & Maintenance Manual, for additional information.
5. Unroll the conveyor belt and place it to one side of the conveyor.
6. Adjust and temporarily secure the transition modules at their like-final angles. See the “Angle Adjustments” topic on page 7, for additional information.
7. With the remaining sections, reposition and adjust the stand mounting brackets, if necessary. Then, adjust and temporarily secure the transition modules in their approximate angles. See the “Angle Adjustments” topic on page 7, for additional information. Then, temporarily assemble these sections onto their stands and stand mounting brackets. Refer to separate Metric Support Stands & Conveyor Mountings Parts, Assembly & Maintenance Manual, for additional information.

NOTE:

To best enable connections between conveyor modules and sections of standard cleated belt conveyors only, temporarily unclamp and remove all of the guiding.

8. Refer to Figure 4 and connect adjoining LPZ sections in the following manner:
 - a. Loosen (but not remove) the four (4) M6 x 12 mm cap screws (B of Figure 4), on both sides of the conveyor.
 - b. Bring both conveyor sections into close proximity and align the T-bars (D) with the T-slots (C) in the adjoining conveyor section.
 - c. While guiding the T-bars into the T-slots, slide the transition module of the one conveyor section into the open-end of the other conveyor section.
 - d. Continue to move the two sections together until the inner plates contact.
 - e. Tightly secure all four M6 x 12 mm cap screws, on both sides of the conveyor.

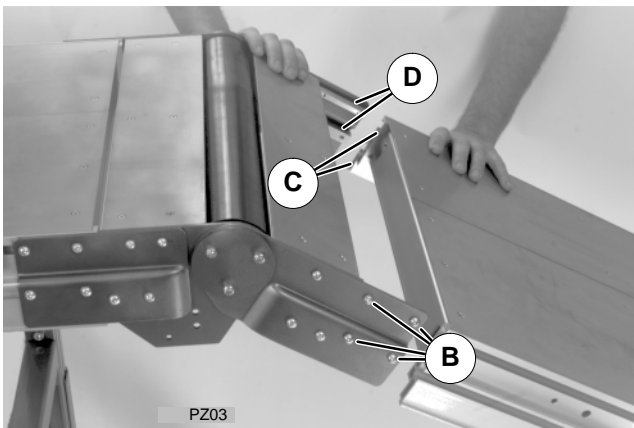

Figure 4: LPZ Section Connection Detail

9. Install the conveyor belt around the sections. For these procedures, refer to the Conveyor Belt Replacement topic on page 20.



After the conveyor belt has been slid into position, be sure to reconnect and re-secure the same mounting bracket and attaching hardware to securely re-anchor the stand to the conveyor.
10. **On Standard Cleated belt conveyors only**, replace the guiding, following details described under the “Standard Cleated Belt Conveyor Guiding” topic on page 17.
11. Install drive mounting package and make the timing belt adjustments, as applicable, following the appropriate “Drive Package Installation” subtopic beginning on page 9.
12. Perform initial conveyor belt tension and tracking adjustment following the information provided. See the “Conveyor Belt Tension” topic of page 14 and the “Conveyor Belt Tracking Adjustment Procedure” topic of page 15.
13. As applicable, install the accessory infeed chute following details on page 13.

Installation Instructions

Angle Adjustments

All LPZ Conveyors are shipped flat in wooden crates. After uncrating and in consideration of their final mounted and supported position, the transition assemblies should be adjusted to the desired angle. The components which form the transition assemblies are similar for either the standard cleated or sidewall cleated conveyors. One major difference is whether the conveyor is a “nose-over” or a “horizontal-to-incline” configuration. As appropriate, make the necessary initial angle adjustments according to information provided under the appropriate sub-heading.

Nose-over Configuration

 **WARNING** 

Before loosening or removing any of the Angle Adjustment Screws (A of Figure 5), make sure that all related Conveyor sections are securely supported and prevented from suddenly moving and dropping-down. This movement could cause serious personal injury.

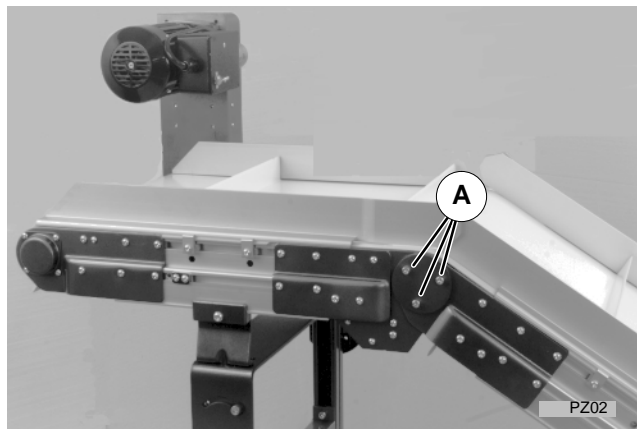

Figure 5: LPZ Nose-over Angle Adjustment Detail

Perform the nose-over angle adjustments as follows:

1. Loosen (but do not remove) the conveyor tail cover plate clamp screws and the belt tracking cam assembly clamp screws. Refer to the “Releasing Conveyor Belt Tension” topic of page 17, for additional details.

NOTE:

Special-colored “0° Angle” screws must be removed when making the initial adjustment from (or to) the (0°) shipping position. When sections of conveyor are flat, the “0° Angle” screw locks-out and prevents operation between 0° and 25°. Special-colored “0° Angle” screws need only to be loosened, when making the “transition angle” (see table on page 14) adjustments. LPZ conveyors should never be operated with the “0° Angle” screws removed.

2. Refer to Figure 6 and remove and retain the special-colored, “0° Angle” screws (B) from the pivot discs on both sides of the conveyor.

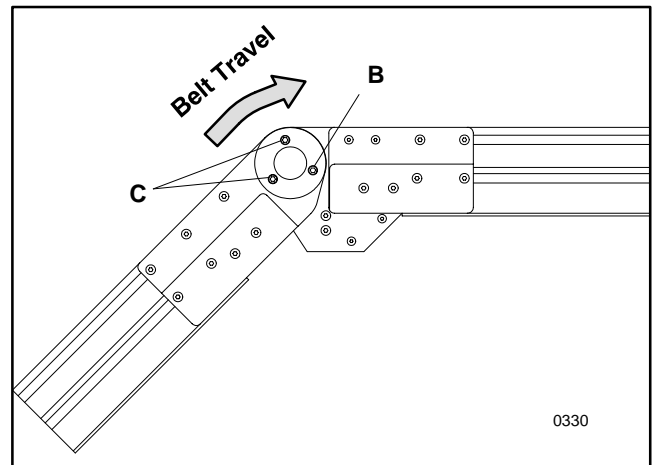

Figure 6: Sample Nose-over or Upper Z-Frame Angle Adjustment Detail

3. With the special-colored “0° Angle” screws removed, loosen (but do not remove) the other two (2) screws (C) from the pivot disc.
4. Pivot the section to the required angle and tighten the two adjustment screws (loosened in the step 3). Also, replace (as applicable) and re-secure the special-colored, “0° Angle” screws.
5. Restore proper conveyor belt tension and tracking. See the “Conveyor Belt Tension” topic of page 14 and the “Conveyor Belt Tracking Adjustment Procedure” topic of page 15.

Installation Instructions

Horizontal to Incline Configuration

Perform the horizontal to incline angle adjustments as follows:

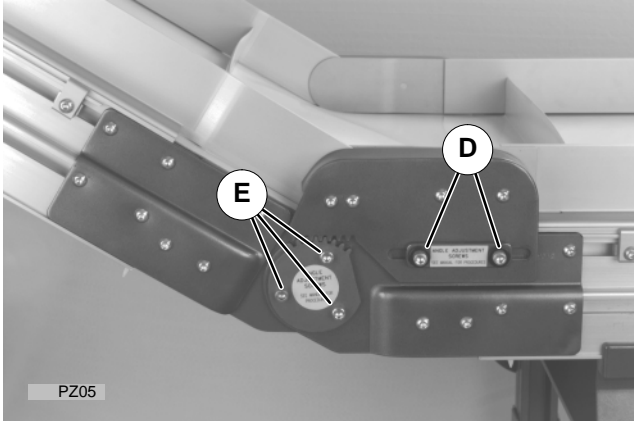



Figure 7: LPZ Horizontal to Incline Angle Adjustment Detail

**WARNING**

Before loosening or removing any of the Angle Adjustment Screws (D & E of Figure 7), make sure that all related Conveyor sections are securely supported and prevented from suddenly moving and dropping-down. This movement could cause serious personal injury.

1. Loosen (but do not remove) the conveyor tail cover plate clamp screws and the belt tracking cam assembly clamp screws. Refer to the “Releasing Conveyor Belt Tension” topic of page 17, for additional details.

NOTE:

Special-colored “0° Angle” screws must be removed when making the initial adjustment from (or to) the (0°) shipping position. When sections of conveyor are flat, the “0° Angle” screw locks-out and prevents operation between 0° and 25°. Special-colored “0° Angle” screws need only to be loosened, when making the “transition angle” (see table on page 14) adjustments. LPZ conveyors should never be operated with the “0° Angle” screws removed.

2. Refer to Figure 8 and remove and retain the special-colored, “0° Angle” screws (F) from the pivot gear on both sides of the conveyor.

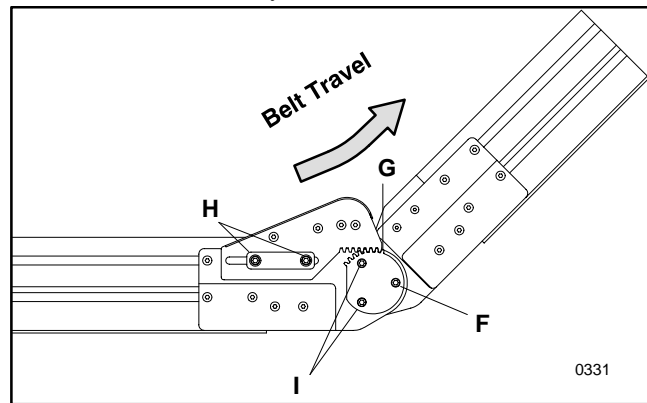

Figure 8: Horizontal to Incline or Lower Z-Frame Angle Adjustment Detail

3. With the special-colored “0° Angle” screws removed, loosen (but do not remove) the other two (2) screws (I) from the pivot gear (G).
4. With the special-colored “0° Angle” screws removed, also loosen (but do not remove) the two (2) screws from the top roller slide plate (H) on both sides of the conveyor.
5. Pivot the section to the required angle and tighten the adjustment screws which were loosened in the steps 3 & 4. Then, replace (as applicable) and re-secure the special-colored, “0° Angle” screws.
6. Restore proper conveyor belt tension and tracking. See the “Conveyor Belt Tension” topic of page 14 and the “Conveyor Belt Tracking Adjustment Procedure” topic of page 15.

Installation Instructions

Drive Package Installation

NOTE:

For maximum load carrying, locate the gearmotor so that what is being conveyed moves toward the drive.

Bottom Mount Installation & Initial Timing Belt Tension Adjustment

The bottom mount package can be set up in either one of two positions (A or D of Figure 9).

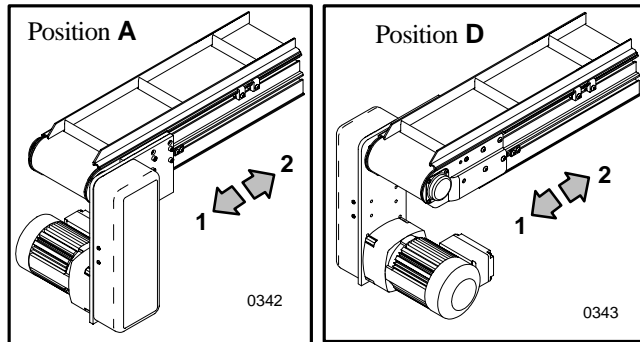

Figure 9: Bottom Drive Mounting Detail

The conveyor belt can be driven in either one of two directions (1 or 2 of Figure 9). Arrows show belt travel direction.

WARNING

Belt travel direction must correspond to arrow decals located on transition sections to prevent the creation of pinch points which could cause serious personal injury.

1. Refer to Figure 11 and attach the gearmotor (E) and the motor mounting plate (H) to the conveyor (F) using one M6 x 30 mm socket head cap screw (I) in the top mounting hole of the mounting plate, two M6 x 16 mm socket head cap screws (J) in middle holes and three M6 x 20 mm socket head cap screws (K) in bottom holes.

NOTE:

The lower set (of 4) gearmotor mounting plate holes (G of of Figure 11) is only used when both gearmotor and conveyor shafts will have 16 tooth pulleys mounted to them. All other pulley combinations, use the upper set of mounting plate holes.

2. Assemble the drive and driven pulleys (M and/or L) and

timing belt (N). Place a square key (O of Figure 11) into the keyway on the gearmotor and conveyor shafts. Install the pulleys so that the timing belt is centered on the belt tensioning roller assembly and the pulleys are in line with each other. Tighten the pulley set screws (Q) or Taper Lock® bushing screws (P), which fasten the pulleys to the shafts. Determine which direction the conveyor belt is traveling and position the tensioning roller assembly on slack side of the timing belt (Figure 10).

3. Adjust timing belt tension by loosening the M12 x 25 mm socket head cap screw (R) and sliding the belt tensioning roller assembly against the belt. Tension should be measured at mid-point (C of Figure 10) on the tension side of the timing belt. As a starting point for the tensioning process, there should be a 1/8" (3 mm) deflection with 6 lb (3kg or 26 N) of force.

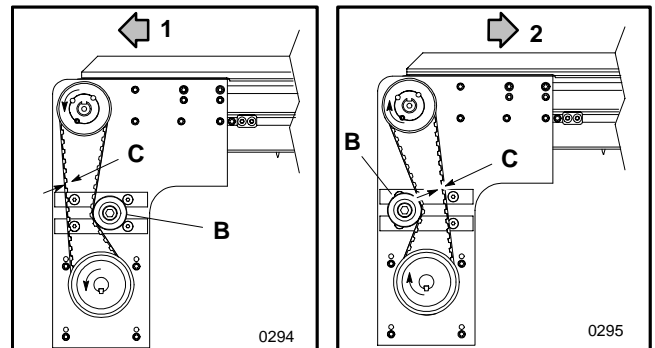

Figure 10: Bottom Drive Timing Belt Adjustment Detail

4. Every timing belt application exhibits its own individual operating characteristics. The optimum timing belt tension should be determined experimentally.

If necessary, continue to slide the tensioning roller assembly against the timing belt until the belt is tensioned so as to prevent jumping of teeth under the most severe conditions which the drive will encounter. Tighten the M12 x 25 mm socket head cap screw after tension requirements are achieved.

IMPORTANT:

Do not over tension the timing belt. Over tensioning may cause reduced belt life or bearing and drive damage.

5. Attach the bottom drive cover (S of Figure 11) using four M4 x 10 mm button head cap screws (T).

Installation Instructions

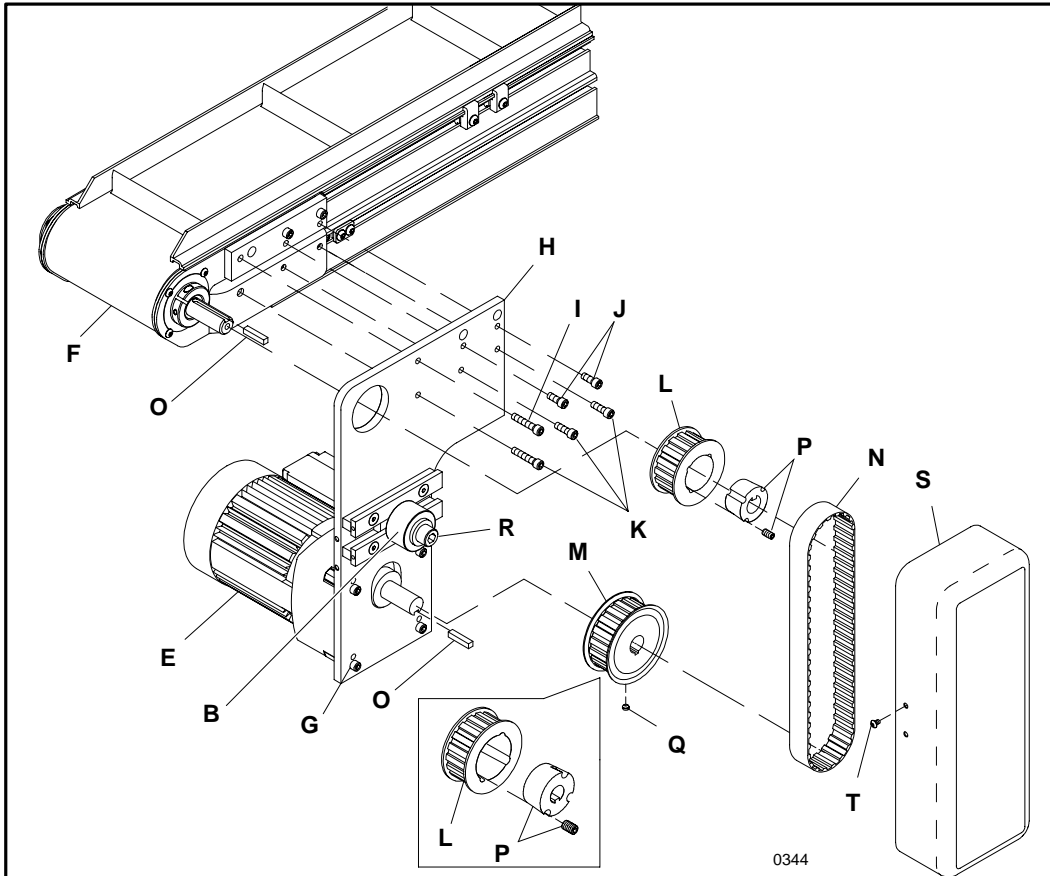

Figure 11: Bottom Drive Component Assembly Detail

Top Mount Installation & Initial Timing Belt Tension Adjustment

This mounting package can be setup in either one of two positions (A or D of Figure 12).

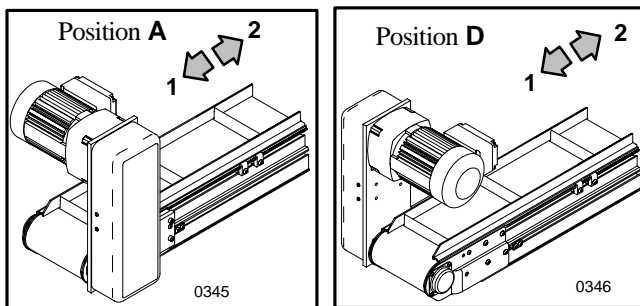

Figure 12: Top Drive Mounting Detail

The conveyor belt can be driven in either one of two directions (1 or 2 of Figure 12). Arrows show belt travel direction.

	WARNING	
Belt travel direction must correspond to arrow decals located on transition sections to prevent the creation of pinch points which could cause serious personal injury.		

1. Refer to Figure 14 and attach the gearmotor (E) and the motor mounting plate (H) to the conveyor (F) using one M6 x 30 mm socket head cap screw (I) in the top mounting hole of the mounting plate, two M6 x 16 socket head cap screws (J) in middle holes and three M6 x 20 mm socket head cap screws (K) in bottom holes.

Installation Instructions

NOTE:

The upper set (of 4) gearmotor mounting plate holes (G of of Figure 14) is only used when both gearmotor and conveyor shafts will have 16 tooth pulleys mounted to them. All other pulley combinations, use the lower set of mounting plate holes.

- Assemble the drive and driven pulleys (M and/or L) and timing belt (N). Place a square key (O) into the keyway on the gearmotor and conveyor shafts. Install the pulleys so that the timing belt is centered on the belt tensioning roller assembly and the pulleys are in line with each other. Tighten the pulley set screws (P) or Taper Lock® bushing screws (Q), which fasten the pulleys to the shafts. Determine which direction the conveyor belt is traveling and position the tensioning roller assembly on the slack side of the timing belt (Figure 13).
- Adjust timing belt tension by loosening the M12 x 25 mm socket head cap screw (R of Figure 14) and sliding the belt tensioning roller assembly against the belt. Tension should be measured at mid-point (C of Figure 13) of on the tension side of the timing belt. As a starting point for the tensioning process, there should be a 1/8" (3 mm) deflection with 6 lb (3kg or 26 N) of force.

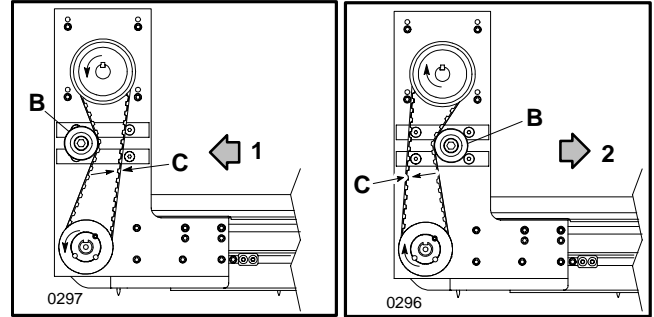

Figure 13: Top Drive Timing Belt Adjustment Detail

- Every timing belt application exhibits its own individual operating characteristics. The optimum timing belt tension should be determined experimentally. If necessary, continue to slide the tensioning roller assembly against the timing belt until the belt is tensioned so as to prevent jumping of teeth under the most severe conditions which the drive will encounter. Tighten the M12 x 25 mm socket head cap screw after tension requirements are achieved.

IMPORTANT:

Do not over tension the timing belt. Over tensioning may cause reduced belt life or bearing and drive damage.

- Attach the top drive cover (S of Figure 14) using four M4 x 10 mm button head cap screws (T).

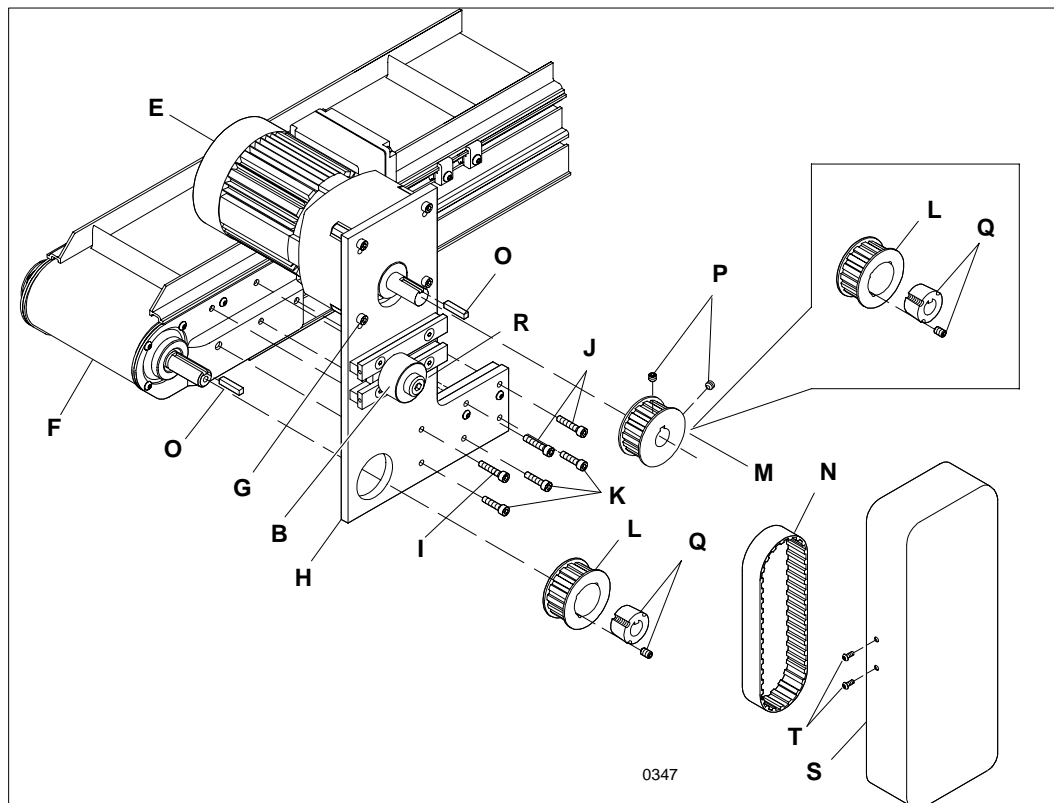

Figure 14: Top Drive Component Assembly Detail

Installation Instructions

Side Mount Installation

This mounting package can be set up in either one of two positions (**A** or **D** of Figure 15).

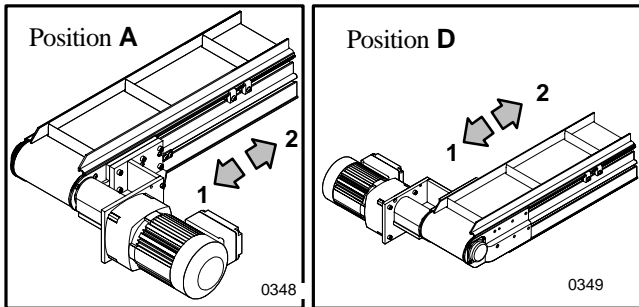



Figure 15: Side Drive Mounting Detail

In addition, the conveyor belt can be driven in either one of two directions (**1** or **2** of Figure 15). Arrows show belt travel direction.

**WARNING**

Belt travel direction must correspond to arrow decals located on transition sections to prevent the creation of pinch points which could cause serious personal injury.

Loose components shipped with the mounting kit include the square key (**K** of Figure 16), M6 x 20 mm, M6 x 25 mm and

M6 x 35 mm socket head cap screws (**L, M & N**), side drive guard (**O**) and M5 x 10 mm button head cap screws (**P**).

1. Secure the gearmotor (**J**) and the mounting plate assembly to the conveyor (**I**) using one M6 x 35 mm socket head cap screw in top mounting hole, two M6 x 20 mm socket head cap screws in lower holes and three M6 x 25 mm socket head cap screws in the bottom holes.
2. The flex coupling (**V**) is shipped attached to the gearmotor shaft (**F**). Make sure the set screw (**H**) on the end farthest from the gearmotor is loosened far enough to allow the coupling to slide onto the outboard shaft (**E**) on the conveyor.
3. Mount the assembly to the conveyor by placing the square key (**K**) into the keyway on the outboard shaft and sliding the flex coupling onto the shaft as far as the key will allow.
4. While holding the gearmotor and flex coupling assembly in alignment, secure the gearmotor to the mounting plate using the four M6 x 20 mm head cap screws.

NOTE:

Flex coupling is provided to compensate for maximum shaft misalignments (**G**) of up to 1/16" (1.5 mm).

5. Tighten the set screws on the flex coupling and re-assemble the side drive guard (**O**) to the mounting plate using the M5 x 10 mm button head cap screws (**P**).

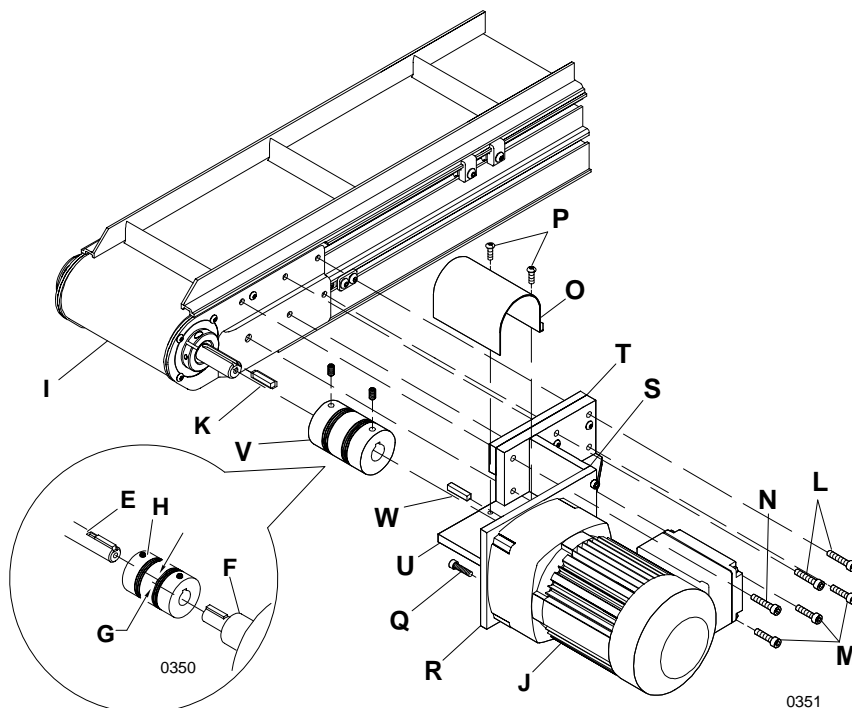

Figure 16: Side Drive Component Assembly Detail

Installation Instructions

Horizontal Infeed Chutes & Backstop

Standard Cleated and Sidewall Cleated Chute Assemblies

If not already installed, proceed to assemble and attach the components of the infeed chute in the following manner:

NOTE:

Chute sides, for both the standard cleated belt conveyors and sidewall cleated conveyors are shipped from the factory with their support brackets and mounting hardware pre-assembled. Before proceeding, remove and retain the T-bars and their mounting screws. In addition, although the drawing shows the standard cleated belt components, understand that sidewall cleated components are very similar except for some additional wiper guide and guide clamp parts attached to the bottoms of both side guides (see parts list and exploded-view on page 44).

1. Refer to drawing and install the (2 each) drop-in T-bars (A of Figures 17 & 19) into both the upper and lower conveyor T-slots, on both sides of the conveyor. Insert each T-bar by rolling it into position (A of Figure 17).

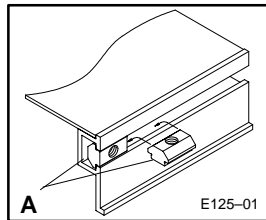

Figure 17: Drop-in T-bar Installation Detail

2. Attach the chute support plates (C of Figure 19) of each chute side to the T-bars in both the upper and lower

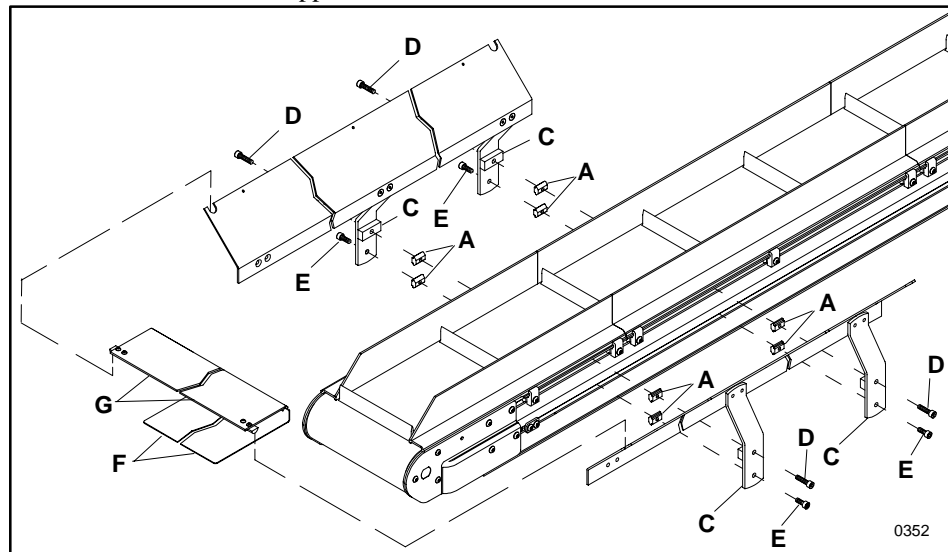
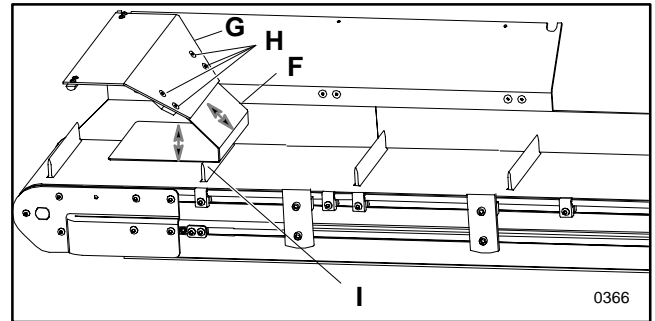

Figure 19: Chute Assembly Installation Detail

T-slots on the conveyor using M6 x 25 mm socket head cap screws (D) with the top T-bars and the M6 x 16 mm socket head cap screws (E) with the bottom T-bars. Be sure both chute sides are correctly aligned before tightly securing the attaching hardware.

Backstop Assembly

3. Properly position and install the cleat cover guide (F of Figures 17 & 18) and chute back guide (G) assembly into the aligning slots of both chute side.
4. Refer to the drawing adjust the cleat cover guide which is clamped in the chute back guide (G) so that it clears the top of each cleat (I of Figure 18). As necessary, loosen clamping screws (H) and reposition cleat cover guide (F), to obtain desired clearance. Tightly secure the clamping hardware, after desired backstop position is established.



**Figure 18: Backstop Adjustment Detail
(Front portion of Chute and its Supports removed for clarity)**

NOTE:

By design, adjustable backstop will separate (break-away) from chute sides if an obstruction or oversized object contacts it.

Start-up & Preliminary Adjustments

IMPORTANT:

The cleated conveyor belt is the single most important component of an LPZ conveyor. Therefore, Dorner recommends that both correct conveyor belt tension and proper belt tracking be correctly established before the conveyor is put into operation. Conveyor belt tensioning and tracking is not difficult, especially with the patented Dorner "rack and pinion" tensioning system and cam tracking mechanism.

Conveyor Belt Tension

The following procedure is used to tension the conveyor belt. The conveyor uses a rack and pinion assembly (G of Figure 20) to take up conveyor belt slack and achieve proper conveyor belt operating tension. To adjust the belt tension:

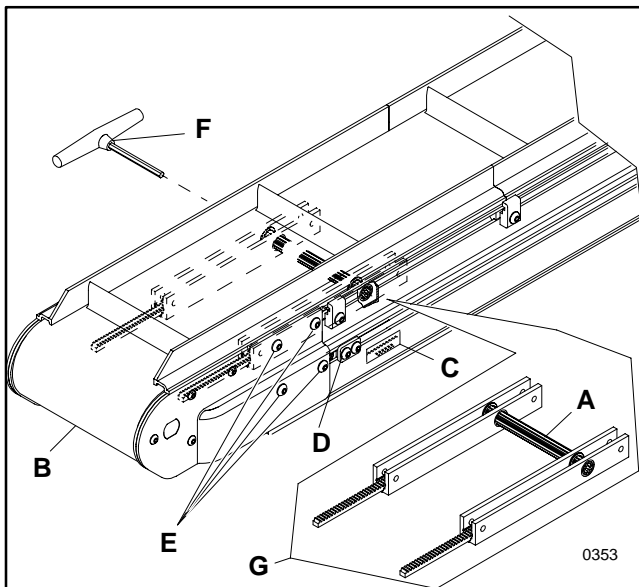

Figure 20

1. Locate the tension end (B) of the conveyor, identified with a label (C).
2. If engaged, loosen and slide belt tracking cam assemblies (D) towards the center of the conveyor on both sides of the tension end.
3. Loosen tail cover plate clamping screws (E) on both sides of the tension end.
4. Insert a 5 mm hex key wrench (F) into either end of the pinion (A).

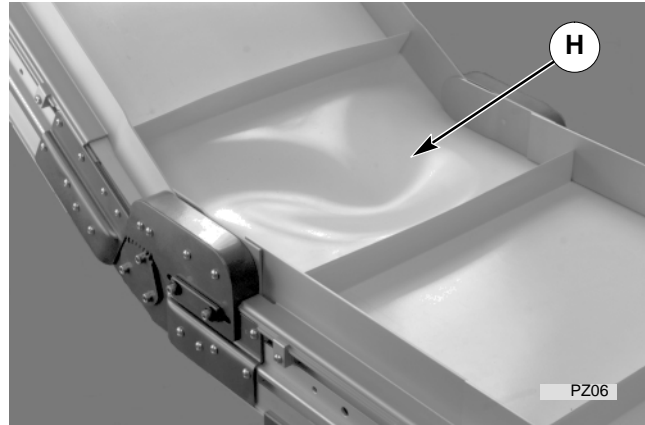

Figure 21: Conveyor Belt Buckling Caused by Over-tensioning

DO NOT ATTEMPT TO RUN CONVEYOR WHEN THIS CONDITION EXISTS!

5. Rotate the pinion to extend the tensioning end, and apply a sufficient tension to eliminate drive pulley slippage. But, do not apply too much tension to cause the conveyor belt to bow or buckle (H of Figure 21) or otherwise to pop-out from under the guide rollers on either side of the conveyor, in the area of the transition modules.

NOTE:

Refer to the table provided for maximum recommended tension pinion torque values and maximum conveyor loads for different angles. Choose the appropriate value which relates to your particular requirements.

Transition Angle	Standard Cleated Belt				Sidewall Cleated Belt			
	Tension Pinion Torque		Maximum Conveyor Load		Tension Pinion Torque		Maximum Conveyor Load	
	in-lb	Nm	lb	kg	in-lb	Nm	lb	kg
25° *	25	2.8	25	11.3	50	5.6	75	34
30° *	35	3.9	50	22.7	60	6.8	100	45.4
35°	50	5.6	75	34	70	7.9	100	45.4
40°	75	8.5	100	45.4	80	9.0	100	45.4
45°	75	8.5	100	45.4	80	9.0	100	45.4
50°	75	8.5	100	45.4	80	9.0	100	45.4
55°	75	8.5	100	45.4	80	9.0	100	45.4
60°	75	8.5	100	45.4	80	9.0	100	45.4

* Not available on 18" & 24" (457 & 610 mm) width conveyors

6. While holding the pinion in the tensioned position, tighten cover plate screws on both sides of the conveyor. Torque the mounting screws to approximately 18 in-lb (2 Nm).
7. **On Standard Cleated belt conveyors only**, the guiding must be in place before proceeding to adjust the tracking.

Start-up & Preliminary Adjustments

Conveyor Belt Tracking Adjustment Procedure

! **WARNING** !

Although all potentially hazardous areas of the Cleated Belt conveyors are shielded by bolt-on guards and there are no exposed pinch-point, the cleats themselves may create unforeseen catch points, especially when loose-fitting clothing is being worn. Exercise appropriate caution everywhere around the cleated belt.

IMPORTANT:

To avoid permanent damage to the conveyor belt during initial tracking adjustment, conveyor must only be jogged (started and stopped), instead of run continuously, until the following initial setting is established.

Make sure the belt is properly tensioned and that the conveyor is straight and level in all directions within the confines of the conveyor.

This conveyor is equipped with an articular linkage which allows the pulley to be positioned at a slight angle to facilitate belt tracking.

Check both ends of the conveyor for proper belt tracking. The belt should track centered between the tail plates on both ends of the conveyor. Conveyor belt tracking should always be adjusted on the discharge end of conveyor first. Then, check the tracking on the opposite (infeed) end of the conveyor and readjust, if necessary.

To adjust belt tracking:

1. Loosen (but do not remove) the two cam clamping plate screws (I of Figure 22) on both sides of the conveyor discharge.
2. Slide both belt tracking cam assemblies (D) as far as they can be moved toward the end of the conveyor.
3. The belt tracking cam (K) must be set to the low point at the point of contact as illustrated. The slot (L), in the

belt tracking cam should be horizontal and pointing towards the end of the conveyor.

4. Tighten the two (2) belt tracking cam retaining plate screws (I), on both sides of the conveyor.
5. **Only loosen the four tail cover plate screws (E) on the side of the conveyor that the belt is tracking toward.**
6. Use the 5 mm key wrench (F of Figure 20) to slowly rotate the belt tracking cam (K of Figure 22) in small increments in either direction to cause the belt to track away from the conveyor side, until the belt tracks in the center of the conveyor. Always allow the conveyor belt to make several revolutions between adjustments.

IMPORTANT:

Rotate belt tracking cam very slowly and in small increments, to prevent the belt from moving beyond the desired centered position.

7. While holding the belt tracking cam (K of Figure 22) in position, tighten the tail cover plate clamp screws (E) and re-check the belt tracking.
8. Recheck belt tracking, on opposite end of the conveyor, and adjust if needed.

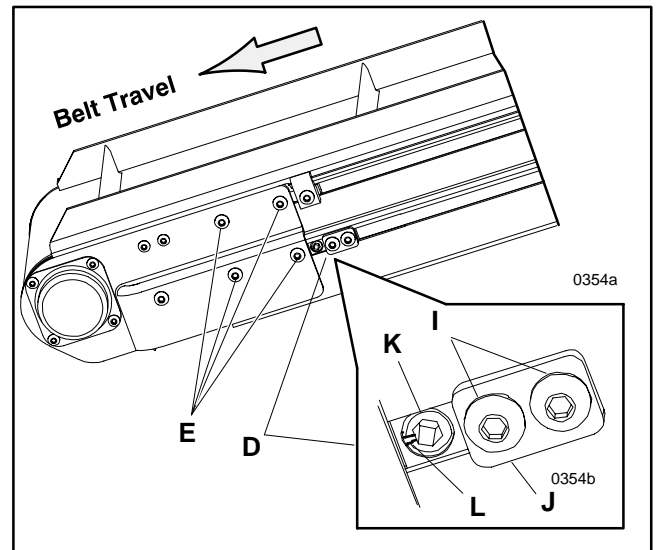

Figure 22

Maintenance - Conveyor Belt

Inspection

Inspect the conveyor belt for:

- Surface cuts or wear
- Tracking problems
- Worn edges
- Stalling or slipping
- Stretching or breaking
- Belts that walk to one side
- Non-uniform movement of the conveyor belt
- Rough edges on belt

Problem Identification

Belts that walk to one side indicate:

- Belt tracking incorrectly. Refer to “Conveyor Belt Tracking Adjustment” on page 15.
- Twisted or damaged conveyor frame
- Dirt accumulating on the outside diameter of the pulleys.

Non-uniform movement indicates:

- Excessive load on conveyor belt.

- Intermittent jam or drive train problems.
When a problem is identified, perform corrective maintenance on the conveyor.
- Conveyor or drive timing belt is not properly tensioned.

Rough edges on belt could indicate:

- Belt tracking incorrectly. Refer to “Conveyor Belt Tracking Adjustment” on page 15.
- Foreign material inside the conveyor

NOTE:

Refer to Troubleshooting Guide on page 21.

Cleaning

IMPORTANT:

Do not use belt cleaners that contain alcohol, acetone, Methyl Ethyl Ketone (MEK) or other harsh chemicals.

Use Dornier Belt Cleaner, part number 625619, or equivalent. Mild soap and water may also be used. Do not soak the belt.

Conveyor Belt Replacement & Adjustmen

Conveyor Preparations

! **WARNING** !

To prevent injury, make sure all electrical power has been disconnected before you perform any maintenance, make any adjustments or replace any components. In addition, the weight of the gearmotor is all on one end of the conveyor. This could cause the conveyor and stand to tip over when the anchor components are removed. There should be some form of extra support (O of Figure 29) for the gearmotor while the conveyor belt is being changed.

1. Disconnect all electrical power sources.
2. To facilitate re-assembly, mark any critical locations for accessory attachments along the entire side of the conveyor frame from which the belt is going to be removed.
3. Wherever possible, conveyor belt should always be removed from the side opposite the gearmotor, controls, stops or other attached accessories which could interfere with belt removal.

Standard Cleated Belt Conveyor Guiding

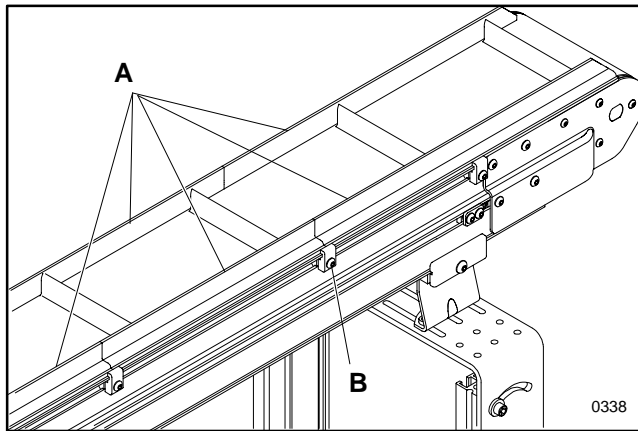

Figure 23: Standard Cleated Belt Conveyor Guiding Removal Detail

NOTE:

Several guiding configurations are provided for the Standard Cleated belt conveyors with respect to the length of the conveyor section, the type of transition module and the direction of belt travel. See parts illustrations beginning on page 35.

The LPZ Standard Cleated belt conveyor is provided with guiding (A of Figure 23) on both sides of each section. When the conveyor belt is going to be replaced, the guiding must be temporarily removed from the side opposite the gearmotor, so that the existing conveyor belt can be removed from that section and the new belt installed.

Be sure to mark (or make appropriate notations) of the anchor clamp positions and guide section locations. Then, remove guiding from the side of the conveyor opposite the gearmotor.

To remove the guiding, refer to Figure 23 and loosen, remove and retain the guide clamps (B). Guide replacement is in reverse sequence of removal.

Releasing Conveyor Belt Tension

The following procedure should be used to release the conveyor belt tension, before proceeding to remove the old belt. These same procedures apply to both Standard Cleated belt and Sidewall Cleated belt conveyors.

1. **On a Standard Cleated belt conveyor only**, remove and retain the tail guide sections (C of Figure 24), by loosening, removing and retaining the guide clamps (B), on both sides of the conveyor.
2. If engaged, loosen the belt tracking cam assemblies (D), on both sides of the tensioning end (E), identified by label (F). Then, slide the cam assemblies toward the middle of the conveyor.
3. Loosen the tail cover plate screws (G), on both sides of the tensioning end.
4. Collapse the tensioning end (E) of the conveyor by pushing it back into the conveyor frame, using the heel of your hand. This will sufficiently loosen the belt for removal.

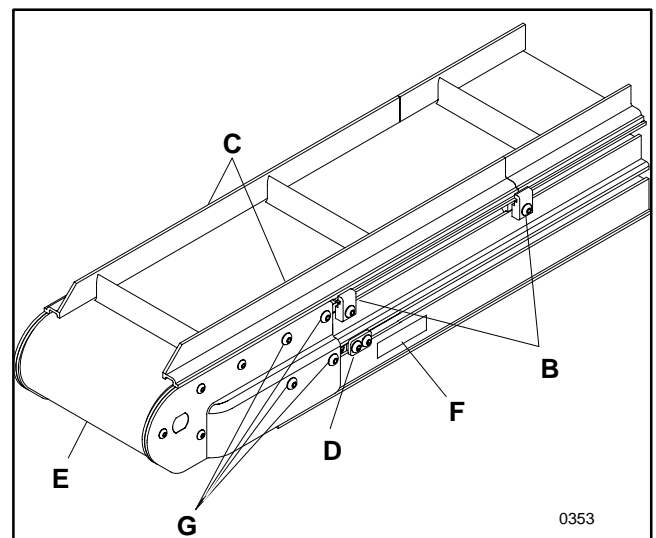

Figure 24

Conveyor Belt Replacement & Adjustments

Conveyor Belt Guide Rollers

LPZ cleated belt conveyors are provided with conveyor belt guide roller assemblies on all nose-over and horizontal to incline transition assemblies. When shipped, all guide rollers assemblies are attached to their respective sections.

The conveyor belt guide roller assemblies must be temporarily removed from the side opposite the gearmotor, so that the existing conveyor belt can be removed from that section and the new belt installed.

Guide Roller Assembly for Nose-over Transitions

Refer to and temporarily detach the guide roller assembly, in the following manner:

1. Remove and retain the two (2) guard mounting M5 x 10 mm button head cap screws (A of Figure 25) and detach the guard (B).
2. Remove and retain the two (2) roller assembly mounting M6 x 12 mm button head cap screws (C) and detach the roller assembly (D).
3. With the guard and roller removed, the area is unobstructed so that the conveyor belt can be slid into position.
4. After the conveyor belt is installed, the roller and guard can be replaced by reversing the removal steps.

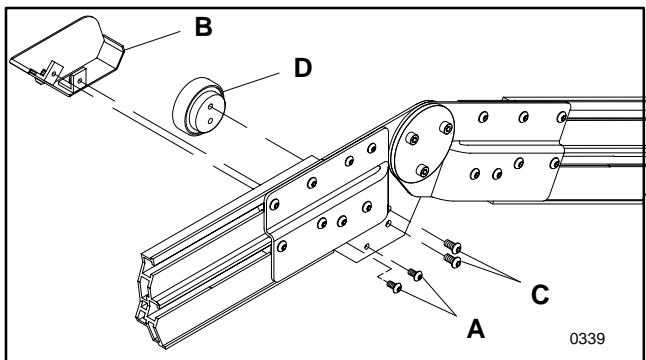

Figure 25: Nose-over Transition Guide Roller Assembly Removal Detail

Guide Roller Assembly for Horizontal to Incline Transitions

Refer to the following drawing and temporarily detach the guide roller assembly, in the following manner:

NOTE:

The horizontal to incline guide roller assemblies for the Standard Cleated belt unit and for the Sidewall Cleated unit look similar and function alike. The primary difference, between components, is in respect to accommodating the guiding which is only present on the Standard Cleated belt unit.

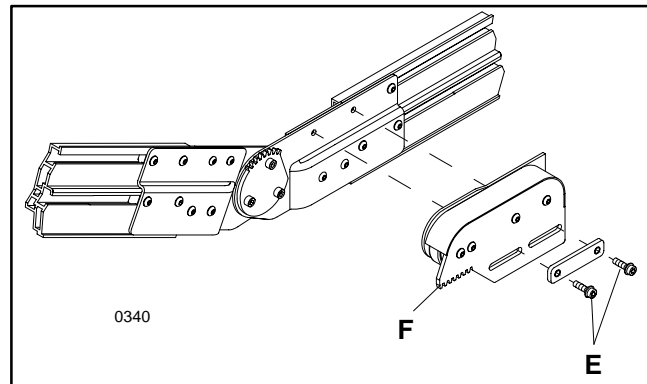

Figure 26: Horizontal to Incline Transition Guide Roller Assembly Removal Detail

1. Remove and retain the two (2) M6 x 20 mm socket head cap screws (E of Figure 26) from the top roller slide plate.
2. With the two M6 screws removed, the slide plate and top roller assembly (F) can be removed.
3. With the slide plate and top roller assembly removed, the area is unobstructed so that the conveyor belt can be slid into position.
4. After the conveyor belt is installed, the slide plate and top roller can be replaced in the following manner:
 - a. Refer to Figure 27 and properly align the teeth of the slide plate rack with the aligning pockets of the pivot gear. When properly aligned, the endmost tooth (G) of the slide plate rack (H) will engage the first pocket (I) of the pivot gear (J), as shown
 - b. After proper and correct alignment is obtained, bring the roller into contact with the top of the conveyor belt and align the slide plate mounting holes.
 - c. Replace and re-secure the two (2) M6 x 20 mm socket head cap screws (E of Figure 26).

Conveyor Belt Replacement & Adjustmen

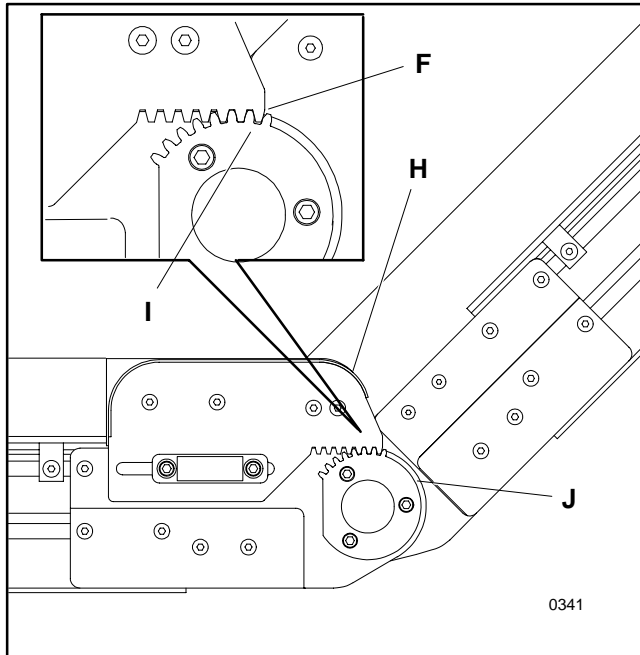

Figure 27: Typical Standard Cleated Belt Conveyor Horizontal to Incline Transition Guide Roller Detail

Conveyor Belt Removal

NOTE:

Because conveyor belt removal and replacement involves temporarily disconnecting a section from a stand, it is recommended that the new conveyor belt be replaced on each section right after the old belt is removed. Always perform conveyor belt removal and replacement “one section at a time” to prevent twisting the conveyor frame or imposing undue stress on any of the stand attachment points.

NOTE:

For additional details, refer to separate Metric Support Stands & Conveyor Mountings Parts, Assembly & Maintenance Manual. As necessary, properly support the gearmotor end, when loosening and removing the stand attachment components.

For Conveyor with Fully Adjustable Aluminum Support Stands

1. Referring to Figure 28, safely and temporarily support the conveyor section with a sturdy support mechanism (K) (such as wooden blocks or a sawhorse).

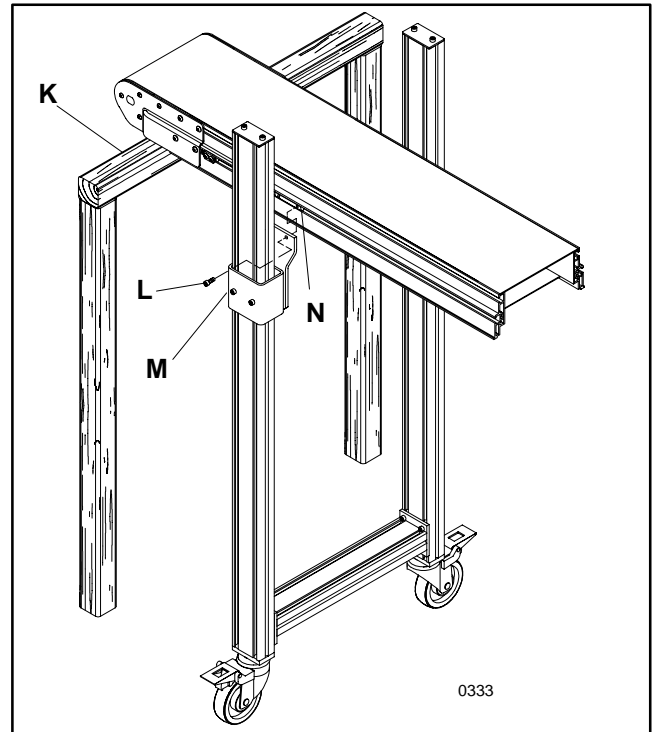



Figure 28

2. Temporarily disconnect the adjustable stand by removing the two (2) screws (L) which attach each adjustable stand sleeve assembly (M) to a T-bar (N) in the T-slot on each side of the conveyor.

For Conveyors with Aluminum or Steel Support Stand



WARNING



To prevent injury from the support stand tipping-over when the conveyor is uncoupled, be sure to anchor the stand to the floor or otherwise properly stabilize the stand before it is detached from the conveyor.

1. Referring to Figure 29, safely and temporarily support the conveyor section with a sturdy support mechanism (O) (such as wooden blocks or a sawhorse).
2. Remove and retain the mounting clamp plate screw and clamp plate (P of Figure 29) from the conveyor.
3. Detach and retain the mounting clamp bracket (Q) from the top plate (R) on the side opposite the gearmotor.

Conveyor Belt Replacement & Adjustments

For All Conveyors

1. Slide the old belt sideways and away from the conveyor section (Figure 30).
2. Install the new conveyor belt on this section, following the information under the next topic, and replace the stand attaching hardware.
3. Continue to remove the old belt and install the new belt on each conveyor section until the new belt is fully installed.

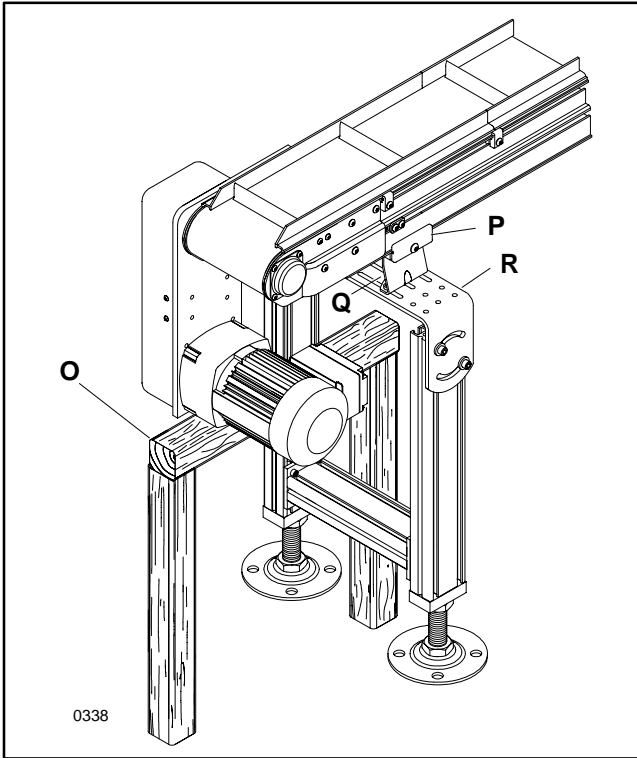

Figure 29

Conveyor Belt Replacement

1. Install the new belt by sliding it sideways onto the conveyor frame opposite from the way the old belt was removed.

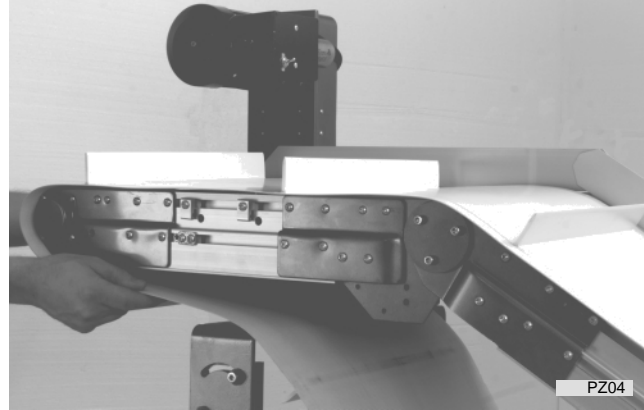

Figure 30: LPZ Conveyor Belt Being Slid Off Conveyor Through Gap Created By Removing Aluminum or Steel Stand Attachment Components

2. Reverse the appropriate steps which were followed when removing original belt.

NOTE:

On standard cleated belt conveyors, do not replace the guiding, at this time. Replace the guiding after proper conveyor belt tension has been achieved.

3. Make sure all hardware, that was either removed or loosened, is replaced and properly tightened. Do not, tightly secure the tail cover plate screws, at this time.
4. Refer to Conveyor Belt Tension Adjustment information in the Start-up & Preliminary Adjustments section on page 14.
5. Refer to Conveyor Belt Tracking information in the Start-up & Preliminary Adjustments section on page 15.
6. After the proper belt tension and tracking is established, replace the controls, stops and other attached accessories referring to the positions previously marked.

Troubleshooting Guide

Gearmotors

Problem	Possible Cause	Solution
Motor cuts out intermittently.	Overloading.	Check conveyor load. Use torque wrench to determine input torque. Check for guides or accessories rubbing on belt. Check belt tracking.
	Improper cooling.	Check motor operation and ambient temperature.
Motor running hot. (above 170°F).	Overloading.	Check amp draw, replace motor, reduce conveyor load.
	Jammed part.	Remove jam.
	Incorrect voltage/wiring.	Check wiring diagram. Replace motor or change wiring.
	Improper cooling.	Reduce excessive ambient temperature.
Conveyor runs in wrong direction.	Improper wiring.	Check wiring diagram.
Oil leaking from Gearbox.	Broken or damaged seal.	Contact manufacturer for replacement parts or Dorner for further instructions.

	WARNING	
Remove power before attempting to rewire motor or system electrical control.		

Timing Belt

Problem	Possible Cause	Solution
Intermittent conveyor belt travel.	Timing belt is too loose.	Adjust timing belt tension. Refer to “Bottom Mount Installation & Initial Timing Belt Tension Adjustment” topic on page 9 or “Top Mount Installation & Initial Timing Belt Tension Adjustment” topic on page 10.
	Worn or damaged timing (drive) belt.	Replace defective timing belt.

Conveyor Belt

Problem	Possible Cause	Solution
Belt slipping.	Belt is too loose.	Adjust belt tension. Refer to “Conveyor Belt Tension” topic on page 14. If belt is still loose, replace belt. Note: Belt may have stretched. See “Belt Stretching” Problem below.
	Dirt impacted in knurl on end of driven pulley.	Clean pulley.
	Knurl worn on pulley.	Replace pulley.
	Excessive weight on conveyor. Note: May be a combination of this and drive is pushing conveyor belt.	Reduce weight on conveyor by reducing production rate, or increasing belt speed.
	Drive is “pushing” belt. Note: May be a combination of this and excessive weight on conveyor.	Move drive to discharge end of conveyor.
	Part size is too small for Standard Cleated belt.	Convert to Sidewall Cleated belt conveyor.
	Debris wedged in belt path or in conveyor.	Clean conveyor and install horizontal chute.

Troubleshooting Guide

Conveyor Belt (continued)

Problem	Possible Cause	Solution
Belt stretching.	Solvent or chemical reaction with belt.	Remove solvent. Test solvent with belt sample.
	Belt repeatedly stalled, causing pulley to wear or "burn" in to backside of belt.	Replace belt and identify reason for stalling.
Cuts on belt surface.	Sharp parts penetrating belt surface.	Install baffle to reduce energy of falling part.
	Guides or accessories rubbing on belt.	Adjust as necessary.
Worn belt edges.	Debris impacted on pulleys can cause belt tracking problems.	Clean pulleys. Correct source of contamination. See Belt Tracking Incorrectly below.
	Belt tracking incorrectly.	Refer to "Conveyor Belt Tracking Adjustment Procedure" topic on page 15.
Belt breaking at splice.	Solvent or chemical reaction with belt.	Remove solvent. Test solvent with belt sample.
Belt tracking incorrectly.	Pulleys not perpendicular to conveyor center line.	Inspect and reposition pulleys, if necessary.
	Frame misalignment. Note: Frame mounting surface may be misaligned.	Frame mounting must be straight and within the same plane. Check with a straight edge and level.
	Frame distortion due to damage.	Repair or replace frame components and/or bed plate. Check with a straight edge.
	Top guide roller gear rack not in correct position.	Re-adjust guide roller per details under "Conveyor Belt Guide Rollers" topic on page 18.
	Belt tracking cam incorrectly adjusted.	Refer to "Conveyor Belt Tracking Adjustment Procedure" topic on page 15.
Belt bulging or popping-out at guide rollers.	Belt over-tensioned.	Re-adjust belt tension. Refer to "Conveyor Belt Tension" topic on page 14.
	Excessive weight on conveyor.	Reduce weight on conveyor by reducing production rate, or increasing belt speed.
Belt slipping.	Elevation angle too small for load.	Increase elevation angle and readjust belt tension and tracking, as required.

Standard Load Intermediate Assemblies

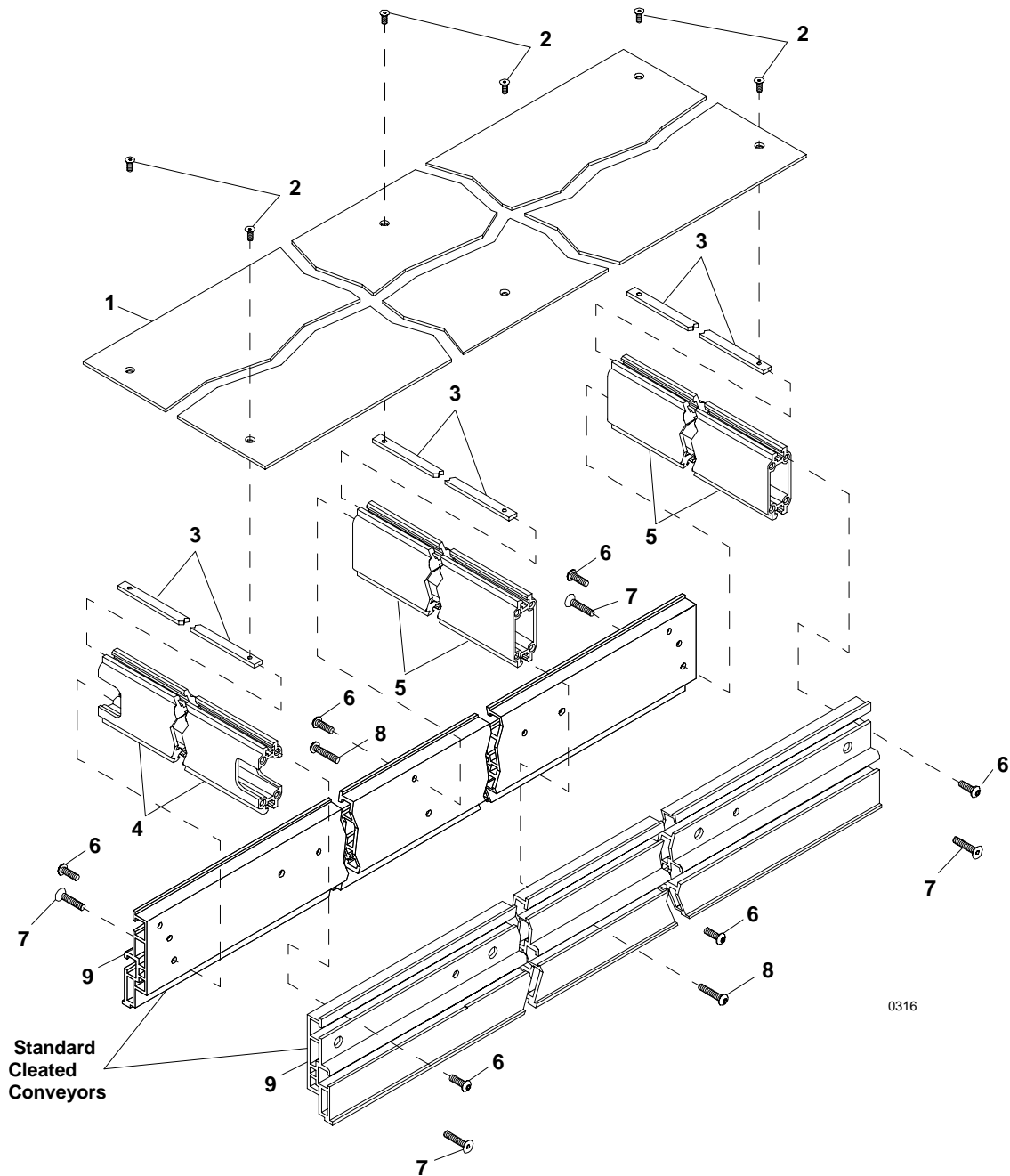

0316

Item	Part No.	Part Description
1	See Chart	Bedplate
2	300353MP	Bedplate Screw, M4-0.70 x 10 mm
3	See Chart	Rail Nut Strip
4	See Chart	Center Rail, Tension End
5	See Chart	Center Rail
6	910516M	Button Head Cap Screw, M5-0.80 x 16 mm
7	930525M	Flat Head Cap Screw, M5-0.80 x 25 mm
8	910525M	Button Head Cap Screw, M5-0.80 x 25 mm
9	See Chart	Side Rail, Non-tension End, (Standard Cld.)
10	See Chart	Side Rail, Non-tension End, (Sidewall Cld.)
11	307201	Spacer, Nut Strip (see page 24)

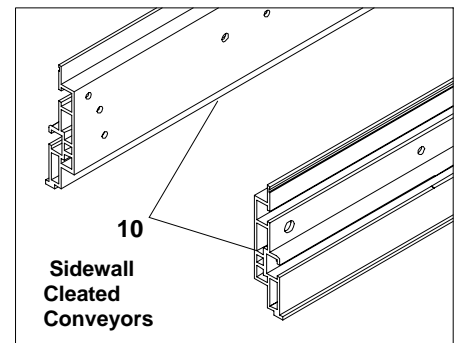

NOTE:

Intermediate sections are available in standard nominal lengths and widths as shown below. The 18" (457 mm) bedplate uses a combination of a 10" (254 mm) and an 8" (203 mm) bedplate (laid side by side) and, the 24" (610 mm) bedplate uses a combination of two 12" (305 mm) bedplates (laid side by side). Each pair of nut strips, used to secure the bedplates, are separated by a nut strip spacer (11).

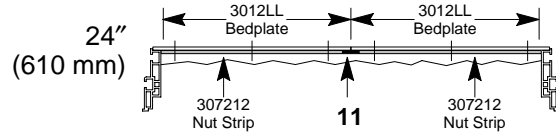
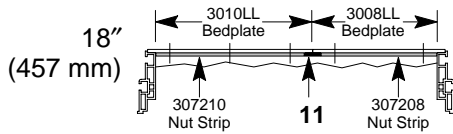

Bedplate

Item 1

Width in " (mm)	Length in ft (mm)										
	2 (610)	3 (915)	4 (1220)	5 (1525)	6 (1830)	7 (2135)	8 (2440)	9 (2745)	10 (2050)	11 (3355)	12 (3660)
8 (203)	300802P	300803P	300804P	300805P	300806P	300807P	300808P	300809P	300810P	300811P	300812P
10 (254)	301002P	301003P	301004P	301005P	301006P	301007P	301008P	301009P	301010P	301011P	301012P
12 (305)	301202P	301203P	301204P	301205P	301206P	301207P	301208P	301209P	301210P	301211P	301212P
18 (457)	300802P	300803P	300804P	300805P	300806P	300807P	300808P	300809P	300810P	300811P	300812P
	& 301002P	& 301003P	& 301004P	& 301005P	& 301006P	& 301007P	& 301008P	& 301009P	& 301010P	& 301011P	& 301012P
24 (610)	301202P	301203P	301204P	301205P	301206P	301207P	301208P	301209P	301210P	301211P	301212P
	& 301202P	& 301203P	& 301204P	& 301205P	& 301206P	& 301207P	& 301208P	& 301209P	& 301210P	& 301211P	& 301212P

Rail Nut Strip

Item 3

Width	Part No.
8" (203 mm)	307208M
12" (305 mm)	307212M
18" (457 mm)	307208 M & 307210M
24" (610 mm)	307212M & 307212M

Center Rail, Tension End

Item 4

Width	Part No.
8" (203 mm)	303308M
12" (305 mm)	303312M
18" (457 mm)	303318M
24" (610 mm)	303324M

Center Rail

Item 5

Width	Part No.
8" (203 mm)	300208M
12" (305 mm)	300212M
18" (457 mm)	300218M
24" (610 mm)	300224M

Side Rails, Low Side (Standard Cleated Conveyors)

Items 9

Length	Part No.
1 ft (305 mm)	300101
2 ft (610 mm)	300102
3 ft (915 mm)	300103
4 (1220 mm)	300104
5 (1525 mm)	300105
6 (1830 mm)	300106
7 (2135 mm)	300107
8 ft (2440 mm)	300108
9 ft (2745 mm)	300109
10 ft (2050 mm)	300110
11 ft (3355 mm)	300111
12 ft (3660 mm)	300112

Side Rails, High Side (Sidewall Cleated Conveyors)

Items 10

Length	Part No.
1 ft (305 mm)	300001
2 ft (610 mm)	300002
3 ft (915 mm)	300003
4 (1220 mm)	300004
5 (1525 mm)	300005
6 (1830 mm)	300006
7 (2135 mm)	300007
8 ft (2440 mm)	300008
9 ft (2745 mm)	300009
10 ft (2050 mm)	300010
11 ft (3355 mm)	300011
12 ft (3660 mm)	300012

Light Load Intermediate Assemblies

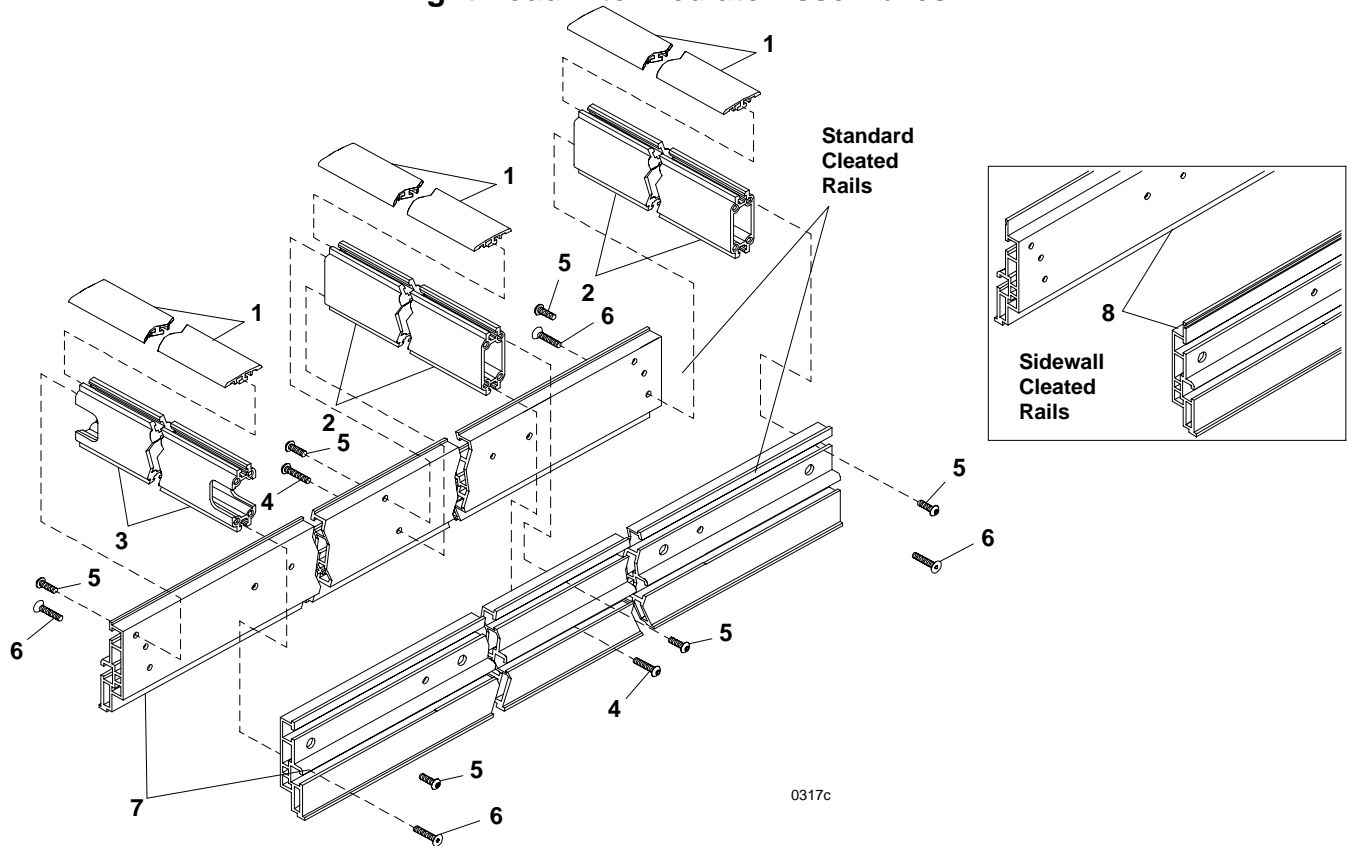

0317c

Item	Part No.	Part Description
1	300684	Belt Support Strip 8" (203 mm) Wide
	300685	Belt Support Strip 12" (305 mm) Wide
	300686	Belt Support Strip 18" (457 mm) Wide
	300687	Belt Support Strip 24" (610 mm) Wide
2	300208M	Center Rail 8" (203 mm) Wide
	300212M	Center Rail 12" (305 mm) Wide
	300218M	Center Rail 18" (457 mm) Wide
	300224M	Center Rail 24" (610 mm) Wide
3	303308M	Center Rail, Tension End 8" (203 mm) Wide
	303312M	Center Rail, Tension End 12" (305 mm) Wide
	303318M	Center Rail, Tension End 18" (457 mm) Wide
	303324M	Center Rail, Tension End 24" (610 mm) Wide
4	910525M	Button Head Cap Screw M5-0.80 x 25 mm
5	910516M	Button Head Cap Screw, M5-0.80 x 16 mm
6	930525M	Flat Head Cap Screw, M5-0.80 x 25 mm

Item	Part No.	Part Description
7	303501	Side Rail, Low Side 1 ft (305 mm) (Std. Cltd.)
	303502	Side Rail, Low Side 2 ft (610 mm) (Std. Cltd.)
	303503	Side Rail, Low Side 3 ft (915 mm) (Std. Cltd.)
	303504	Side Rail, Low Side 4 ft (1220 mm) (Std. Cltd.)
	303505	Side Rail, Low Side 5 ft (1525 mm) (Std. Cltd.)
	303506	Side Rail, Low Side 6 ft (1830 mm) (Std. Cltd.)
	303507	Side Rail, Low Side 7 ft (2135 mm) (Std. Cltd.)
	303508	Side Rail, Low Side 8 ft (2440 mm) (Std. Cltd.)
	303509	Side Rail, Low Side 9 ft (2745 mm) (Std. Cltd.)
	303510	Side Rail, Low Side 10 ft (3050 mm) (Std. Cltd.)
	303511	Side Rail, Low Side 11 ft (3355 mm) (Std. Cltd.)
	303512	Side Rail, Low Side 12 ft (3660 mm) (Std. Cltd.)
8	303601	Side Rail, High Side 1 ft (305 mm) (Sdw. Cltd.)
	303602	Side Rail, High Side 2 ft (610 mm) (Sdw. Cltd.)
	303603	Side Rail, High Side 3 ft (915 mm) (Sdw. Cltd.)
	303604	Side Rail, High Side 4 ft (1220 mm) (Sdw. Cltd.)
	303605	Side Rail, High Side 5 ft (1525 mm) (Sdw. Cltd.)
	303606	Side Rail, High Side 6 ft (1830 mm) (Sdw. Cltd.)
	303607	Side Rail, High Side 7 ft (2135 mm) (Sdw. Cltd.)

303608	Side Rail, High Side 8 ft (2440 mm) (Sdw. Cld.)
303609	Side Rail, High Side 9 ft (2745 mm) (Sdw. Cld.)
303610	Side Rail, High Side 10 ft (3050 mm) (Sdw. Cld.)
303611	Side Rail, High Side 11 ft (3355 mm) (Sdw. Cld.)
303612	Side Rail, High Side 12 ft (3660 mm) (Sdw. Cld.)

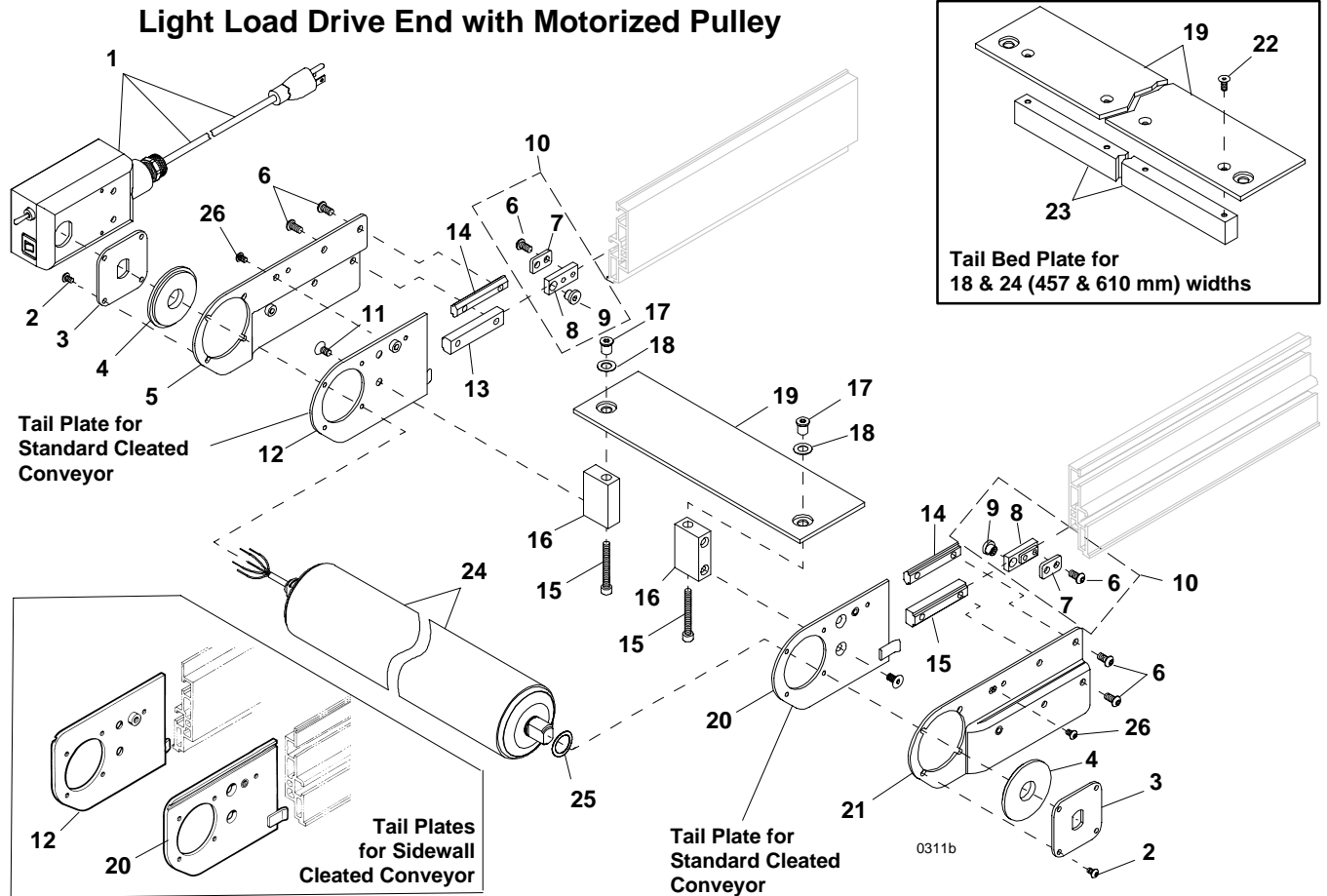

Item	Part No.	Part Description
1	300849M	Switchbox Ass'y
2	910510M	Button Head Cap Screw, M5-0.80 x 10 mm
3	300658M	Power Moller Drive Plate
4	300660M	Power Moller Spacer Disc
5	300032M	Tail Cover Plate, Right Hand, Drive End
6	910612M	Button Head Cap Screw, M6-1.0 x 12 mm
7	200038M	Cam Clamping Plate
8	200341M	Cam Retaining Block
9	200039M	Belt Tracking Cam
10	200331M	Cam Mounting Ass'y
11	930612M	Flat Head Cap Screw, M6-1.0 x 12 mm
12	300068M	Tail Plate, Right Hand, Drive End (Std. Cltd.)
	300066M	Tail Plate, Right Hand, Drive End (Sdw. Cltd.)
13	300152M	T-bar
14	300150M	Drop-In T-bar
15	920650M	Socket Head Cap Screw, M6-1.0 x 50 mm
16	300155M	Bed-Link Mounting Block
17	300158M	Threaded Bushing
18	807-384	Spring Washer
19	301312	Tail Bedplate, Non-tension End, 12" (305 mm)

301318M	Tail Bedplate, Non-tension End, 18" (457 mm)
301324M	Tail Bedplate, Non-tension End, 24" (610 mm)

Replacement Parts

LPZ Cleated Belt Conveyors

Item	Part No.	Part Description
20	300069M	Tail Plate, Left Hand, Drive End (Std. Cltd.)
	300067M	Tail Plate, Left Hand , Drive End (Sdw. Cltd.)
21	300033M	Tail Cover Plate, Left Hand, Drive End
22	930512M	Flat Head Cap Screw, M5-0.80 x 12 mm
23	303018M	Bedplate Tail Bar 18" (457 mm)
	303024M	Bedplate Tail Bar 24" (610 mm)
24	300951	20 ft/min., 115 VAC Motorized Pulley Ass'y, 3" Dia. x 12" (70 mm Dia. x 305 mm)
	300952	20 ft/min., 115 VAC Motorized Pulley Ass'y, 3" Dia. x 18" (70 mm Dia. x 457 mm)

	300953	20 ft/min., 115 VAC Motorized Pulley Ass'y, 3" Dia. x 24" (70 mm Dia. x 610 mm)
	300954	28 ft/min., 115 VAC Motorized Pulley Ass'y, 3" Dia. x 12" (70 mm Dia. x 305 mm)
	300955	28 ft/min., 115 VAC Motorized Pulley Ass'y, 3" Dia. x 18" (70 mm Dia. x 457 mm)
	300956	28 ft/min., 115 VAC Motorized Pulley Ass'y, 3" Dia. x 24" (70 mm Dia. x 610 mm)
25	807-856	Curved Disk Spring
26	910506M	Button Head Cap Screw, M5-0.80 x 6 mm

Drive End Tail Assembly

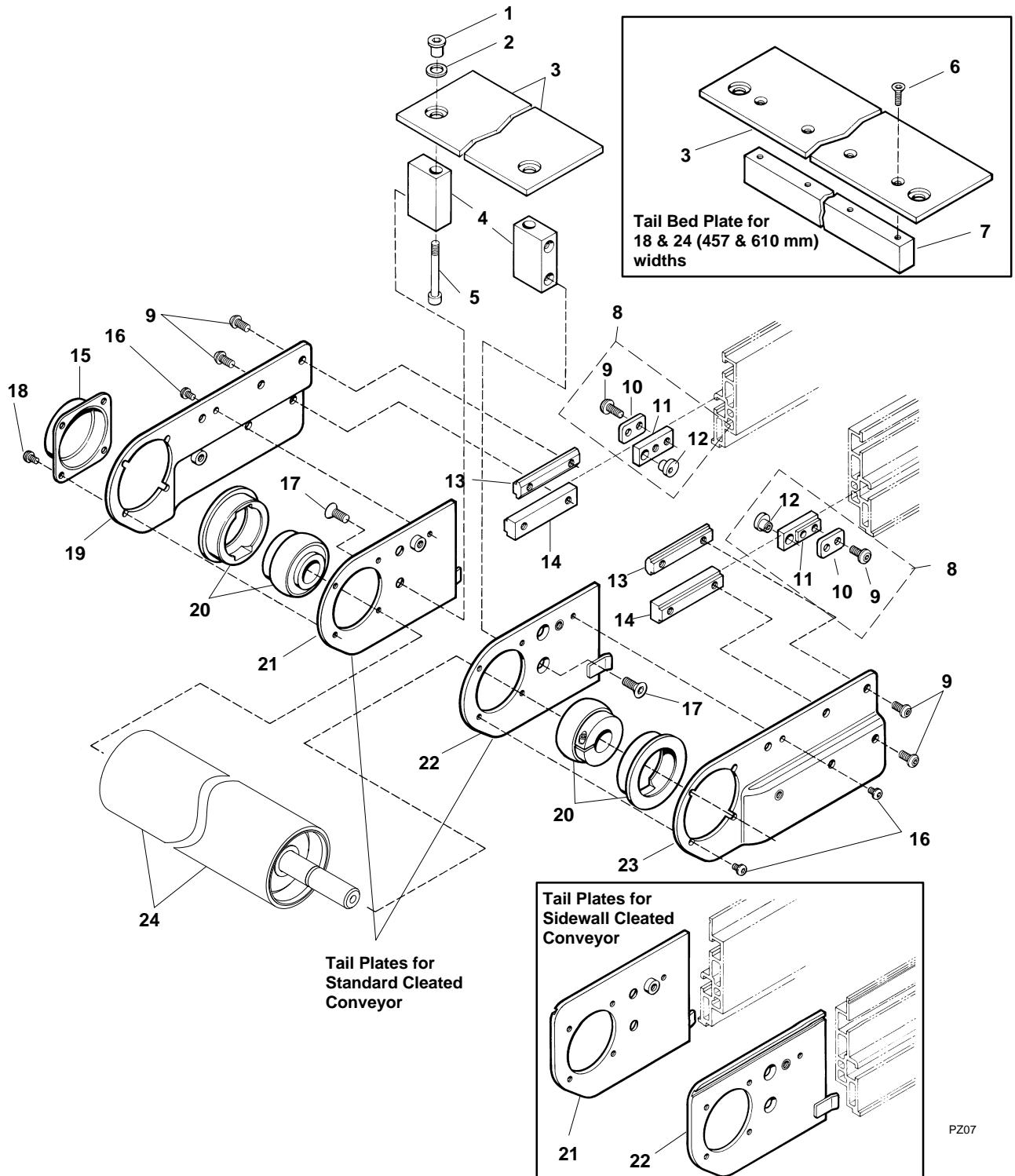

PZ07

Replacement Parts

LPZ Cleated Belt Conveyors

Item	Part No.	Part Description
1	300158M	Threaded Bushing
2	807-384	Spring Washer
3	301308	Tail Bedplate, Non-tension End, 8" (203 mm)
	301312	Tail Bedplate, Non-tension End, 12" (305 mm)
	301318M	Tail Bedplate, Non-tension End, 18" (457 mm)
	301324M	Tail Bedplate, Non-tension End, 24" (610 mm)
4	300155M	Bed-Link Mounting Block
5	920650M	Socket Head Cap Screw, M6-1.0 x 50 mm
6	930512M	Flat Head Cap Screw, M5-0.80 x 12 mm
7	303018M	Bedplate Tail Bar 18" (457 mm)
	303024M	Bedplate Tail Bar 24" (610 mm)
8	200331M	Cam Mounting Ass'y
9	910612M	Button Head Cap Screw, M6-1.0 x 12 mm
10	200038M	Cam Clamping Plate
11	200341M	Cam Retaining Block
12	200039M	Belt Tracking Cam
13	300150M	Drop-In T-bar

Item	Part No.	Part Description
14	300152M	T-bar
15	300139M	Drive Bearing Shaft Cover
16	910506M	Button Head Cap Screw, M5-0.80 x 6 mm
17	930612M	Flat Head Cap Screw, M6-1.0 x 12 mm
18	910508M	Button Head Cap Screw, M5-0.80 x 8 mm
19	300032M	Tail Cover Plate, Right Hand, Drive End
20	300146	Bearing Ass'y
21	300068M	Tail Plate, Right Hand, Drive End, Low Side (Standard Cltd.)
	300066M	Tail Plate, Right Hand, Drive End, High Side (Sidewall Cltd.)
22	300069M	Tail Plate, Left Hand, Drive End, Low Side (Standard Cltd.)
	300067M	Tail Plate, Left Hand, Drive End, High Side (Sidewall Cltd.)
23	300033M	Tail Cover Plate, Left Hand, Drive End
24	307308M	Drive Pulley 8" (203 mm) (19 mm Shaft)
	307312M	Drive Pulley 12" (305 mm) (19 mm Shaft)
	307318M	Drive Pulley 18" (457 mm) (19 mm Shaft)
	307324M	Drive Pulley 24" (610 mm) (19 mm Shaft)

Tension End Tail Assembly

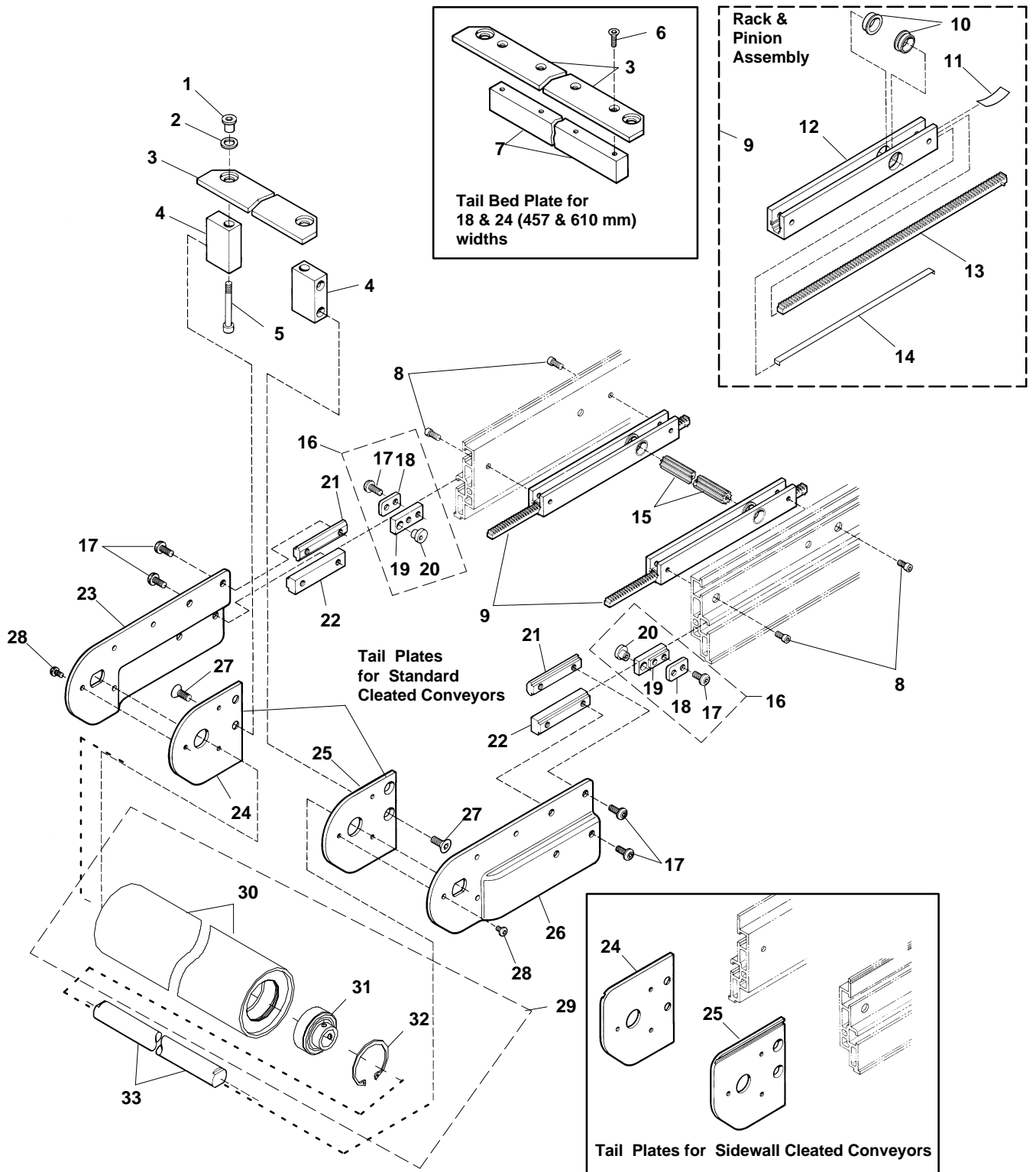

PZ08

Replacement Parts

LPZ Cleated Belt Conveyors

Item	Part No.	Part Description
1	300158M	Threaded Bushing
2	807-384	Spring Washer
3	301708	Tail Bedplate, Tension End, 8" (203 mm)
	301712	Tail Bedplate, Tension End, 12" (305 mm)
	301718M	Tail Bedplate, Tension End, 18" (457 mm)
	301724M	Tail Bedplate, Tension End, 24" (610 mm)
4	300155M	Bed-Link Mounting Block
5	920650M	Socket Head Cap Screw, M6-1.0 x 50 mm
6	930512M	Flat Head Cap Screw, M5-0.80 x 12 mm
7	303018M	Bedplate Tail Bar 18" (457 mm)
	303024M	Bedplate Tail Bar 24" (610 mm)
8	920508M	Socket Head Cap Screw, M5-0.80 x 8 mm
9	300169M	Rack and Pinion Housing Ass'y
10	200034	Pinion Wear Ring
11	200151	Back Bowed Spring
12	300166M	Take-up Rack Housing
13	300167	Rack Gear
14	300168	Wear Rack Strip
15	203008M	Pinion Gear 8" (203 mm)
	203012M	Pinion Gear 12" (305 mm)
	203018M	Pinion Gear 18" (457 mm)
	203024M	Pinion Gear 24" (610 mm)
16	200331M	Cam Mounting Ass'y
17	910612M	Button Head Cap Screw, M6-1.0 x 12 mm
18	200038M	Cam Clamping Plate
19	200341M	Cam Retaining Block
20	200039M	Belt Tracking Cam
21	300150M	Drop-In T-bar

Item	Part No.	Part Description
22	300152M	T-bar
23	300028M	Tail Cover Plate, Right Hand, 3" (70 mm)
24	300060M	Tail Plate, Right Hand, 3" (70 mm), Low Side, (Standard Cleated)
	300058M	Tail Plate, Right Hand, 3" (70 mm), High Side (Sidewall Cleated)
25	300061M	Tail Plate, Left Hand, 3" (70 mm), Low Side (Standard Cleated)
	300059M	Tail Plate, Left Hand, 3" (70 mm), High Side (Sidewall Cleated)
26	300029M	Tail Cover Plate, Left Hand, 3" (70 mm)
27	930612M	Flat Head Cap Screw, M6-1.0 x 12 mm
28	910506M	Button Head Cap Screw, M5-0.80 x 6 mm
29	306708	Idler Pulley Ass'y 8" (203 mm)
	306712	Idler Pulley Ass'y 12" (305 mm)
	306718	Idler Pulley Ass'y 18" (457 mm)
	306724	Idler Pulley Ass'y 24" (610 mm)
30	326608	Aluminum Pulley Tube, 8" (203 mm)
	326612	Aluminum Pulley Tube, 12" (305 mm)
	326618	Aluminum Pulley Tube, 18" (457 mm)
	326624	Aluminum Pulley Tube, 24" (610 mm)
31	802-110	Ball Bearing (Set Screws Removed)
32	915-051	Retaining Ring
33	301908	Idler Shaft 8" (203 mm) Wide
	301912	Idler Shaft 12" (305 mm) Wide
	301918	Idler Shaft 18" (457 mm) Wide
	301924	Idler Shaft 24" (610 mm) Wide

Nose-over Transition Module Assemblies

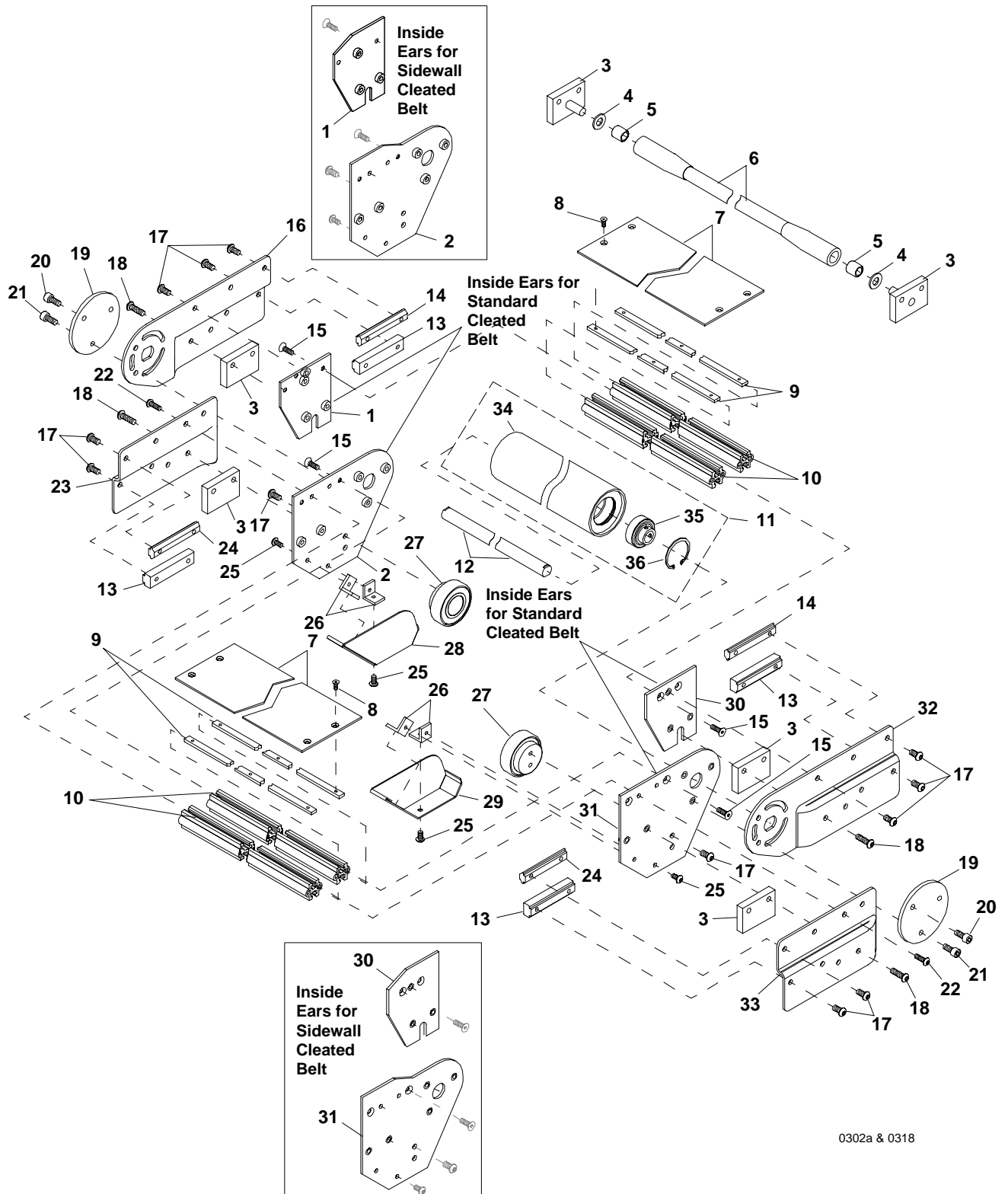

0302a & 0318

Replacement Parts

LPZ Cleated Belt Conveyors

Item	Part No.	Part Description
1	300637M	Inside Ear, Short, Left Hand, Low Side (Standard Cltd.)
	300640M	Inside Ear, Short, Left Hand, High Side (Sidewall Cltd.)
2	300584M	Inside Ear, Pivot, Top, Left Hand, Low Side (Standard Cltd.)
	300421M	Inside Ear, Pivot, Top, Left Hand, High Side (Sidewall Cltd.)
3	300635M	Ears Roller Mounting Spacer Plate [18 & 24" (457 & 610 mm) Wide Conveyors Only]
	300528M	Ears Spacer Block [8 & 12" (203 & 305 mm)] Wide Conveyors Only
4	300160P	Nylon Washer [18 & 24" (457 & 610 mm) Wide Conveyors Only]
5	802-073	Sealed Needle Bearing [18 & 24" (457 & 610 mm) Wide Conveyors Only]
6	300671M	Return Roller Ass'y 18" (457 mm)
	300672M	Return Roller Ass'y 24" (610 mm)
7	315408	Bedplate LPZ 8" (203 mm) Wide
	315406	Bedplate LPZ 6" (152 mm) Wide
	315418	Bedplate LPZ 18" (457 mm) Wide
8	300353MP	Bedplate Screw, M4-0.70 x 10 mm
9	207210M	Rail Nut Strip 10" (254 mm) Wide
	207208M	Rail Nut Strip 8" (203 mm) Wide
	307206M	Rail Nut Strip 6" (152 mm) Wide
10	305208M	Bottom Guard Center Rail 8" (203 mm)
	305212M	Bottom Guard Center Rail 12" (305 mm)
	305218M	Bottom Guard Center Rail 18" (457 mm)
	305224M	Bottom Guard Center Rail 24" (610 mm)
11	326708	3" (76 mm) Dia. Idler Ass'y, 8" (203 mm)
	326712	3" (76 mm) Dia. Idler Ass'y, 12" (305 mm)
	326718	3" (76 mm) Dia. Idler Ass'y, 18" (457 mm)
	326724	3" (76 mm) Dia. Idler Ass'y, 24" (610 mm)
12	301908	Idler Shaft 8" (203 mm) Wide
	301912	Idler Shaft 12" (305 mm) Wide
	301918	Idler Shaft 18" (457 mm) Wide
	301924	Idler Shaft 24" (610 mm) Wide

Item	Part No.	Part Description
13	300152M	T-bar
14	300536M	Drop-In T-bar
15	930512M	Flat Head Cap Screw, M5-0.80 x 12 mm
16	300498M	Cover Plate, Slotted, Left Hand, 8" (203 mm) & 12" (305 mm)
	300975M	Cover Plate, Slotted, Left Hand, 18" (457 mm) & 24" (610 mm)
17	910612M	Button Head Cap Screw, M6-1.0 x 12 mm
18	910620M	Button Head Cap Screw, M6-1.0 x 20 mm
19	300657M	Slots Cover Disc
20	920614M	Socket Head Cap Screw, M6-1.0 x 14 mm
21	300420MP	Socket Head Cap Screw, M6-1.0 x 14 mm (Gold)
22	910516M	Button Head Cap Screw, M5-0.80 x 16 mm
23	300496M	Cover Plate, Short, Left Hand
24	300150M	Drop-In T-bar
25	910510M	Button Head Cap Screw, M5-0.80 x 10 mm
26	300667M	Guard Mounting Angle
27	300495M	Bearing Nut Axle
28	300666M	Bearing Bent Cover, Left Hand
29	300665M	Bearing Bent Cover, Right Hand
30	300639M	Inside Ear, Short, Right Hand, High Side (Sidewall Cltd.)
	300636M	Inside Ear, Short, Right Hand, Low Side (Standard Cltd.)
31	300585M	Inside Ear, Pivot, Top, Right Hand, Low Side (Standard Cltd.)
	300422M	Inside Ear, Pivot, Top, Right Hand, High Side (Sidewall Cltd.)
32	300499M	Cover Plate, Slotted, Right Hand, 8" (203 mm) & 12" (305 mm)
	300976M	Cover Plate, Slotted, Right Hand, 18" (457 mm) & 24" (610 mm)
33	300497M	Cover Plate, Short, Right Hand
34	326608	Aluminum Pulley Tube, 8" (203 mm)
	326612	Aluminum Pulley Tube, 12" (305 mm)
	326618	Aluminum Pulley Tube, 18" (457 mm)
	326624	Aluminum Pulley Tube, 24" (610 mm)
35	802-110	Ball Bearing (Set Screws Removed)
36	915-051	Retaining Ring

Horizontal to Incline Transition Module Assemblies

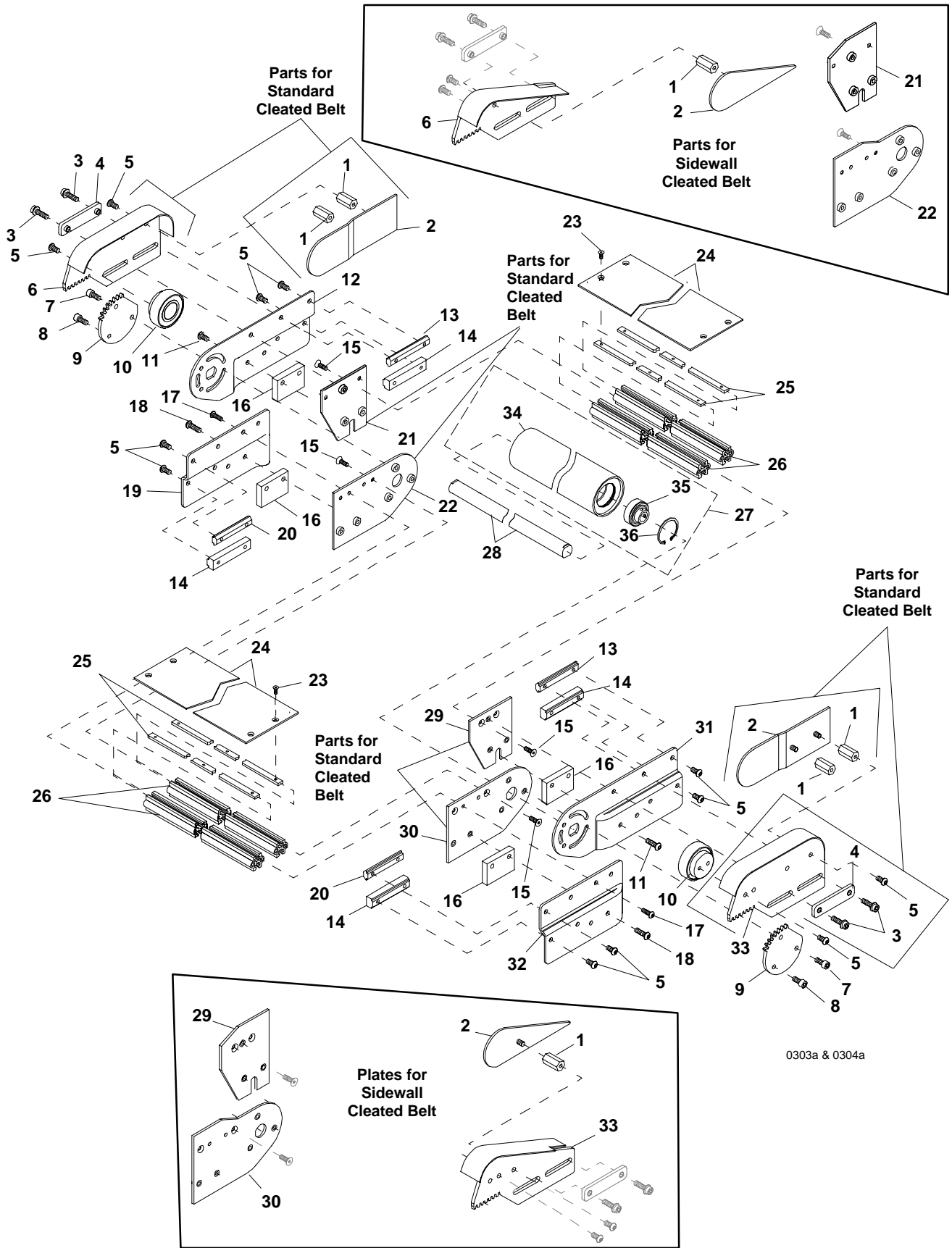

0303a & 0304a

Replacement Parts

LPZ Cleated Belt Conveyors

Item	Part No.	Part Description
1	300596M	Hex Post
2	300597M	Offset Guide Plate (Standard Cltd.)
	300653M	Bearing Cover Plate (Sidewall Cltd.)
3	969900M	Socket Head Cap Screw, M6-1.0 x 20 mm
4	300546M	Cover Plate
5	910612M	Button Head Cap Screw, M6-1.0 x 12 mm
6	300521M	Roller Guard Rack Ass'y, Left (Standard Cltd.)
	300526M	Roller Guard Rack Ass'y, Left (Sidewall Cltd.)
7	920614M	Socket Head Cap Screw, M6-1.0 x 14 mm
8	300420M P	Socket Head Cap Screw, M6-1.0 x 14 mm (Gold)
9	300538M	Top Roller Moving Gear
10	300495M	Bearing Nut Axle
11	910620M	Button Head Cap Screw, M6-1.0 x 20 mm
12	300498M	Cover Plate, Slotted, Left Hand, 8" (203 mm) & 12" (305 mm)
	300977M	Cover Plate, Slotted, Left Hand, 18" (457 mm) & 24" (610 mm)
13	300536M	Drop-In T-bar
14	300152M	T-bar
15	930512M	Flat Head Cap Screw, M5-0.80 x 12 mm
16	300528M	Ears Spacer Block
17	910516M	Button Head Cap Screw, M5-0.80 x 16 mm
18	910620M	Button Head Cap Screw, M6-1.0 x 20 mm
19	300496M	Cover Plate, Short, Left Hand
20	300150M	Drop-In T-bar
21	300637M	Inside Ear, Short, Left Hand, Low Side (Standard Cltd.)
	300640M	Inside Ear, Short, Left Hand, High Side (Sidewall Cltd.)
22	300582M	Inside Ear, Pivot, Bottom, Left Hand, Low Side (Standard Cltd.)
	300580M	Inside Ear, Pivot, Bottom, Left Hand, High Side (Sidewall Cltd.)
23	300353M P	Bedplate Screw, M4-0.70 x 10 mm
24	315408	Bedplate LPZ 8" (203 mm) Wide
	315406	Bedplate LPZ 6" (152 mm) Wide
	315418	Bedplate LPZ 18" (457 mm) Wide

Item	Part No.	Part Description
25	207210M	Rail Nut Strip 10" (254 mm) Wide
	207208M	Rail Nut Strip 8" (203 mm) Wide
	307206M	Rail Nut Strip 6" (152 mm) Wide
26	305208M	Bottom Guard Center Rail 8" (203 mm)
	305212M	Bottom Guard Center Rail 12" (305 mm)
	305218M	Bottom Guard Center Rail 18" (457 mm)
	305224M	Bottom Guard Center Rail 24" (610 mm)
27	326708	3" (76 mm) Dia. Idler Ass'y, 8" (203 mm)
	326712	3" (76 mm) Dia. Idler Ass'y, 12" (305 mm)
	326718	3" (76 mm) Dia. Idler Ass'y, 18" (457 mm)
	326724	3" (76 mm) Dia. Idler Ass'y, 24" (610 mm)
28	301908	Idler Shaft 8" (203 mm) Wide
	301912	Idler Shaft 12" (305 mm) Wide
	301918	Idler Shaft 18" (457 mm) Wide
	301924	Idler Shaft 24" (610 mm) Wide
29	300636M	Inside Ear, Short, Right Hand, Low Side (Standard Cltd.)
	300639M	Inside Ear, Short, Right Hand, High Side (Sidewall Cltd.)
30	300583M	Inside Ear, Pivot, Bottom, Right Hand, Low Side (Standard Cltd.)
	300581M	Inside Ear, Pivot, Bottom, Right Hand, High Side (Sidewall Cltd.)
31	300499M	Cover Plate, Slotted, Right Hand, 8" (203 mm) & 12" (305 mm)
	300978M	Cover Plate, Slotted, Right Hand, 18" (457 mm) & 24" (610 mm)
32	300497M	Cover Plate, Short, Right Hand
33	300522M	Roller Guard Rack Ass'y, Right (Standard Cltd.)
	300527M	Roller Guard Rack Ass'y, Right (Sidewall Cltd.)
34	326608	Aluminum Pulley Tube, 8" (203 mm)
	326612	Aluminum Pulley Tube, 12" (305 mm)
	326618	Aluminum Pulley Tube, 18" (457 mm)
	326624	Aluminum Pulley Tube, 24" (610 mm)
35	802-110	Ball Bearing (Set Screws Removed)
36	915-051	Retaining Ring

Standard Cleated Belt Conveyor Guiding

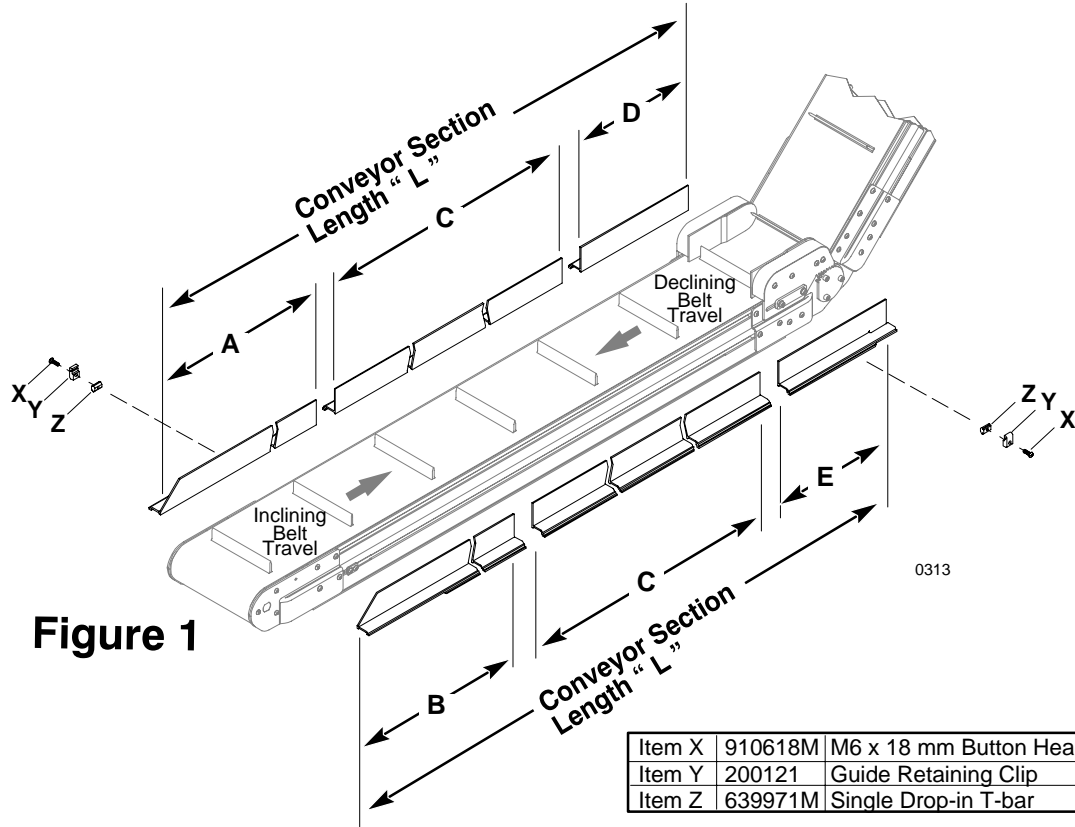
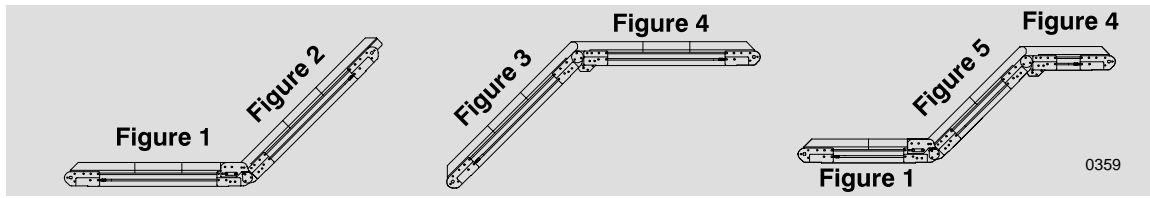

Item X	910618M	M6 x 18 mm Button Head Cap Screw
Item Y	200121	Guide Retaining Clip
Item Z	639971M	Single Drop-in T-bar

Section Length "L"	Tail Section		Intermediate Section	Transition Section with Inclining Belt Travel		Transition Section with Declining Belt Travel	
	"A"	"B"		"D"	"E"	"D"	"E"
2 ft (610 mm)	None	None	None	382041	382040	382158	382159
3 ft (915 mm)	382015	382014	None	382019	382018	382020	382021
4 ft (1220 mm)	382017	382016	None	382019	382018	382020	382021
5 ft (1525 mm)	382015	382014	382074	382019	382018	382020	382021
6 ft (1830 mm)	382017	382016	382074	382019	382018	382020	382021
7 ft (2135 mm)	382015	382014	382075	382019	382018	382020	382021
8 ft (2440 mm)	382017	382016	382075	382019	382018	382020	382021
9 ft (2745 mm)	382015	382014	382076	382019	382018	382020	382021
10 ft (3050 mm)	382017	382016	382076	382019	382018	382020	382021
11 ft (3355 mm)	382015	382014	382077	382019	382018	382020	382021
12 ft (3660 mm)	382017	382016	382077	382019	382018	382020	382021
13 ft (3965 mm)	382015	382014	382078	382019	382018	382020	382021

Standard Cleated Belt Conveyor Guiding

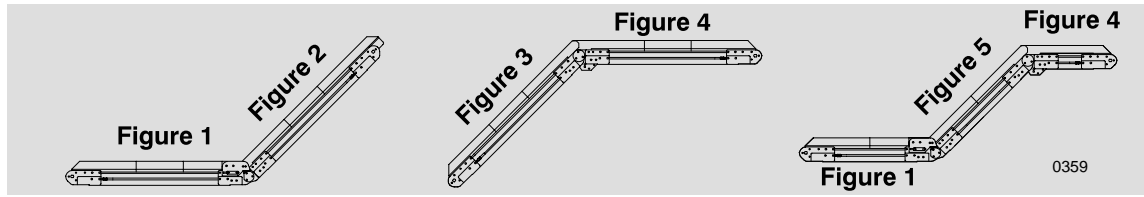

Item U	910506M	M5 x 6 mm Button Head Screw
Item V	382094M	Extension Exit Guide, Left
Item W	382095M	Extension Exit Guide, Right
Item X	910618M	M6 x 18 mm Button Head Cap Screw
Item Y	200121	Guide Retaining Clip
Item Z	639971M	Single Drop-in T-bar

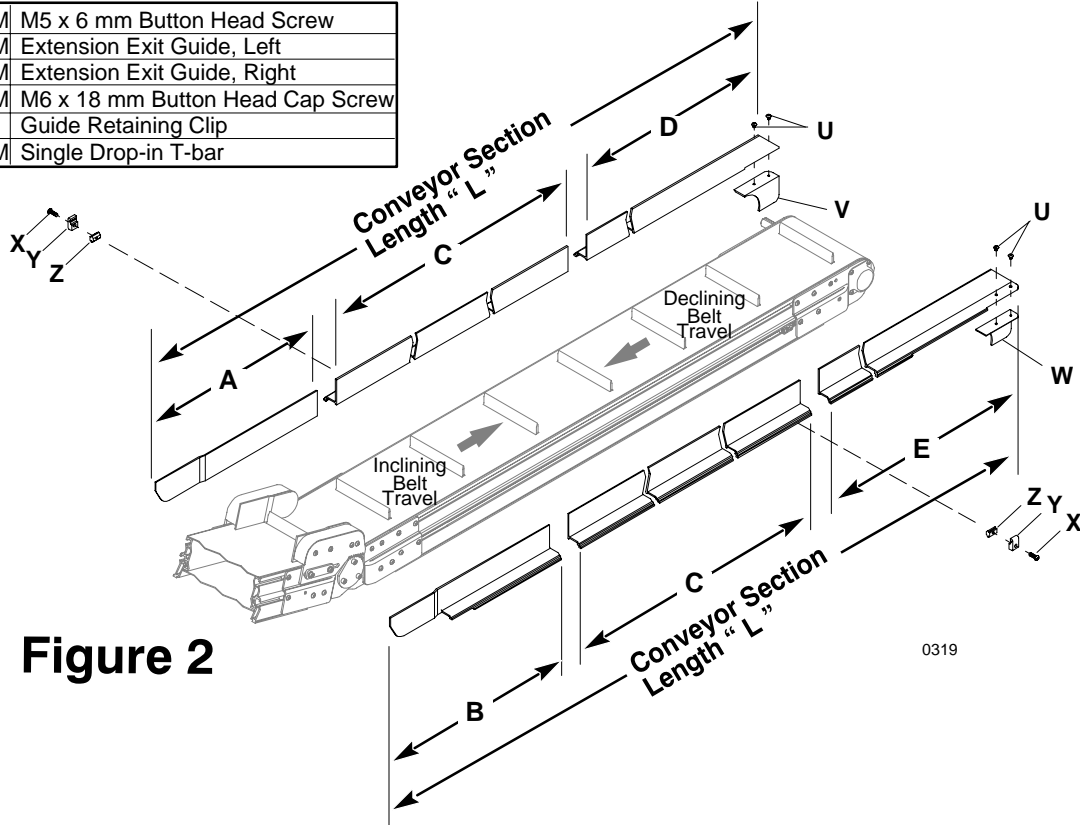

Figure 2

Section Length "L"	Transition Section with Inclining Belt Travel		Transition Section with Declining Belt Travel		Intermediate Section "C"	Tail Section with Inclining Belt Travel		Tail Section with Declining Belt Travel	
	"A"	"B"	"A"	"B"		"D"	"E"	"D"	"E"
2 ft (610 mm)	382058	382059	382040	382041	None	None	None	None	None
3 ft (915 mm)	382021	382020	382018	382019	None	382097	382096	382014	382015
4 ft (1220 mm)	382021	382020	382018	382019	None	382099	382098	382016	382017
5 ft (1525 mm)	382021	382020	382018	382019	382074	382097	382096	382014	382015
6 ft (1830 mm)	382021	382020	382018	382019	382074	382099	382098	382016	382017
7 ft (2135 mm)	382021	382020	382018	382019	382075	382097	382096	382014	382015
8 ft (2440 mm)	382021	382020	382018	382019	382075	382099	382098	382016	382017
9 ft (2745 mm)	382021	382020	382018	382019	382076	382097	382096	382014	382015
10 ft (3050 mm)	382021	382020	382018	382019	382076	382099	382098	382016	382017
11 ft (3355 mm)	382021	382020	382018	382019	382077	382097	382096	382014	382015
12 ft (3660 mm)	382021	382020	382018	382019	382077	382099	382098	382016	382017
13 ft (3965 mm)	382021	382020	382018	382019	382078	382097	382096	382014	382015

Standard Cleated Belt Conveyor Guiding

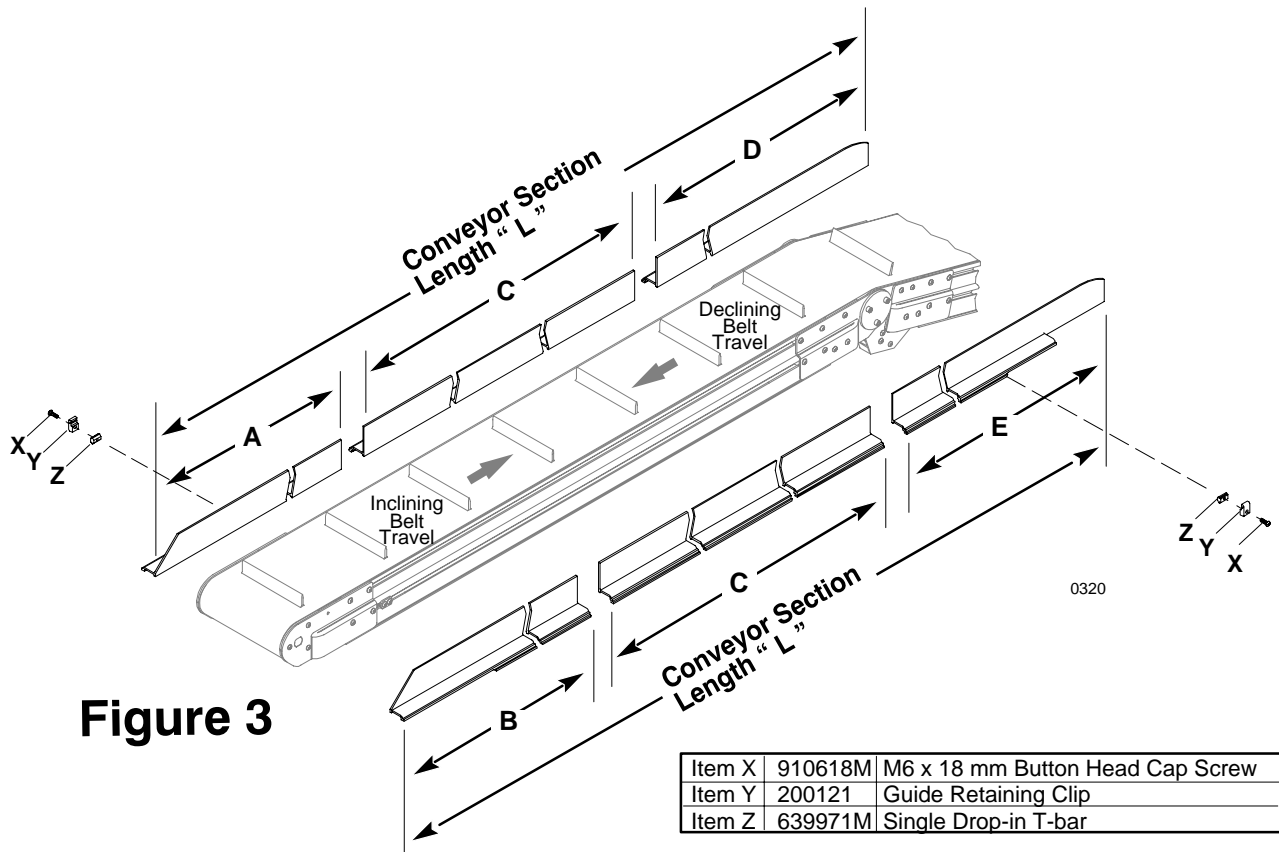
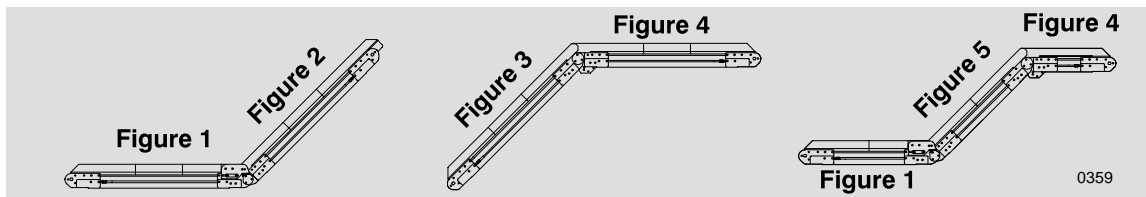

Figure 3

Item X	910618M	M6 x 18 mm Button Head Cap Screw
Item Y	200121	Guide Retaining Clip
Item Z	639971M	Single Drop-in T-bar

Section Length "L"	Tail Section		Intermediate Section	Transition Section with Inclining Belt Travel		Transition Section with Declining Belt Travel	
	"A"	"B"		"D"	"E"	"D"	"E"
2 ft (610 mm)	None	None	None	382060	382061	382054	382055
3 ft (915 mm)	382015	382014	None	382035	382034	382038	382039
4 ft (1220 mm)	382017	382016	None	382035	382034	382038	382039
5 ft (1525 mm)	382015	382014	382074	382035	382034	382038	382039
6 ft (1830 mm)	382017	382016	382074	382035	382034	382038	382039
7 ft (2135 mm)	382015	382014	382075	382035	382034	382038	382039
8 ft (2440 mm)	382017	382016	382075	382035	382034	382038	382039
9 ft (2745 mm)	382015	382014	382076	382035	382034	382038	382039
10 ft (3050 mm)	382017	382016	382076	382035	382034	382038	382039
11 ft (3355 mm)	382015	382014	382077	382035	382034	382038	382039
12 ft (3660 mm)	382017	382016	382077	382035	382034	382038	382039
13 ft (3965 mm)	382015	382014	382078	382035	382034	382038	382039

Standard Cleated Belt Conveyor Guiding

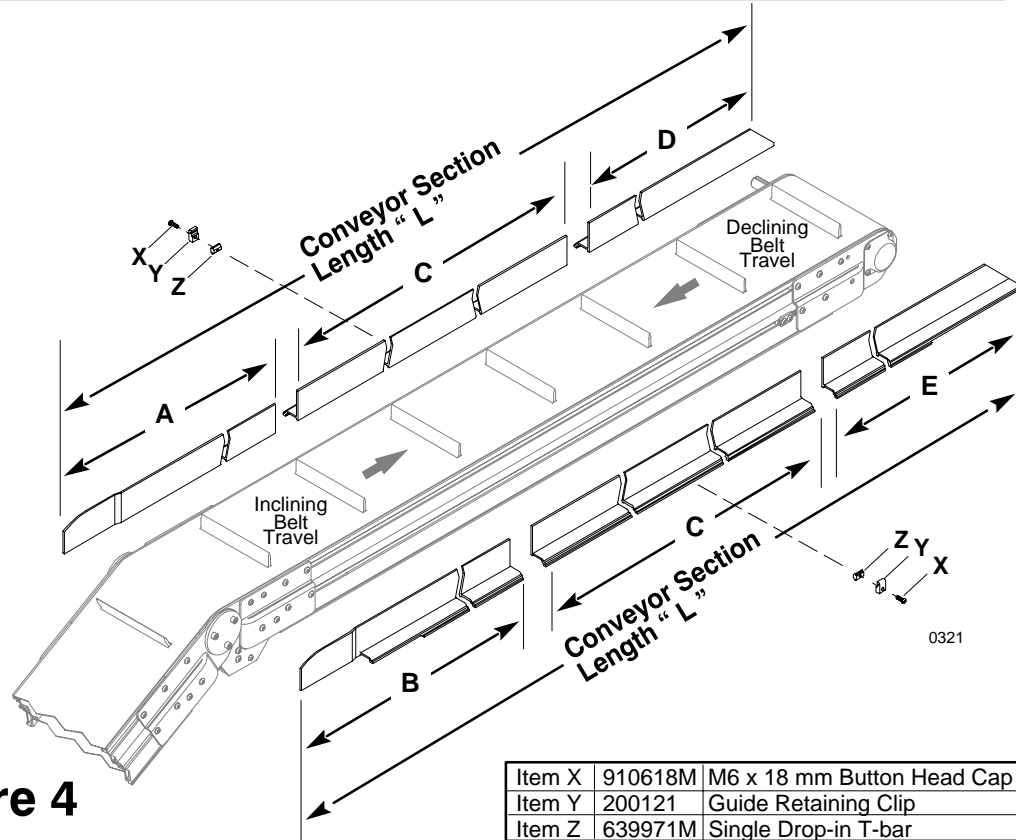
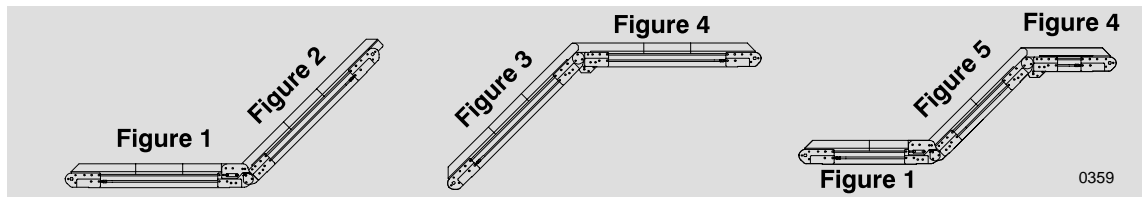

Figure 4

Item X	910618M	M6 x 18 mm Button Head Cap Screw
Item Y	200121	Guide Retaining Clip
Item Z	639971M	Single Drop-in T-bar

Section Length "L"	Transition Section with Inclining Belt Travel		Transition Section with Declining Belt Travel		Intermediate Section "C"	Tail Section	
	"A"	"B"	"A"	"B"		"D"	"E"
2 ft (610 mm)	382055	382054	382061	382060	None	None	None
3 ft (915 mm)	382039	382038	382034	382035	None	382015	382014
4 ft (1220 mm)	382039	382038	382034	382035	None	382017	382016
5 ft (1525 mm)	382039	382038	382034	382035	382074	382015	382014
6 ft (1830 mm)	382039	382038	382034	382035	382074	382017	382016
7 ft (2135 mm)	382039	382038	382034	382035	382075	382015	382014
8 ft (2440 mm)	382039	382038	382034	382035	382075	382017	382016
9 ft (2745 mm)	382039	382038	382034	382035	382076	382015	382014
10 ft (3050 mm)	382039	382038	382034	382035	382076	382017	382016
11 ft (3355 mm)	382039	382038	382034	382035	382077	382015	382014
12 ft (3660 mm)	382039	382038	382034	382035	382077	382017	382016
13 ft (3965 mm)	382039	382038	382034	382035	382078	382015	382014

Standard Cleated Belt Conveyor Guiding

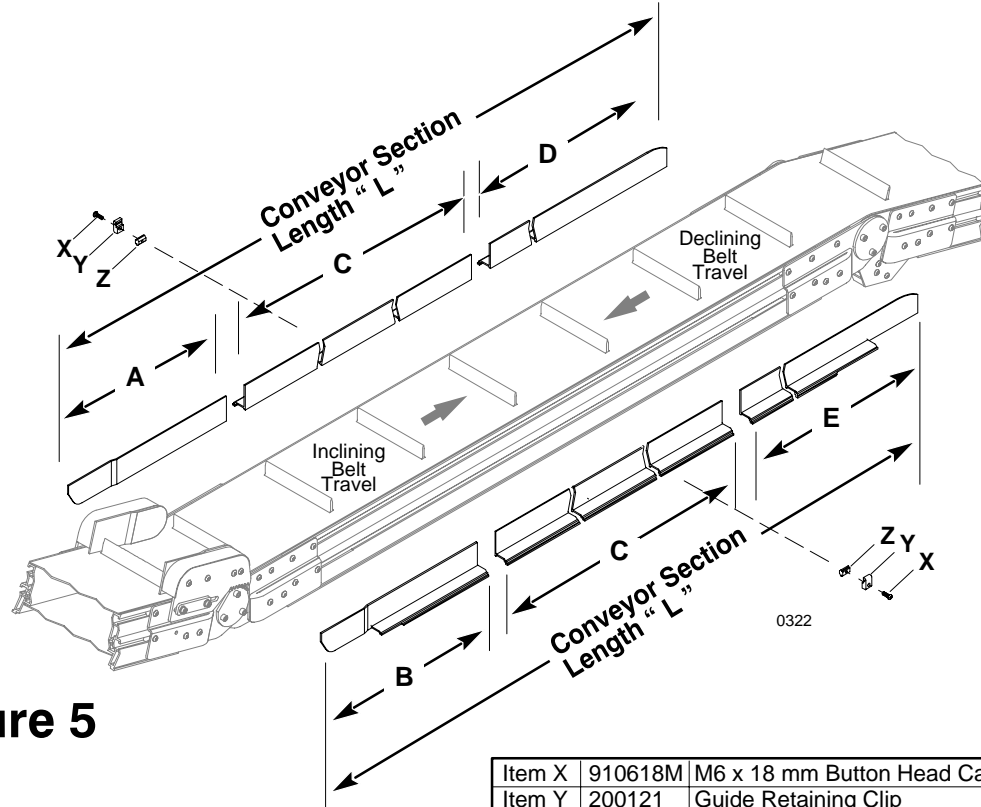
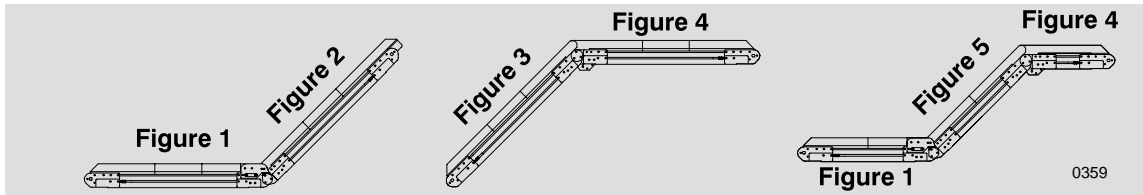
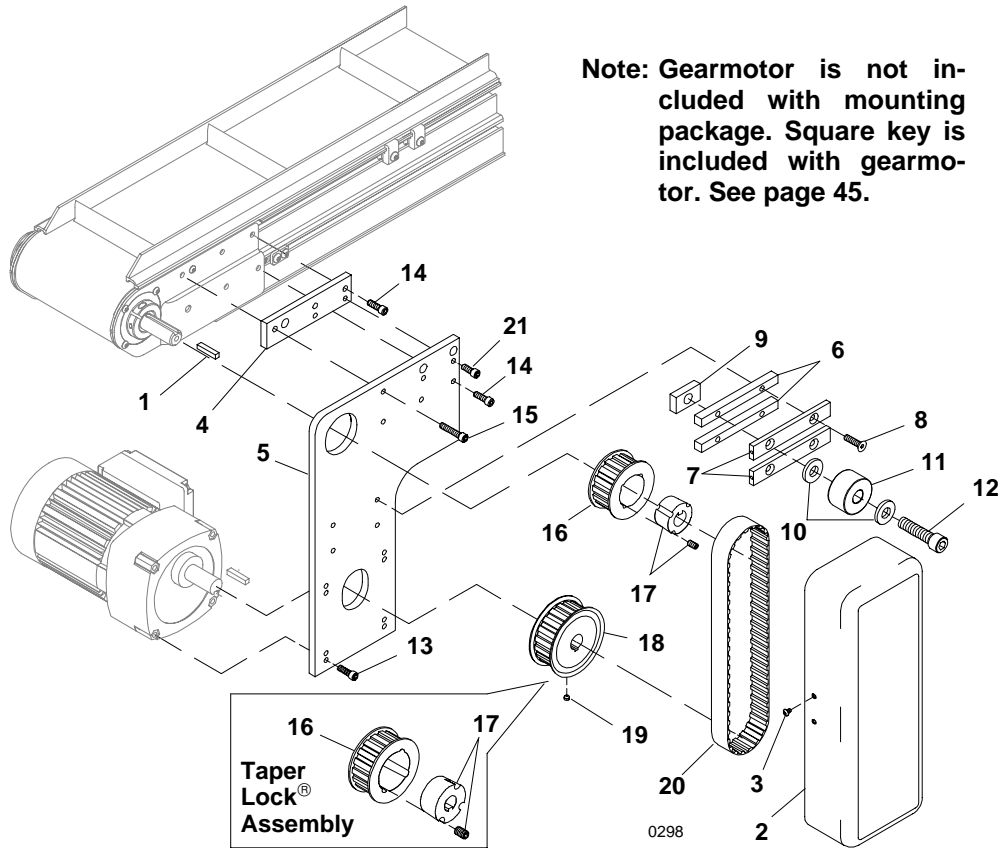

Figure 5

Item X	910618M	M6 x 18 mm Button Head Cap Screw
Item Y	200121	Guide Retaining Clip
Item Z	639971M	Single Drop-in T-bar

Section Length "L"	Lower Transition Section with Inclining Belt Travel		Lower Transition Section with Declining Belt Travel		Intermediate Section "C"	Upper Transition Section with Inclining Belt Travel		Upper Transition Section with Declining Belt Travel	
	"A"	"B"	"A"	"B"		"D"	"E"	"D"	"E"
2 ft (610 mm)	None	None	None	None	None	382056	382057	382156	382157
3 ft (915 mm)	382021	382020	382018	382019	None	382035	382034	382038	382039
4 ft (1220 mm)	382021	382020	382018	382019	None	382036	382037	382138	382139
5 ft (1525 mm)	382021	382020	382018	382019	382074	382035	382034	382038	382039
6 ft (1830 mm)	382021	382020	382018	382019	382074	382036	382037	382138	382139
7 ft (2135 mm)	382021	382020	382018	382019	382075	382035	382034	382038	382039
8 ft (2440 mm)	382021	382020	382018	382019	382075	382036	382037	382138	382139
9 ft (2745 mm)	382021	382020	382018	382019	382076	382035	382034	382038	382039
10 ft (3050 mm)	382021	382020	382018	382019	382076	382036	382037	382138	382139
11 ft (3355 mm)	382021	382020	382018	382019	382077	382035	382034	382038	382039
12 ft (3660 mm)	382021	382020	382018	382019	382077	382036	382037	382138	382139
13 ft (3965 mm)	382021	382020	382018	382019	382078	382035	382034	382038	382039

Cleated Belt Bottom Mounting Package Exploded-view



Item	Part No.	Part Description
1	980018M	Square Key (Undersized), 6 mm x 18 mm
2	310046M	Bottom Drive Cover (Cleated Belt)
3	910410M	Button Head Cap Screw, M4-0.70 x 10 mm
4	300038M	Spacer, 3/8 Thick
5	310035M	Drive Bottom Mounting Plate (Cleated Belt)
6	300187	Idler Spacer Bar
7	300186M	Idler Guide Bar
8	930625M	Flat Head Cap Screw, M6-1.0 x 25 mm
9	628144M	Cam Follower Nut
10	605284	Hard Washer, Black Oxide
11	802-059	Cam Follower Bearing
12	921250M	Socket Head Cap Screw, M12-1.75 x 50 mm
13	920625M	Socket Head Cap Screw, M6-1.0 x 25 mm
14	920620M	Socket Head Cap Screw, M6-1.0 x 20 mm
15	920630M	Socket Head Cap Screw, M6-1.0 x 30 mm

Item	Part No.	Part Description
16	811-126	Pulley, 16 Tooth, Taper Lock®, TL-1108
	811-127	Pulley, 18 Tooth, Taper Lock®, TL-1210
	811-133	Pulley, 14 Tooth, Taper Lock®, TL-1108
	811-135	Pulley, 20 Tooth, Taper Lock®, TL-1210
	811-136	Pulley, 22 Tooth, Taper Lock®, TL-1610
	811-137	Pulley, 24 Tooth, Taper Lock®, TL-1610
17	811-206	Taper Lock® Bushing, TL-1610, 19 mm Bore
	811-205	Taper Lock® Bushing, TL-1210, 19 mm Bore
	811-204	Taper Lock® Bushing, TL-1108, 19 mm Bore
18	300049M	Drive Pulley, 19 Tooth, 19 mm Bore
19	970608M	Socket Head Set Screw, M6-1.0 x 8 mm
20	814-059	Timing Belt, 27" (685 mm) Long
	814-060	Timing Belt, 28" (711 mm) Long
21	920616M	Socket Head Cap Screw, M6-1.0 x 16 mm

Cleated Belt Side Mounting Package Exploded-view

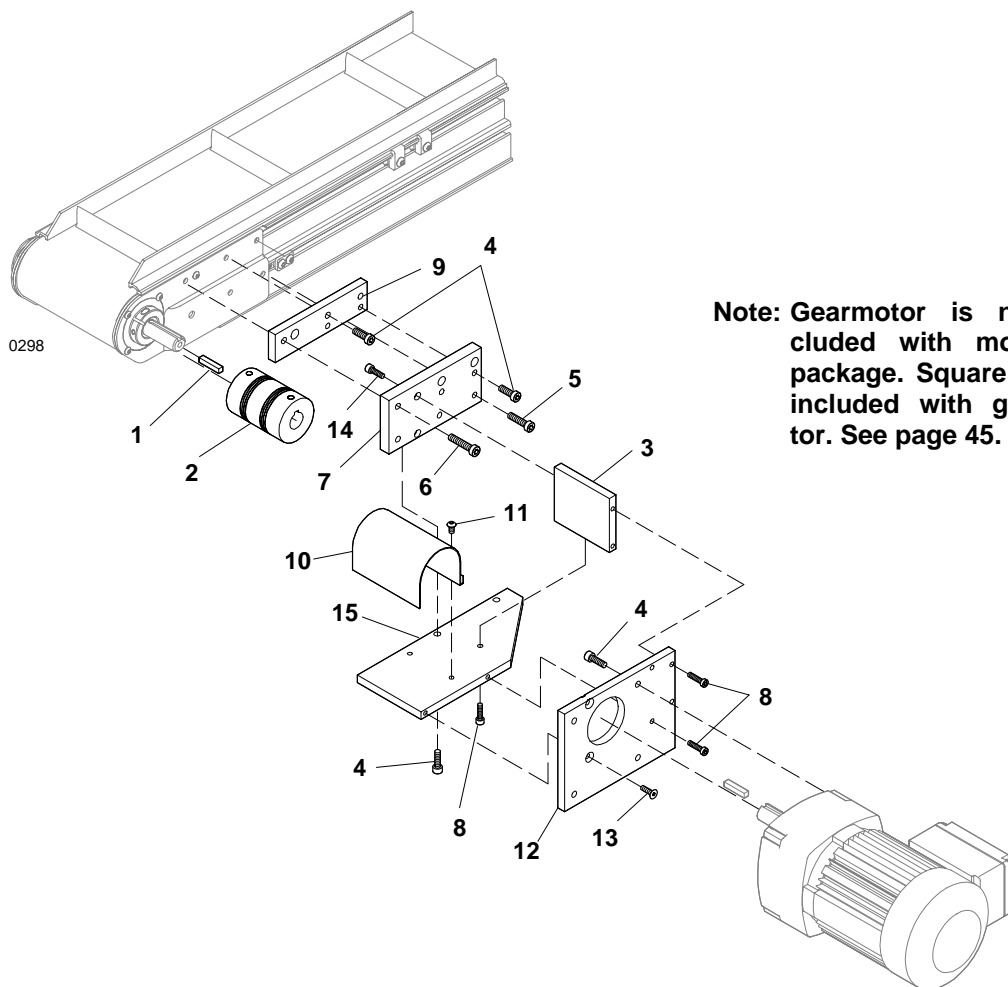

Note: Gearmotor is not included with mounting package. Square key is included with gearmotor. See page 45.

Item	Part No.	Part Description
1	980018M	Square Key (Undersized), 6 mm x 18 mm
2	807-102 6	Flexible Coupling, 19 mm
3	310047M	Side Drive Gusset
4	920620M	Socket Head Cap Screw, M6-1.0 x 20 mm
5	920625M	Socket Head Cap Screw, M6-1.0 x 25 mm
6	920635M	Socket Head Cap Screw, M6-1.0 x 35 mm
7	310039M	Side Drive Mounting Plate
8	920520M	Socket Head Cap Screw, M5-0.80 x 20 mm

Item	Part No.	Part Description
9	300038M	Spacer, 3/8, Thick
10	310048M	Side Drive Guard
11	910510M	Button Head Cap Screw, M5-0.80 x 10 mm
12	310041M	Gearmotor Mounting Plate
13	930518M	Flat Head Cap Screw, M5-0.80 x 18 mm
14	920518M	Socket Head Cap Screw, M5-0.80 x 18 mm
15	310042M	Side Drive Plate

Cleated Belt Top Mounting Package Exploded-view

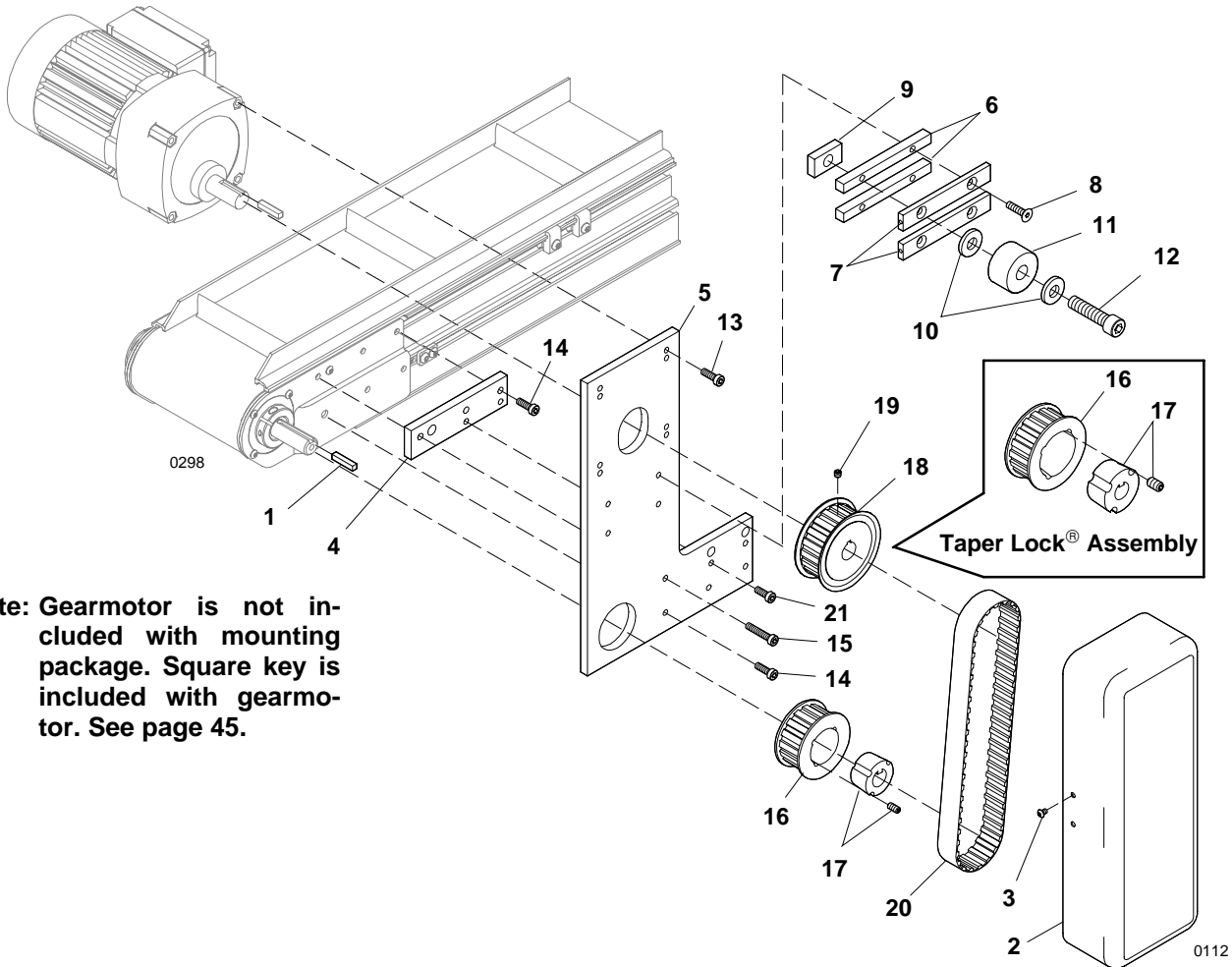

Note: Gearmotor is not included with mounting package. Square key is included with gearmotor. See page 45.

Item	Part No.	Part Description
1	980018M	Square Key (Undersided), 6 mm x 18 mm
2	310046M	Top Drive Cover
3	910410M	Button Head Cap Screw, M4-0.70 x 10 mm
4	300038M	Spacer, 3/8 Thick
5	310045M	Drive Top Mounting Plate
6	300187	Idler Spacer Bar
7	300186M	Idler Guide Bar
8	930625M	Flat Head Cap Screw, M5-1.0 x 25 mm
9	628144M	Cam Follower Nut
10	605284	Hard Washer, Black Oxide
11	802-059	Cam Follower Bearing
12	921250M	Socket Head Cap Screw, M12-1.75 x 50 mm
13	920625M	Socket Head Cap Screw, M6-1.0 x 25 mm
14	920620M	Socket Head Cap Screw, M6-1.0 x 20 mm
15	920630M	Socket Head Cap Screw, M6-1.0 x 30 mm

Item	Part No.	Part Description
16	811-126	Pulley, 16 Tooth, Taper Lock®, TL-1108
	811-127	Pulley, 18 Tooth, Taper Lock®, TL-1210
	811-133	Pulley, 14 Tooth, Taper Lock®, TL-1108
	811-135	Pulley, 20 Tooth, Taper Lock®, TL-1210
	811-136	Pulley, 22 Tooth, Taper Lock®, TL-1610
	811-137	Pulley, 24 Tooth, Taper Lock®, TL-1610
17	811-206	Taper Lock® Bushing, TL-1610, 19 mm Bore
	811-205	Taper Lock® Bushing, TL-1210, 19 mm Bore
	811-204	Taper Lock® Bushing, TL-1108, 19 mm Bore
18	300049M	Drive Pulley, 19 Tooth, 19 mm Bore
19	970608M	Socket Head Set Screw, M6-1.0 x 8 mm
20	814-059	Timing Belt, 27" (685 mm) Long
	814-060	Timing Belt, 28" (711 mm) Long
21	920616M	Socket Head Cap Screw, M6-1.0 x 16 mm

Gearmotors

**Fixed Speed
Single-phase
115 Volt A.C.
60 Hz Motor**

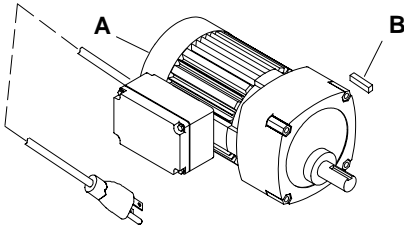

**Fixed Speed
Three-phase
230/460 Volts A.C.
60 HZ Motor**

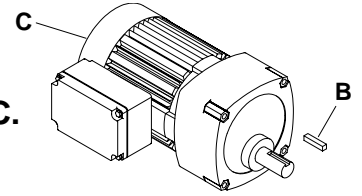

Item	Motor Part No.	hp	Gear Ratio	Output RPM	Torque In-Lb
A	62M180PS411F(n)	0.08	180:1	9.4	341
	62M060PS411F(n)	0.17	60:1	28	270
	32M030PS411F(n)	0.33	30:1	57	250
	32M020PS411F(n)	0.33	20:1	85	167
	32M010PS411F(n)	0.33	10:1	170	108
	32M005PS411F(n)	0.33	5:1	340	56
B	912-080	3/16" x 1" Square Key			

Item	Motor Part No.	hp	Gear Ratio	Output RPM	Torque In-Lb
B	912-080	3/16" x 1" Square Key			
C	62M060PS423FN*	0.25	60:1	28	270
	32M030PS423FN	0.5	30:1	57	250
	32M020PS423FN	0.5	20:1	85	167
	32M010PS423FN	0.5	10:1	170	108

* Not available in 460 voltage.

- (n) = Reversing Capacity
- N = Non-Reversing
- R = Reversing

130 volt D.C. Variable Speed Motors & 115 volt A.C., 60 Hz. Controllers

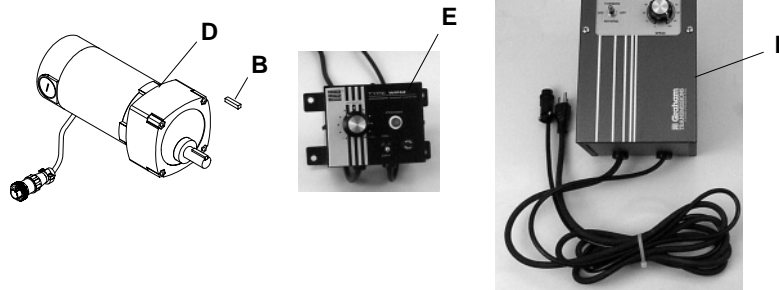

Item	Motor Part No.	hp	Gear Ratio	Output RPM	Torque In-Lb
B	912-080	3/16" x 1" Square Key			
D	62M180PSD3DEN	0.12	180:1	14	341
	62M060PSD3DEN	0.25	60:1	42	270
	62M030PSD3DEN	0.25	30:1	83	135
	62M020PSD3DEN	0.25	20:1	125	90
	62M010PSD3DEN	0.33	10:1	250	72

Item	Controller Part No.	Reversing	Amperes	Input
E	62MD1134	no	3	115 Volts, 60 Hz Single Phase
F	62MD1134R	yes	5	

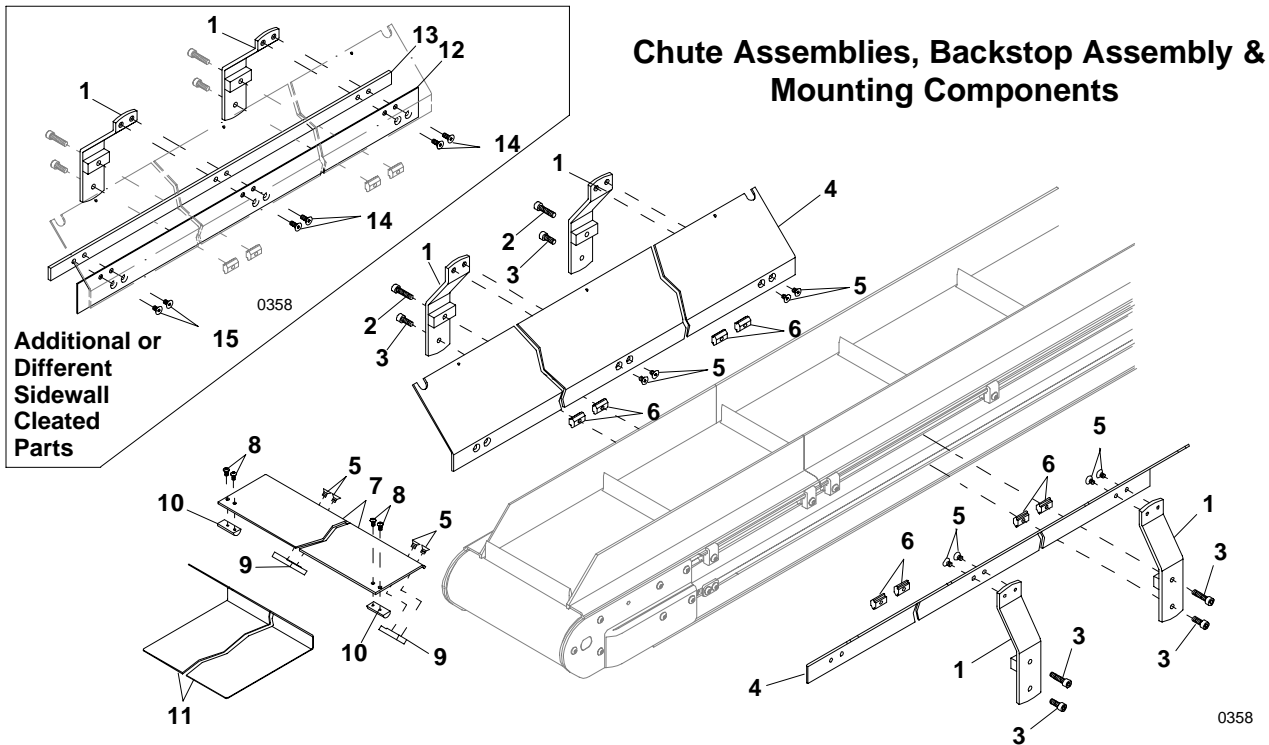

Item	Part No.	Part Description
1	300743M	Chute Support Plate Ass'y (Standard)
	300744M	Chute Support Plate Ass'y (Sidewall)
2	920625M	Socket Head Cap Screw, M6-1.0 x 25 mm
3	920616M	Socket Head Cap Screw, M6-1.0 x 16 mm
4	300695M	2 ft (610 mm) Long Flared Side Guide
	300696M	3 ft (915 mm) Long Flared Side Guide
	300697M	4 ft (1220 mm) Long Flared Side Guide
5	930508M	Flat Head Cap Screw, M5-0.80 x 8 mm (Standard Cld. Only)
6	639971M	Single Drop-in T-bar
7	300831M	Chute Back Guide 8" (203 mm) (Standard)
	300835M	Chute Back Guide 8" (203 mm) (Sidewall)
	300832M	Chute Back Guide 12" (305 mm) (Standard)
	300836M	Chute Back Guide 12" (305 mm) (Sidewall)
	300833M	Chute Back Guide 18" (457 mm) (Standard)
	300837M	Chute Back Guide 18" (457 mm) (Sidewall)
	300834M	Chute Back Guide 24" (610 mm) (Standard)
	300838M	Chute Back Guide 24" (610 mm) (Sidewall)
8	910408M	Button Head Cap Screw, M4-0.70 x 8 mm

Item	Part No.	Part Description
9	300741M	Clamp Block
10	300774M	Knock Out Pin
11	300841M	Cleat Cover Guide 8" (203 mm) (Standard)
	300845M	Cleat Cover Guide 8" (203 mm) (Sidewall)
	300842M	Cleat Cover Guide 12" (305 mm) (Standard)
	300846M	Cleat Cover Guide 12" (305 mm) (Sidewall)
	300843M	Cleat Cover Guide 18" (457 mm) (Standard)
	300847M	Cleat Cover Guide 18" (457 mm) (Sidewall)
	300844M	Cleat Cover Guide 24" (610 mm) (Standard)
	300848M	Cleat Cover Guide 24" (610 mm) (Sidewall)
12	300649	2 ft (610 mm) Long Wiper Guide (Sidewall)
	300745	3 ft (915 mm) Long Wiper Guide (Sidewall)
	300746	4 ft (1220 mm) Long Wiper Guide (Sidewall)
13	300859M	2 ft (610 mm) Long Wiper Clamp (Sidewall)
	300860M	3 ft (915 mm) Long Wiper Clamp (Sidewall)
	300861M	4 ft (1220 mm) Long Wiper Clamp (Sidewall)
14	930516M	Flat Head Cap Screw, M5-0.80 x 16 mm (Sidewall)
	930510M	Flat Head Cap Screw, M5-0.80 x 10 mm (Sidewall)

Conveyor Belt Part Number

For replacement belting on your cleated conveyor, contact factory with conveyor model and serial numbers. These numbers are located on the side rail of your conveyor and

should be recorded on page 3 in the spaces provided. The address and phone numbers are listed on the back cover of this manual.

Tool Kit - Part Number 2500M-ENG

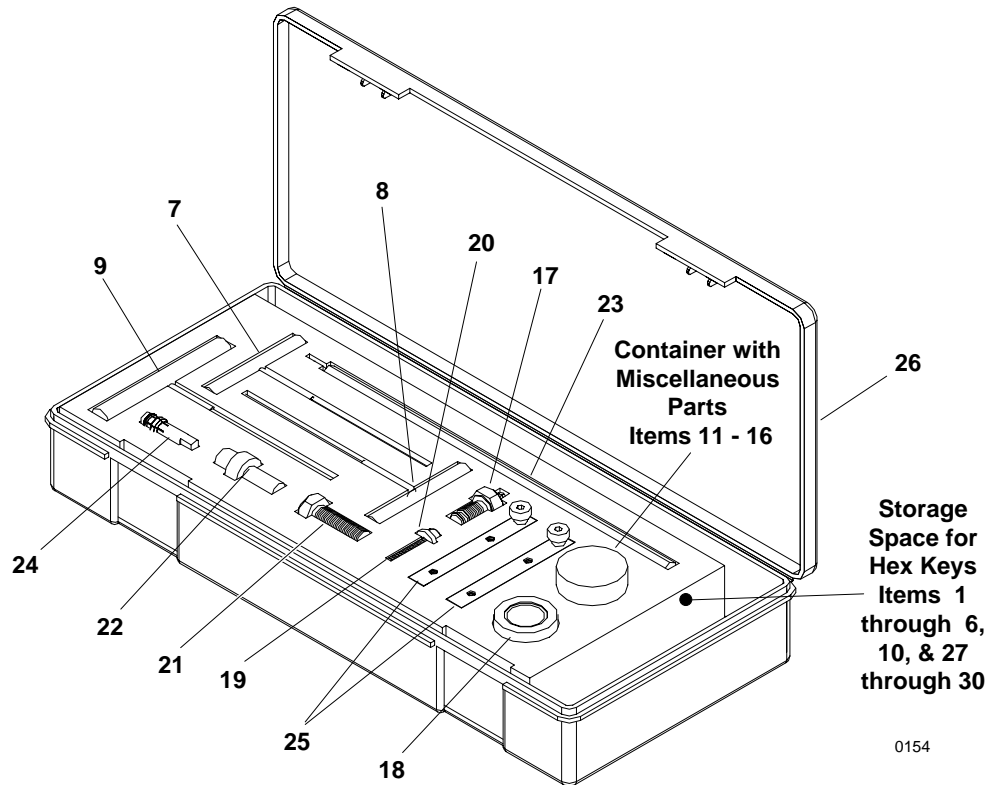

Item	Part No.	Description	Qty.
1	807-562	Hex Key, 2.5 mm Long Arm	2
2	807-563	Hex Key, 3 mm Long Arm	2
3	807-564	Hex Key, 4 mm Long Arm	2
4	807-565	Hex Key, 5 mm Long Arm	2
5	807-566	Hex Key, 6 mm Long Arm	1
6	807-568	Hex Key, 8 mm Long Arm	1
7	807-610	Hex Key, 3 mm T-Handle	1
8	807-609	Hex Key, 4 mm T-Handle	1
9	807-569	Hex Key, 5 mm T-Handle	1
10	807-577	Torx® Key T-25 Short Arm	1
11	200039M	Belt Tracking Cam	2
12	300353MP	Special Flat Head Cap Screw, M4-0.70 x 10 mm	8
13	910506M	Button Head Cap Screw, M5-0.80 x 6 mm	4
14	910510M	Button Head Cap Screw, M5-0.80 x 10 mm	4
15	910612M	Button Head Cap Screw, M6-.1.0 x 12 mm	4

Item	Part No.	Description	Qty.
16	920406M	Socket Head Cap Screw, M4-0.70 x 6 mm	6
17	200046M	Greasing Adapter	1
18	25-09	Retaining Sleeve/Bearing Removal Tool	1
19	920635M	Socket Head Cap Screw, M6-1.0 x 35 mm	1
20	605279	Washer, Special	1
21	906-278	Bolt, Special Threaded	1
22	25-10	Bearing Insertion Tool	1
23	25-08	Hex Key Extension Tool 2" (44 mm) to 12" (610 mm)	1
24	25-05	Bearing Removal Tool	1
25	300362M	Belt Tensioning Tool	2
26	661451	Tool Box 2500M-ENG	1
27	807-518	Hex Key, 1/8" Long Arm	1
28	807-520	Hex Key, 3/16" Long Arm	1
29	807-528	Hex Key, 7/32" Long Arm	1
30	807-521	Hex Key, 1/4" Long Arm	1

Numerical Index

LPZ Cleated Belt Conveyors

Part #	Page	Part #	Page	Part #	Page
200034	29	300106	23	300637M	31, 33
200038M	25, 27, 29	300107	23	300639M	31, 33
200039M	25, 27, 29, 44	300108	23	300640M	31, 33
200046M	44	300109	23	300649	43
200151	29	300110	23	300653M	33
200331M	25, 27, 29	300111	23	300657M	31
200341M	25, 27, 29	300112	23	300658M	25
202809M	24	300139M	27	300660M	25
202819M	24	300146	27	300665M	31
202825M	24	300150M	25, 27, 29, 31, 33	300666M	31
203008M	29	300152M	25, 27, 29, 31, 33	300667M	31
203012M	29	300155M	25, 27, 29	300671M	31
203018M	29	300158M	25, 27, 29	300672M	31
203024M	29	300160P	31	300684	24
207206M	31, 33	300166M	29	300685	24
207208M	31, 33	300167	29	300686	24
207210M	31, 33	300168	29	300687	24
25-05	44	300169M	29	300695M	43
25-09	44	300186M	39, 41	300696M	43
25-10	44	300187	39, 41	300697M	43
25-08	44	300208M	23, 24	300741M	43
300001	23	300212M	23, 24	300743M	43
300002	23	300218M	23, 24	300744M	43
300003	23	300224M	23, 24	300745	43
300004	23	300353MP	22, 31, 33, 44	300746	43
300005	23	300362M	44	300774M	43
300006	23	300420MP	31, 33	300802P	23
300007	23	300421M	31	300803P	23
300008	23	300422M	31	300804P	23
300009	23	300495M	31, 33	300805P	23
300010	23	300496M	33	300806P	23
300011	23	300497M	31, 33	300807P	23
300012	23	300498M	31, 33	300808P	23
300028M	29	300499M	31, 33	300809P	23
300029M	29	300521M	33	300810P	23
300032M	25, 27	300522M	33	300811P	23
300033M	25, 27	300526M	33	300812P	23
300038M	39, 40, 41	300527M	33	300831M	43
300049M	39, 41	300528M	31, 33	300832M	43
300058M	29	300536M	31, 33	300833M	43
300059M	29	300538M	33	300834M	43
300060M	29	300546M	33	300835M	43
300061M	29	300580M	33	300836M	43
300066M	25, 27	300582M	33	300837M	43
300067M	25, 27	300584M	31	300838M	43
300068M	25, 27	300585M	31	300841M	43
300069M	25, 27	300596M	33	300842M	43
300101	23	300597M	33		
300102	23	300635M	31		
300103	23	300636M	31, 33		
300104	23				
300105	23				

LPZ Cleated Belt Conveyors

Numerical Index

Part #	Page	Part #	Page	Part #	Page
300843M	43	301908	29, 31, 33	307318M	27
300844M	43	301912	29, 31, 33	307324M	27
300845M	43	301918	29, 31, 33	310035M	39
300846M	43	301924	29, 31, 33	310039M	40
300847M	43	303018M	25, 27, 29	310041M	40
300848M	43	303024M	25, 27, 29	310042M	40
300849M	25	303308M	23, 24	310045M	41
300859M	43	303312M	23, 24	310046M	39, 41
300860M	43	303318M	23, 24	310047M	40
300861M	43	303324M	23, 24	310048M	40
300951	25	303501	24	315406	31, 33
300952	25	303502	24	315408	31, 33
300953	25	303503	24	315418	31, 33
300954	25	303504	24	326608	29, 31, 33
300955	25	303505	24	326612	29, 31, 33
300956	25	303506	24	326618	29, 31, 33
300975M	31	303507	24	326624	29, 31, 33
300976M	31	303508	24	326708	31, 33
300977M	33	303509	24	326712	31, 33
300978M	33	303510	24	326718	31, 33
301002P	23	303511	24	326724	31, 33
301003P	23	303512	24	32M005PS411F (R or N)	42
301004P	23	303601	24	32M010PS411F (R or N)	42
301005P	23	303602	24	32M010PS423FN	42
301006P	23	303603	24	32M020PS411F (R or N)	42
301007P	23	303604	24	32M020PS423FN	42
301008P	23	303605	24	32M030PS411F (R or N)	42
301009P	23	303606	24	32M030PS423FN	42
301010P	23	303607	24	382014	34, 35, 36, 37
301011P	23	303608	24	382015	34, 35, 36, 37
301012P	23	303609	24	382016	34, 35, 36, 37
301201P	23	303610	24	382017	34, 35, 36, 37
301202P	23	303611	24	382018	34, 35, 38
301203P	23	303612	24	382019	34, 35, 38
301204P	23	305208M	31, 33	382020	34, 35, 38
301205P	23	305212M	31, 33	382021	34, 35, 38
301206P	23	305218M	31, 33	382034	36, 37, 38
301207P	23	305224M	31, 33	382035	36, 37, 38
301208P	23	305581M	33	382036	38
301209P	23	305583M	33	382037	38
301210P	23	306708	29	382038	36, 37, 38
301211P	23	306712	29	382039	36, 37, 38
301212P	23	306718	29	382040	34, 35
301308	27	306724	29	382041	34, 35
301312	25, 27	307201	22	382054	36, 37
301318M	25, 27	307208M	23	382055	36, 37
301324M	25, 27	307210M	23	382056	38
301708	29	307212M	23	382057	38
301712	29	307308M	27		
301718M	29	307312M	27		
301724M	29				

Numerical Index

LPZ Cleated Belt Conveyors

Part #	Page	Part #	Page	Part #	Page
382058	35	639971M	43	910410M	39, 41
382059	35	661451	44	910506M	25, 27, 29, 44
382060	36, 37	802-059	39, 41	910508M	27
382061	36, 37	802-073	31	910510M	25, 31, 40, 44
382074	34, 35, 36, 37, 38	802-110	29, 31, 33	910516M	22, 24, 31, 33
382075	34, 35, 36, 37, 38	807-521	44	910525M	22
382076	34, 35, 36, 37, 38	807-562	44	910612M	25, 27, 29, 31, 33, 44
382077	34, 35, 36, 37, 38	807-563	44	910620M	31, 33
382078	34, 35, 36, 37, 38	807-564	44	915-051	29, 31, 33
382096	35	807-565	44	920406M	44
382097	35	807-566	44	920508M	29
382098	35	807-568	44	920518M	40
382099	35	807-569	44	920520M	40
382138	38	807-577	44	920614M	31, 33
382139	38	807-609	44	920616M	39, 41, 43
382156	38	807-610	44	920620M	39, 40, 41
382157	38	807-384	25, 27, 29	920625M	39, 40, 41, 43
382158	34	807-518	44	920630M	39, 41
382159	34	807-520	44	920635M	40, 44
605279	44	807-528	44	920650M	25, 27, 29
605284	39, 41	807-584	40	921250M	39, 41
62M010PSD3DEN	42	807-856	25	930508M	43
62M020PSD3DEN	42	811-126	39, 41	930510M	43
62M030PSD3DEN	42	811-127	39, 41	930512M	25, 27, 29, 31, 33
62M060PS411F (R or N)	42	811-133	39, 41	930516M	43
62M060PS423FN	42	811-135	39, 41	930518M	40
62M060PSD3DEN	42	811-136	39, 41	930525M	22, 24
62M180PS411F (R or N)	42	811-137	39, 41	930612M	25, 27, 29
62M180PSD3DEN	42	811-204	39, 41	930625M	39, 41
62MD1134	42	811-205	39, 41	969900M	33
62MD1134R	42	811-206	39, 41	970606M	41
625619	15	814-059	39, 41	970608M	39
628144M	39, 41	814-060	39, 41	980018M	39, 40, 41, 42
		906-278	44		
		910408M	43		

RETURN POLICY

No returns will be accepted without prior written factory authorization. When calling for authorization, please have the following information ready for the Dorner Factory representative or your local distributor:

1. Name and address of customer.
2. Item(s) being returned.
3. Reason for return.
4. Customer's original order number used when ordering the item(s).
5. Dorner or distributor invoice number.

A representative will discuss action to be taken on the Returned items and provide a Returned Goods Authorization Number to reference.

There will be a 15% restocking charge on all new items returned for credit where Dorner was not at fault. These will not be accepted after 60 days from original invoice date. The restocking charge covers inspection, cleaning, disassembly, and reissuing to inventory.

If a replacement is needed prior to evaluation of returned item, a purchase order must be issued. Credit (if any) is issued only after return and evaluation is complete.

- Dorner has representatives throughout the world. Feel free to contact Dorner for the name of your local representative. Our technical sales and service staff will gladly help with your questions on Dorner products.

**For replacement parts, contact an authorized
Dorner Service Center or the factory.**

DORNER[®]

Dorner Mfg. Corp. reserves the right to change or discontinue products without notice. All products and services are covered in accordance with our standard warranty. All rights reserved. ©Dorner Mfg. Corp. 1999

DORNER MFG. CORP.

580 Industrial Drive, PO Box 20
Hartland, WI 53029-0020 USA

USA

TEL 1-800-397-8664 (USA)

FAX 1-800-369-2440 (USA)

Outside the USA:

TEL 1-414-367-7600, FAX 1-414-367-5827

DORNER

Arnold-Sommerfeld-Ring 2
D-52499 Baesweiler

Germany

TEL (02401) 80 52 90

FAX (02401) 80 52 93

Internet: www.dorner.com