

### 2100/3100 Series or LPZ Conveyor Mounting

Mount the motor starter to the conveyor T-slot as shown (Figure 1 or 2).

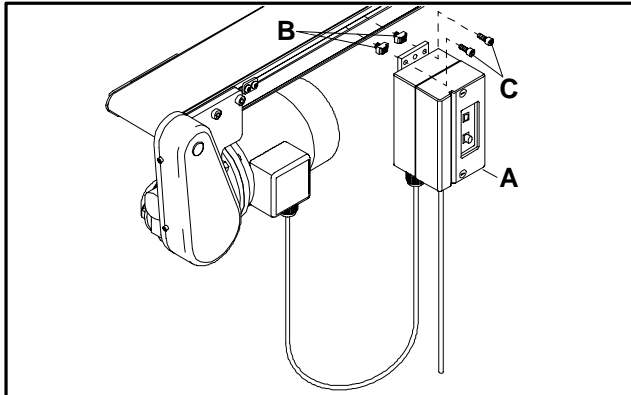

Figure 1

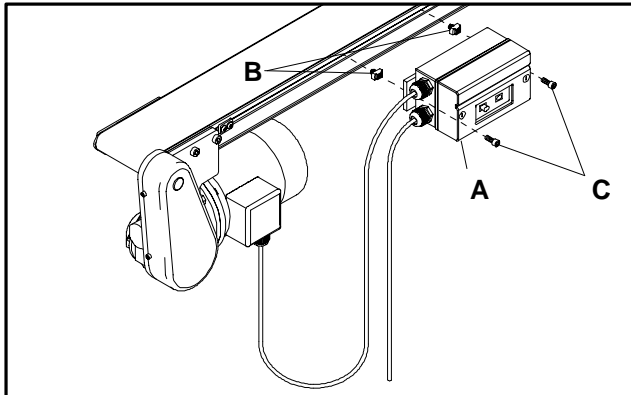

Figure 2

### 6100 Series Conveyor Mounting

Mount the motor starter to the bottom edge of the conveyor as shown (Figure 3 or 4).

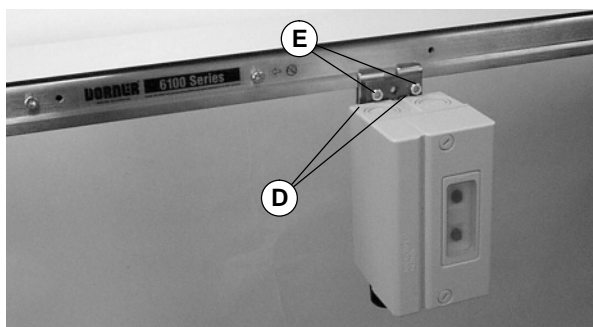

Figure 3

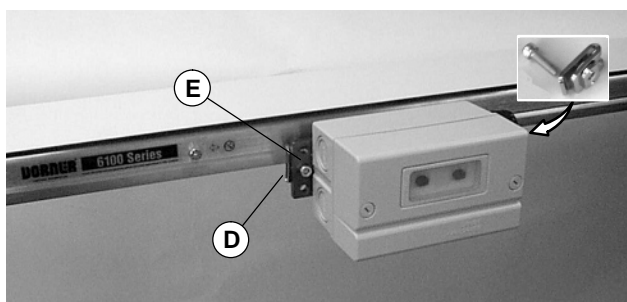

Figure 4

### Illustration References

- A Motor Starter
- B (2) M6 T-Slot Spring Nuts
- C Box Mounting Screws, (2) M6 x 16 mm Socket Head
- D (2) 6100 Series Accessory Mounting Clips (450186M)
- E Clip Mounting Screws, (2) M6 x 20 Socket Head
- F (2) M6 Steel Stand Spring Nuts

### Conveyor Stand Mounting

Attach the motor starter to the aluminum stand leg or single post support stand using the two (2) smaller M6 spring nuts (B) as shown (Figure 5). The starter may be attached to the steel stand leg using the two (2) larger M6 spring nuts (F) as shown (Figure 6).

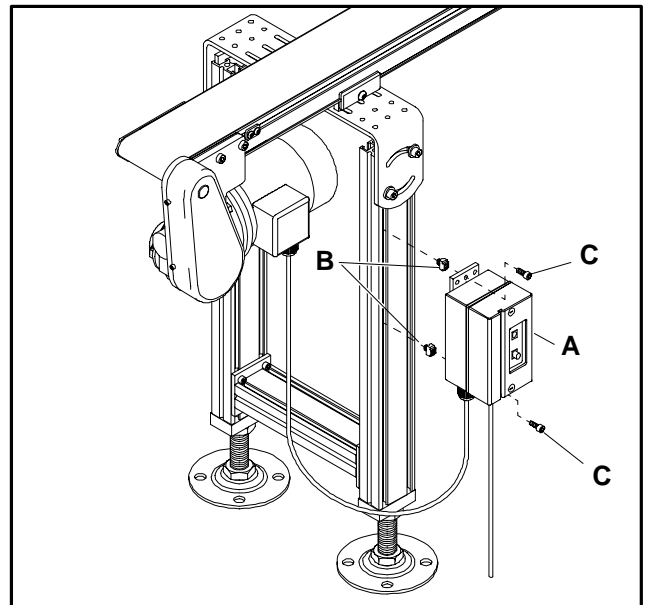

Figure 5

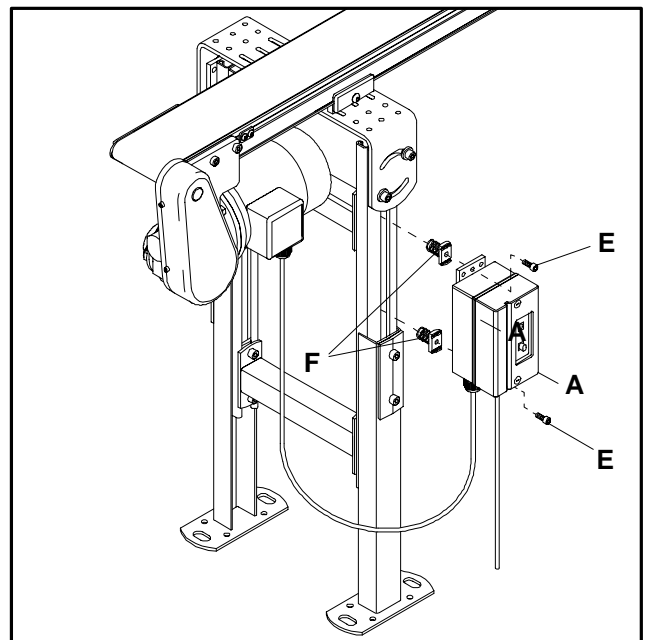

Figure 6

<continued on next page>

# Manual Motor Starter Mounting & Wiring

**NOTE:** The mounting hole center-line to center-line dimensions (Figure 7) are provided for control panel mounting.

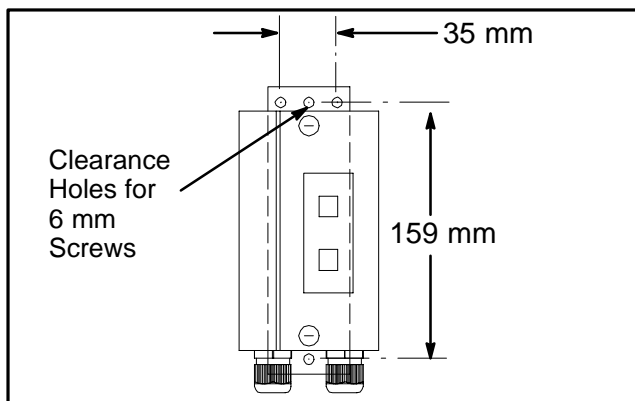

Figure 7

## Wiring

**WARNING**

To prevent injury, make sure all electrical power sources have been disconnected before you perform any maintenance or adjustments or replace any components.

The 230 and the 400 volts three-phase manual motor starters must be wired, in accordance with applicable local electrical codes. The proper three-phase motor shaft rotation is achieved when the line phase sequence L1, L2 & L3 is connected to the terminals as shown in Figure 8.

Attach the ground wire to the lower left terminal marked  $\perp$ .

**NOTE:** The motor ground wire will also be attached to this same lower left terminal marked  $\perp$ .

**WARNING**

To prevent injury from electrocution, make sure this ground connection is solidly made and continuity-tested, before any electrical power is first applied.

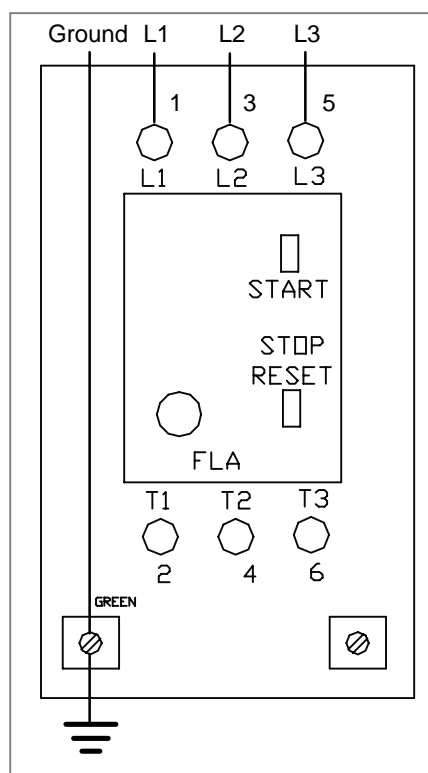

Figure 8

<p><b>DORNER</b><sup>®</sup></p> <p>Dorner Mfg. Corp. reserves the right to change or discontinue products without notice. All products and services are covered in accordance with our standard warranty. All rights reserved. ©Dorner Mfg. Corp. 1999</p>	<p><b>DORNER MFG. CORP.</b> 580 Industrial Drive, PO Box 20 Hartland, WI 53029-0020 USA USA TEL 1-800-397-8664 (USA) FAX 1-800-369-2440 (USA) Outside the USA: TEL 1-414-367-7600, FAX 1-414-367-5827</p>	<p><b>DORNER</b> Arnold-Sommerfeld-Ring 2 D-52499 Baesweiler Germany TEL (02401) 80 52 90 FAX (02401) 80 52 93</p>
---	---	--