

# Accessory Assembly Instructions

## 2100 Series Light Duty End Stop Kits (215502M through 215524M)

! **WARNING** !

**To prevent injury, make sure all electrical and pneumatic power sources have been disconnected and locked-out, before you perform any assembly or adjustments. To prevent injury, keep hands and fingers away from the end stop while the conveyor is running. Because Dorner Mfg. Corp. cannot control the physical installation and application of conveyors, taking protective measures in the responsibility of the user.**

### NOTE:

For shipping, end stop (D) is attached to stop plate (B) or plates (B & F) with stop nut bar(s) (C) anchored with the two (or four) M6 x 12 mm button head screws (A). Detach all of the screws before proceeding. In addition, refer to the 2100 Series manual, furnished with your conveyor, and release conveyor belt tension. In addition, installing an end stop kit on a conveyor equipped with bolt-on guiding may require modifying the guides on both sides of the conveyor, in the areas of the tail plates, to provide additional clearance for attaching the end stop.

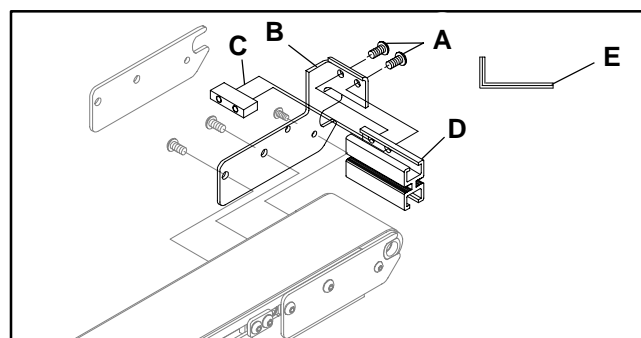

Item	Qty.	Description
A	2	M6 x 12 mm Button Head Screw (910612M)
B	1	End Stop Plate RH (677741M)
C	1	End Stop Nut Bar (677742M)
D	1	End Stop 2" (44 mm) (677717) or End Stop 3" (70 mm) (677718)
E	1	4 mm Hex Key Wrench (807-564)

**Figure 1: Light Duty End Stop Kit Components for 2" (44 mm) or 3" (70 mm) Conveyors**

The conveyor light duty end stop kits are pre-packaged assemblies that vary by conveyor model and by the width of the conveyors.

### Installation

The 2100 Series kits, for 2" (44 mm) (215502M) or 3" (70 mm) (215503M) wide conveyors, include the parts and metric mounting hardware shown in Figure 1. The 2100 Series kits, for 4" (95 mm) through 24" (610 mm) (215504M through 215524M) wide conveyors, include the parts and metric mounting hardware shown in Figure 6.

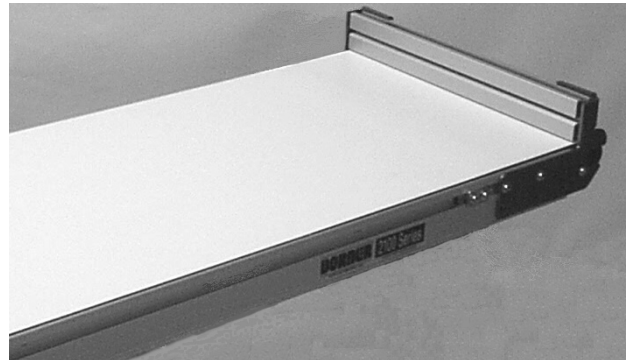

#### Procedure for 2" (44 mm) or 3" (70 mm) Conveyors

1. Verify all kit parts are present.
2. Release conveyor belt tension following procedures outlined in the 2100 Series manual furnished with your conveyor.
3. On the right side of the conveyor, remove and retain the three screws securing the existing tail plate to the conveyor (shown in phantom in Figure 1).
4. Position and secure the new end stop tail plate using the original hardware (Figure 2).

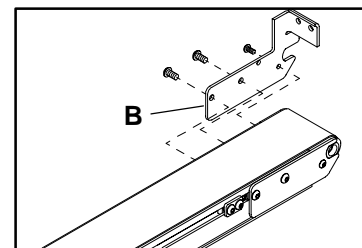

**Figure 2: 2" (44 mm) or 3" (70 mm) Conveyor End Stop Plate Installation Detail**

5. Refer to Figure 3 and place the end stop nut bar (C) into the slot of the end stop (D) and align the mounting holes in the two components.

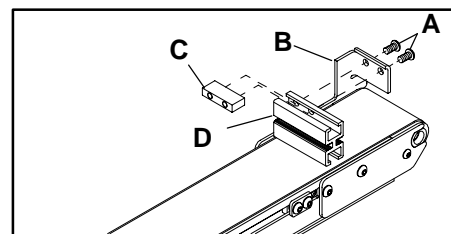

**Figure 3: 2" (44 mm) or 3" (70 mm) End Stop and End Stop Nut Bar Installation Detail**

6. Refer to Figure 3 and secure the end stop to the end stop plate with the two M6 x 12 mm button head screws (A). Tightly secure the screws with the 4 mm hex key wrench (E) provided.

# Accessory Assembly Instructions

7. Re-tension conveyor belt and re-check conveyor belt tracking following appropriate procedures outlined in the 2100 Series manual furnished with your conveyor.

## Procedure for 4" (95 mm) – 24" (610 mm) Conveyors

1. Release conveyor belt tension following procedures outlined in the 2100 Series manual furnished with your conveyor.
2. On both side of the conveyor, remove and retain the three screws securing the existing right and left hand tail plates (shown in phantom in Figure 6) to the Conveyor.
3. Position and secure the new end stop tail plate RH (B) and end stop tail plate LH (F) using the original hardware (Figure 4).

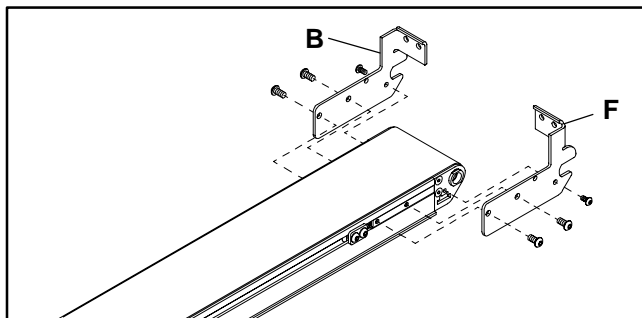

**Figure 4: 4" (95 mm) through 24" (610 mm) Conveyor End Stop Plate Installation Detail**

4. Refer to Figure 5 and place the end stop nut bars (C) into the slot on each side of the end stop (D) and align the mounting holes in the end stop nut bars and end stop.
5. Refer to Figure 5 and secure the end stop to each end stop plate with the two M6 x 12 mm button head screws (A). Tightly secure the screws with the 4 mm hex key wrench (E) provided.

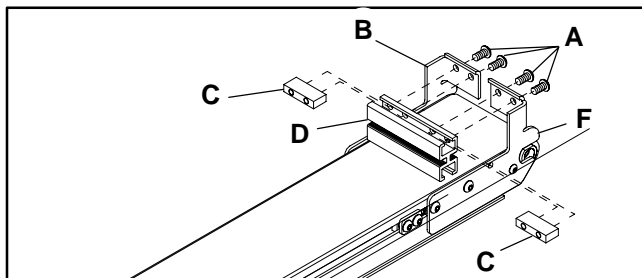

**Figure 5: 2" (44 mm) or 3" (70 mm) End Stop and End Stop Nut Bar Installation Detail**

6. Re-tension the conveyor belt and re-check conveyor belt tracking following appropriate procedures outlined in the 2100 Series manual furnished with your conveyor.

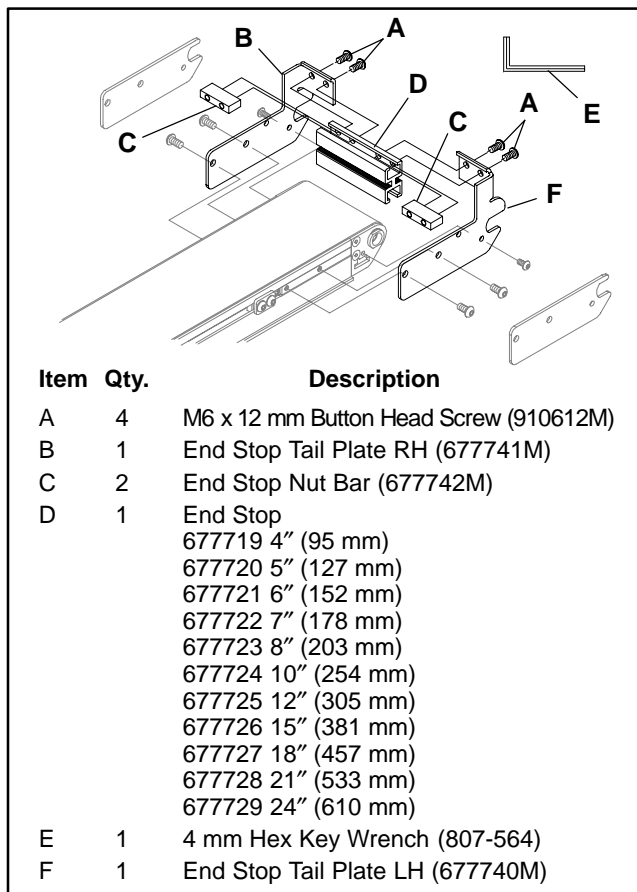

**Figure 6: Light Duty End Stop Kit Components for 4" (95 mm) through 24" (610 mm) Conveyors**

Install the guide retaining clips next to the end of each end stop plate in the same manner as other clips already on the conveyor. Tightly secure the screws with the 4 mm hex key wrench (K) provided.

# DORNER<sup>®</sup>

Dorner Mfg. Corp. reserves the right to change or discontinue products without notice. All products and services are covered in accordance with our standard warranty. All rights reserved. © Dorner Mfg. Corp. 1998

## DORNER MFG. CORP.

580 Industrial Drive, PO Box 20  
Hartland, WI 53029-0020 USA

USA

TEL 1-800-397-8664 (USA)

FAX 1-800-369-2440 (USA)

Outside the USA:

TEL 1-414-367-7600, FAX 1-414-367-5827

## DORNER

Arnold-Sommerfeld-Ring 2  
D-52499 Baesweiler

Germany

TEL (02401) 80 52 90

FAX (02401) 80 52 93