



# 7350 and 7360 Series Bottom Mount Parallel Shaft Drive Package

Installation, Maintenance & Parts Manual



US and CE Versions

DORNER MFG. CORP.  
P.O. Box 20 • 975 Cottonwood Ave.  
Hartland, WI 53029-0020 USA

INSIDE THE USA  
TEL: 1-800-397-8664  
FAX: 1-800-369-2440

OUTSIDE THE USA  
TEL: 262-367-7600  
FAX: 262-367-5827

For other service manuals visit our website at:  
[www.dorner.com/service\\_manuals.asp](http://www.dorner.com/service_manuals.asp)

# Table of Contents

Introduction .....	2	Required Tools .....	7
Warnings - General Safety .....	3	Bottom Mount Parallel Shaft Drive Package .....	7
Product Description .....	4	Preventive Maintenance and Adjustment .....	10
Specifications .....	4	Required Tools .....	10
Gearmotor Mounting Package Models: .....	4	Timing Belt Tensioning.....	10
Table 1: Gearmotor Specifications .....	5	Timing Belt Replacement.....	11
US Version .....	5	Drive or Driven Pulley Replacement .....	12
CE Version .....	5	Motor Replacement .....	12
Table 2: Fixed Speed Gearmotors .....	5	Service Parts.....	14
US Version .....	5	Bottom Mount Parallel Drive Package.....	14
CE Version .....	5	Parallel Shaft Gearmotors .....	15
Table 3: Variable Speed Gearmotors.....	6	US Version.....	15
US Version .....	6	CE Version.....	15
CE Version .....	6	Return Policy.....	16
Installation .....	7		

## Introduction

### IMPORTANT

*Some illustrations may show guards removed. DO NOT operate equipment without guards.*

Upon receipt of shipment:

- Compare shipment with packing slip. Contact factory regarding discrepancies.
- Inspect packages for shipping damage. Contact carrier regarding damage.
- Accessories may be shipped loose. See accessory instructions for installation.

Dorner's Limited Warranty applies.

Dorner reserves the right to make changes at any time without notice or obligation.

Dorner has convenient, pre-configured kits of Key Service Parts for all conveyor products. These time saving kits are easy to order, designed for fast installation, and guarantee you will have what you need when you need it. Key Parts and Kits are marked in the Service Parts section of this manual with the Performance Parts Kits  logo.

# Warnings - General Safety

## WARNING

The safety alert symbol, black triangle with white exclamation, is used to alert you to potential personal injury hazards.

## DANGER



Climbing, sitting, walking or riding on conveyor will cause severe injury.  
**KEEP OFF CONVEYORS.**

## DANGER



**DO NOT OPERATE CONVEYORS IN AN EXPLOSIVE ENVIRONMENT.**

## WARNING



Exposed moving parts can cause severe injury.  
**LOCK OUT POWER** before removing guards or performing maintenance.

## WARNING



Gearmotors may be **HOT**.  
**DO NOT TOUCH** Gearmotors.

## WARNING



Exposed moving parts can cause severe injury.  
**REPLACE ALL GUARDS BEFORE RUNNING CONVEYOR.**

## WARNING



Dorner cannot control the physical installation and application of conveyors. Taking protective measures is the responsibility of the user.  
When conveyors are used in conjunction with other equipment or as part of a multiple conveyor system, **CHECK FOR POTENTIAL PINCH POINTS** and other mechanical hazards before system start-up.

# Product Description

Refer to **(Figure 1)** for typical components.

1	Conveyor
2	Cover
3	Driven Pulley
4	Timing Belt
5	Drive Pulley
6	Gearmotor
7	Timing Belt Tensioner
8	Mounting Bracket

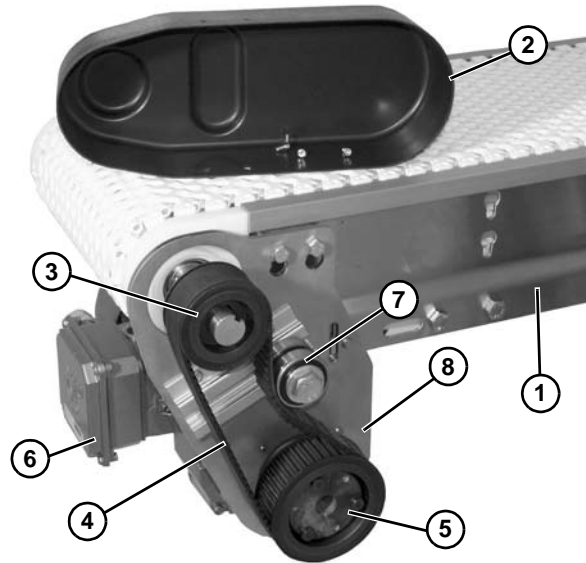

**Figure 1**

# Specifications

## Gearmotor Mounting Package Models:

735 M B 2 S A 28 28

- 735 — Language
- M — US Version
- U — CE English Version
- B — Drive Type
- 2 — Gearmotor Type
- S — Gearmotor Size
- A — Drive Position
- 28 — Gearmotor Sprocket
- 28 — Conveyor Sprocket

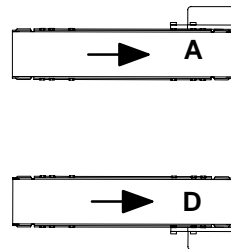

# Specifications

## Table 1: Gearmotor Specifications

### US Version

Item	Fixed Speed	Variable Speed
Output Power	0.16 hp (0.12 kW), 0.25 hp (0.19 kW), 0.50 hp (0.37 kW), 0.75 hp (0.56 kW), 1.00 hp (0.75 kW)	
Input Voltage	230 / 460 V.A.C. 3 Phase	
Input Frequency	60 Hz	6 - 60 Hz
Gearmotor Ratios	6:1, 8:1, 10:1, 13:1, 20:1, 34:1, 54:1, 81:1	
Motor Type	Totally Enclosed, Fan Cooled	

### CE Version

	Fixed Speed	Variable Speed
Output Power	0.16kW to 1.12 kW	
Input Power	230 / 400 V 3 Phase	
Input Frequency	50 Hz	12 - 80 Hz
Gearmotor Ratios	81:1, 39:1, 29:1, 19:1, 16:1, 11:1, 9:1, 7:1	
Motor Type	Totally Enclosed, Fan Cooled	

## Table 2: Fixed Speed Gearmotors

### US Version

Part Number	Belt Speed		RPM	HP	kW	Volts	Phase	FLA	in-lbs	N-m
	Ft/min	M/min								
74M081PS423FN	21	6.4	21	0.16	0.12	230/460	3	.88 / .44	483	55
74M054PS423FN	31	9.4	31	0.25	0.19	230/460	3	1.12 / 0.56	507	57
74M034PS423FN	50	15.2	50	0.50	0.37	230/460	3	1.90 / 0.95	633	72
74M020PS423FN	84	25.6	84	0.75	0.56	230/460	3	2.70 / 1.35	563	64
74M013PS423FN	122	37.2	122	1.00	0.75	230/460	3	3.66 / 1.83	517	58
74M010PS423FN	170	51.8	170	1.00	0.75	230/460	3	3.66 / 1.83	374	42
74M008PS423FN	190	57.9	190	1.00	0.75	230/460	3	3.66 / 1.83	333	38
74M006PS423FN	258	78.6	258	1.00	0.75	230/460	3	3.66 / 1.83	246	28

### CE Version

Part Number	Belt Speed		RPM	kW	Volts	Phase	FLA		N-m
	Ft/min	M/min					at 230V	at 400V	
73U081PS423FN	17	5.2	17	0.12	230/400	3	0.96	0.55	44
73U039PS423FN	36	11.0	36	0.37	230/400	3	1.90	1.09	62
73U029PS423FN	48	14.6	48	0.56	230/400	3	2.64	1.52	70
73U019PS423FN	74	22.6	74	0.75	230/400	3	3.65	2.1	60
73U016PS423FN	88	26.8	88	0.75	230/400	3	3.65	2.1	51
73U011PS423FN	127	38.7	127	1.12	230/400	3	4.89	2.81	53
73U009PS423FN	158	48.2	158	1.12	230/400	3	4.89	2.81	42
73U007PS423FN	194	59.1	194	0.75	230/400	3	3.65	2.1	37

# Specifications

**Table 3: Variable Speed Gearmotors**

## US Version

Part Number	Belt Speed		RPM		HP	kW	Volts	FLA	in-lbs	N-m
	Ft/min	M/min	Min	Max						
74M081PS423EN	21	6.4	4.2	21	0.16	0.12	230	.88	483	55
74M054PS423EN	31	9.4	6.2	31	0.25	0.19	230	1.12	507	57
74M034PS423EN	50	15.2	10	50	0.50	0.37	230	1.90	633	72
74M020PS423EN	84	25.6	16.8	84	0.75	0.56	230	2.70	563	64
74M013PS423EN	122	37.2	24.4	122	1.00	0.75	230	3.66	517	58
74M010PS423EN	170	51.8	34	170	1.00	0.75	230	3.66	374	42
74M008PS423EN	190	57.9	38	190	1.00	0.75	230	3.66	333	38
74M006PS423EN	258	78.6	51.6	258	1.00	0.75	230	3.66	246	28

## CE Version

Part Number	Belt Speed (Ft/min)		Belt Speed (M/min)		RPM		Kw	Volts	Phase	FLA		N-m
	Min	Max	Min	Max	Min	Max				at 230V	at 400V	
73U081PS423EN	4.1	27.2	2.6	5.2	4	27	0.12	230/400	3	0.96	0.55	44
73U039PS423EN	8.6	57.6	5.5	11.0	9	58	0.37	230/400	3	1.90	1.09	62
73U029PS423EN	11.5	76.8	7.3	14.6	12	77	0.56	230/400	3	2.64	1.52	70
73U019PS423EN	17.8	118.4	11.3	22.6	18	118	0.75	230/400	3	3.65	2.1	60
73U016PS423EN	21.1	140.8	13.4	26.8	21	141	0.75	230/400	3	3.65	2.1	51
73U011PS423EN	30.5	203.2	19.4	38.7	30	203	1.12	230/400	3	4.89	2.81	53
73U009PS423EN	37.9	252.8	24.1	48.2	38	253	1.12	230/400	3	4.89	2.81	42

### NOTE

*For belt speed other than those listed, contact factory for details.*

## Required Tools

- 5/16" wrench
- 4 mm wrench
- 13 mm wrench
- 14 mm wrench
- Large flat head screwdriver
- Torque wrench

## Bottom Mount Parallel Shaft Drive Package

<b>⚠ WARNING</b>

<p><b>SEVERE HAZARD!</b>  <b>LOCK OUT POWER</b> before removing guards or performing maintenance. Exposed moving parts can cause serious injury.</p>

Typical components (Figure 2).

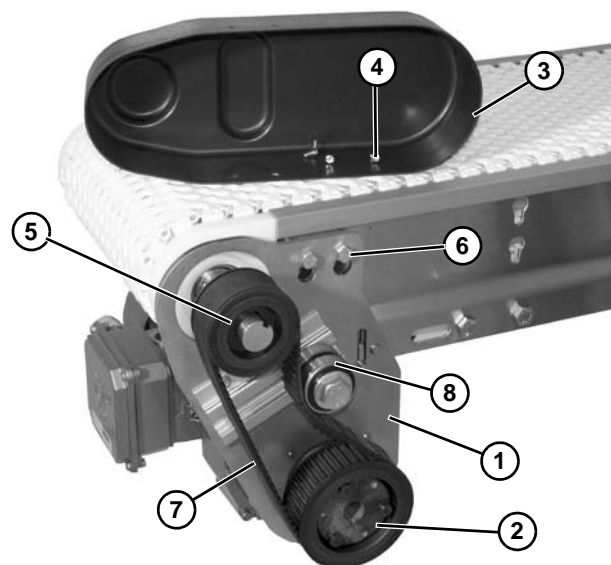
1	Bottom Mount Assembly
2	Drive Pulley
3	Cover
4	M4 Hex Head Screws (4x)
5	Driven Pulley
6	M8 x 35 mm Hex Head Screws (2x)
7	Timing Belt
8	Tensioner



**Figure 2**

1. Locate drive output shaft (Figure 3, item 1). Remove top two existing bolts securing headplate (Figure 3, item 2) to conveyor frame.

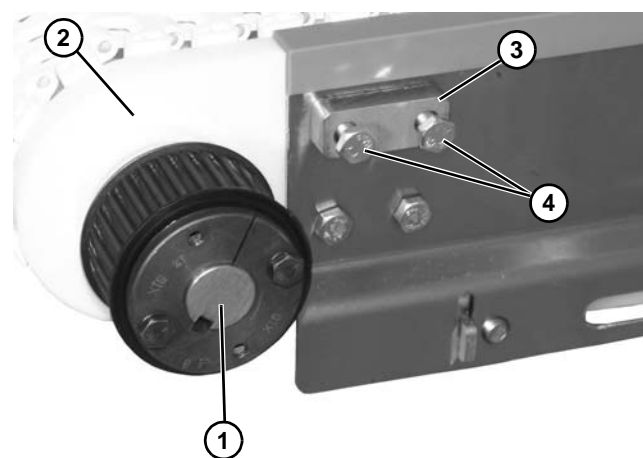

**Figure 3**

2. Install spacer (Figure 3, item 3) and two longer bolts provided (Figure 3, item 4) into conveyor frame and headplate. Leave bolts loose with enough space to slide on mounting assembly.

# Installation

3. Attach bottom mount assembly (Figure 4, item 1) with the two bolts (Figure 4, item 2).

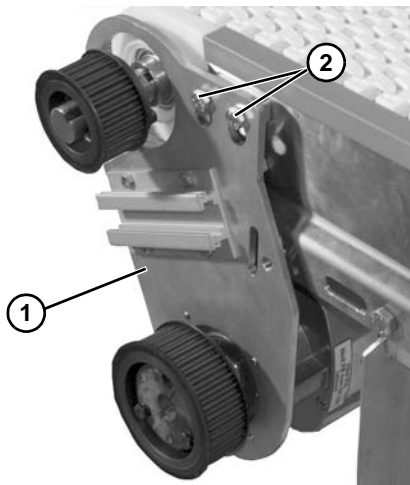

Figure 4

4. Insert bolt (Figure 5, item 1) through backside of conveyor into threaded hole in mounting bracket (Figure 5, item 2).

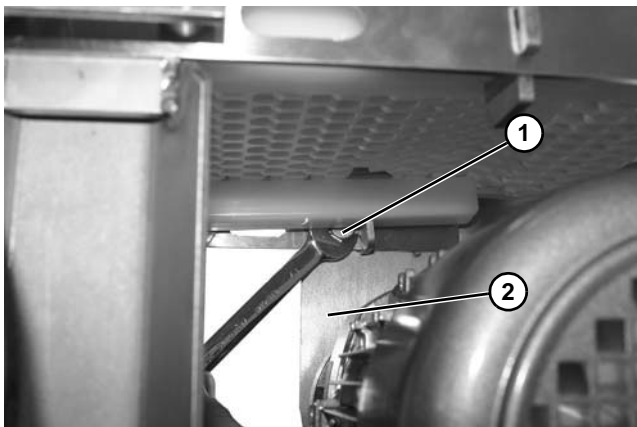

Figure 5

## ⚠ WARNING



Drive shaft keyway may be sharp.  
HANDLE WITH CARE.

5. Install key (Figure 6, item 1).

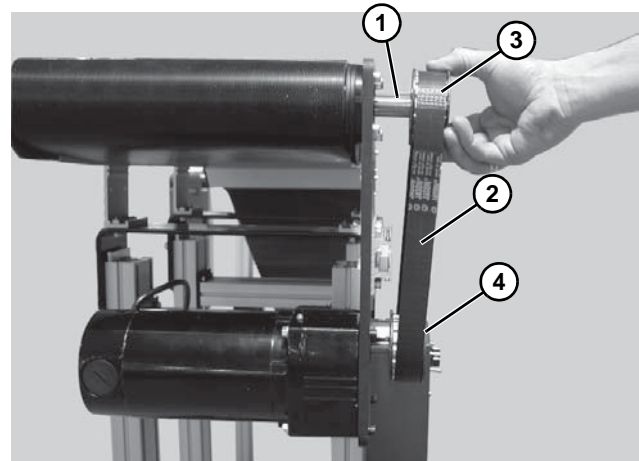

Figure 6

6. Wrap timing belt (Figure 6, item 2) around driven pulley (Figure 6, item 3) and drive pulley (Figure 6, item 4). Install driven pulley onto conveyor shaft.
7. Using a straight edge (Figure 7, item 1), align driven pulley (Figure 7, item 2) with drive pulley (Figure 7, item 3).

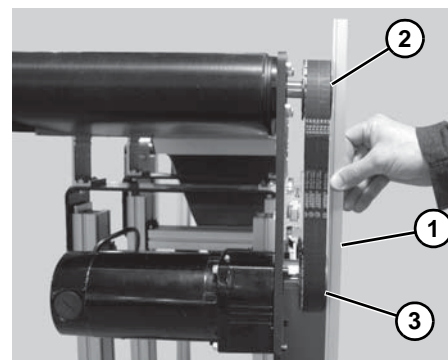

Figure 7

8. Tighten driven pulley taper-lock screws (Figure 8, item 1).

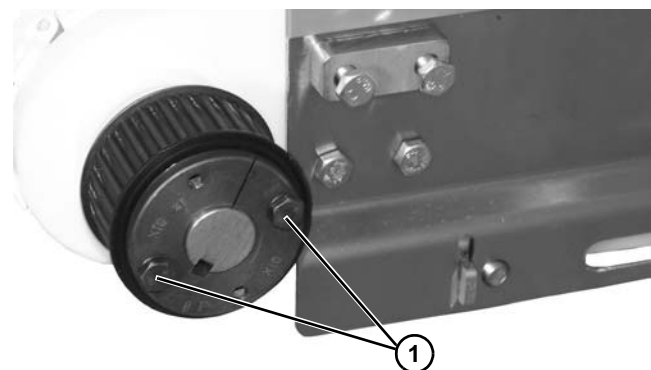
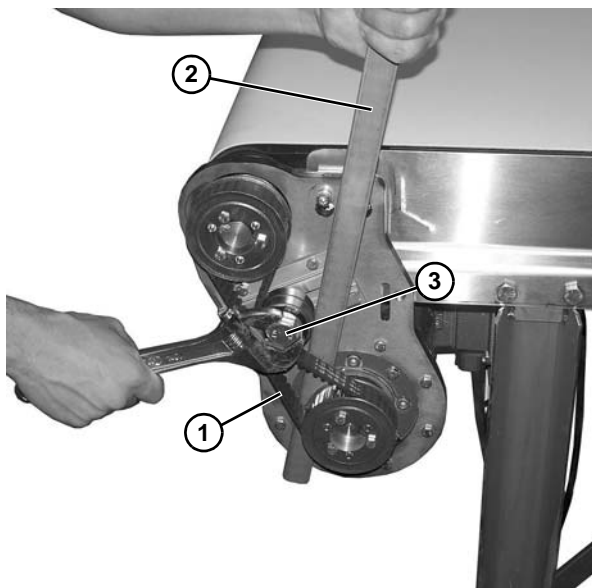

Figure 8



9. Tension timing belt (**Figure 9, item 1**) sufficiently to prevent belt skipping. A pry bar (**Figure 9, item 2**), may be used, as shown, to assist in belt tensioning.



**Figure 9**

10. Tighten tensioner screw (**Figure 9, item 3**) to secure position.

**⚠ CAUTION**

**Over tightening of timing belt will result in reduced gearmotor and timing belt life.**

11. Install cover (**Figure 10, item 1**) with four (4) screws (**Figure 10, item 2**). Tighten screws to 35 in-lb (4 Nm).

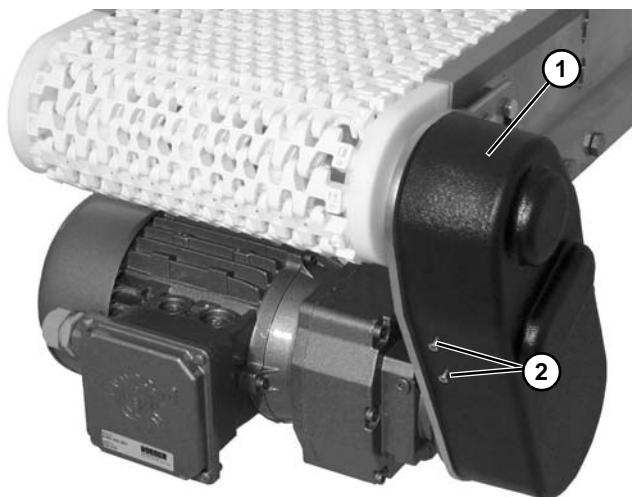

**Figure 10**

# Preventive Maintenance and Adjustment

## Required Tools

- 5/16" wrench
- 4 mm wrench
- 13 mm wrench
- 14 mm wrench
- Large flat head screwdriver
- Torque wrench

## Timing Belt Tensioning

<b>⚠ WARNING</b>

<p>Exposed moving parts can cause severe injury. <b>LOCK OUT POWER</b> before removing guards or performing maintenance.</p>

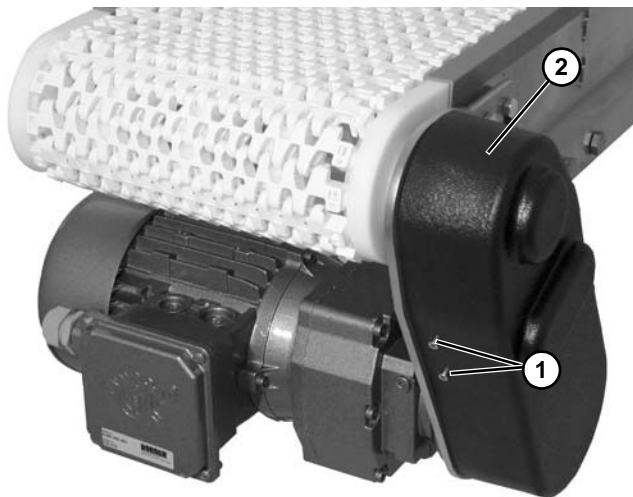
1. Remove four screws (**Figure 11, item 1**) and remove cover (**Figure 11, item 2**).

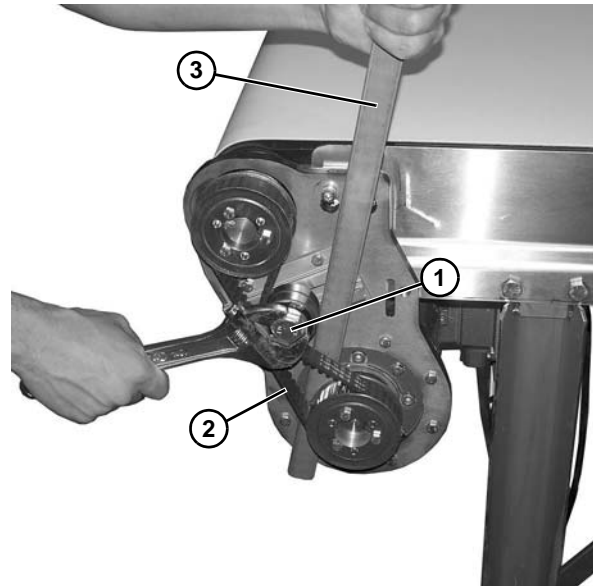

**Figure 11**

2. Loosen tensioner screw (**Figure 12, item 1**).



**Figure 12**

3. Tension timing belt (**Figure 12, item 2**) sufficiently to prevent belt skipping. A pry bar (**Figure 12, item 3**), may be used, as shown, to assist in belt tensioning.
4. Tighten tensioner screw (**Figure 12, item 1**) to secure position.

<b>⚠ CAUTION</b>
<p>Over tightening of timing belt will result in reduced gearmotor and timing belt life.</p>

5. Install cover (**Figure 11, item 2**) with four screws (**Figure 11, item 1**).

# Preventive Maintenance and Adjustment

## Timing Belt Replacement

### ⚠ WARNING



Exposed moving parts can cause severe injury.  
**LOCK OUT POWER** before removing guards or performing maintenance.

1. Remove four screws (Figure 13, item 1) and remove cover (Figure 13, item 2).

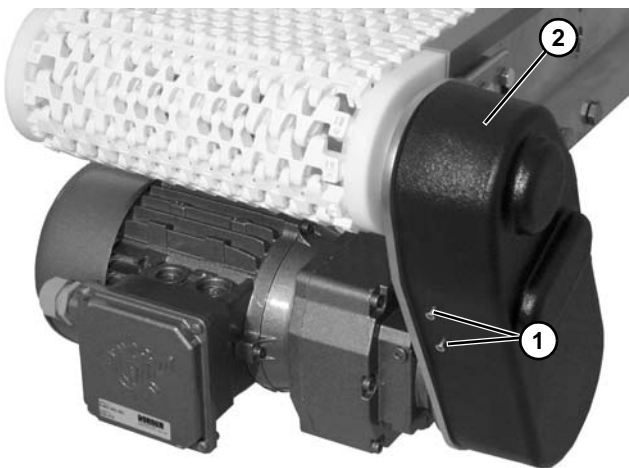

Figure 13

2. Loosen tensioner screw (Figure 14, item 1).

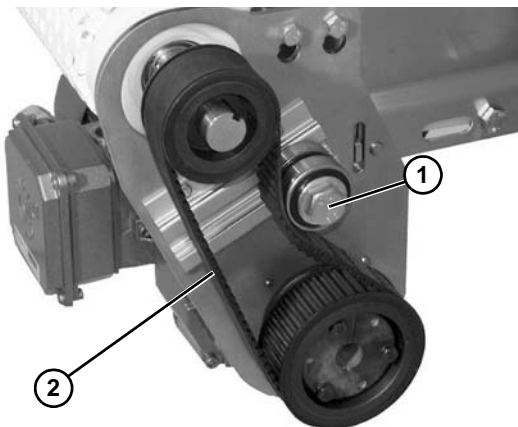

Figure 14

3. Remove timing belt (Figure 15, item 1).

### NOTE

If timing belt does not slide over pulley flange, loosen driven pulley taper-lock screws (Figure 15, item 2) and remove pulley with belt (Figure 15, item 1). For re-installation, see steps 7 thru 9 beginning on page 8.

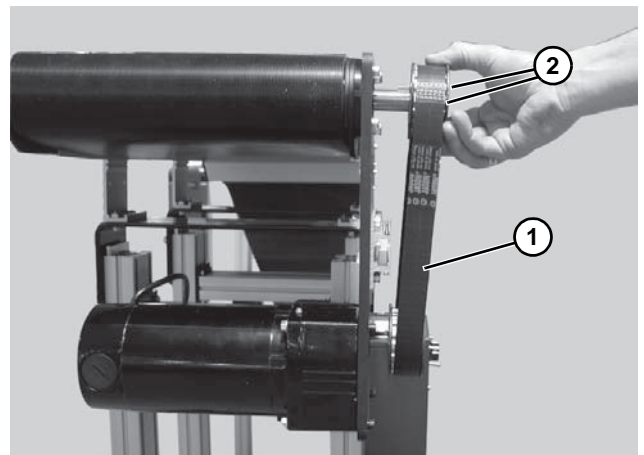

Figure 15

4. Install new timing belt.
5. Tension timing belt (Figure 16, item 1) sufficiently to prevent belt skipping. A pry bar (Figure 16, item 2), may be used, as shown, to assist in belt tensioning.

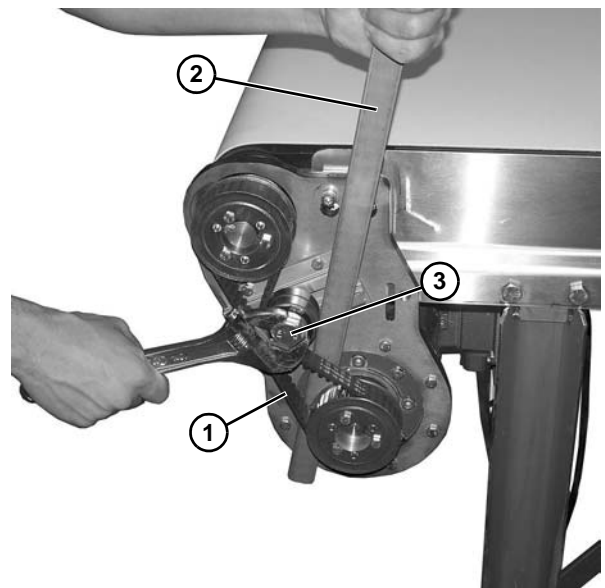

Figure 16

6. Tighten tensioner screw (Figure 16, item 3) to secure position.

# Preventive Maintenance and Adjustment

## ⚠ CAUTION

Over tightening of timing belt will result in reduced gearmotor and timing belt life.

7. Install cover (Figure 17, item 1) with four screws (Figure 17, item 2). Tighten screws to 35 in-lb (4 Nm).



Figure 17

## Drive or Driven Pulley Replacement

### ⚠ WARNING



Exposed moving parts can cause severe injury.

**LOCK OUT POWER** before removing guards or performing maintenance.

1. Complete steps 1 through 3 of “Timing Belt Replacement” section on page 11.
2. Remove taper-lock screws (Figure 18, item 1). Insert one of taper lock screws in remaining hole (Figure 18, item 2). Tighten screw until pulley is loose. Remove pulley and taper hub assembly.

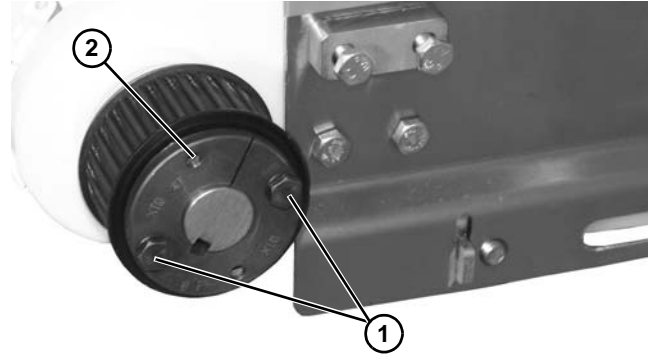

Figure 18

3. To reassemble see steps 5 through 10 of “Installation” section beginning on page 8.

## Motor Replacement

### ⚠ WARNING



#### SEVERE HAZARD!

**LOCK OUT POWER** before removing guards or performing maintenance. Exposed moving parts can cause serious injury.

### ⚠ WARNING



#### BURN HAZARD!

**DO NOT TOUCH** the motor while operating, or shortly after being turned off. Motors may be **HOT** and can cause serious burn injuries.

### ⚠ DANGER



#### ELECTRICAL HAZARD!

**LOCK OUT POWER BEFORE WIRING.** Exposure to high voltage current can cause death or serious injury.

# Preventive Maintenance and Adjustment

1. Loosen terminal box screws (**Figure 19, item 1**) and remove cover (**Figure 19, item 2**).

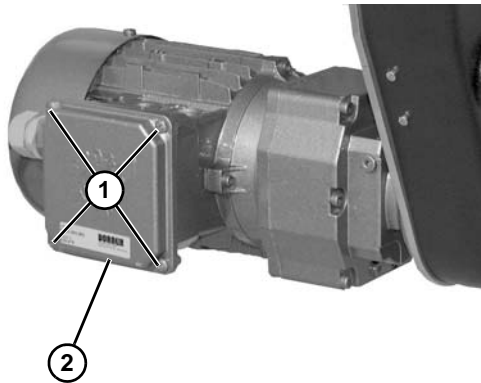
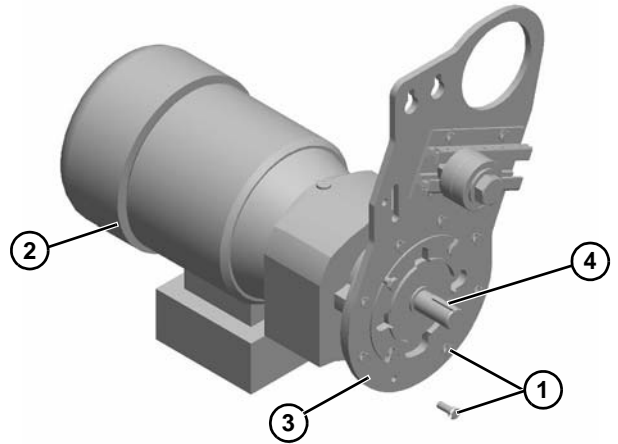

**Figure 19**

2. Refer to the wiring diagram on the inside of the junction box cover.
3. Loosen the wire nuts and disconnect the wires.
4. Loosen the cord grip and remove the cord.

<b>⚠ WARNING</b>
<p style="text-align: center;"><b>CRUSH HAZARD!</b></p> <ul style="list-style-type: none"> <li>• <b>SUPPORT MOTOR PRIOR TO LOOSENING THE BOLTS</b></li> <li>• <b>Loosening motor bolts may cause it to drop down, causing serious injury.</b></li> </ul>

5. Remove the drive pulley. See steps 1 and 2 of “Drive or Driven Pulley Replacement” section on page 12.
6. Remove eight (8) bolts (**Figure 20, item 1**). Detach motor (**Figure 20, item 2**) from the mounting plate (**Figure 20, item 3**). Retain motor output shaft key (**Figure 20, item 4**).



**Figure 20**

7. Remove four (4) bolts (**Figure 21, item 1**). Detach mounting plates (**Figure 21, item 2**) from motor. Install new motor.

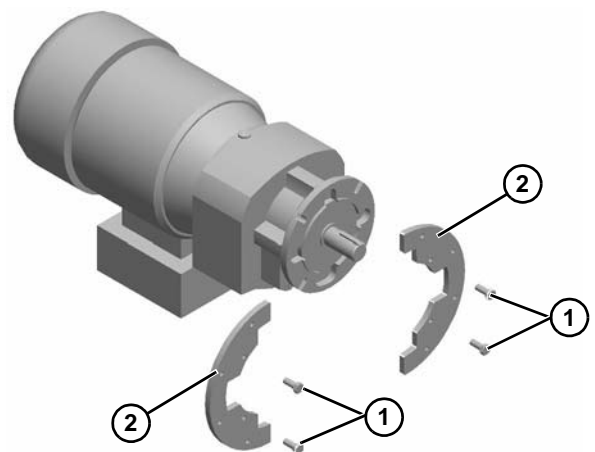

**Figure 21**

8. Re-install the drive pulley, reverse step 2 of “Drive or Driven Pulley Replacement” section on page 12.
9. Complete steps 6 through 10 of “Installation” section beginning on page 8.
10. Rewire the motor and attach the box cover.

# Service Parts

## NOTE

For replacement parts other than those shown in this section, contact an authorized *Dorner Service Center* or the factory. Key Service Parts and Kits are identified by the Performance Parts Kits logo . Dorner recommends keeping these parts on hand.

## Bottom Mount Parallel Drive Package

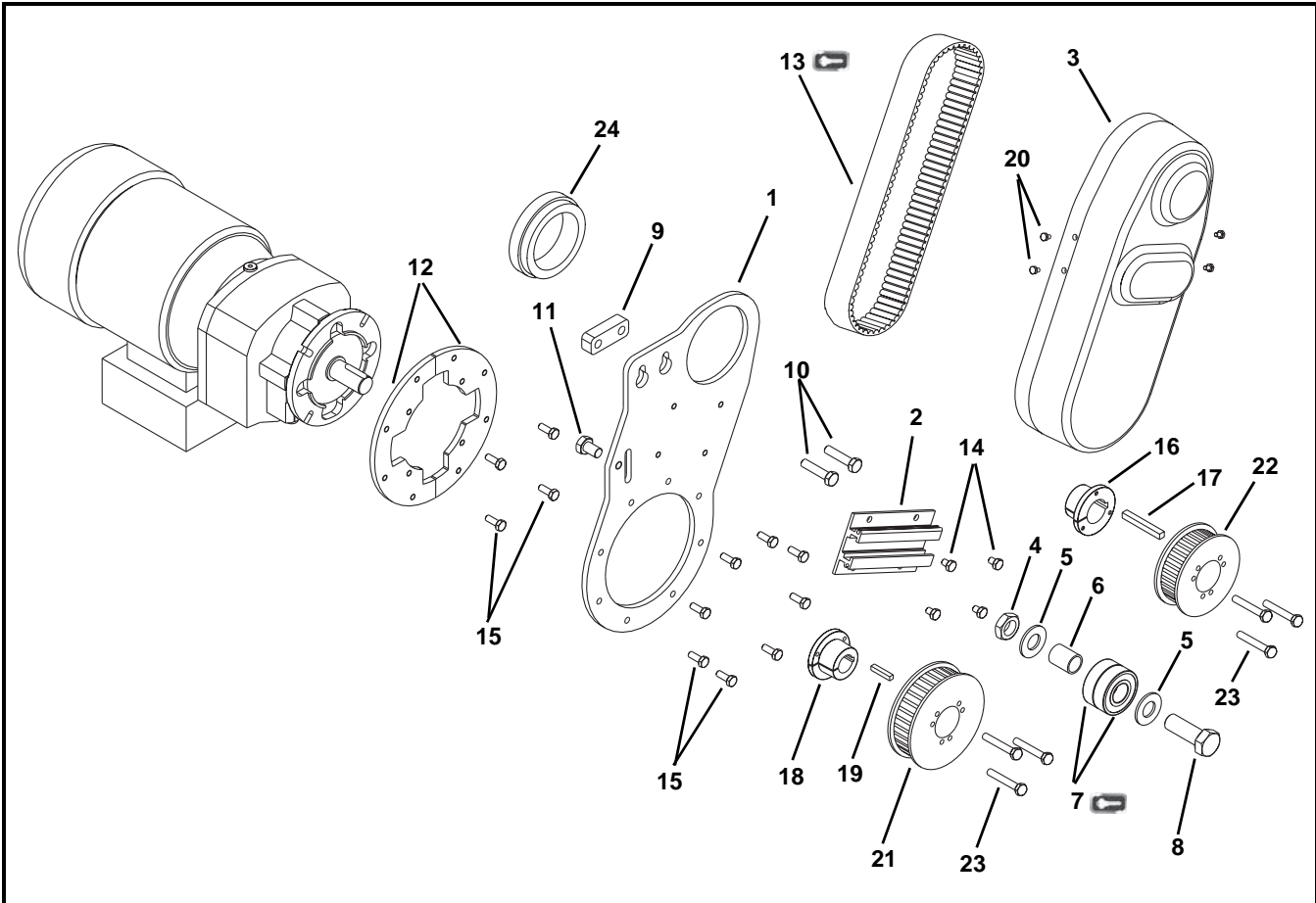

Item	Part Number	Description
1	532229	Mounting Plate
2	301076	Slide Tensioner
3	532227	Drive Cover
4	991610M	Hex Nut
5	911-013	Washer
6	801-124	Bearing
7	802-126	Ball Bearing (Qty: 2)
8	961645M	Hex Head Cap Screw M16-2.00 x 45 mm
9	532231	Spacer
10	960845MSS	Hex Head Cap Screw M8-1.25 x 45 mm
11	961016MSS	Hex Head Cap Screw M10-1.50 x 16 mm
12	532247	Mount Plate
13	814-144	Timing Belt for 30:30 Pulley Ratio
	814-143	Timing Belt for 36:30 Pulley Ratio

Item	Part Number	Description
14	960608MSS	Hex Head Cap Screw M6-1.00 x 8 mm
15	960616MSS	Hex Head Cap Screw M6-1.00 x 16mm
16	532235	Bushing
17	912-110SS	Square Key
18	532236	Bushing
19	912-080SS	Square Key
20	960406MSS	Hex Head Cap Screw M4-0.70 x 6mm
21	532234-30	Drive Pulley 30T
	532234-36	Drive Pulley 36T
22	532234-30	Driven Pulley 30T
23	960645MSS	Hex Head Cap Screw, M6-1.00 x 45 mm
24	514317	Guard

7350 and 7360 Series Bottom Mount Parallel Shaft Drive Package

## Parallel Shaft Gearmotors

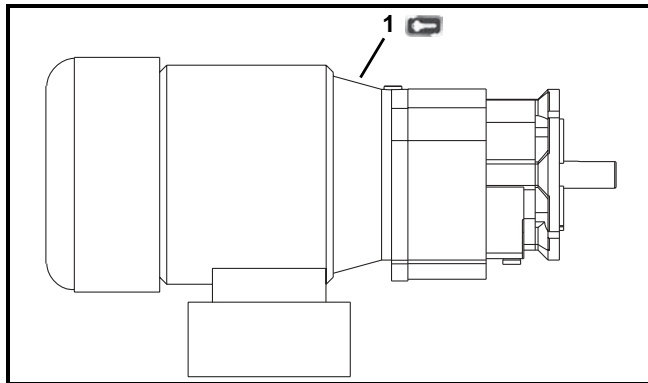

### US Version

Item	Part Number	Description
1 	74M081PS423FN	Motor, 0.16 hp (0.12Kw), 81:1, 230-460 Volts, 60 Hz, 3 Phase
	74M054PS423FN	Motor, 0.25 hp (0.19Kw), 54:1, 230-460 Volts, 60 Hz, 3 Phase
	74M034PS423FN	Motor, 0.50 hp (0.37Kw), 34:1, 230-460 Volts, 60 Hz, 3 Phase
	74M020PS423FN	Motor, 0.75 hp (0.56Kw), 20:1, 230-460 Volts, 60 Hz, 3 Phase
	74M013PS423FN	Motor, 1.00 hp (0.75Kw), 13:1, 230-460 Volts, 60 Hz, 3 Phase
	74M010PS423FN	Motor, 1.00 hp (0.75Kw), 10:1, 230-460 Volts, 60 Hz, 3 Phase
	74M008PS423FN	Motor, 1.00 hp (0.75Kw), 8:1, 230-460 Volts, 60 Hz, 3 Phase
	74M006PS423FN	Motor, 1.00 hp (0.75Kw), 6:1, 230-460 Volts, 60 Hz, 3 Phase
	74M081PS423EN	Motor, 0.16 hp (0.12Kw), 81:1, 230 Volts, 60 Hz
	74M054PS423EN	Motor, 0.25 hp (0.19Kw), 54:1, 230 Volts, 60 Hz
	74M034PS423EN	Motor, 0.50 hp (0.37Kw), 34:1, 230 Volts, 60 Hz
	74M020PS423EN	Motor, 0.75 hp (0.56Kw), 20:1, 230 Volts, 60 Hz
	74M013PS423EN	Motor, 1.00 hp (0.75Kw), 13:1, 230 Volts, 60 Hz
	74M010PS423EN	Motor, 1.00 hp (0.75Kw), 10:1, 230 Volts, 60 Hz
	74M008PS423EN	Motor, 1.00 hp (0.75Kw), 8:1, 230 Volts, 60 Hz
	74M006PS423EN	Motor, 1.00 hp (0.75Kw), 6:1, 230 Volts, 60 Hz

### CE Version

Item	Part Number	Description
1 	73U081PS423FN	Gearmotor, Fixed Speed, 0.12 Kw, 230/400 Volts, 3 Phase, 50 Hz, 17 RPM
	73U039PS423FN	Gearmotor, Fixed Speed, 0.37 Kw, 230/400 Volts, 3 Phase, 50 Hz, 36 RPM
	73U029PS423FN	Gearmotor, Fixed Speed, 0.56 Kw, 230/400 Volts, 3 Phase, 50 Hz, 48 RPM
	73U019PS423FN	Gearmotor, Fixed Speed, 0.75 Kw, 230/400 Volts, 3 Phase, 50 Hz, 74 RPM
	73U016PS423FN	Gearmotor, Fixed Speed, 0.75 Kw, 230/400 Volts, 3 Phase, 50 Hz, 88 RPM
	73U011PS423FN	Gearmotor, Fixed Speed, 1.12 Kw, 230/400 Volts, 3 Phase, 50 Hz, 127 RPM
	73U009PS423FN	Gearmotor, Fixed Speed, 1.12 Kw, 230/400 Volts, 3 Phase, 50 Hz, 158 RPM
	73U007PS423FN	Gearmotor, Fixed Speed, 0.75 Kw, 230/400 Volts, 3 Phase, 50 Hz, 194 RPM
	73U081PS423EN	Gearmotor, Variable Speed, 0.12 Kw, 230/400 Volts, 3 Phase, 12-80 Hz, 27 RPM
	73U039PS423EN	Gearmotor, Variable Speed, 0.37 Kw, 230/400 Volts, 3 Phase, 12-80 Hz, 58 RPM
	73U029PS423EN	Gearmotor, Variable Speed, 0.56 Kw, 230/400 Volts, 3 Phase, 12-80 Hz, 77 RPM
	73U019PS423EN	Gearmotor, Variable Speed, 0.75 Kw, 230/400 Volts, 3 Phase, 12-80 Hz, 118 RPM
	73U016PS423EN	Gearmotor, Variable Speed, 0.75 Kw, 230/400 Volts, 3 Phase, 12-80 Hz, 141 RPM
	73U011PS423EN	Gearmotor, Variable Speed, 1.12 Kw, 230/400 Volts, 3 Phase, 12-80 Hz, 203 RPM
	73U009PS423EN	Gearmotor, Variable Speed, 1.12 Kw, 230/400 Volts, 3 Phase, 12-80 Hz, 253 RPM

# Return Policy

Returns must have prior written factory authorization or they will not be accepted. Items that are returned to Dorner without authorization will not be credited nor returned to the original sender. When calling for authorization, please have the following information ready for the Dorner factory representative or your local distributor:

1. Name and address of customer.
2. Dorner part number(s) of item(s) being returned.
3. Reason for return.
4. Customer's original order number used when ordering the item(s).
5. Dorner or distributor invoice number (if available, part serial number).

A representative will discuss action to be taken on the returned items and provide a Returned Goods Authorization (RMA) number for reference. RMA will automatically close 30 days after being issued. To get credit, items must be new and undamaged. There will be a return charge on all items returned for credit, where Dorner was not at fault. It is the customer's responsibility to prevent damage during return shipping. Damaged or modified items will not be accepted. The customer is responsible for return freight.

Product Type									
Standard Products									Engineered to order parts
Product Line	Conveyors	Gearmotors & Mounting Packages	Support Stands	Accessories	Spare Parts (non-belt)	Spare Belts - Standard Flat Fabric	Spare Belts - Cleated & Specialty Fabric	Spare Belts - Plastic Chain	All equipment and parts
1100	30% return fee for all products except: 50% return fee for conveyors with modular belt, cleated belt or specialty belts						non-returnable		case-by-case
2200									
2200 Modular Belt									
2200 Precision Move									
2300									
2300 Modular Belt									
3200									
3200 LPZ									
3200 Precision Move									
4100									
5200									
5300									
6200									
Controls									
7200 / 7300	50% return fee for all products								
7350	non-returnable								
7360									
7400									
7600									

Returns will not be accepted after 60 days from original invoice date. The return charge covers inspection, cleaning, disassembly, disposal and reissuing of components to inventory. If a replacement is needed prior to evaluation of returned item, a purchase order must be issued. Credit (if any) is issued only after return and evaluation is complete.

Dorner has representatives throughout the world. Contact Dorner for the name of your local representative. Our Customer Service Team will gladly help with your questions on Dorner products.

For a copy of Dorner's Warranty, contact factory, distributor, service center or visit our website at [www.dorner.com](http://www.dorner.com).

For replacement parts, contact an authorized Dorner Service Center or the factory.

 <p>Dorner Mfg. Corp. reserves the right to change or discontinue products without notice. All products and services are covered in accordance with our standard warranty. All rights reserved. © Dorner Mfg. Corp. 2015</p>	<p><b>DORNER MFG. CORP.</b>            975 Cottonwood Ave., PO Box 20            Hartland, WI 53029-0020 USA            TEL 1-800-397-8664 (USA)            FAX 1-800-369-2440 (USA)            Internet: <a href="http://www.dorner.com">www.dorner.com</a></p>	<p>Outside the USA:            TEL 1-262-367-7600            FAX 1-262-367-5827</p>
---	--	---