



2200 and 2300 Series iDrive Conveyors

Installation, Maintenance & Parts Manual



2200 Series Conveyor



2300 Series Conveyor

DORNER MFG. CORP.
P.O. Box 20 • 975 Cottonwood Ave.
Hartland, WI 53029-0020 USA

INSIDE THE USA
TEL: 1-800-397-8664
FAX: 1-800-369-2440

OUTSIDE THE USA
TEL: 262-367-7600
FAX: 262-367-5827

For other service manuals visit our website at:
www.dorner.com/service_manuals.asp

Table of Contents

Introduction	2	Cleaning	21
Warnings – General Safety	3	Conveyor Belt Replacement	21
Product Description	4	Conveyor Belt Replacement Sequence	21
Specifications	4	Belt Removal	21
Models	4	Belt Installation	22
Flat Belt 2200 Series Conveyor	4	Conveyor Belt Tensioning	22
Cleated Belt 2200 Series Conveyor	4	Conveyors with 1.25" (32 mm) Diameter Pulleys	23
2300 Series DustPruf Flat Belt Conveyor	5	Conveyors with Nose Bar Idlers	23
2300 Series DustPruf Cleated Belt Conveyor	5	Conveyor Belt Tracking	24
CE Specifications	5	V-Guided Belts	24
Conveyor Supports	5	Non V-Guided Belts	24
Maximum Distances	5	Spindle Removal	25
Specifications	6	A – Idler Spindle Removal	25
Motor Specifications	6	B – Drive Spindle Removal	25
iDrive Load Capacity (lbs)	7	Bearing Removal & Replacement	27
Installation	12	Spindle Installation	28
Required Tools	12	Idler Spindle Installation	28
Recommended Installation Sequence	12	Drive Spindle Installation	28
2200 Series Mounting Brackets	12	Nose Bar Roller Replacement	30
2300 Series Mounting Brackets	13	Motor Removal and Replacement	30
Return Rollers	14	Service Parts	32
Cleated Belt and 2 - 6" (51 - 152 mm) Wide		Drive End	32
Flat Belt Conveyors	14	Idler End	34
8 - 18" (203 - 457 mm) Wide Flat Belt Conveyors	15	Nose Bar Idler End	35
Proper Methods of Attachment to Side Rails		-04 3" (76 mm) Aluminum Side	36
(2300 Series Only)	15	-05 1.5" (38 mm) Aluminum Side	37
Self-Drilling Screws	15	-07 Low to Side Wiper	38
Pre-Drill for Standard Screws	16	-09 Low to High Side	39
Guiding (2300 Series Only)	17	-10.5" (13 mm) Extruded Plastic	40
Wiring	17	-13 Adjustable Guiding	41
Cover Mounted Controls		-14 Tool-Less Adjustable Guiding	42
with 115 volt Power Supply	17	0.5" (13 mm) Cleated Belt Guiding	43
Cover Mounted Controls		1" (25 mm) Cleated Belt Guiding	44
with Customer Provided Power Supply	18	2" (51 mm) Cleated Belt Guiding	45
Cover Mounted Controls	18	Flared Side Guiding	46
Cover Mounted Controls		Flat Belt Stand Mount Assembly	47
with Remote Start/Stop Cable	18	Cleated Belt Stand Mount Assembly	48
Cover Mounted Controls with Photo Eye Option	19	Flat Belt Stand Mount Assembly	
Customer Wired Controls with Flying Leads	20	for 2" (610 mm) Conveyors	49
Preventive Maintenance and Adjustment	21	Cleated Belt Stand Mount Assembly	
Required Tools	21	for 2" (610 mm) Conveyors	50
Standard Tools	21	3" (70 mm) to 6" (152 mm) Flat Belt Return Roller	51
Special Tools	21	8" (203 mm) to 18" (457 mm) Flat Belt Return Roller	51
Checklist	21	Cleated Belt Return Roller	52
Lubrication	21	Photo Eye	52
Maintaining Conveyor Belt	21	Conveyor Belt Part Number Configuration	53
Troubleshooting	21	Return Policy	54

Introduction

IMPORTANT

Some illustrations may show guards removed. DO NOT operate equipment without guards.

Upon receipt of shipment:

- Compare shipment with packing slip. Contact factory regarding discrepancies.
- Inspect packages for shipping damage. Contact carrier regarding damage.
- Accessories may be shipped loose. See accessory instructions for installation.

Dorner's Limited Warranty applies.

Dorner has convenient, pre-configured kits of Key Service Parts for all conveyor products. These time saving kits are easy to order, designed for fast installation, and guarantee you will have what you need when you need it. Key Parts and Kits are marked in the Service Parts section of this manual with the Performance Parts Kits logo .

Dorner 2200 and 2300 series conveyors are covered by Patent Numbers 5,174,435, 6,298,981, 6,422,382 and corresponding patents and patent applications in other countries.

Dorner reserves the right to make changes at any time without notice or obligation.

Warnings – General Safety

⚠ DANGER



SEVERE HAZARD!
KEEP OFF CONVEYORS. Climbing, sitting, walking or riding on conveyor will result in death or serious injury.

⚠ DANGER



EXPLOSION HAZARD!

- DO NOT OPERATE CONVEYORS IN AN EXPLOSIVE ENVIRONMENT. The electric gearmotor generates heat and could ignite combustible vapors.
- Failure to comply will result in death or serious injury.

⚠ WARNING



CRUSH HAZARD!

- DO NOT place hands or fingers inside the conveyor while it is running.
- DO NOT wear loose garments while operating the conveyor. Loose garments can become caught up in the conveyor.
- Failure to comply could result in serious injury.

⚠ WARNING



CRUSH HAZARD!

- SUPPORT CONVEYOR SECTIONS PRIOR TO LOOSENING STAND HEIGHT OR ANGLE ADJUSTMENT SCREWS.
- Loosening stand height or angle adjustment screws may cause conveyor sections to drop down, causing serious injury.

⚠ WARNING



SEVERE HAZARD!
LOCK OUT POWER before removing guards or performing maintenance. Exposed moving parts can cause serious injury.

⚠ WARNING



BURN HAZARD!
DO NOT TOUCH the motor while operating, or shortly after being turned off. Motors may be HOT and can cause serious burn injuries.

⚠ WARNING



PUNCTURE HAZARD!
Handle drive shaft keyway with care. It may be sharp and could puncture the skin, causing serious injury.

⚠ WARNING



SEVERE HAZARD!

- Dorner cannot control the physical installation and application of conveyors. Taking protective measures is the responsibility of the user.
- When conveyors are used in conjunction with other equipment or as part of a multiple conveyor system, CHECK FOR POTENTIAL PINCH POINTS and other mechanical hazards before system start-up.
- Failure to comply could result in serious injury.

Product Description

Typical Conveyor Components Figure 1:

- | | |
|---|-------------------|
| 1 | Conveyor |
| 2 | Support Stand |
| 3 | Drive End |
| 4 | Idler/Tension End |

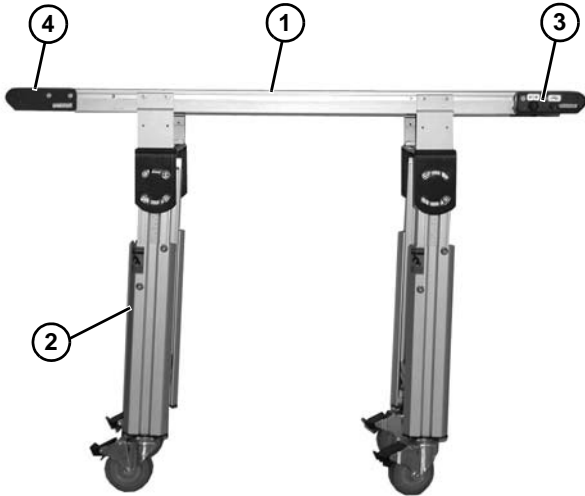

Figure 1

Typical Controller Components Figure 2:

- | | |
|---|---------------------------|
| 1 | Speed Control |
| 2 | Directional On/Off Switch |

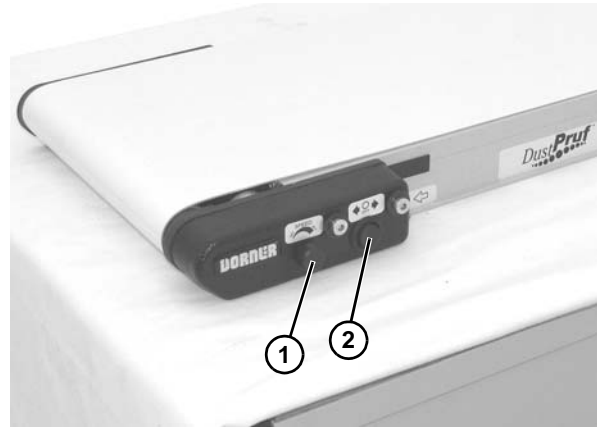

Figure 2

Specifications

Models

Flat Belt 2200 Series Conveyor

Flat Belt 2200 Series Conveyor

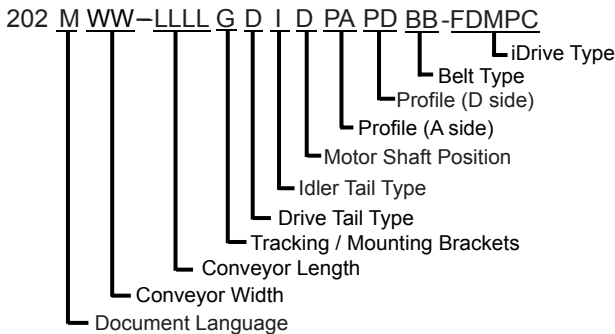

Cleated Belt 2200 Series Conveyor

Cleated Belt 2200 Series Conveyor

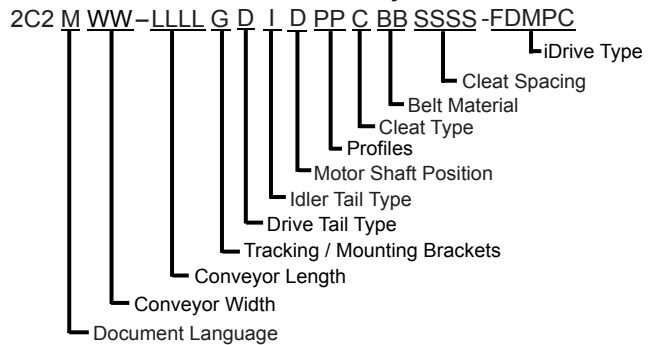

2300 Series DustPruf Flat Belt Conveyor

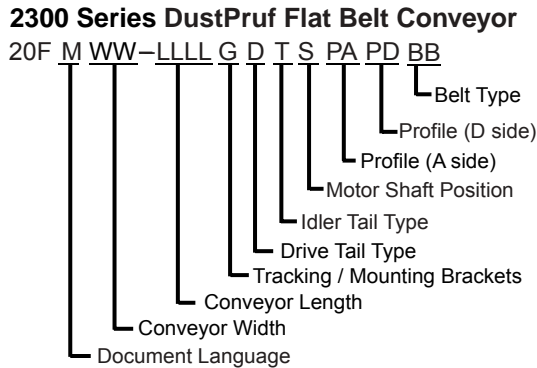

Conveyor Supports:

Maximum Distances

- 1 = 18" (457 mm)
- 2 = 18" (457 mm)
- 3 = 72" (1828 mm)

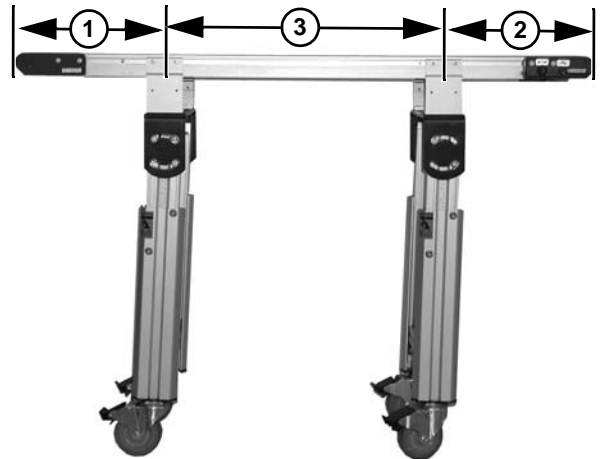
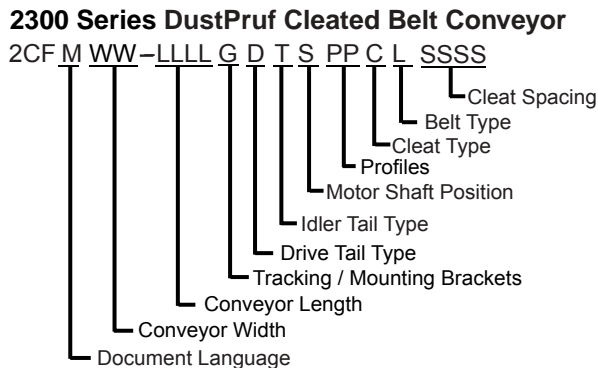

Figure 3

2300 Series DustPruf Cleated Belt Conveyor



CE Specifications

1. CE Marked Models are "U" Document Language code only.
2. CE Marked Models are not equipped with high voltage power supply. Conveyor operates on 24VDC. Selection and final installation of CE rated power supply are the responsibility of the end user.
3. CE Marked Models operate on 24VDC. Emergency stops, wiring, and control circuits are not provided. Selection and final installation of CE rated emergency stops and control circuits are the responsibility of the end user.
4. CE Marked Models contain no application control circuits. If power is disconnected and reconnected this machine will restart automatically. Selection and final installation of CE rated control circuits are the responsibility of the end user.

Specifications

Specifications

Conveyor Width Reference (WW)	02	03	04	05	06	08	10	12	18
Conveyor Belt Width	1.75" (44mm)	2.75" (70mm)	3.75" (95mm)	5" (127mm)	6" (152mm)	8" (203mm)	10" (254mm)	12" (305mm)	18" (457mm)
Maximum Conveyor Load	See Load Capacity Chart								
Belt Travel	4.0" (88 mm) per revolution of spindle								
Maximum Belt Speed*	70 ft/minute (21 m/minute)								
Belt Takeup	0.38" (10 mm) of stroke = 0.75" (19 mm) of belt take-up								

Conveyor Length Reference (LLLL)	0200 - 0800 in 0001 increments
Conveyor Length	2 ft (610 mm) to 8 ft (2438 mm) in 0.12" (3 mm) increments

* See Ordering and Specifications Catalog for details.

NOTE

Maximum conveyor loads based on:

- *Non-accumulating product*
- *Product moving towards gearmotor*
- *Conveyor being mounted horizontal*

Motor Specifications

Output Power	25 watt	25 watt
Motor Voltage	24 volt DC, 0.8 amp	24 volt DC, 0.8 amp
Transformer Voltage	100-240 VAC, 50/60 Hz	100-240 VAC, 50/60 Hz
Gearmotor Ratio	23:1	66:1
Motor Type	Brushless DC	Brushless DC
Belt Speeds	7-70 Ft./Min., 5-50 Ft./Min.	2.4-24 Ft./Min., 1.7-17 Ft./Min.
Duty Cycle	Non-Continuous Duty	Non-Continuous Duty
Index Capability	Up to 30 per Minute	Up to 30 per Minute

Specifications

iDrive Load Capacity (lbs)

		7 - 70 Ft./Min. FOR BELT TYPE 09										
		LENGTH										
		2	3	4	5	6	7	8	9	10	11	12
WIDTH	2	13	13	13	13	12	12	0	0	0	0	0
	3	13	13	13	13	12	12	0	0	0	0	0
	4	11	11	11	11	11	10	0	0	0	0	0
	5	11	11	10	10	10	10	0	0	0	0	0
	6	10	10	10	10	9	9	0	0	0	0	0
	8	9	9	9	8	8	8	0	0	0	0	0
	10	0	0	0	0	0	0	0	0	0	0	0
	12	0	0	0	0	0	0	0	0	0	0	0
	18	0	0	0	0	0	0	0	0	0	0	0
24	0	0	0	0	0	0	0	0	0	0	0	

		5 - 50 Ft./Min. FOR BELT TYPE 09										
		LENGTH										
		2	3	4	5	6	7	8	9	10	11	12
WIDTH	2	24	24	24	24	24	24	0	0	0	0	0
	3	24	24	24	24	24	24	0	0	0	0	0
	4	22	22	22	22	22	22	0	0	0	0	0
	5	22	22	22	21	21	21	0	0	0	0	0
	6	21	21	21	21	21	20	0	0	0	0	0
	8	20	20	20	20	19	19	0	0	0	0	0
	10	17	17	17	16	16	0	0	0	0	0	0
	12	15	15	14	0	0	0	0	0	0	0	0
	18	0	0	0	0	0	0	0	0	0	0	0
24	0	0	0	0	0	0	0	0	0	0	0	

		2.4 - 24 Ft./Min. FOR BELT TYPE 09										
		LENGTH										
		2	3	4	5	6	7	8	9	10	11	12
WIDTH	2	25	25	25	25	25	25	0	0	0	0	0
	3	25	25	25	25	25	25	0	0	0	0	0
	4	25	25	25	25	25	25	0	0	0	0	0
	5	25	25	25	25	25	25	0	0	0	0	0
	6	25	25	25	25	25	25	0	0	0	0	0
	8	25	25	25	25	25	25	0	0	0	0	0
	10	25	25	25	25	25	0	0	0	0	0	0
	12	25	25	25	0	0	0	0	0	0	0	0
	18	25	25	0	0	0	0	0	0	0	0	0
24	25	25	0	0	0	0	0	0	0	0	0	

		1.7 - 17 Ft./Min. FOR BELT TYPE 09										
		LENGTH										
		2	3	4	5	6	7	8	9	10	11	12
WIDTH	2	25	25	25	25	25	25	0	0	0	0	0
	3	25	25	25	25	25	25	0	0	0	0	0
	4	25	25	25	25	25	25	0	0	0	0	0
	5	25	25	25	25	25	25	0	0	0	0	0
	6	25	25	25	25	25	25	0	0	0	0	0
	8	25	25	25	25	25	25	0	0	0	0	0
	10	25	25	25	25	25	0	0	0	0	0	0
	12	25	25	25	0	0	0	0	0	0	0	0
	18	25	25	0	0	0	0	0	0	0	0	0
24	25	25	0	0	0	0	0	0	0	0	0	

Specifications

iDrive Load Capacity (lbs) (continued)

		7 - 70 Ft./Min. FOR DOUBLE CARCASS BELT TYPE 05										
		LENGTH										
		2	3	4	5	6	7	8	9	10	11	12
WIDTH	2	9	9	8	8	8	8	0	0	0	0	0
	3	9	9	5	8	8	8	0	0	0	0	0
	4	7	7	7	7	6	6	0	0	0	0	0
	5	6	6	6	6	6	6	0	0	0	0	0
	6	6	6	6	6	5	5	0	0	0	0	0
	8	0	0	0	0	0	0	0	0	0	0	0
	10	0	0	0	0	0	0	0	0	0	0	0
	12	0	0	0	0	0	0	0	0	0	0	0
	18	0	0	0	0	0	0	0	0	0	0	0
24	0	0	0	0	0	0	0	0	0	0	0	

		5 - 50 Ft./Min. FOR DOUBLE CARCASS BELT TYPE 05										
		LENGTH										
		2	3	4	5	6	7	8	9	10	11	12
WIDTH	2	20	20	20	20	20	20	0	0	0	0	0
	3	20	20	20	20	20	20	0	0	0	0	0
	4	18	18	18	18	18	18	0	0	0	0	0
	5	18	18	18	17	17	17	0	0	0	0	0
	6	17	17	17	17	17	17	0	0	0	0	0
	8	16	16	16	16	15	15	0	0	0	0	0
	10	13	13	13	12	12	0	0	0	0	0	0
	12	11	11	10	0	0	0	0	0	0	0	0
	18	0	0	0	0	0	0	0	0	0	0	0
24	0	0	0	0	0	0	0	0	0	0	0	

		2.4 - 24 Ft./Min. FOR DOUBLE CARCASS BELT TYPE 05										
		LENGTH										
		2	3	4	5	6	7	8	9	10	11	12
WIDTH	2	25	25	25	25	25	25	0	0	0	0	0
	3	25	25	25	25	25	25	0	0	0	0	0
	4	25	25	25	25	25	25	0	0	0	0	0
	5	25	25	25	25	25	25	0	0	0	0	0
	6	25	25	25	25	25	25	0	0	0	0	0
	8	25	25	25	25	25	25	0	0	0	0	0
	10	25	25	25	25	25	0	0	0	0	0	0
	12	25	25	25	0	0	0	0	0	0	0	0
	18	25	25	0	0	0	0	0	0	0	0	0
24	25	24	0	0	0	0	0	0	0	0	0	

		1.7 - 17 Ft./Min. FOR DOUBLE CARCASS BELT TYPE 05										
		LENGTH										
		2	3	4	5	6	7	8	9	10	11	12
WIDTH	2	25	25	25	25	25	25	0	0	0	0	0
	3	25	25	25	25	25	25	0	0	0	0	0
	4	25	25	25	25	25	25	0	0	0	0	0
	5	25	25	25	25	25	25	0	0	0	0	0
	6	25	25	25	25	25	25	0	0	0	0	0
	8	25	25	25	25	25	25	0	0	0	0	0
	10	25	25	25	25	25	0	0	0	0	0	0
	12	25	25	25	0	0	0	0	0	0	0	0
	18	25	25	0	0	0	0	0	0	0	0	0
24	25	25	0	0	0	0	0	0	0	0	0	

2200 and 2300 Series iDrive Conveyors

iDrive Load Capacity (lbs) (continued)

		7 - 70 Ft./Min. FOR SINGLE PLY BELT TYPES 19 AND 53										
		LENGTH										
		2	3	4	5	6	7	8	9	10	11	12
WIDTH	2	19	19	19	19	19	19	0	0	0	0	0
	3	19	19	19	19	19	19	0	0	0	0	0
	4	17	17	17	17	17	17	0	0	0	0	0
	5	17	17	17	17	17	16	0	0	0	0	0
	6	16	16	16	16	16	16	0	0	0	0	0
	8	15	15	15	15	15	15	0	0	0	0	0
	10	12	12	12	12	12	0	0	0	0	0	0
	12	10	10	10	0	0	0	0	0	0	0	0
	18	0	0	0	0	0	0	0	0	0	0	0
24	0	0	0	0	0	0	0	0	0	0	0	

		5 - 50 Ft./Min. FOR SINGLE PLY BELT TYPES 19 AND 53										
		LENGTH										
		2	3	4	5	6	7	8	9	10	11	12
WIDTH	2	25	25	25	25	25	25	0	0	0	0	0
	3	25	25	25	25	25	25	0	0	0	0	0
	4	25	25	25	25	25	25	0	0	0	0	0
	5	25	25	25	25	25	25	0	0	0	0	0
	6	25	25	25	25	25	25	0	0	0	0	0
	8	25	25	25	25	25	25	0	0	0	0	0
	10	23	23	23	23	23	0	0	0	0	0	0
	12	21	21	21	0	0	0	0	0	0	0	0
	18	16	16	0	0	0	0	0	0	0	0	0
24	10	10	0	0	0	0	0	0	0	0	0	

		2.4 - 24 Ft./Min. FOR SINGLE PLY BELT TYPES 19 AND 53										
		LENGTH										
		2	3	4	5	6	7	8	9	10	11	12
WIDTH	2	25	25	25	25	25	25	0	0	0	0	0
	3	25	25	25	25	25	25	0	0	0	0	0
	4	25	25	25	25	25	25	0	0	0	0	0
	5	25	25	25	25	25	25	0	0	0	0	0
	6	25	25	25	25	25	25	0	0	0	0	0
	8	25	25	25	25	25	25	0	0	0	0	0
	10	25	25	25	25	25	0	0	0	0	0	0
	12	25	25	25	0	0	0	0	0	0	0	0
	18	25	25	0	0	0	0	0	0	0	0	0
24	25	25	0	0	0	0	0	0	0	0	0	

		1.7 - 17 Ft./Min. FOR SINGLE PLY BELT TYPES 19 AND 53										
		LENGTH										
		2	3	4	5	6	7	8	9	10	11	12
WIDTH	2	25	25	25	25	25	25	0	0	0	0	0
	3	25	25	25	25	25	25	0	0	0	0	0
	4	25	25	25	25	25	25	0	0	0	0	0
	5	25	25	25	25	25	25	0	0	0	0	0
	6	25	25	25	25	25	25	0	0	0	0	0
	8	25	25	25	25	25	25	0	0	0	0	0
	10	25	25	25	25	25	0	0	0	0	0	0
	12	25	25	25	0	0	0	0	0	0	0	0
	18	25	25	0	0	0	0	0	0	0	0	0
24	25	25	0	0	0	0	0	0	0	0	0	

Specifications

iDrive Load Capacity (lbs) (continued)

		7 - 70 Ft./Min. FOR ALL OTHER BELT TYPES										
		LENGTH										
		2	3	4	5	6	7	8	9	10	11	12
WIDTH	2	6	5	5	5	5	5	0	0	0	0	0
	3	6	5	5	5	5	5	0	0	0	0	0
	4	0	0	0	0	0	0	0	0	0	0	0
	5	0	0	0	0	0	0	0	0	0	0	0
	6	0	0	0	0	0	0	0	0	0	0	0
	8	0	0	0	0	0	0	0	0	0	0	0
	10	0	0	0	0	0	0	0	0	0	0	0
	12	0	0	0	0	0	0	0	0	0	0	0
	18	0	0	0	0	0	0	0	0	0	0	0
24	0	0	0	0	0	0	0	0	0	0	0	

		5 - 50 Ft./Min. FOR ALL OTHER BELT TYPES										
		LENGTH										
		2	3	4	5	6	7	8	9	10	11	12
WIDTH	2	17	17	17	17	16	16	0	0	0	0	0
	3	17	17	17	17	16	16	0	0	0	0	0
	4	15	15	15	15	15	14	0	0	0	0	0
	5	15	15	14	14	14	14	0	0	0	0	0
	6	14	14	14	14	13	13	0	0	0	0	0
	8	13	13	13	12	12	12	0	0	0	0	0
	10	10	10	9	9	9	0	0	0	0	0	0
	12	0	0	0	0	0	0	0	0	0	0	0
	18	0	0	0	0	0	0	0	0	0	0	0
24	0	0	0	0	0	0	0	0	0	0	0	

		2.4 - 24 Ft./Min. FOR ALL OTHER BELT TYPES										
		LENGTH										
		2	3	4	5	6	7	8	9	10	11	12
WIDTH	2	25	25	25	25	25	25	0	0	0	0	0
	3	25	25	25	25	25	25	0	0	0	0	0
	4	25	25	25	25	25	25	0	0	0	0	0
	5	25	25	25	25	25	25	0	0	0	0	0
	6	25	25	25	25	25	25	0	0	0	0	0
	8	25	25	25	25	25	25	0	0	0	0	0
	10	25	25	25	25	25	0	0	0	0	0	0
	12	25	25	25	0	0	0	0	0	0	0	0
	18	25	25	0	0	0	0	0	0	0	0	0
24	22	21	0	0	0	0	0	0	0	0	0	

		1.7 - 17 Ft./Min. FOR ALL OTHER BELT TYPES										
		LENGTH										
		2	3	4	5	6	7	8	9	10	11	12
WIDTH	2	25	25	25	25	25	25	0	0	0	0	0
	3	25	25	25	25	25	25	0	0	0	0	0
	4	25	25	25	25	25	25	0	0	0	0	0
	5	25	25	25	25	25	25	0	0	0	0	0
	6	25	25	25	25	25	25	0	0	0	0	0
	8	25	25	25	25	25	25	0	0	0	0	0
	10	25	25	25	25	25	0	0	0	0	0	0
	12	25	25	25	0	0	0	0	0	0	0	0
	18	25	25	0	0	0	0	0	0	0	0	0
24	25	25	0	0	0	0	0	0	0	0	0	

2200 and 2300 Series iDrive Conveyors

iDrive Load Capacity (lbs) (continued)

		2.4 - 24 Ft./Min. FOR NOSE BAR BELTS										
		LENGTH										
		2	3	4	5	6	7	8	9	10	11	12
WIDTH	2	20	20	20	20	20	20	0	0	0	0	0
	3	20	20	20	20	20	20	0	0	0	0	0
	4	18	18	18	18	18	18	0	0	0	0	0
	5	18	18	18	18	18	17	0	0	0	0	0
	6	17	17	17	17	17	17	0	0	0	0	0
	8	16	16	16	16	16	15	0	0	0	0	0
	10	13	13	13	12	12	0	0	0	0	0	0
	12	11	11	11	0	0	0	0	0	0	0	0
	18	0	0	0	0	0	0	0	0	0	0	0
24	0	0	0	0	0	0	0	0	0	0	0	

		1.7 - 17 Ft./Min. FOR NOSE BAR BELTS										
		LENGTH										
		2	3	4	5	6	7	8	9	10	11	12
WIDTH	2	25	25	25	25	25	25	0	0	0	0	0
	3	25	25	25	25	25	25	0	0	0	0	0
	4	25	25	25	25	25	25	0	0	0	0	0
	5	25	25	25	25	25	25	0	0	0	0	0
	6	25	25	25	25	25	25	0	0	0	0	0
	8	25	25	25	25	25	25	0	0	0	0	0
	10	25	25	25	25	25	0	0	0	0	0	0
	12	25	25	25	0	0	0	0	0	0	0	0
	18	25	25	0	0	0	0	0	0	0	0	0
24	25	25	0	0	0	0	0	0	0	0	0	

Installation

NOTE

Conveyor **MUST** be mounted straight, flat and level within confines of conveyor. Use a level (**Figure 4, item 1**) for setup.



Figure 4

Installation Component List

Conveyor frame (two sections if longer than 12ft)
Conveyor brackets (4x)
Return rollers (for longer conveyors)

Required Tools

- Hex-key wrenches:
4 mm, 5 mm
- Level
- Torque wrench

Recommended Installation Sequence

- Attach mounting brackets to conveyor
- Attach conveyor to stands
- Install return rollers on conveyor (optional)
- Attach guides/accessories (see page 32 through page 52 of “Service Parts” section for details)
- 2200 Series only: Remove and discard shipping brackets (**Figure 5, item 1**).

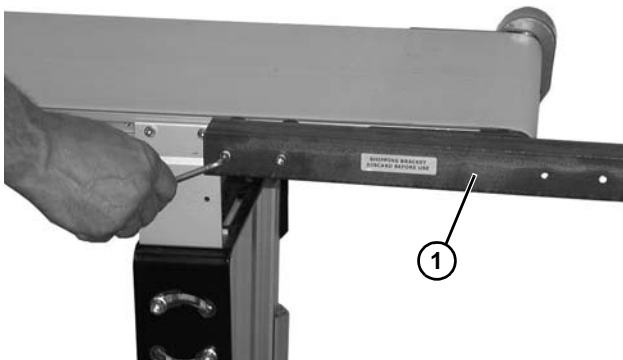

Figure 5

2200 Series Mounting Brackets

1. Locate brackets. Exploded views shown in **Figure 6** and **Figure 7**.

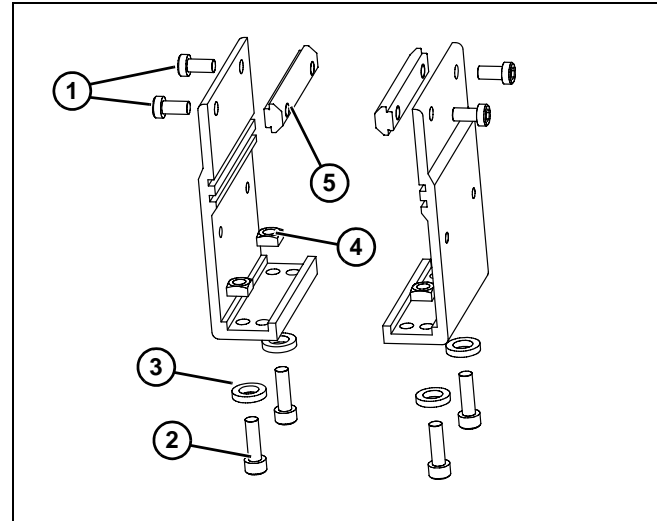

Figure 6

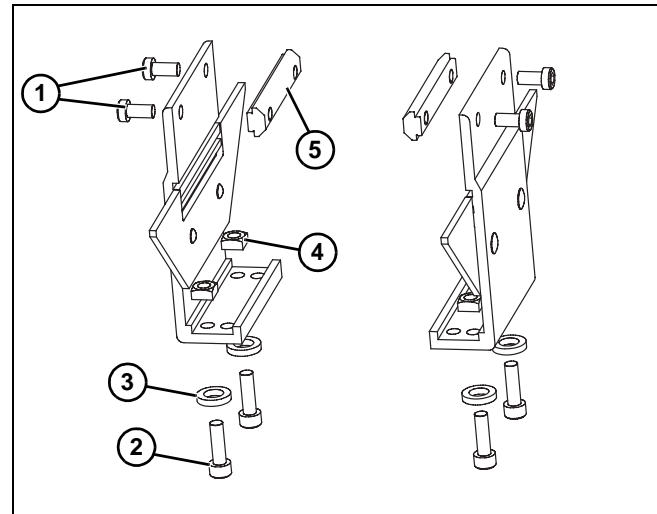

Figure 7

2. Remove screws (**Figure 6, item 1 and 2**) or (**Figure 7, item 1 and 2**), washers (**Figure 6, item 3**) or (**Figure 7, item 3**), nuts (**Figure 6, item 4**) or (**Figure 7, item 4**), and T-bars (**Figure 6, item 5**) or (**Figure 7, item 5**), from brackets.

3. Insert T-bars (Figure 6, item 5) or (Figure 7, item 5) into conveyor side slots (Figure 8, item 1). Fasten brackets (Figure 8, item 2) to conveyor with mounting screws (Figure 8, item 3).

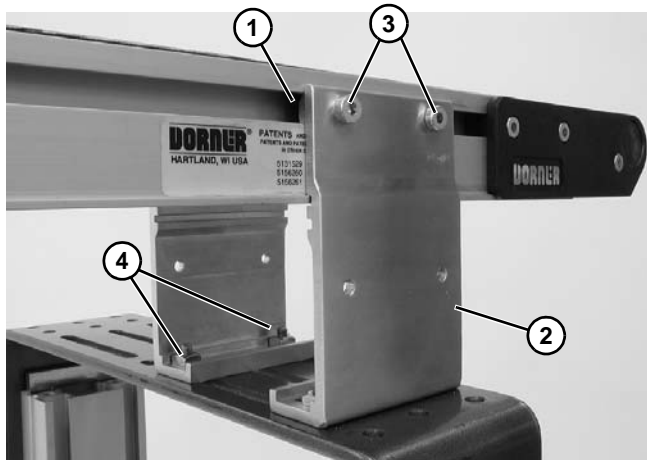

Figure 8

NOTE

Mounting brackets for flat belt conveyors shown.

4. Fasten brackets to support stand with mounting screws, washers, and nuts (Figure 8, item 4).
5. Tighten screws (Figure 8, item 3), and mounting screws on nuts (Figure 8, item 4) to 60 in-lb (7 Nm).

2300 Series Mounting Brackets

1. Locate brackets. Exploded views shown in Figure 9 for flat belt & Figure 10 for a cleated belt.

⚠ WARNING

Installing self-drilling screws into the DustPruf side rail requires substantial force.

Failure to properly support the conveyor while installing self-drilling screws may cause the operator or conveyor to slip, causing severe injury.

SUPPORT CONVEYOR FRAMES WHILE INSTALLING SELF-DRILLING SCREWS.

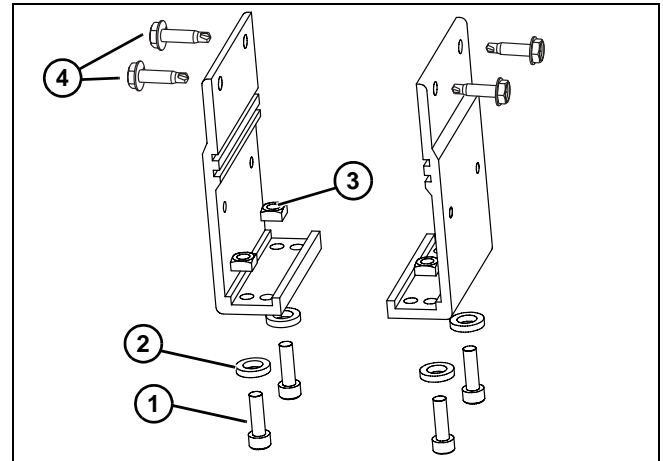

Figure 9

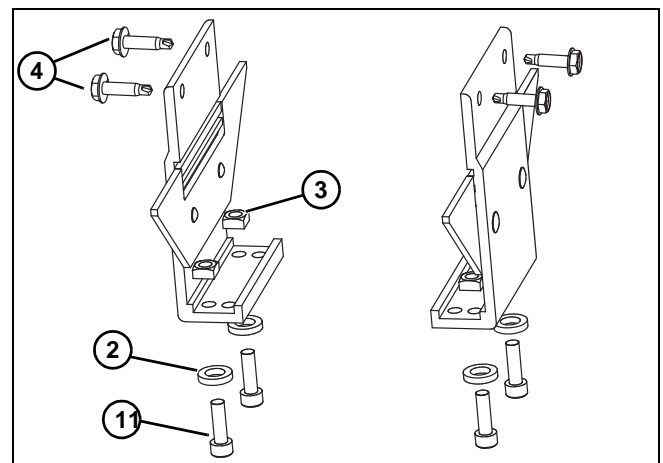

Figure 10

2. Remove screws (Figure 9, item 1) or (Figure 10, item 1), washers (Figure 9, item 2) or (Figure 10, item 2), nuts (Figure 9, item 3) or (Figure 10, item 3) from brackets.

IMPORTANT

For proper methods of attachment to conveyor side rail for 2300 series see page 15.

3. Locate and retain self-drilling screws (Figure 9, item 4) or (Figure 10, item 4).

NOTE

For maximum support distance see page 5.

Installation

4. Measure an equal distance (**Figure 11, item 1**) from end of head plate (on both sides of conveyor) and mark placement of mounting brackets (**Figure 11, item 2**). Fasten mounting brackets to conveyor with mounting screws (**Figure 11, item 3**) following proper methods of attachment instructions on page 10.

NOTE

Mounting brackets for flat belt conveyors shown.

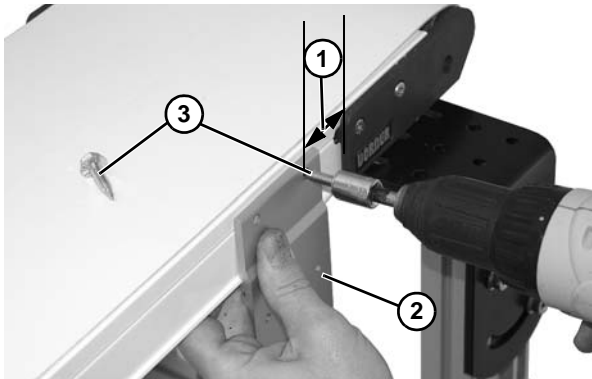

Figure 11

5. Fasten brackets (**Figure 12, item 1**) to support stand (**Figure 12, item 2**) with mounting screws (**Figure 12, item 3**), washers (**Figure 12, item 4**) and nuts (**Figure 12, item 5**).

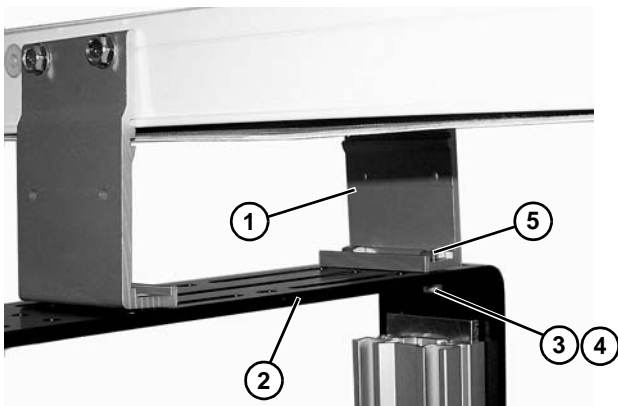

Figure 12

Return Rollers

Cleated Belt and 2 - 6" (51 - 152 mm) Wide Flat Belt Conveyors

1. Locate return rollers. Exploded views shown in Figure 13 and Figure 14.

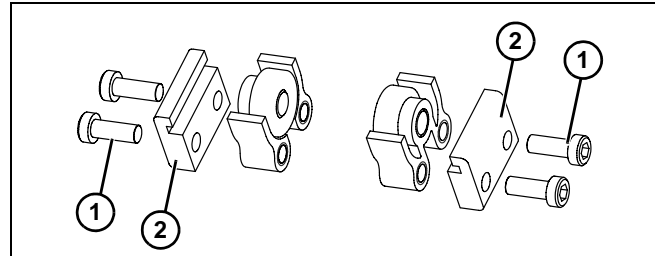

Figure 13

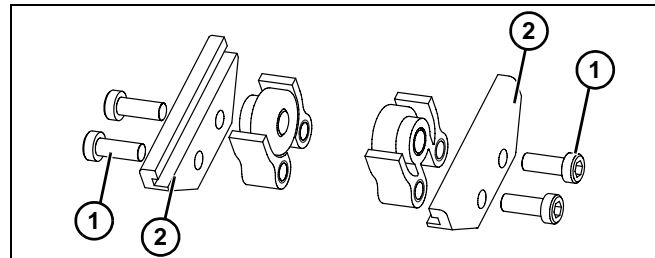

Figure 14

2. Remove screws (**Figure 13, item 1**) or (**Figure 14, item 1**) and clips (**Figure 13, item 2**) or (**Figure 14, item 2**) from roller assembly.
3. Install roller assemblies (**Figure 15, item 1**) as shown. Tighten screws (**Figure 15, item 2**) to 60 in-lb (7 Nm).

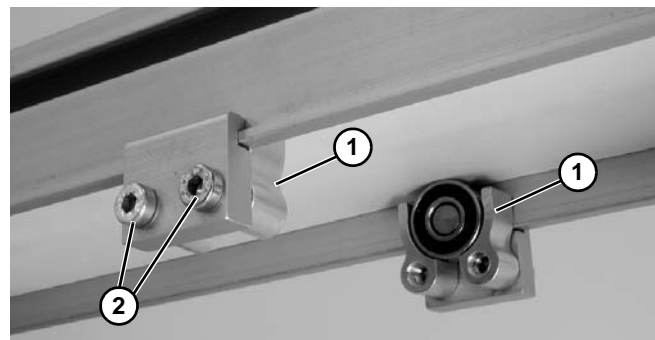

Figure 15

8 - 18" (203 - 457 mm) Wide Flat Belt Conveyors

1. Locate return rollers. Exploded view shown in Figure 16.

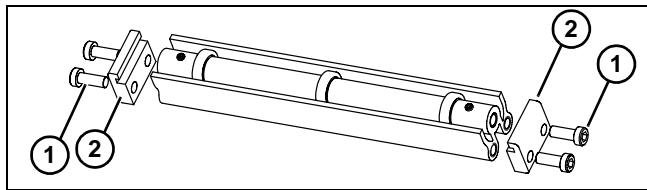

Figure 16

2. Remove screws (Figure 16, item 1) and clips (Figure 16, item 2) from roller assembly.
3. Install roller assembly as shown (Figure 17, item 1). Tighten screws (Figure 17, item 1) to 60 in-lb (7 Nm).

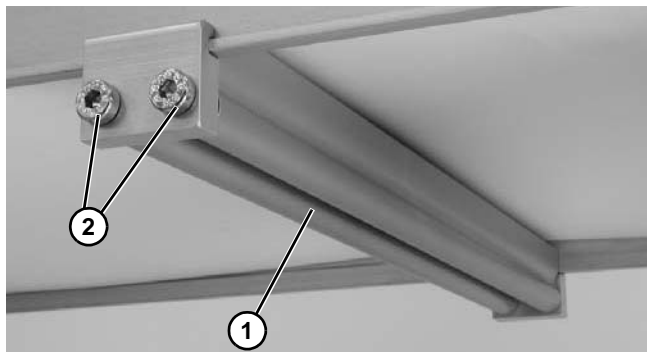

Figure 17

Proper Methods of Attachment to Side Rails (2300 Series Only)

⚠ WARNING

Installing self-drilling screws into the dustpruf side rail requires substantial force.

Failure to properly support the conveyor while installing self-drilling screws may cause the operator or conveyor to slip, causing severe injury.

SUPPORT CONVEYOR FRAMES WHILE INSTALLING SELF-DRILLING SCREWS.

The 2300 DustPruf side rail is designed for self-drilling attachment of brackets and accessories. This can be done in two methods: self-drilling screws or pre-drill for standard screws.

Self-Drilling Screws

All Dorner accessories are provided with 1/4-20 self-drilling screws.

1. Locate and hold bracket (Figure 18, item 1) to side rail. Hole should line up with notch (Figure 18, item 2) in side rail.

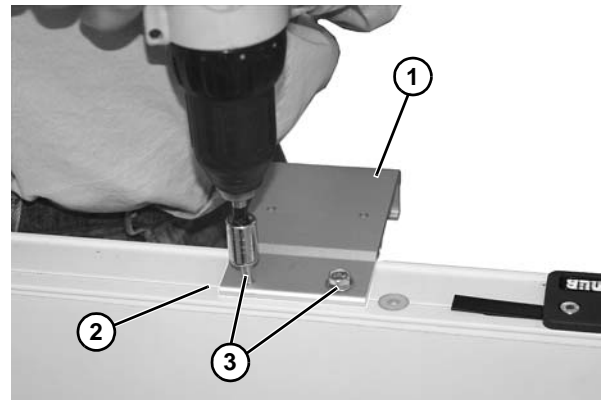

Figure 18

2. With a cordless drill or equivalent install self-drilling screws (Figure 18, item 3). Use high speed setting to drill through side wall. Once the tap portion is started switch drill power to a lower speed. Do not fully tighten with drill.
3. Hand tighten the screws to secure (Figure 19). Recommended torque is 150 in.lbs (17 Nm).



Figure 19

Installation

Pre-Drill for Standard Screws

The DustPruf side rail will also accept standard screws. M6-1.0 and 1/4-20 are acceptable. Strength grade 8 is recommended.

1. Locate and hold bracket (**Figure 20, item 1**) to side rail. Hole should line up with notch (**Figure 20, item 2**) in side rail. Mark the hole locations with a center punch (**Figure 20, item 3**) and remove the bracket.

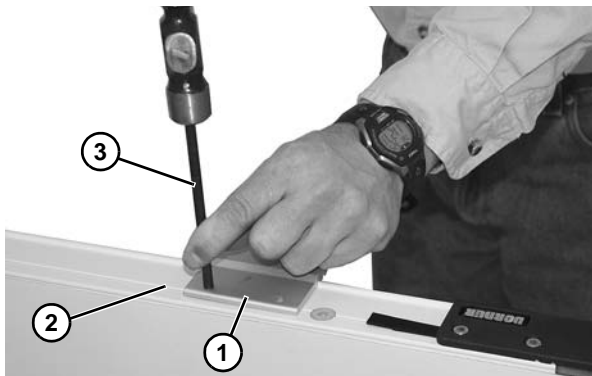

Figure 20

2. Drill the hole locations (**Figure 21, item 1**) with a 3/16" drill bit (**Figure 21, item 2**).

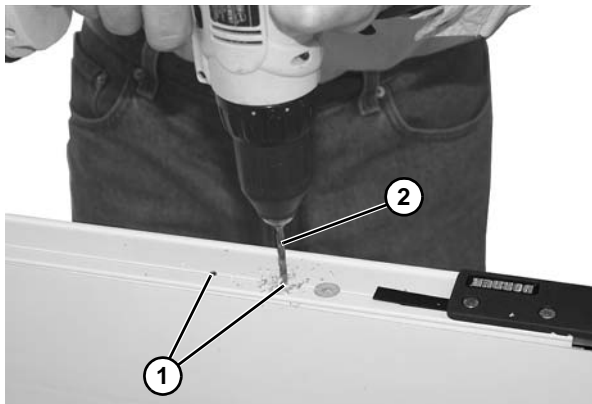

Figure 21

3. Position and hold bracket (**Figure 22, item 1**) to side rail. With a standard M6-1.0 or 1/4-20 screw, install screws (**Figure 22, item 2**) with cordless drill or equivalent. Do not fully tighten with drill.

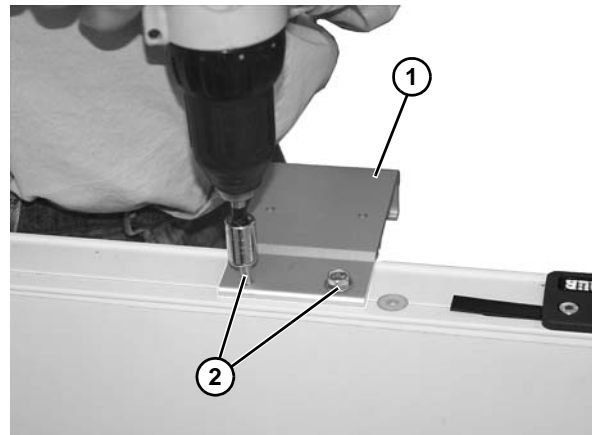

Figure 22

4. Hand tighten the screws to secure (**Figure 23**). Recommended torque is 150 in.lbs (17 Nm).



Figure 23

Guiding (2300 Series Only)

⚠ WARNING

Installing self-drilling screws into the DustPruf side rail requires substantial force.

Failure to properly support the conveyor while installing self-drilling screws may cause the operator or conveyor to slip, causing severe injury.

SUPPORT CONVEYOR FRAMES WHILE INSTALLING SELF-DRILLING SCREWS.

Due to the DustPruf construction ALL guiding must be located and installed by the end user. Take care in locating retaining clips prior to final installation.

1. Lay out retaining clip (**Figure 24, item 1**) locations. The end clips should be no greater than 12" (**Figure 24, item 2**) from end of the conveyor.

NOTE

Profile -09, Low to High Side shown below. For other guide profile layouts see pages page 36 thru page 46.

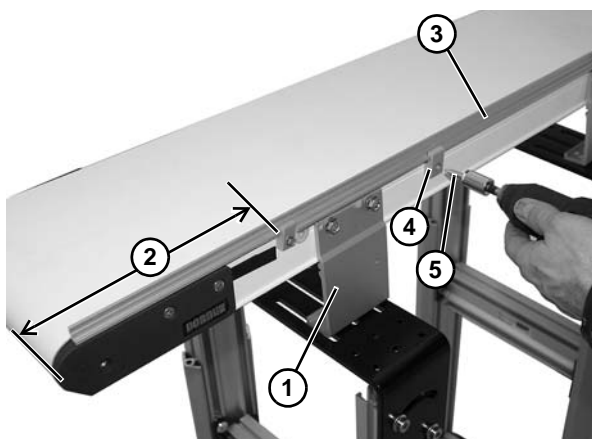

Figure 24

2. Hold guide (**Figure 24, item 3**) and retaining clips (**Figure 24, item 4**) to conveyor side rail. Install self-drilling screws (**Figure 24, item 5**) following the "Proper Methods of Attachment to Side Rails (2300 Series Only)" on page 15 procedure.

Wiring

⚠ WARNING



Motor will start immediately once power is supplied. Exposed moving parts can cause severe injury. LOCK OUT POWER before wiring to avoid accidental startup.

The 2200 and 2300 series iDrive is available in 3 models:

- A. Cover Mounted Controls*
- B. Cover Mounted Controls with Remote Start/Stop Cable*
- C. Customer Wired Controls with Flying Leads

*Both options A and B are available with AC power supply or customer supplied power supply.

Cover Mounted Controls with 115 volt Power Supply

1. No wiring is required. Attach quick disconnect end of power supply (**Figure 25, item 1**) to power jack (**Figure 25, item 2**).

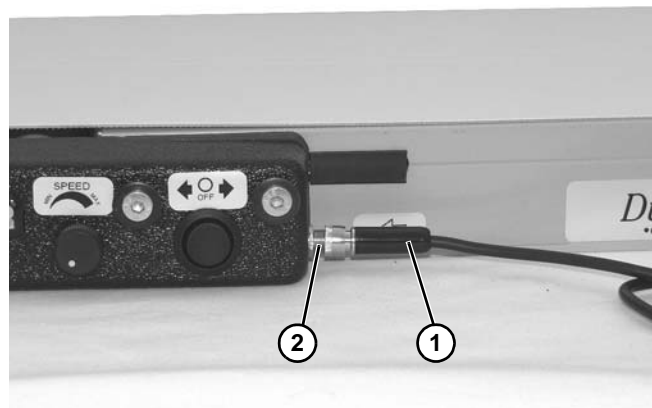

Figure 25

Installation

Cover Mounted Controls with Customer Provided Power Supply

1. Locate the male disconnect plug (Figure 27, item 1) provided.



Figure 26

2. Wire and solder DC power to the two terminals of the provided DC power plug. Wire +VDC to the short lug (Figure 27, item 1) and -VDC to the long lug (Figure 27, item 2).

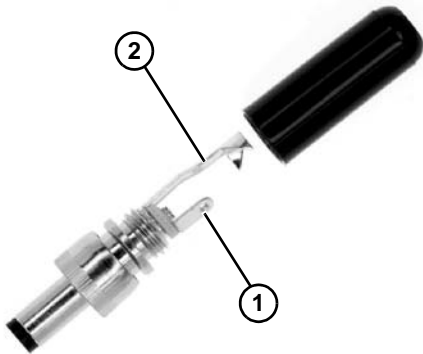

Figure 27

3. Required power is 24VDC, 2 amps minimum.

Cover Mounted Controls

1. Connect power supply to cover. See page 17.
2. Select conveyor running direction with directional switch (Figure 28, item 1).

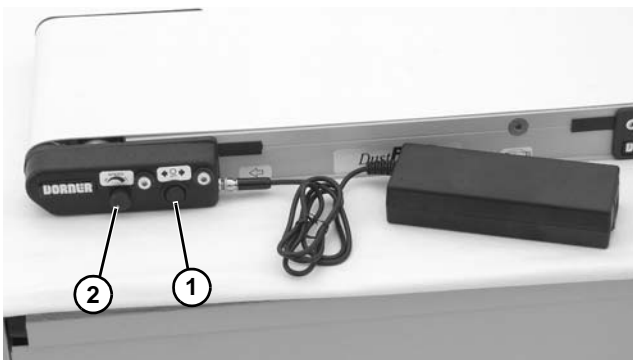

Figure 28

3. Select conveyor speed with speed control knob (Figure 28, item 2).

NOTE

1. *Start Stop Application: Maximum start stop cycles are 30 per minute.*
2. *Reversing Applications: Do not reverse the motor direction when running. Make sure the motor is stopped before reversing signal is given.*

Cover Mounted Controls with Remote Start/Stop Cable

1. Connect power supply to cover. See page 18.
2. Select conveyor running direction with directional switch (Figure 29, item 1).

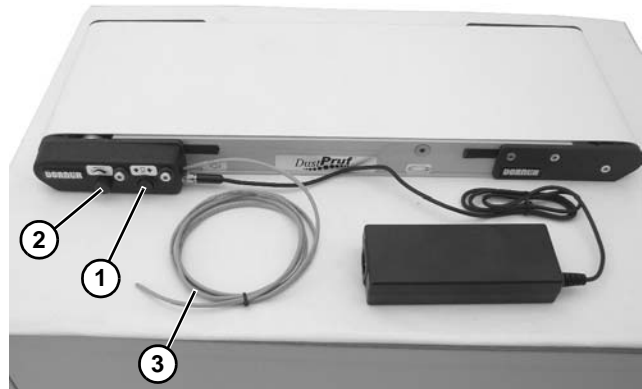

Figure 29

3. Select conveyor speed with speed control knob (Figure 29, item 2).
4. Remote start/stop cable (Figure 29, item 3) comes with wire nut over remote leads to allow test running conveyor.
5. Remove wire nut and connect red and black wires to switching device. Switching device minimum rating 1 amp @ 24 VDC.

NOTE

1. *Start Stop Application: Maximum start stop cycles are 30 per minute.*
2. *Reversing Applications: Do not reverse the motor direction when running. Make sure the motor is stopped before reversing signal is given.*

Cover Mounted Controls with Photo Eye Option

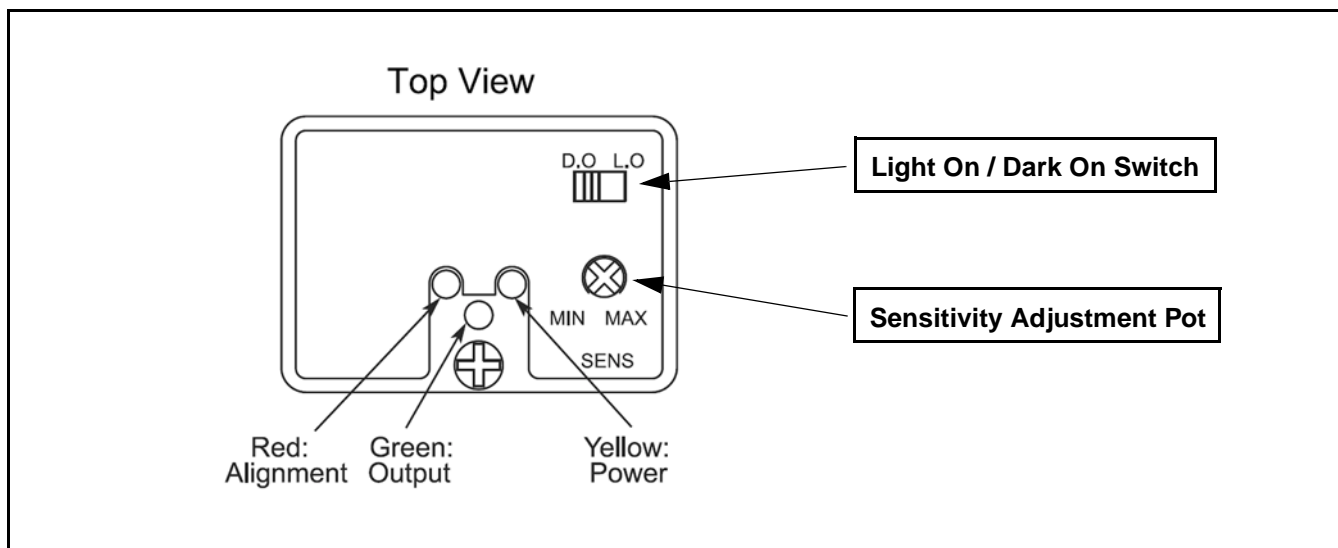

Figure 30

1. Mount photo eye and reflector bracket to side of conveyor close to zone to be sensed.
2. Connect power supply to AC input power, photo eye plug, and to conveyor drive cover. Adjust conveyor running direction switch to off (center) position. Photo eye should have yellow LED lit.
3. Adjust reflector to align with red beam emitted from photo eye and be at a 90 degree +/- 15 degree angle to photo eye face. When reflector is properly aligned, photo eye will have yellow and red LED lit. Green LED indicates output relay is energized.
4. Adjust photo eye sensitivity by placing a sample object in the beam. Unscrew clear cover on photo eye top and slowly turn the gain adjustment clockwise (see caution below concerning pot adjustment) until the green (output) LED activates (assuming the sensor is in the light operate mode). Note the position and remove the sample object. Now continue turning the sensitivity setting clockwise to find the position where the green LED activates from the background reflection. Reset the sensitivity midway between the two positions.
5. Photo eye comes preset to Light-On operation which causes the conveyor to run when the sensed zone is clear and stop when the sensed zone is blocked. For Dark-On operation move selector to D.O. position (**Figure 30**).
6. Select conveyor running direction with directional switch (**Figure 28, item 1**). If Dark-On operation is selected, temporarily block photo eye to energize conveyor.
7. Select conveyor speed with speed control knob (**Figure 28, item 2**).

CAUTION

Adjustment pots are 3/4 turn devices. Any resistance encountered while adjusting these pots indicates you have reached the adjustment limit stop. Turning past stop will damage the sensor.

Installation

Customer Wired Controls with Flying Leads

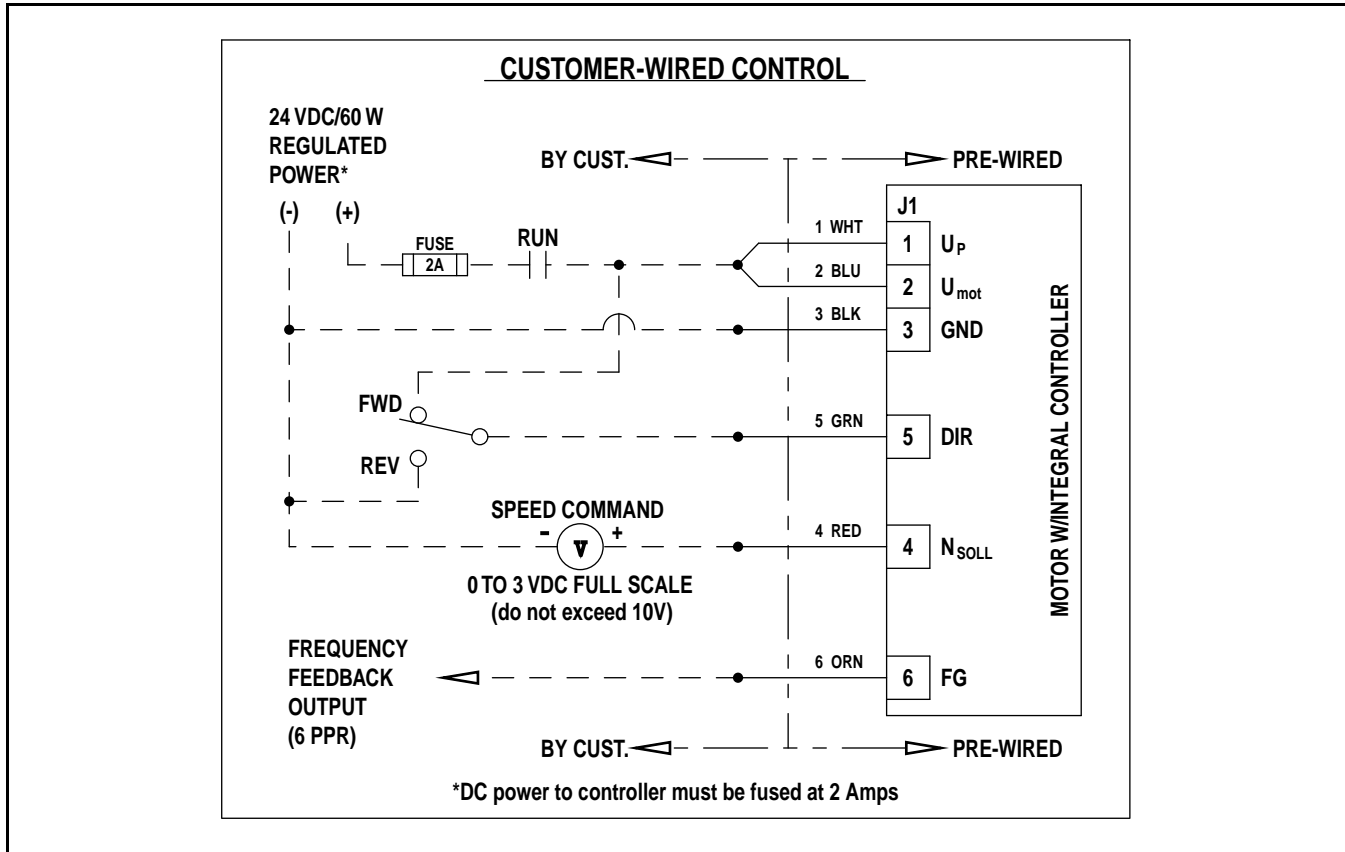

Figure 31

NOTE

1. Start Stop Application: Maximum start stop cycles are 30 per minute.
2. Reversing Applications: Do not reverse the motor direction when running. Make sure the motor is stopped before reversing signal is given.

1. Locate lead wires (Figure 32, item 1) extending from iDrive cover. Determine wiring diagrams based on diagrams above (Figure 31).

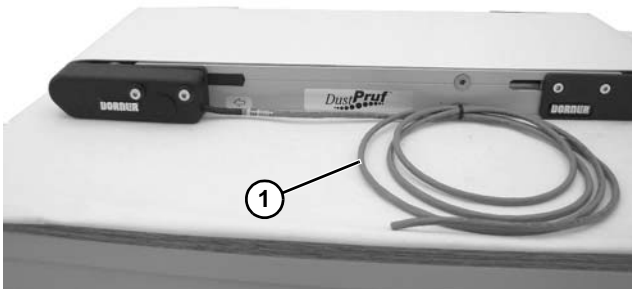

Figure 32

Preventive Maintenance and Adjustment

Required Tools

Standard Tools

- Hex-key wrenches:
2.5 mm, 4 mm, 5 mm, 5/64 in.
- Arbor press
- T20 Torque Wrench

Special Tools

- 807-1716 Bearing Puller Tool (or equivalent)
- 450293 Bearing Installation Tool (Bearing Pusher)
- 456063 Bearing Removal Tool

Checklist

- Keep service parts on hand (see “Service Parts” section for recommendations)
- Keep supply of belt cleaner (part # 625619)
- Clean entire conveyor and knurled spindle while disassembled
- Replace worn or damaged parts

Lubrication

No lubrication is required. Replace bearings if worn.

Maintaining Conveyor Belt

Troubleshooting

Inspect conveyor belt for:

- Surface cuts or wear
- Stalling or slipping
- Damage to V-guide

Surface cuts and wear indicate:

- Sharp or heavy parts impacting belt
- Jammed parts
- Improperly installed bottom wipers (if installed)
- Accumulated dirt in wipers (if installed)
- Foreign material inside the conveyor
- Improperly positioned accessories
- Bolt-on guiding is pinching belt

Stalling or slipping indicates:

- Excessive load on belt
- Conveyor belt or drive timing belt are not properly tensioned
- Worn knurl or impacted dirt on drive spindle
- Intermittent jamming or drive train problems

Damage to V-guide indicates:

- Twisted or damaged conveyor frame
- Dirt impacted on spindles
- Excessive or improper side loading

Cleaning

IMPORTANT

Do not use belt cleaners that contain alcohol, acetone, Methyl Ethyl Ketone (MEK) or other harsh chemicals.

Use Dorner Belt Cleaner (part # 625619). Mild soap and water may also be used. Do not soak the belt.

For /05 woven polyester and /06 black anti-static belts, use a bristled brush to improve cleaning.

Conveyor Belt Replacement

WARNING



Exposed moving parts can cause severe injury. LOCK OUT POWER before removing guards or performing maintenance.

Conveyor Belt Replacement Sequence

- Remove old conveyor belt
- Install new conveyor belt
- Tension conveyor belt

Belt Removal

1. Place temporary support stands (**Figure 33, item 1**) at both ends of the conveyor.

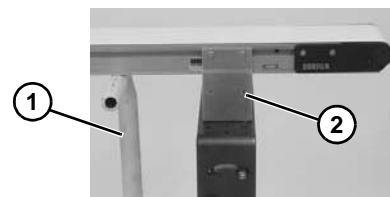

Figure 33

2. Remove mounting brackets (**Figure 33, item 2**) from one side of conveyor. (Reverse steps 3 & 4 of “Mounting Brackets” section beginning on page 12.)

Preventive Maintenance and Adjustment

3. If equipped, remove bottom wipers (**Figure 34, item 1**): Remove fastening screws (**Figure 34, item 2**) then remove wiper (**Figure 34, item 1**).

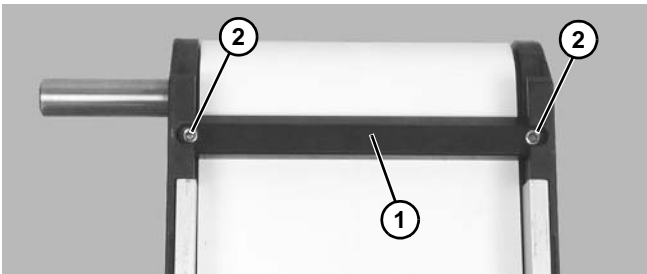



Figure 34

4. On tension end of the conveyor, identified with a  label (**Figure 35, item 1**), push in head plate assembly (**Figure 35, item 2**): On both sides of conveyor, loosen and move cam tracking assemblies (**Figure 35, item 3**) (if equipped) away from head plates, then loosen fastening screws (**Figure 35, item 4**) and push head plate assembly inward.

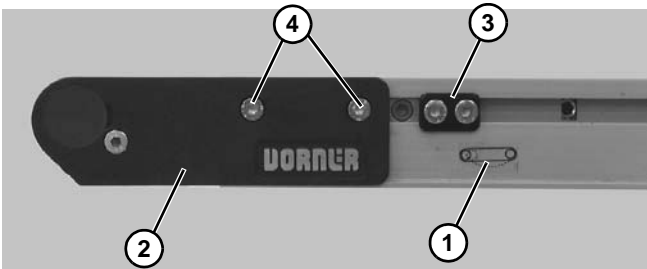

Figure 35

5. Remove belt (**Figure 36, item 1**) from conveyor.

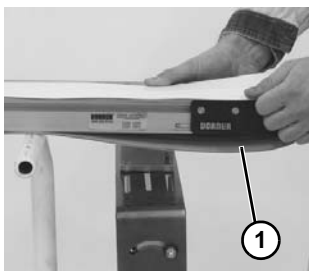

Figure 36

Belt Installation

1. Ensure temporary support stands (**Figure 33, item 1**) are placed at both ends of the conveyor.
2. Orient belt so splice leading fingers (**Figure 37, item 1**) point in the direction of belt travel as identified by the conveyor directional label (**Figure 37, item 2**).

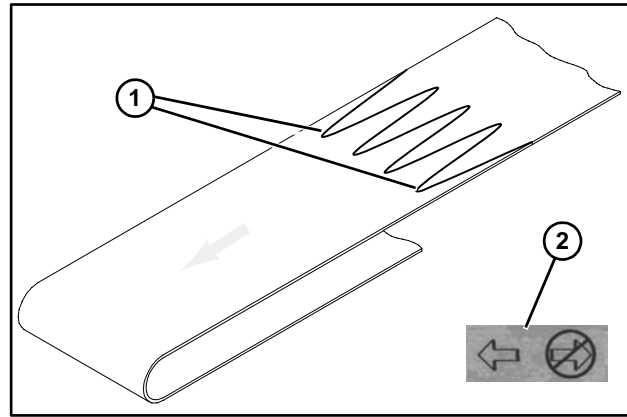

Figure 37

3. Install belt (**Figure 38, item 1**) on conveyor. Lift conveyor slightly to avoid pinching belt on temporary support stands.

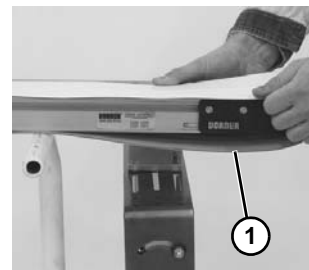



Figure 38

4. Re-install conveyor mounting brackets. Refer “Mounting Brackets” beginning on page 12, steps 3 through 5.
5. Tension belt. Refer to “Conveyor Belt Tensioning” on page 23
6. If equipped, re-install wipers, return rollers and guiding.

Preventive Maintenance and Adjustment

Conveyor Belt Tensioning

⚠ WARNING

Exposed moving parts can cause severe injury. LOCK OUT POWER before removing guards or performing maintenance.

NOTE
<i>Tension belt with minimum tension to keep belt from slipping. On pinion gear, do not exceed a torque of 15 in-lb (1.6 Nm). Over tensioning the conveyor belt could cause reduced load capacity, excessive pulley bearing load, and early failure.</i>

- After adjusting proper tensioning, tighten fastening screws (**Figure 41, item 1**) on both sides of conveyor to 60 in-lb (7 Nm).

Conveyors with 1.25" (32 mm) Diameter Pulleys

- On tension end of the conveyor, identified with a  label (**Figure 39, item 1**), adjust head plate assembly (**Figure 39, item 2**): On both sides of conveyor, loosen fastening screws (**Figure 39, item 3**) and rotate pinion gear (**Figure 39, item 4**) to adjust head plate assembly.

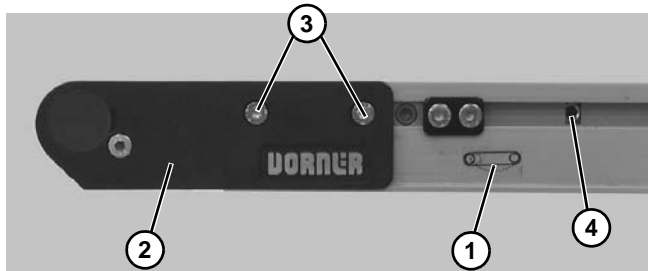

Figure 39

- Adjust head plate assembly so end of conveyor frame aligns with or between the head plate tensioning marks (**Figure 40, item 1 and 2**). Replace belt if proper tensioning can not be obtained while aligning the end of the conveyor frame with or between the tensioning marks. See NOTE.



Figure 40

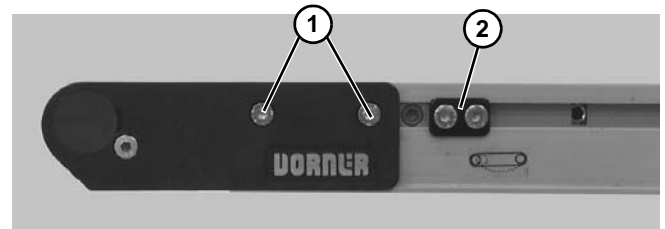



Figure 41

- If equipped with cam tracking assemblies (**Figure 41, item 2**), position against head plates and adjust belt tracking. Refer to "Conveyor Belt Tracking" on page 24.

Conveyors with Nose Bar Idlers

- On tension end of the conveyor, identified with a  label (**Figure 42, item 1**), adjust head plate assembly (**Figure 42, item 2**): On both sides of conveyor, loosen fastening screws (**Figure 42, item 3**) and rotate pinion gear (**Figure 42, item 4**) to adjust head plate assembly.

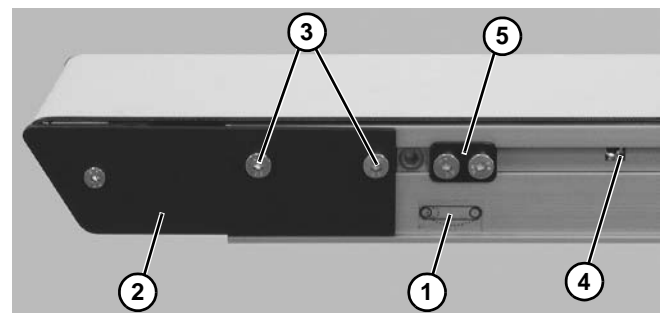

Figure 42

Preventive Maintenance and Adjustment

- Adjust head plate assembly so the edge of the axle support plate (**Figure 43, item 1**) is separated from the end of the conveyor (**Figure 43, item 2**) by 1.125" (29 mm) (**Figure 43, item 3**). Replace belt if proper tensioning can not be obtained within a distance of 1.50" (38 mm). See NOTE.

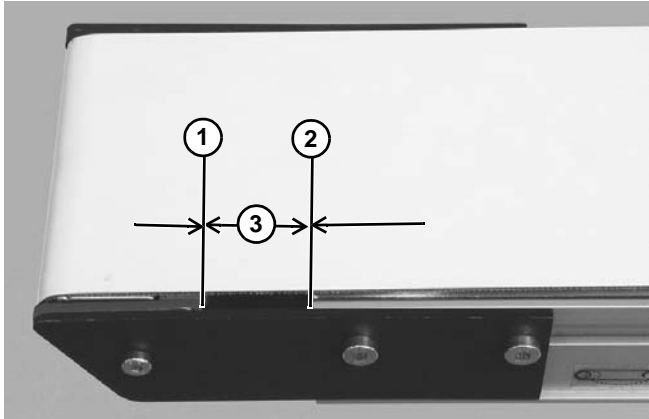

Figure 43

NOTE

Tension belt with minimum tension to keep belt from slipping. On pinion gear, do not exceed a torque of 15 in-lb (1.6 Nm). Over tensioning the conveyor belt could cause reduced load capacity, excessive pulley bearing load, and early failure.

- After adjusting proper tensioning, tighten fastening screws (**Figure 42, item 3**) on both sides of conveyor to 60 in-lb (7 Nm).
- If equipped with cam tracking assemblies (**Figure 42, item 5**) position against head plates and adjust belt tracking. Refer to "Conveyor Belt Tracking", next section.

Conveyor Belt Tracking

V-Guided Belts

V-guided belts do not require tracking adjustment.

Non V-Guided Belts

Non V-guided belt conveyors are equipped with belt tracking cam assemblies (**Figure 44, item 1**) for belt tracking adjustment.

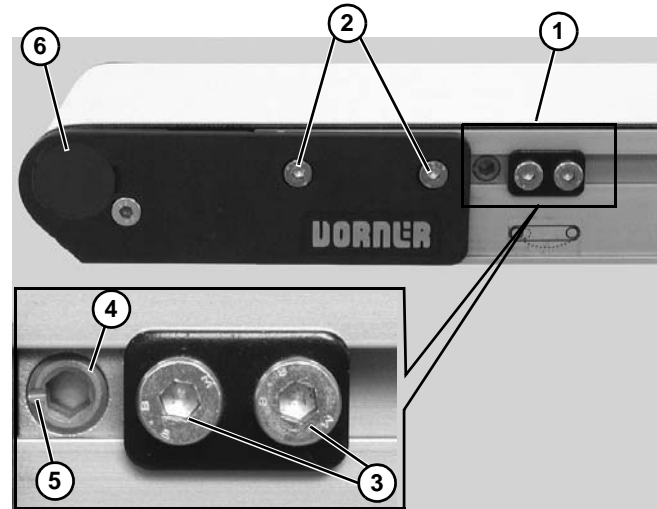



Figure 44

When adjusting belt tracking, always adjust the discharge end of the conveyor first. To adjust belt tracking:

- Ensure head plate fastening screws (**Figure 44, item 2**) on both sides of conveyor are tightened.
- On both sides of conveyor, loosen two (2) cam fastening screws (**Figure 44, item 3**). Adjust cams (**Figure 44, item 4**) until indicator slots (**Figure 44, item 5**) are horizontal and facing end of conveyor. Then slide cam assemblies against head plates (**Figure 44, item 6**) and re-tighten cam fastening screws (**Figure 44, item 3**) to 60 in-lb (7 Nm).
- On the side toward which the belt is tracking, loosen head plate fastening screws (**Figure 44, item 2**).
- With the conveyor running, use a 5 mm hex-key wrench to rotate the tracking cam (**Figure 44, item 4**) in small increments until the belt tracks in the center of the conveyor. Then while holding the cam in position, re-tighten the head plate fastening screws (**Figure 44, item 2**) with a 4 mm hex-key wrench to 60 in-lb (7 Nm).

Preventive Maintenance and Adjustment

Spindle Removal

⚠ WARNING

Exposed moving parts can cause severe injury. LOCK OUT POWER before removing guards or performing maintenance.

- A – Idler Spindle Removal
- B – Drive Spindle Removal

A – Idler Spindle Removal

NOTE
<i>To prevent damage to the head plates and spindle, be sure to remove them slowly because they are not attached to spindle.</i>

1. On one side of the conveyor, loosen two (2) head plate fastening screws (**Figure 45, item 1**) and remove them.



Figure 45

2. Remove the head plate (**Figure 46, item 1**) from the conveyor frame.

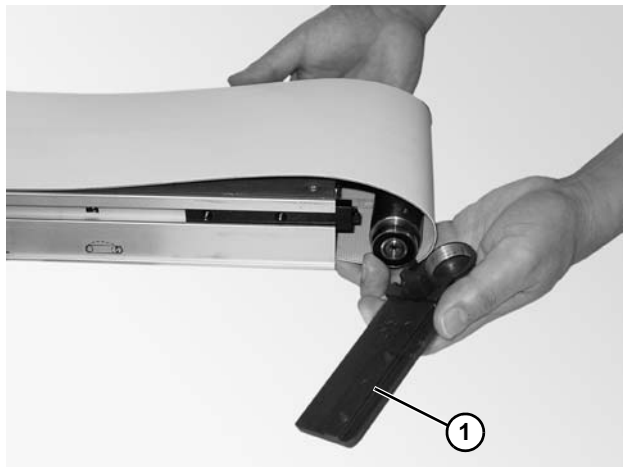

Figure 46

3. Spindle will slide out of opposite head plate and drop into slack of belt (**Figure 47**).



Figure 47

4. Slide spindle out of the belt loop.

B – Drive Spindle Removal

NOTE
<i>To prevent damage to the head plates and spindle, be sure to remove them slowly because they are not attached to spindle.</i>

1. Remove belt. (See “Belt Removal” on page 21.)
2. Remove inframe drive side cover (**Figure 48, item 1**) by removing two iDrive cover screws (**Figure 48, item 2**).

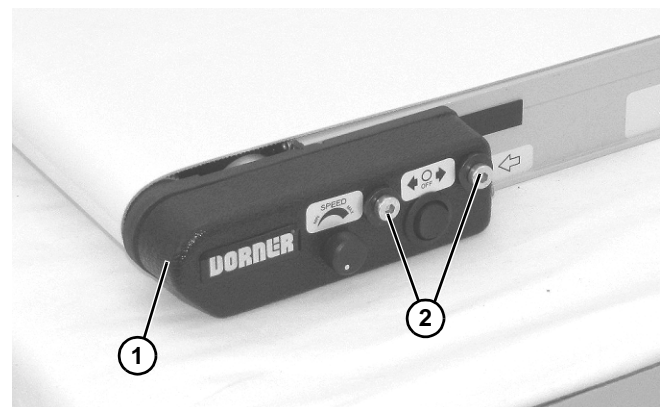

Figure 48

Preventive Maintenance and Adjustment

- Unplug motor connector (Figure 48, item 1) from cover wiring connector (Figure 48, item 2).

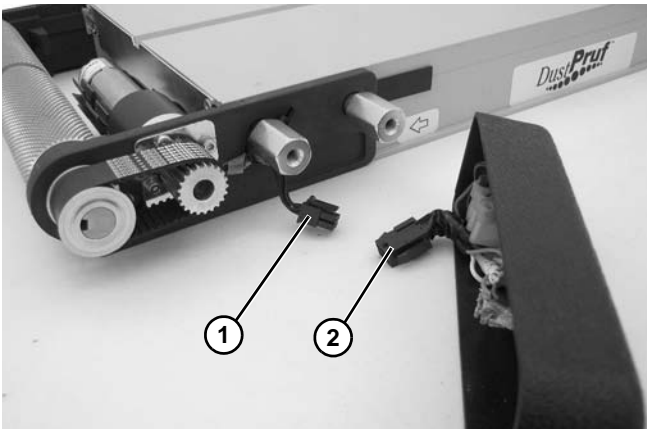

Figure 49

- Loosen four clamp plate screws (Figure 50, item 1).

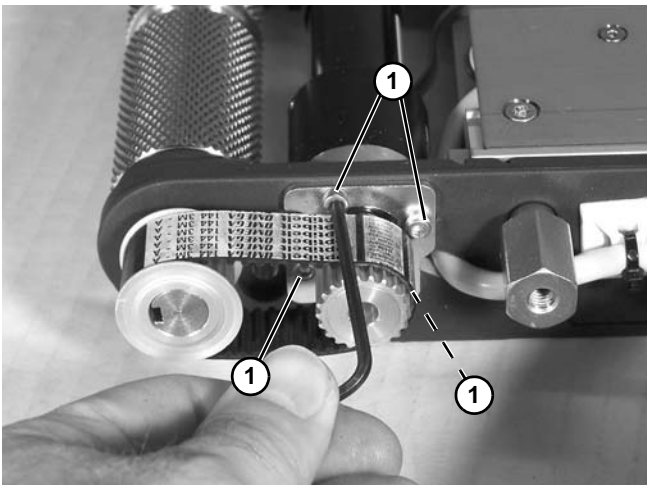

Figure 50

- Loosen timing belt tension cam (Figure 51, item 1).

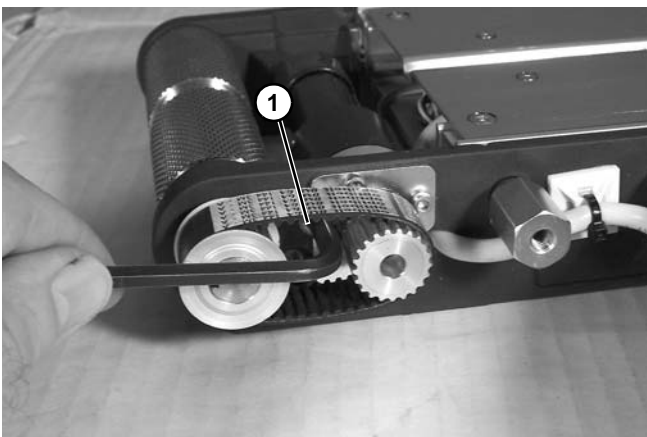

Figure 51

- Loosen two set screws (Figure 52, item 1) on drive pulley (Figure 52, item 2). Slide drive pulley outward off of the gearmotor shaft, and remove timing belt (Figure 52, item 3).

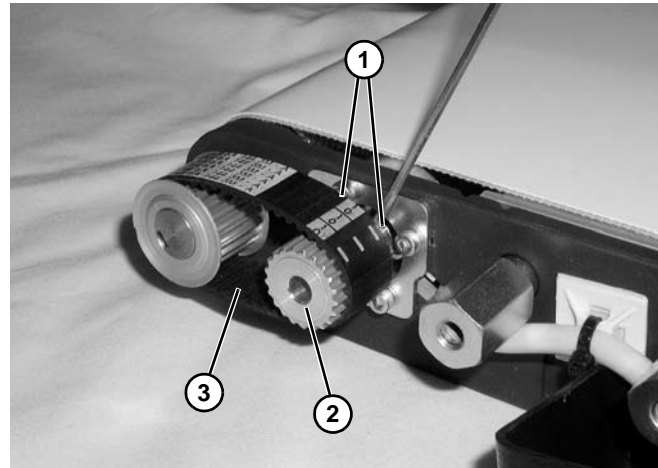

Figure 52

⚠ WARNING

Drive shaft keyway may be sharp. HANDLE WITH CARE.

- Loosen two set screws (Figure 53, item 1) on driven pulley (Figure 53, item 2), and slide off of shaft to remove.

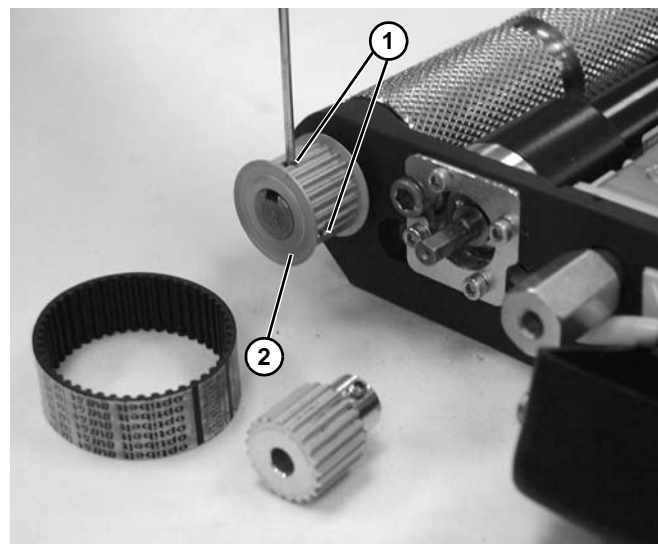

Figure 53

- Remove driven pulley (Figure 53, item 2).

Preventive Maintenance and Adjustment

9. Remove two head plate fastening screws (Figure 54, item 1) from opposite side of conveyor.

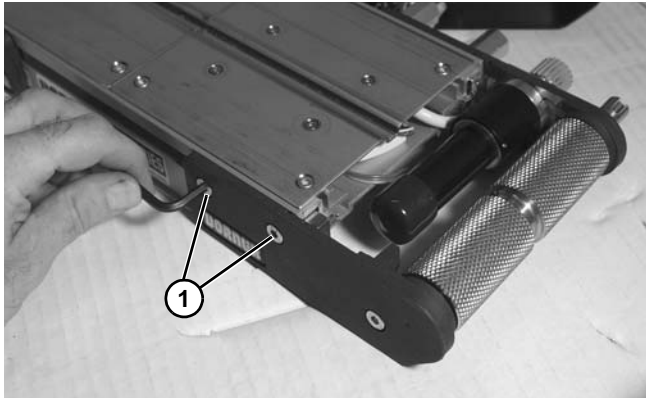

Figure 54

CAUTION
Spindle can slide out.

10. Remove head plate (Figure 55, item 1) from frame.

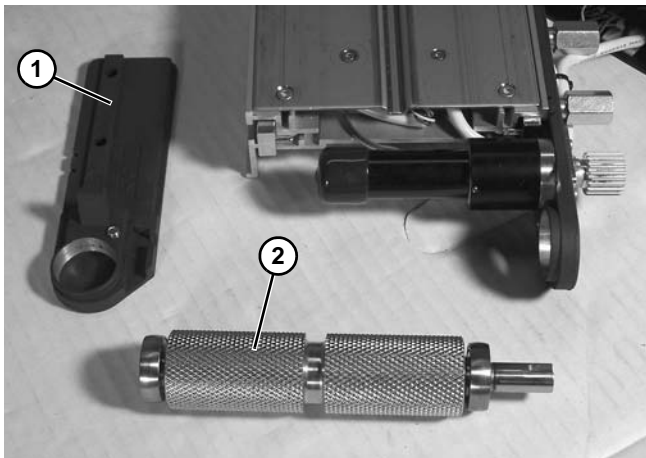

Figure 55

11. Replace spindle (Figure 55, item 2).

Bearing Removal & Replacement

Removal

IMPORTANT

Do not use any removed bearings. Replace them.

1. Place bearing removal tool part #456063 (Figure 56, item 1) below bearing (Figure 56, item 2) with lip (Figure 56, item 3) located in gap (Figure 56, item 4) between bearing and spindle hub (Figure 56, item 5) as shown.

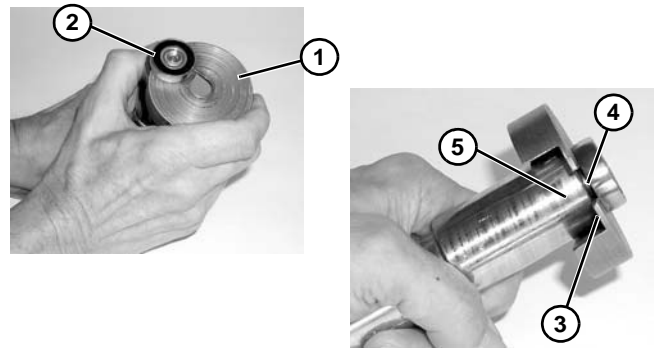

Figure 56

2. Using puller part #807-1716 (Figure 57, item 1), remove and discard bearing.

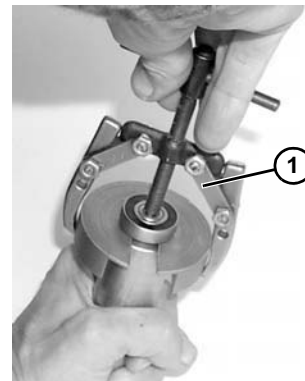

Figure 57

Preventive Maintenance and Adjustment

Replacement

1. Inspect the head plates bearing seating surface (**Figure 58, item 1**). If they are worn or damaged, replace. See “Service Parts” on page 32.

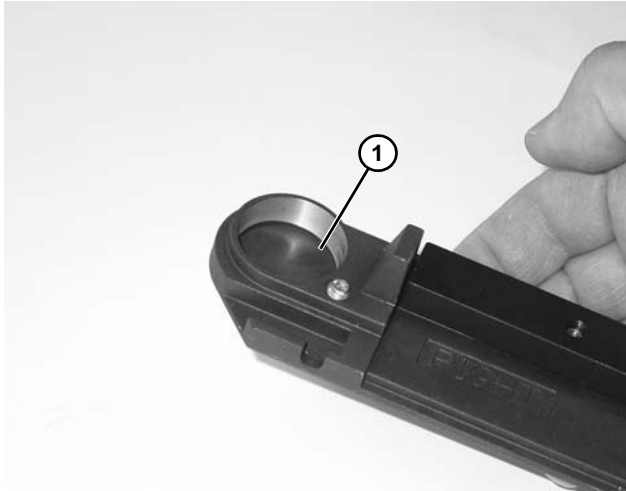

Figure 58

2. Inspect spindle (**Figure 59, item 1**). Replace if worn.
3. Slide bearing (**Figure 59, item 2**) onto spindle.

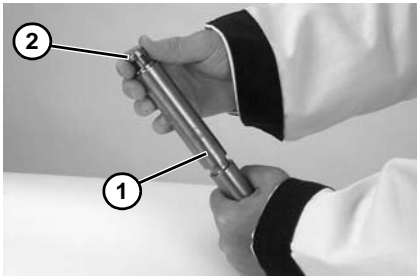

Figure 59

4. Using an arbor press or similar device, press bearing onto pulley shaft (**Figure 60**).

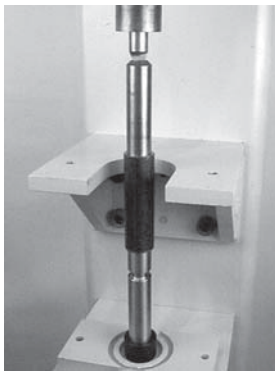

Figure 60

5. Repeat steps 1 through 4 for each bearing.

Spindle Installation

Idler Spindle Installation

1. With opposite head plate installed, position the idler spindle (**Figure 61, item 1**) through the loop of the belt, into the opposite head plate.

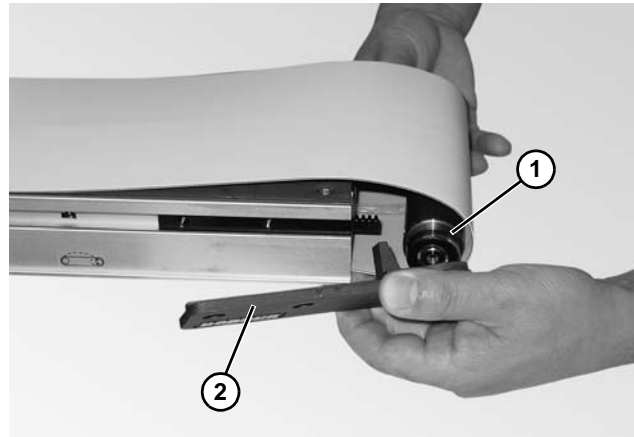

Figure 61

2. Place the head plate (**Figure 61, item 2**) and attach the head plate to the conveyor frame with the two (2) screws removed and hand tighten.

Drive Spindle Installation

1. Install drive spindle (**Figure 62, item 1**) into head plate (**Figure 62, item 2**). Install head plate (**Figure 62, item 3**) and install screws (**Figure 62, item 4**).

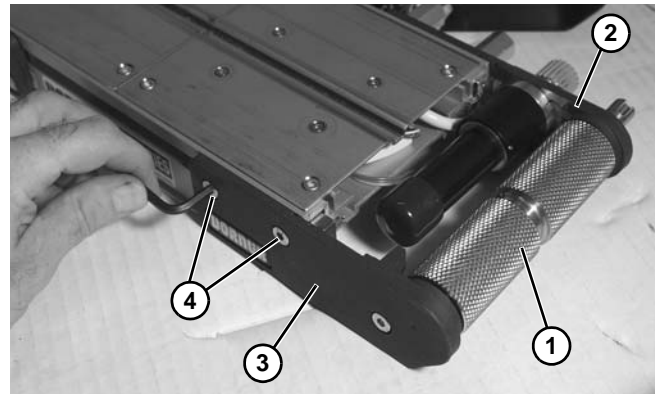

Figure 62

⚠ WARNING



Drive shaft keyway may be sharp. HANDLE WITH CARE.

Preventive Maintenance and Adjustment

2. Install driven pulley (Figure 63, item 1) onto conveyor shaft until flush with spindle end. Line up longer set screw (Figure 63, item 2) on pulley over keyway (Figure 63, item 3) of shaft. Tighten set screw (Figure 63, item 2) and set screw (Figure 63, item 4) to 18 in-lb (7 Nm).

CAUTION

Failure to install the longer set screw into the keyway will cause the setscrew to protrude into the timing belt, which will cause the conveyor to run erratically and may cause damage to the timing belt and the gearmotor shaft.

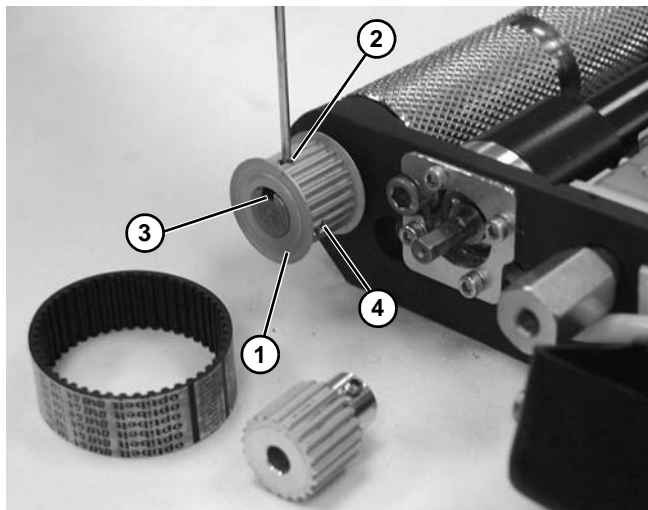

Figure 63

3. Slip timing belt (Figure 64, item 1) over driven pulley (Figure 64, item 2) and slide drive pulley (Figure 64, item 3) through timing belt onto gearmotor shaft.

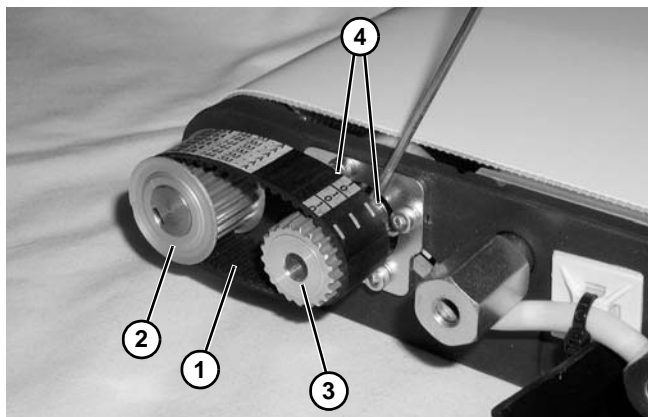

Figure 64

4. Tighten drive pulley set screws (Figure 64, item 4) on gearhead shaft, making sure one set screw is over flat on shaft, and drive pulley is aligned with driven pulley.

5. Tighten timing belt tension cam (Figure 65, item 1), making certain that pointer (Figure 65, item 2) on cam is pointing towards the motor drive spindle (Figure 65, item 3).

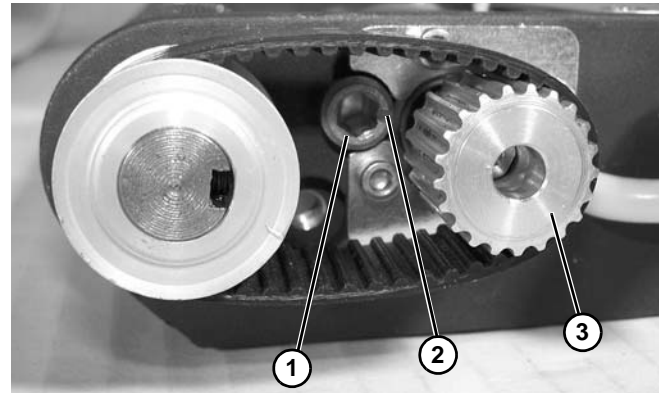

Figure 65

6. Rotate tension cam (Figure 65, item 1) to obtain 1/8 - 1/4" belt deflection at center of belt (Figure 66, item 1) with approximately 3-5 in-lb of pressure. Tighten four clamp plate screws (Figure 66, item 2) to 15 in-lb (1.6 Nm) to secure position.

CAUTION

Over tightening of timing belt will result in reduced gearmotor and timing belt life.

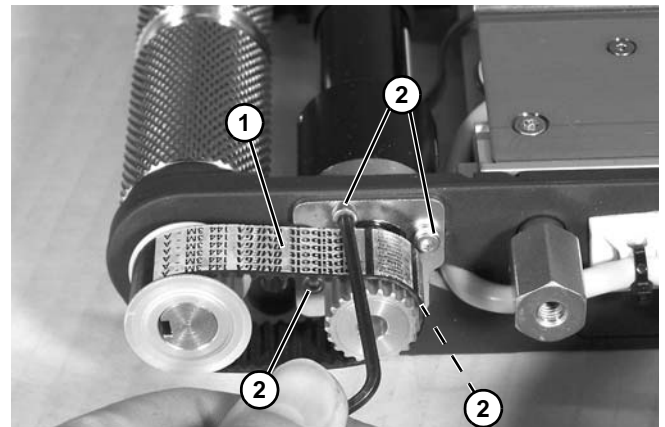

Figure 66

7. Install inframe drive side cover (Figure 67, item 1) with two head plate fastening screws (Figure 67, item 2).

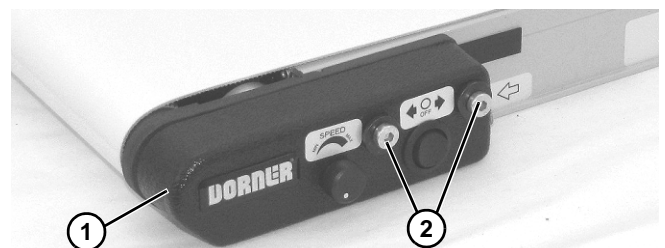

Figure 67

Preventive Maintenance and Adjustment

Nose Bar Roller Replacement

1. On both sides of conveyor, use a 4 mm hex-key wrench to loosen cam fastening screws (**Figure 68, item 1**) and slide cam assemblies toward the center of the conveyor.

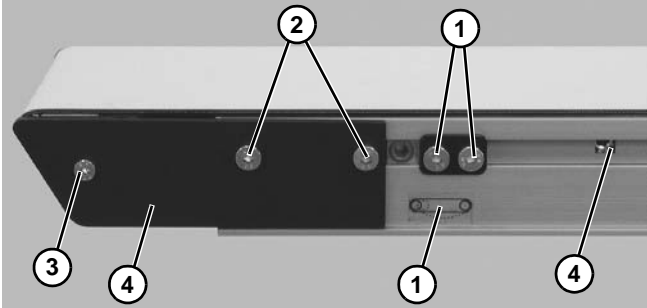

Figure 68

2. On both sides of conveyor, use a 4 mm hex-key wrench to loosen head plate fastening screws (**Figure 68, item 2**) to remove belt tension. Then remove belt from end of conveyor.
3. On one side of conveyor, use a 3 mm and 4 mm hex-key wrench to remove head plate fastening screws (**Figure 68, item 3**) and (**Figure 68, item 2**) and remove head plate (**Figure 68, item 4**).
4. Slide nose bar rods (**Figure 69, item 1**) out side of conveyor and replace rollers (**Figure 69, item 2**) as necessary.

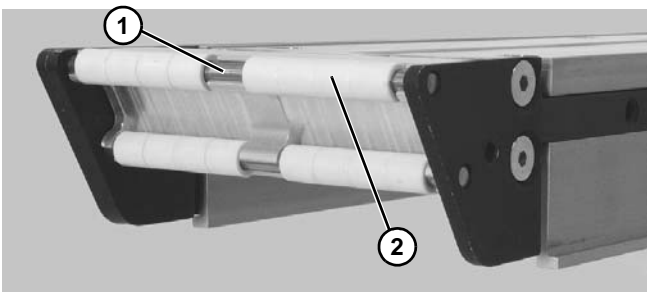

Figure 69

5. After replacing rollers, re-install head plate (**Figure 68, item 4**). Use a 3 mm hex-key wrench to tighten one (1) fastening screw (**Figure 68, item 3**) to 30 in-lb (3.4 Nm). Leave two (2) fastening screws (**Figure 68, item 2**) loose for belt tensioning.
6. Re-install belt on end of conveyor, then tension the belt. See “Conveyor Belt Tensioning” on page 23.
7. Re-position the cam assemblies against the head plates and adjust belt tracking. See “Conveyor Belt Tracking” on page 24.

Motor Removal and Replacement

1. Remove belt. (See “Belt Installation” on page 22.)
2. Remove inframe drive side cover (**Figure 70, item 1**) by removing two head plate fastening screws (**Figure 70, item 2**).

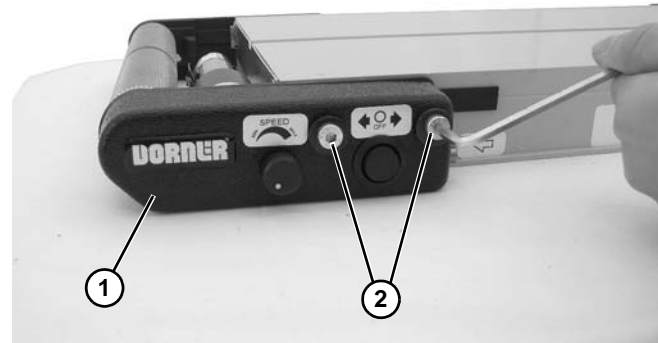

Figure 70

3. Unplug motor connector (**Figure 71, item 1**) from cover wiring connector (**Figure 71, item 2**), and cut cable tie (**Figure 71, item 3**) from conveyor.

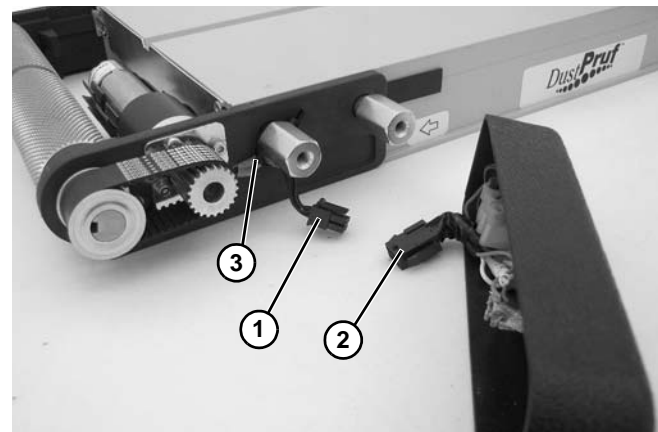

Figure 71

4. Loosen four clamp plate screws (**Figure 72, item 1**).

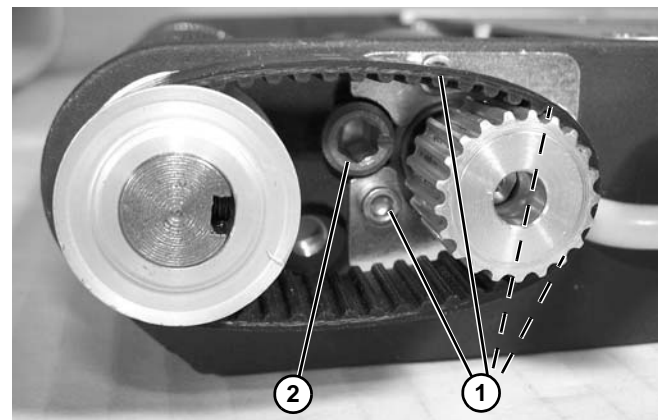

Figure 72

5. Loosen timing belt tension cam (**Figure 72, item 2**).

Preventive Maintenance and Adjustment

- Loosen two set screws (**Figure 73, item 1**) on drive pulley (**Figure 73, item 2**). Slide drive pulley outward off of gearmotor shaft and remove timing belt (**Figure 73, item 3**).

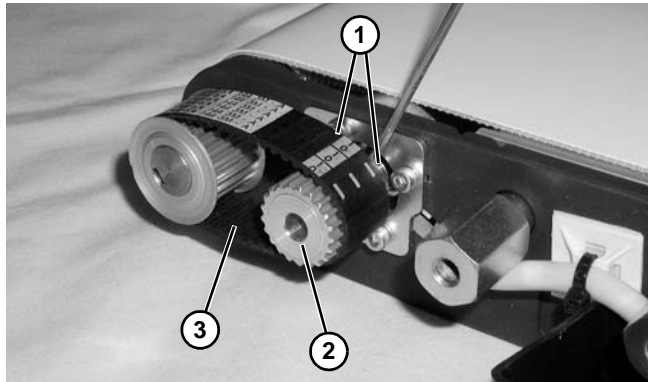

Figure 73

- Remove four clamp plate screws (**Figure 74, item 1**) and clamp plate (**Figure 74, item 2**).

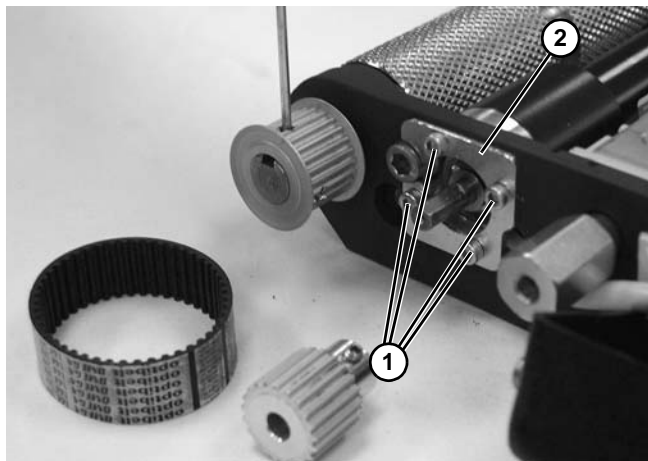

Figure 74

- Remove motor (**Figure 75, item 1**).

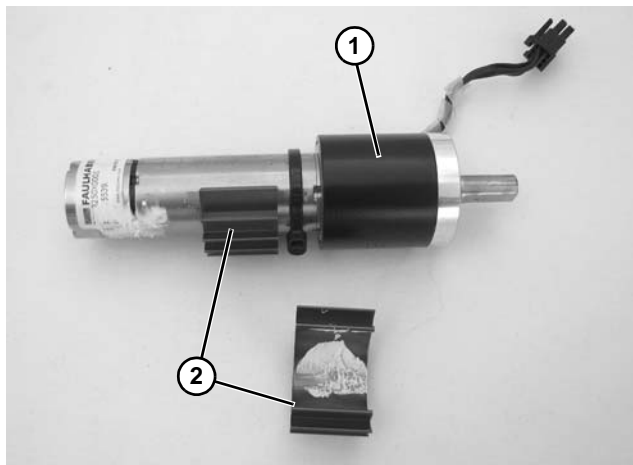

Figure 75

- Snap off heat sinks (**Figure 75, item 2**).

NOTE

When reassembling, make sure the pointer on the timing belt tension cam is pointing towards the motor.

- Replace motor.
- Add heat sink compound to heat sinks (**Figure 76, item 1**) before reinstalling to motor.

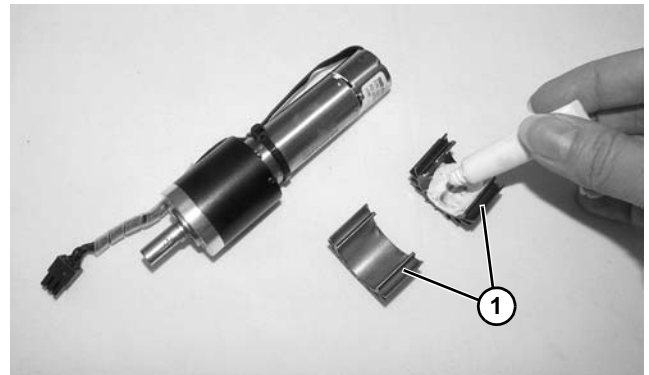

Figure 76

- Reinstall in reverse order of removal. (Refer to “Drive Spindle Installation” on page 28 for timing belt tensioning.)

NOTE

*Place heat sinks (**Figure 77, item 1**) on bottom side of motor, avoiding the v-guide path (**Figure 77, item 2**).*

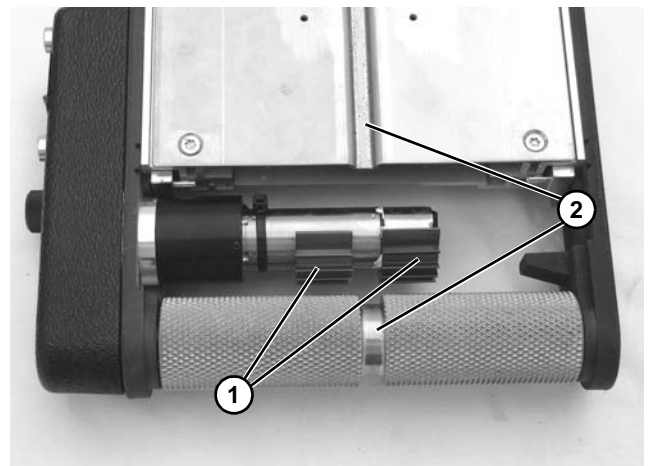



Figure 77

Service Parts

NOTE

For replacement parts other than those shown in this section, contact an authorized Dorner Service Center or the factory. Key Service Parts and Kits are identified by the Performance Parts Kits logo . Dorner recommends keeping these parts on hand.

Drive End

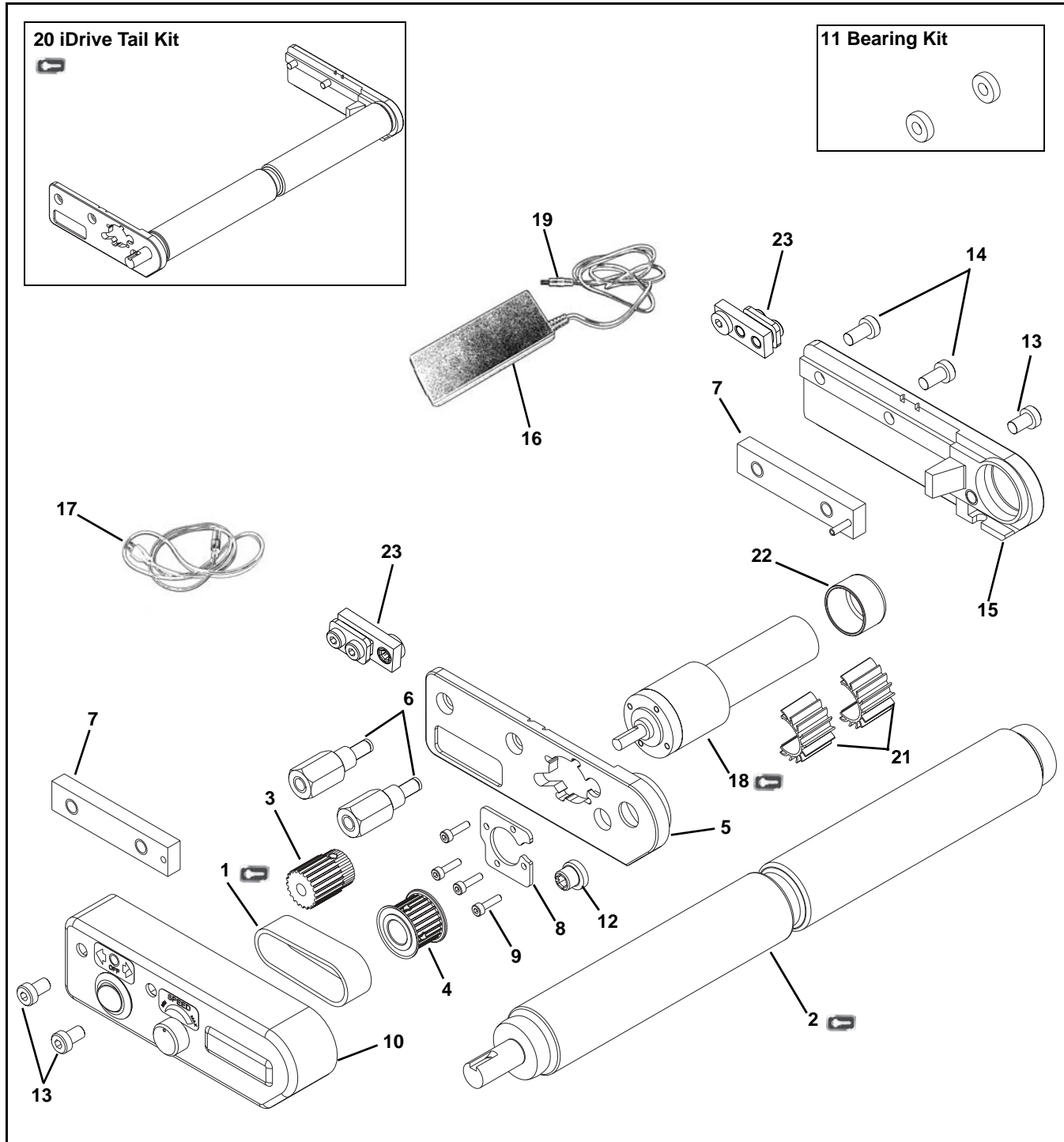

Service Parts

Item	Part Number	Description
1	814-145	Timing Belt, 3 mm x 48 teeth
2	201272- <u>WW</u>	Knurled Spindle with Bearings
	201278- <u>WW</u>	Lagged Spindle with Bearings (for use with Nose Bar Idler Tail)
3	201330	Drive Pulley - 17 Tooth
	201331	Drive Pulley - 21 Tooth
4	203203	Driven Pulley - 24 Tooth
	203204	Driven Pulley - 28 Tooth
5	201016F	Head Plate, A position
	201018F	Head Plate, D position (shown)
6	201020	Hex Standoff
7	201180	Tension Slide Bar (2200 Series)
	205806-LH	Tension Slide Bar, Left Hand (2300 Series)
	205806-RH	Tension Slide Bar, Right Hand (2300 Series)
8	201181	Clamp Plate
9	920312M	Socket Head Screw, M3-.50 x 12 mm
10	22FDEAA	Electrical Assembly, with speed direction control for A position
	22FDEAD	Electrical Assembly, with speed direction control for D position
	22FDC6A	Electrical Assembly, with customer wired control for A position, 6' cable
	22FDC6D	Electrical Assembly, with customer wired control for D position, 6' cable
	22FDC30A	Electrical Assembly, with customer wired control for A position, 30' cable
	22FDC30D	Electrical Assembly, with customer wired control for D position, 30' cable
	22FDR6A	Electrical Assembly, with speed, direction, and 6' remote start/stop cable for A position
	22FDR6D	Electrical Assembly, with speed, direction, and 6' remote start/stop cable for D position
	22FDR30A	Electrical Assembly, with speed, direction, and 30' remote start/stop cable for A position
	22FDR30D	Electrical Assembly, with speed, direction, and 30' remote start/stop cable for D position

Item	Part Number	Description
11	22BK2	Bearing Kit (2 pack)
	22BK4	Bearing Kit (4 pack)
12	200039P	Timing Belt Tension Cam
13	920691M	Low Head Cap Screw, M6-1.00 x 10 mm
14	920692M	Low Head Cap Screw, M6-1.00 x 12 mm
15	201321	Non-Drive Head Plate, for 2"- 4" wide D position
	201322	Non-Drive Head Plate, for 2"- 4" wide A position
	203208	Non-Drive Head Plate, for 5" wide D position
	203209	Non-Drive Head Plate, for 5" wide A position
	240425F	Non-Drive Head Plate, for 6" wide and wider D position (shown)
	240426F	Non-Drive Head Plate, for 6" wide and wider A position
16	831-139	Power Supply
17	818-164	Cord, 115V
18	22FDGM023	Gearmotor, 23:1
	22FDGM066	Gearmotor, 66:1
19	805-1316	Plug
20	22AF- <u>WW</u>	iDrive Tail Kit for A position with Knurled Spindle (Includes Items 3, 6, 17 and 18)
	22DF- <u>WW</u>	iDrive Tail Kit for D position with Knurled Spindle (Includes Items 3, 6, 17 and 18)
	22NAF- <u>WW</u>	iDrive Tail Kit for A position with Lagged Spindle (Includes Items 3, 6, 17 and 18)
	22NDF- <u>WW20</u>	iDrive Tail Kit for D position with Lagged Spindle (Includes Items 3, 6, 17 and 18)
21	807-1982	Heat Sink
22	807-2006	Motor Cap, for 2"-3" wide
23	240025	Cam Mount Assembly (2200 Series)
	712029	Cam Mount Assembly (2300 Series)
<u>WW</u> = Conveyor width reference: 02, 03, 04, 05, 06, 08, 10, 12 & 18		

Service Parts

Idler End

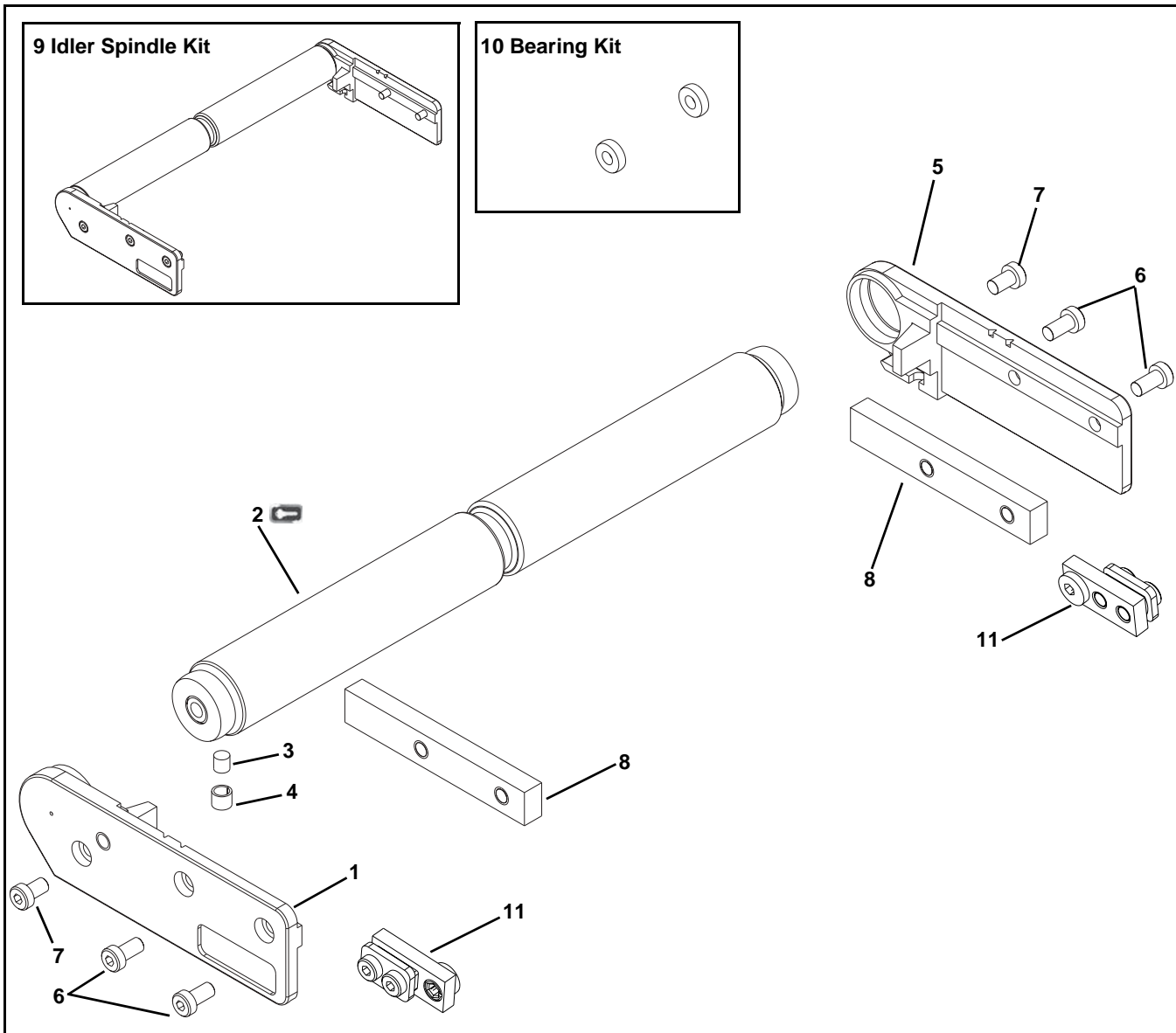

Item	Part Number	Description
1	240425	Head Plate, Left Hand
2	201273- <u>WW</u>	Spindle Kit with Bearings
3	808-020	Magnet, 0.25" diameter x 0.25" long
4	450226SSP	Sleeve
5	240426	Head Plate, Right Hand
6	920692M	Socket Head Screw, M6 x 12 mm
7	920691M	Socket Head Screw, M6 x 10 mm

Item	Part Number	Description
8	240329	Tension Slide Bar (2200 Series)
	712016	Tension Slide Bar (2300 Series)
9	22T- <u>WW</u>	Idler Spindle Kit, (Includes Items 1 through 7)
10	22BK2	Bearing Kit (2 pack)
	22BK4	Bearing Kit (4 pack)
11	240025	Cam Mount Assembly (2200 Series)
	712029	Cam Mount Assembly (2300 Series)

WW = Conveyor width reference: 02, 03, 04, 05, 06, 08, 10, 12 & 18

Nose Bar Idler End

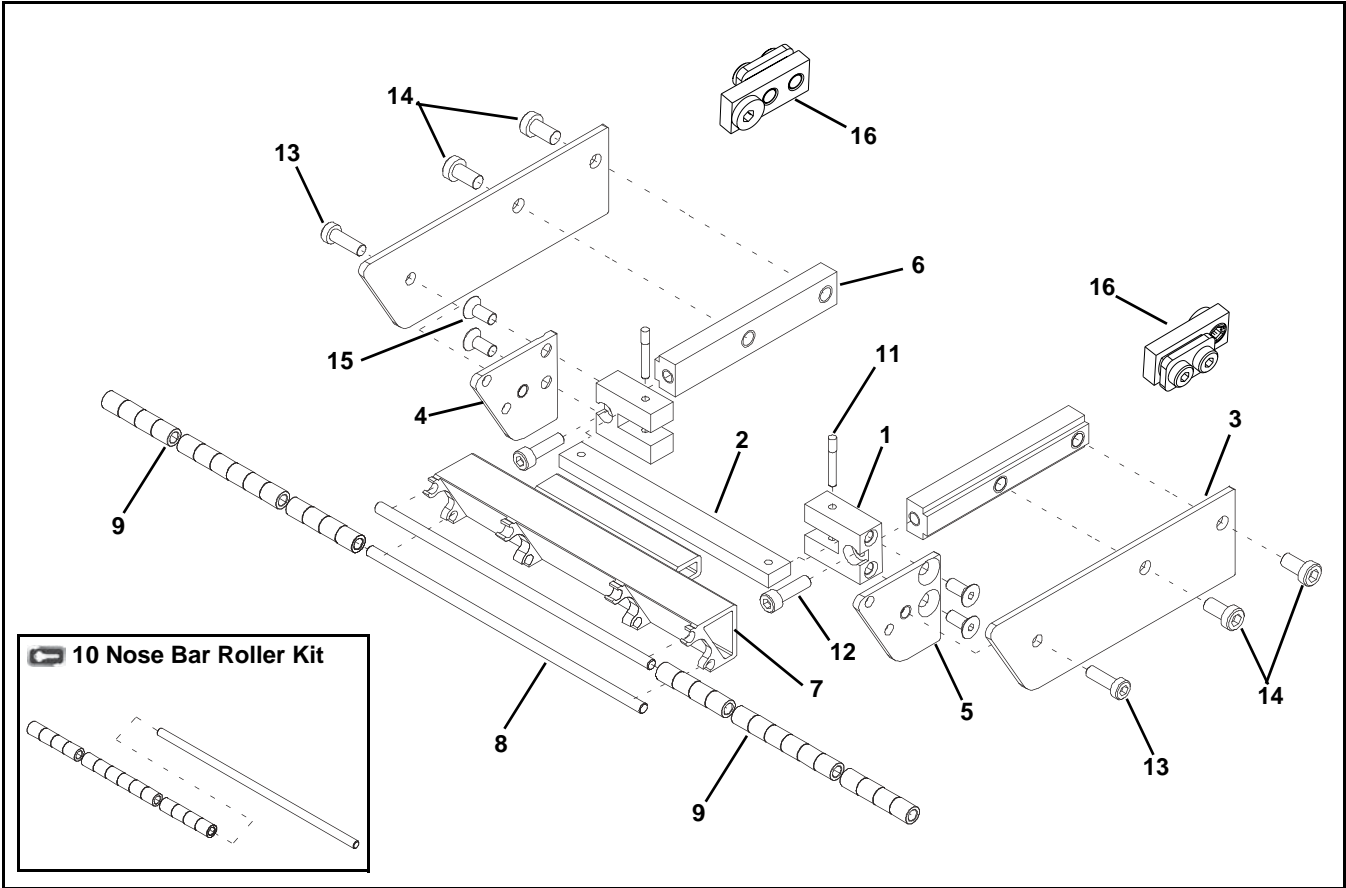

Item	Part Number	Description
1	201965M	Mounting Block, PLT Spindle
2	2076 WW	Flex-Link Bar
3	241125	Outer Side Plate
4	241126	Inner Side Plate LH
5	241127	Inner Side Plate RH
6	241128	Head Plate Bar (2200 Series)
	712052	Head Plate Bar (2300 Series)
7	2412 WW	Nose Bar
8	2413 WW	Nose Bar Rod
9	801-122	Nose Bar Roller
10	22N- WW	Nose Bar Roller Kit (Includes Items 8 and 10)
11	200695P	Knurl Pin 0.125" DIA x 0.937" Lg
12	920518M	Socket Head Screw, M5 x 18 mm
13	920593M	Socket Head Screw, M5 x 16 mm
14	920692M	Socket Head Screw, M6 x 12 mm
15	930512M	Flat Head Screw, M5 x 12 mm
16	240025	Cam Mount Assembly (2200 Series)
	712029	Cam Mount Assembly (2300 Series)

~~WW~~ = Conveyor width reference: 02, 03, 04, 05, 06, 08, 10, 12 & 18

Service Parts

-04 3" (76 mm) Aluminum Side

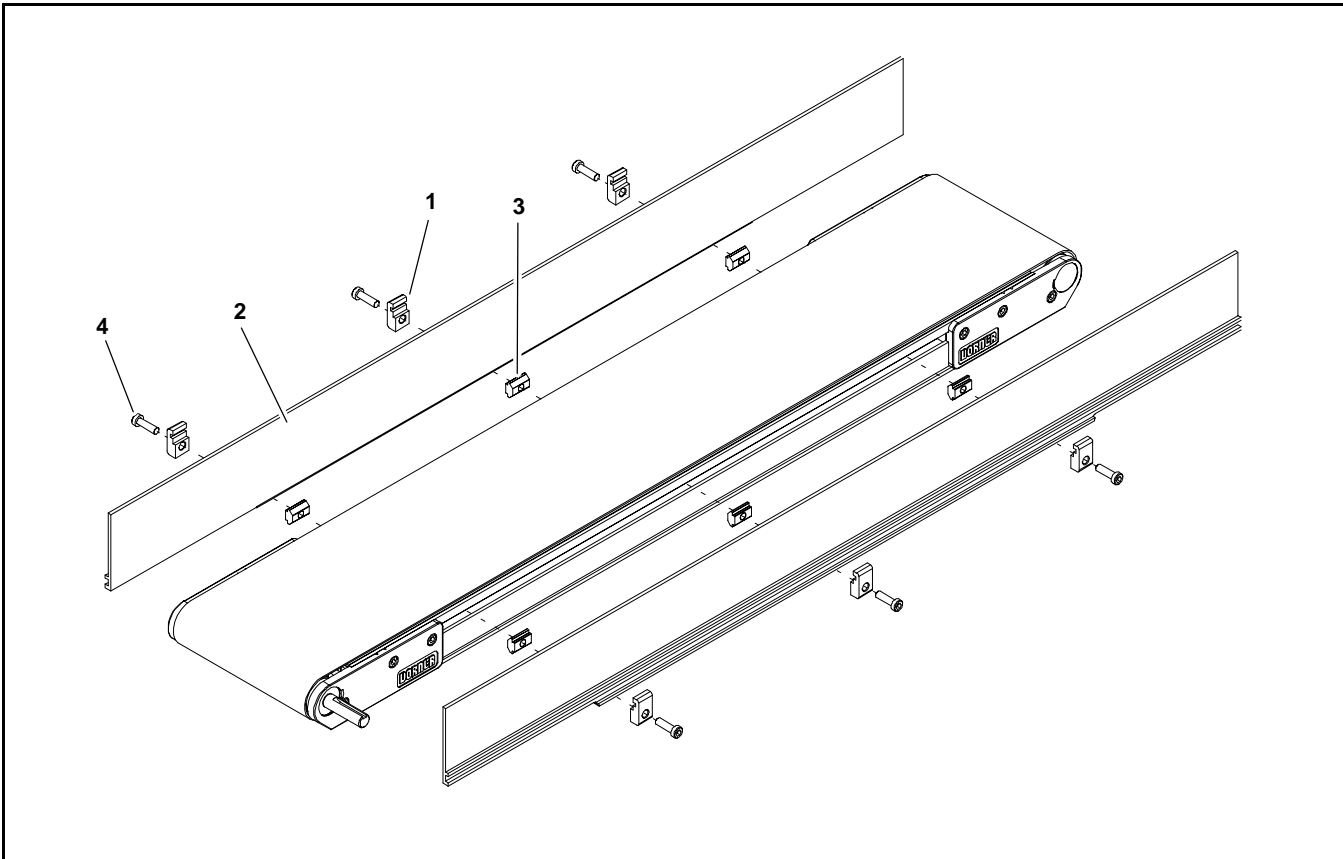

Item	Part Number	Description
1	200121	Guide Retaining Clip
2	280403- <u>LLLLL</u>	3" (76 mm) High Side Guides
3	639971MK10	Single Drop-in Tee Bar (2200 Series Only) (x10)
4	920694M	Socket Head Screw, M6 x 20 mm (2200 Series)
	807-1937	Self-Drilling Hex Head Screw, 1/4-20x1" (2300 Series)
<u>LLLLL</u> = part length in inches with 2 decimal places		
Example: Part Length = 35.25" <u>LLLLL</u> = 03525		

-05 1.5" (38 mm) Aluminum Side

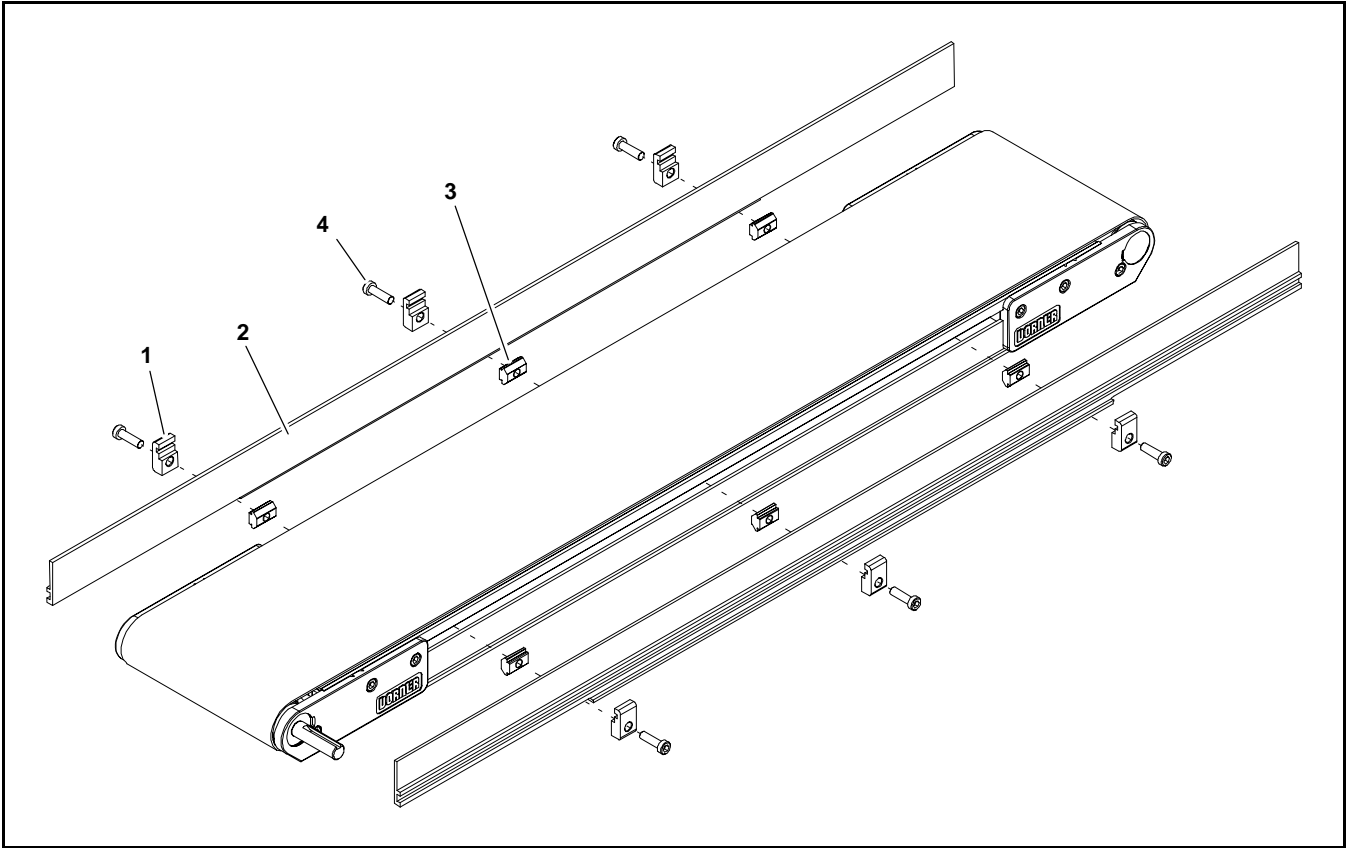

Item	Part Number	Description
1	200121	Guide Retaining Clip
2	280503- <u>LLLLL</u>	1.5" (38 mm) High Side Guides
3	639971MK10	Single Drop-in Tee Bar (2200 Series Only) (x10)
4	920694M	Socket Head Screw, M6 x 20 mm (2200 Series)
	807-1937	Self-Drilling Hex Head Screw, 1/4-20x1" (2300 Series)
<u>LLLLL</u> = part length in inches with 2 decimal places		
Example: Part Length = 35.25" <u>LLLLL</u> = 03525		

Service Parts

-07 Low to Side Wiper

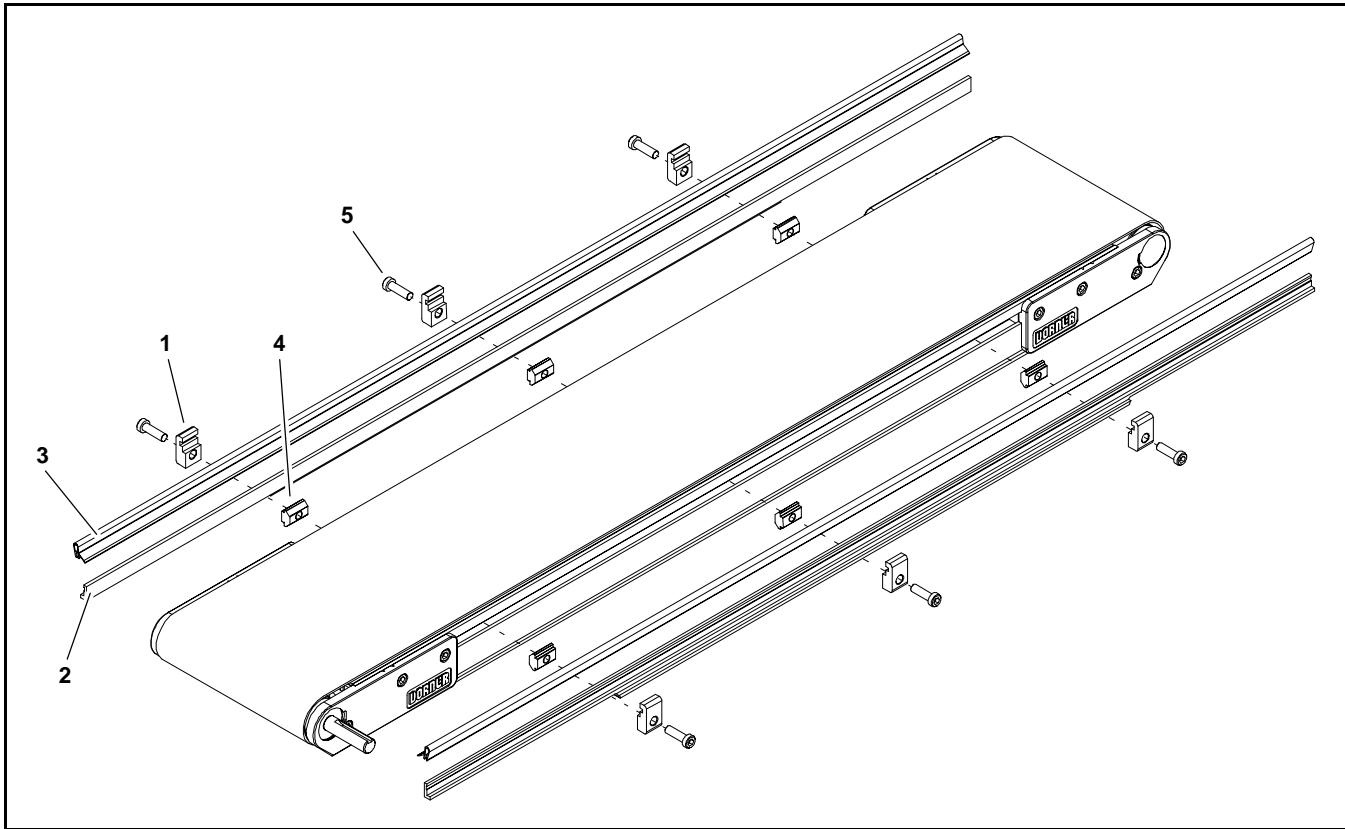

Item	Part Number	Description
1	200121	Guide Retaining Clip
2	280903-LLLLL	0.5" (13 mm) High Side Guides
3	41-00-24	Side Wiper Nylatron (per foot)
4	639971MK10	Single Drop-in Tee Bar (2200 Series Only) (x10)
5	920694M	Socket Head Screw, M6 x 20 mm (2200 Series)
	807-1937	Self-Drilling Hex Head Screw, 1/4-20x1" (2300 Series)
LLLLL = part length in inches with 2 decimal places		
Example: Part Length = 35.25" LLLLL = 03525		

-09 Low to High Side

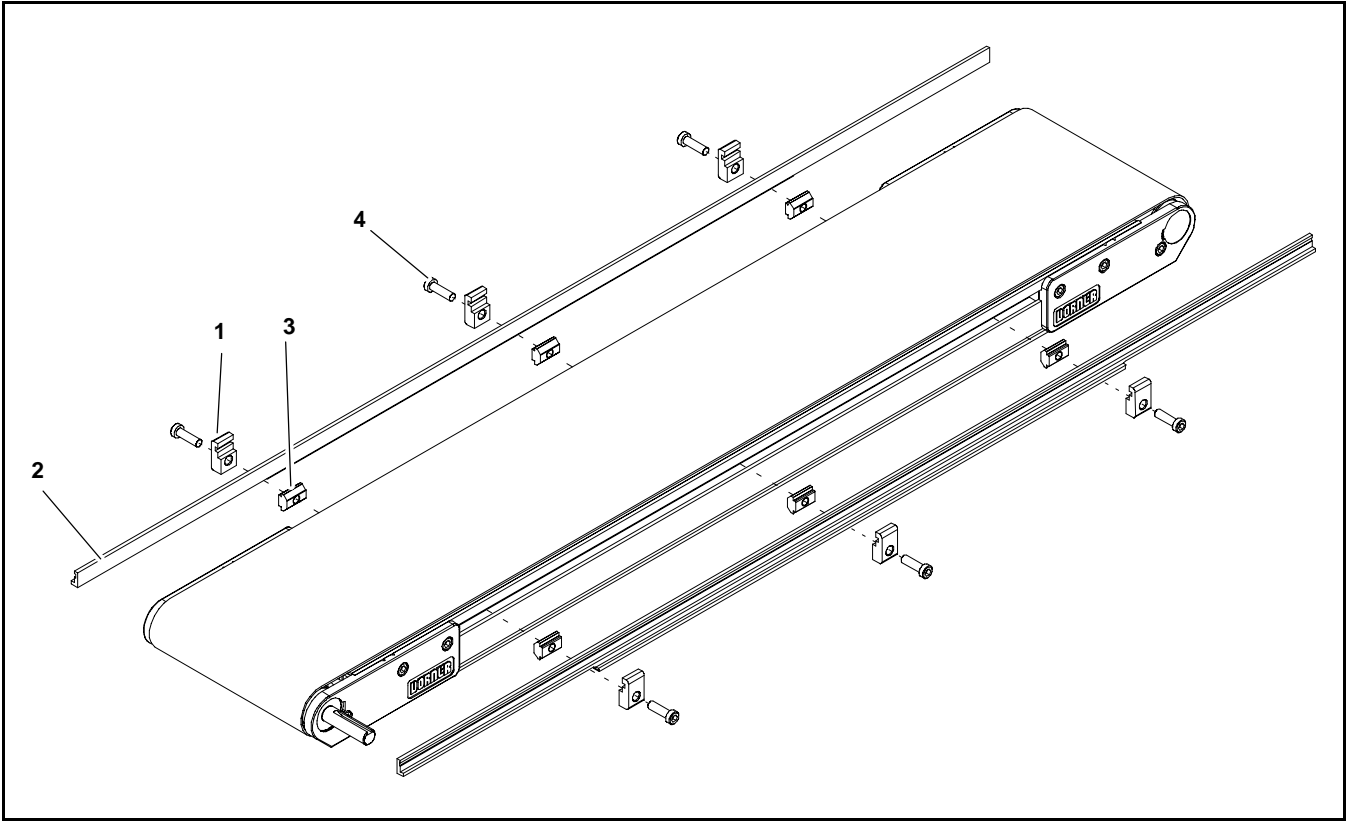

Item	Part Number	Description
1	200121	Guide Retaining Clip
2	280903-LLLLL	0.5" (13 mm) High Side Guides
3	639971MK10	Single Drop-in Tee Bar (2200 Series Only) (x10)
4	920694M	Socket Head Screw, M6 x 20 mm (2200 Series)
	807-1937	Self-Drilling Hex Head Screw, 1/4-20x1" (2300 Series)
LLLLL = part length in inches with 2 decimal places		
Example: Part Length = 35.25" LLLLL = 03525		

Service Parts

-10.5" (13 mm) Extruded Plastic

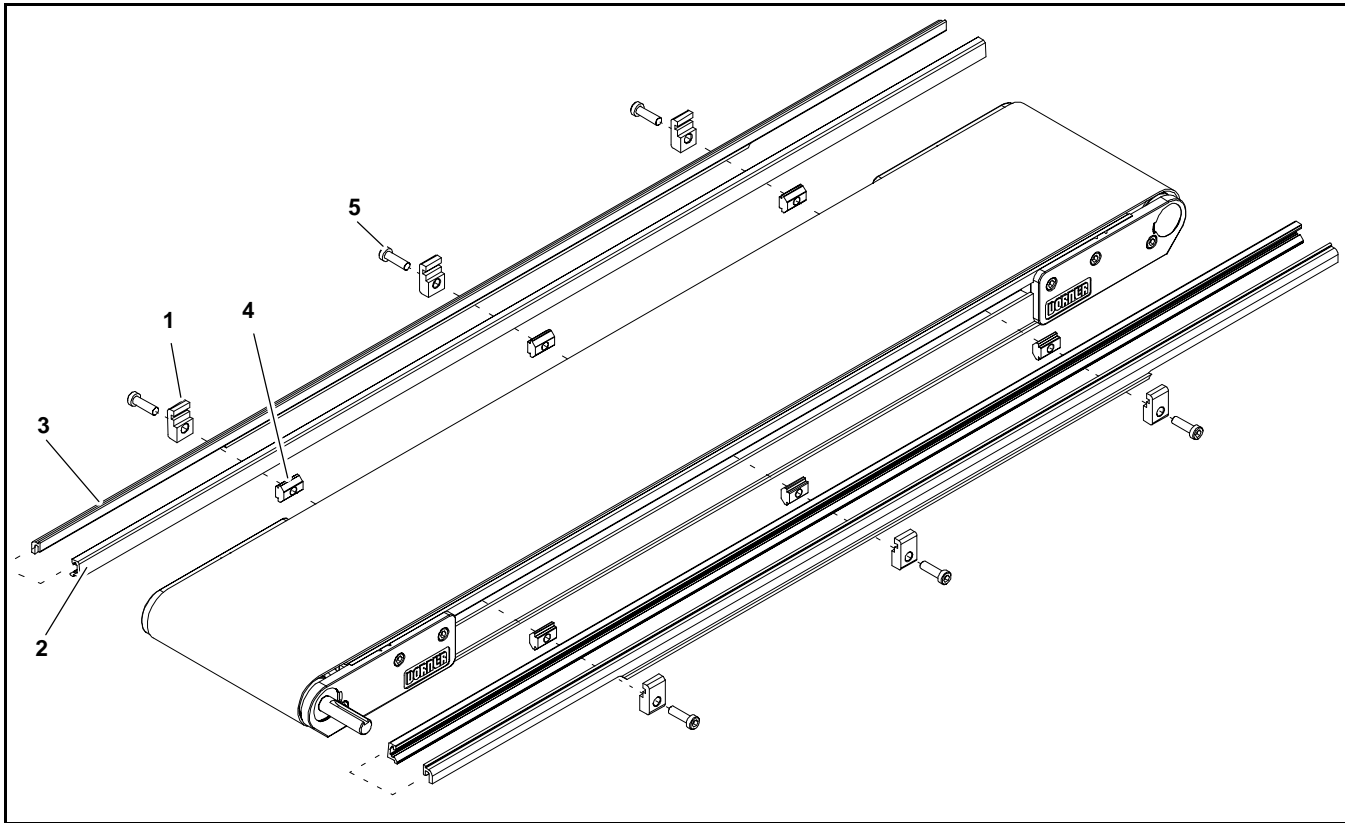

Item	Part Number	Description
1	200121	Guide Retaining Clip
2	200054P	Snap-On Guide (per foot)
3	281003-LLLLL	0.5" (13 mm), Plastic Guides
4	639971MK10	Single Drop-in Tee Bar (2200 Series Only) (x10)
5	920694M	Socket Head Screw, M6 x 20 mm (2200 Series)
	807-1937	Self-Drilling Hex Head Screw, 1/4-20x1" (2300 Series)
LLLLL = part length in inches with 2 decimal places		
Example: Part Length = 35.25" LLLLL = 03525		

-13 Adjustable Guiding

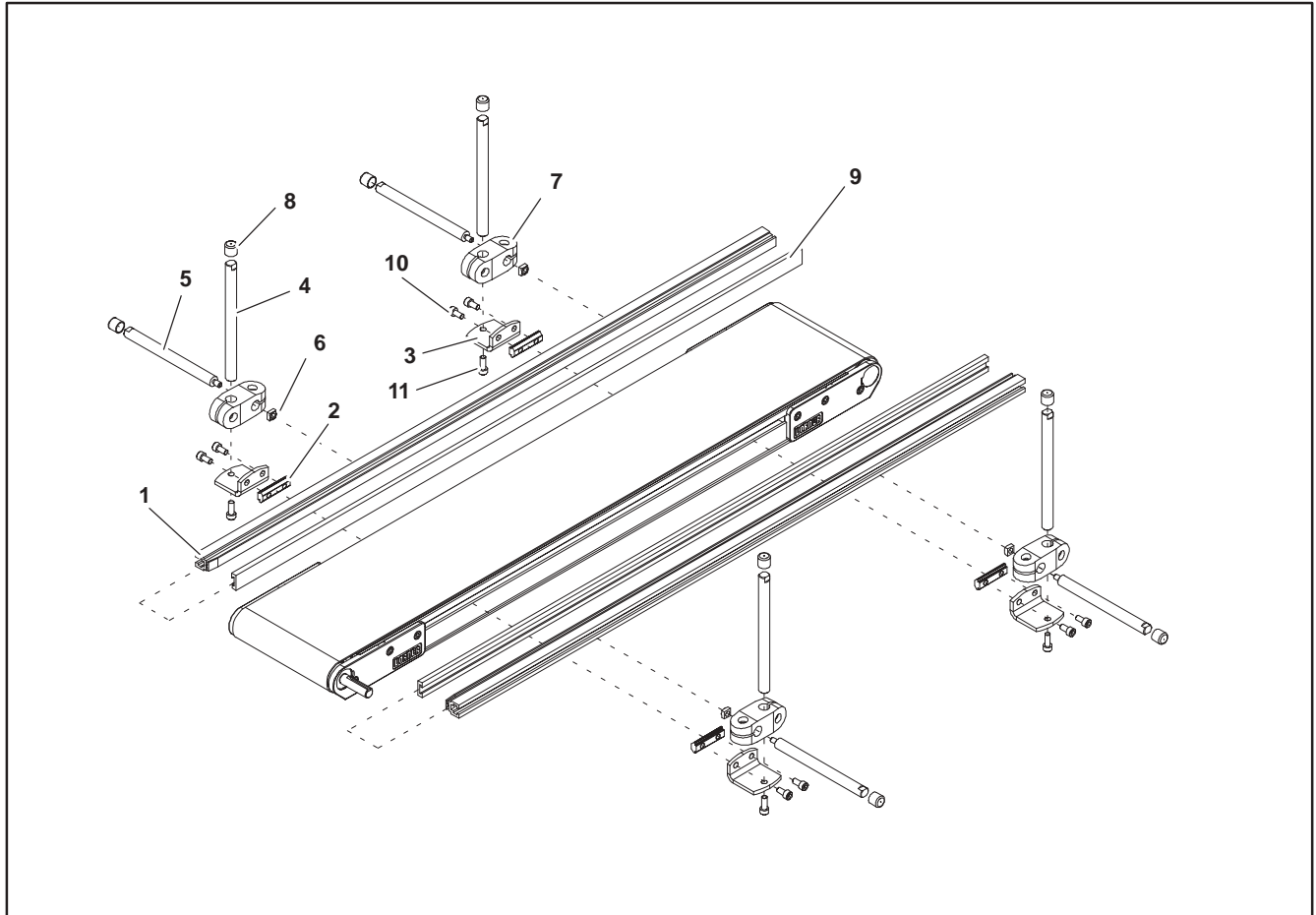

Item	Part Number	Description
1	460063- <u>LLLLL</u>	Aluminum Profile Guide
2	200830M	Drop-In Tee Bar (2200 Series Only)
3	202004	Mounting Bracket
4	202027M	Guide Mounting Shaft Vertical
5	202028M	Guide Mounting Shaft Horizontal
6	674175MP	Square Nut
7	807-652	Cross Block
8	807-948	Vinyl Shaft Cap
9	614068P	Flat Extruded Guide (per foot)
10	920612M	Socket Head Screw, M6 x 12 mm (2200 Series)
	807-1937	Self-Drilling Hex Head Screw, 1/4-20x1" (2300 Series)
11	920616M	Socket Head Screw, M6 x 16 mm
<u>LLLLL</u> = part length in inches with 2 decimal places		
Example: Part Length = 35.25" <u>LLLLL</u> = 03525		

Service Parts

-14 Tool-Less Adjustable Guiding

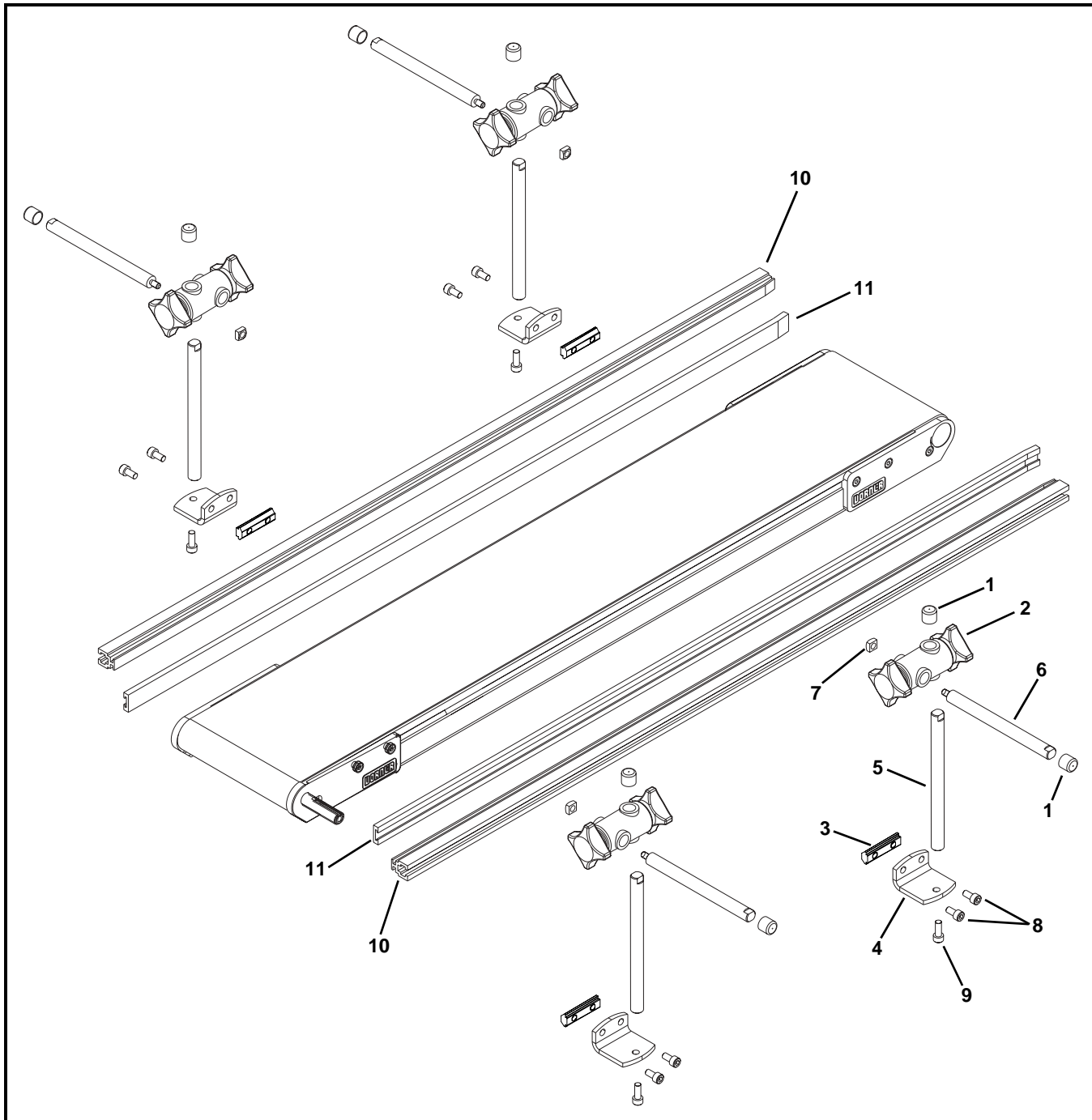

Item	Part Number	Description
1	807-948	Shaft Cap
2	807-1470	Cross Block
3	200830M	Drop-In Tee Bar (2200 Series Only)
4	202004M	Mounting Bracket
5	202027M	Vertical Mounting Guide Shaft
6	202028M	Horizontal Mounting Guide Shaft

Item	Part Number	Description
7	674175MP	Square Nut, M6-1.00
8	920612M	Socket Head Screw, M6-1.00 x 12 mm (2200 Series)
	807-1937	Self-Drilling Hex Head Screw, 1/4-20x1" (2300 Series)
9	920616M	Socket Head Screw, M6-1.00 x 16 mm
10	460063-LLLLL	Aluminum Profile Guide
11	614068P-LLLLL	Extruded Guide
LLLLL = Length in inches with 2 decimal places.		
Length Example: Length = 95.25" LLLLL = 09525		

2200 and 2300 Series iDrive Conveyors

0.5" (13 mm) Cleated Belt Guiding

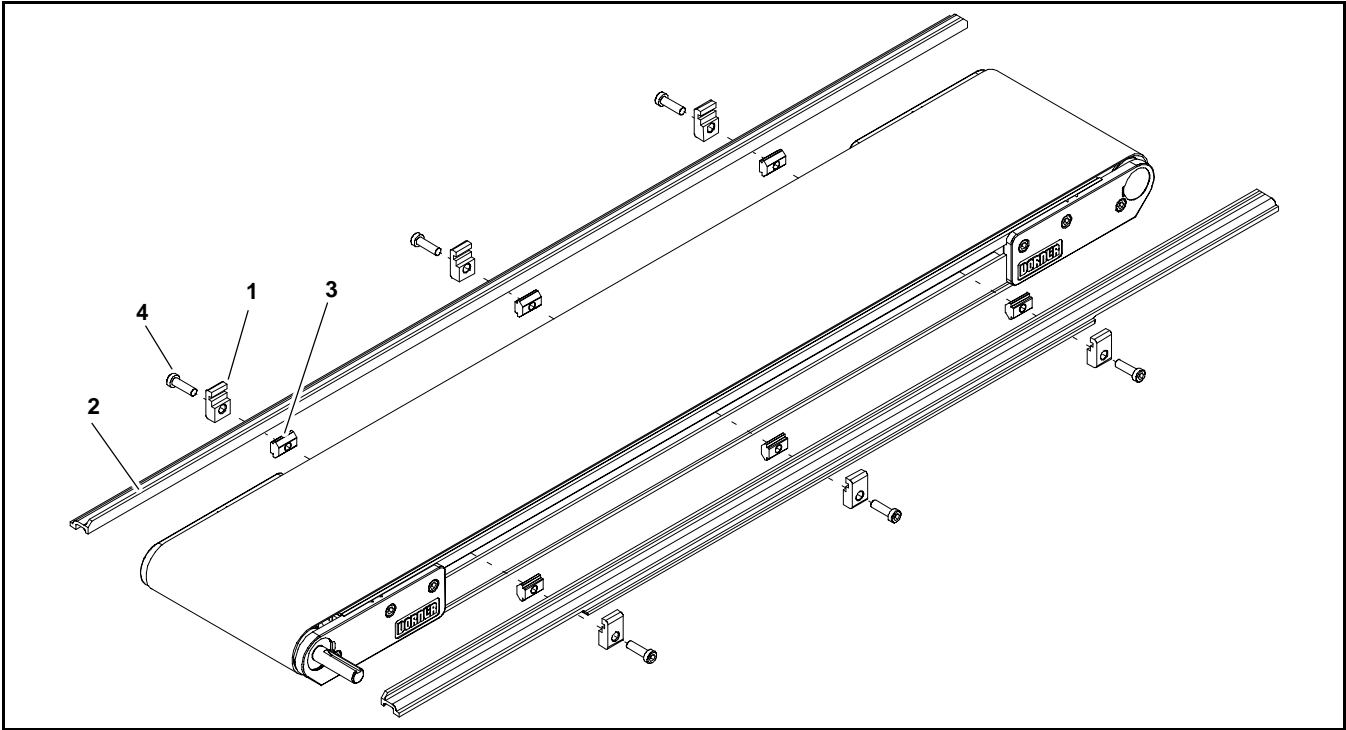

Item	Part Number	Description
1	200121	Guide Retaining Clip
2	281603-LLLLL	0.47" (13 mm) Cleated Guiding
3	639971MK10	Drop-In Tee Bar (2200 Series Only) (x10)
4	920694M	Socket Head Screw, M6 x 20 mm (2200 Series)
	807-1937	Self-Drilling Hex Head Screw, 1/4-20x1" (2300 Series)
LLLLL = part length in inches with 2 decimal places		
Example: Part Length = 35.25" LLLLL = 03525		

Service Parts

1" (25 mm) Cleated Belt Guiding

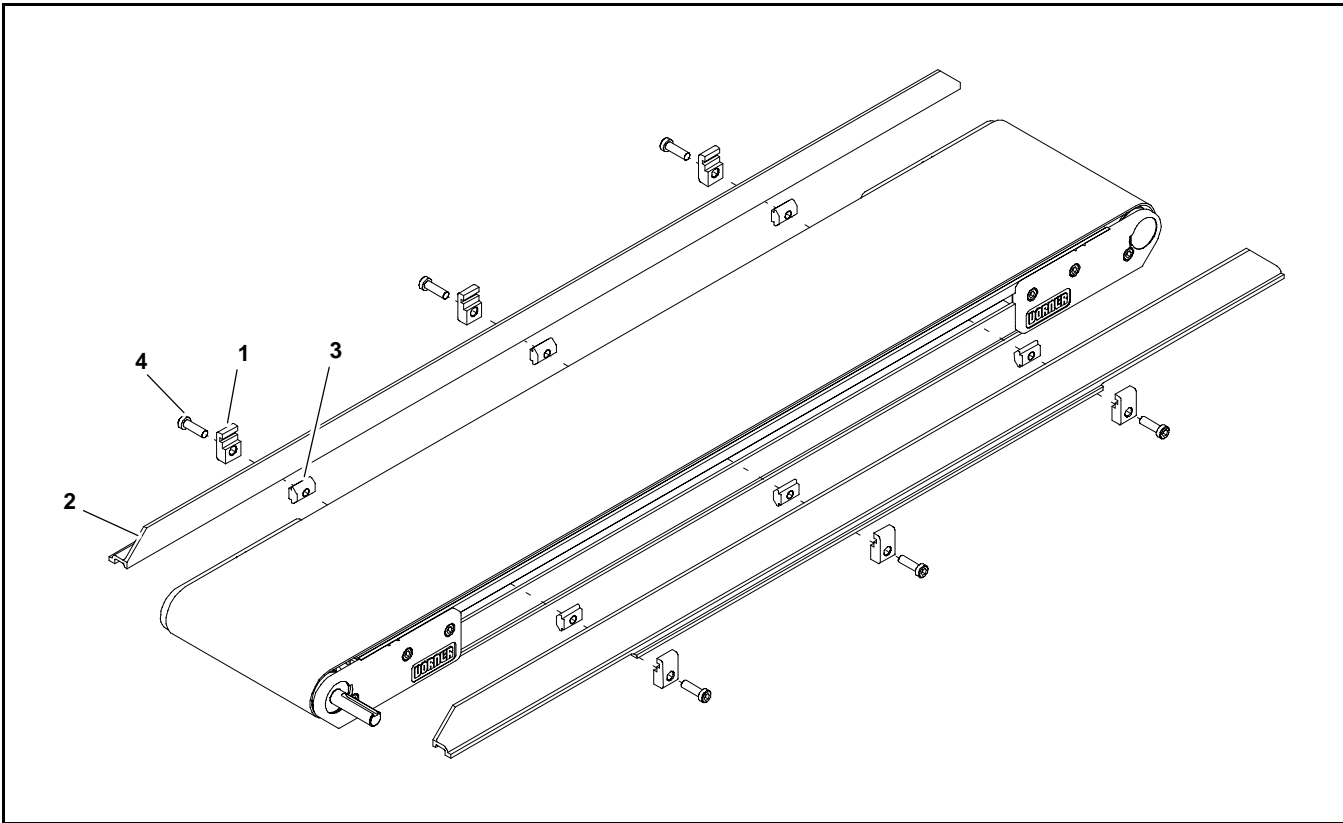

Item	Part Number	Description
1	200121	Guide Retaining Clip
2	281703-LLLLL	1" (25 mm) Cleated Guiding
3	639971MK10	Drop-In Tee Bar (2200 Series Only) (x10)
4	920694M	Socket Head Screw, M6 x 20 mm (2200 Series)
	807-1937	Self-Drilling Hex Head Screw, 1/4-20x1" (2300 Series)
LLLLL = part length in inches with 2 decimal places		
Example: Part Length = 35.25" LLLLL = 03525		

2" (51 mm) Cleated Belt Guiding

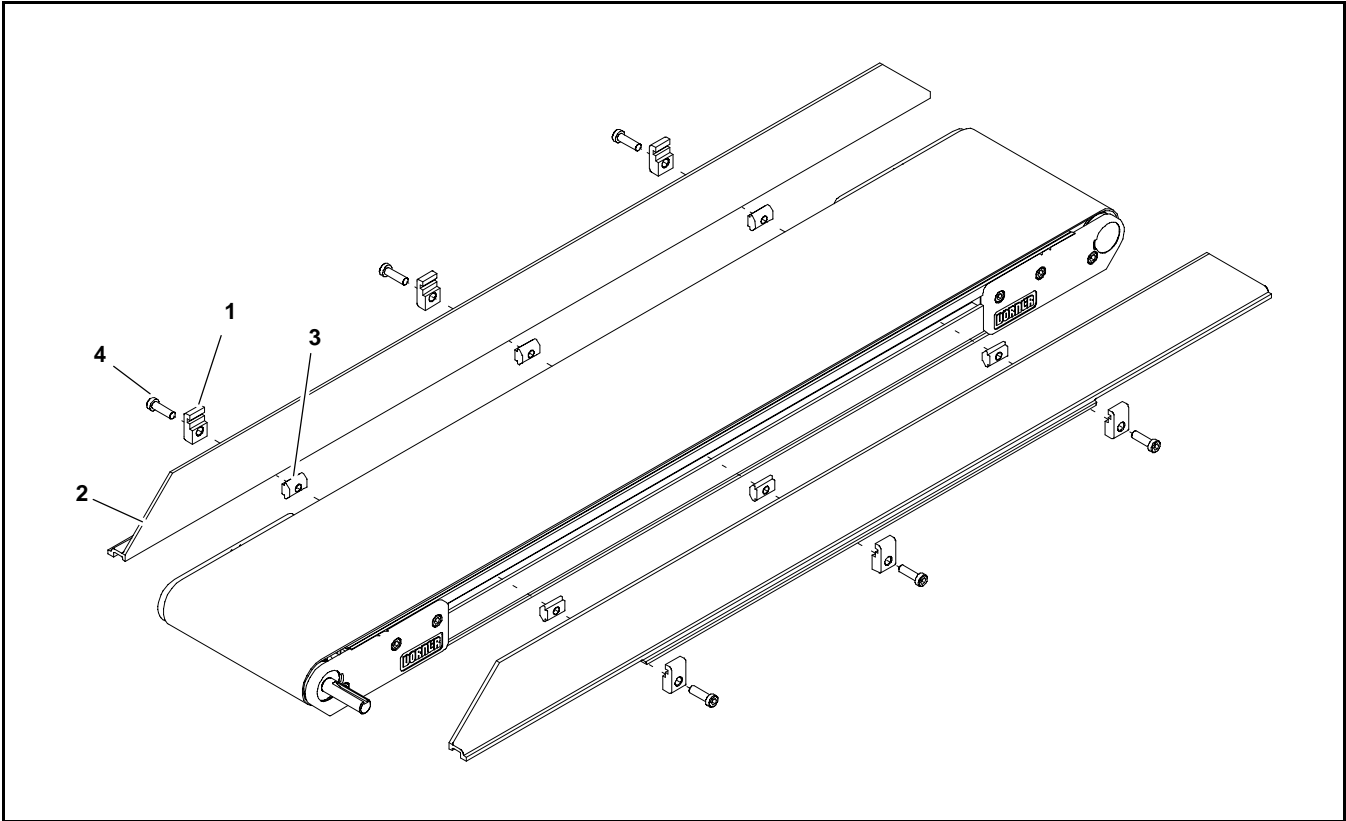

Item	Part Number	Description
1	200121	Guide Retaining Clip
2	281903-LLLLL	2.3" (58 mm) Cleated Guiding
3	639971MK10	Drop-In Tee Bar (2200 Series Only) (x10)
4	920694M	Socket Head Screw, M6 x 20 mm (2200 Series)
	807-1937	Self-Drilling Hex Head Screw, 1/4-20x1" (2300 Series)
LLLLL = part length in inches with 2 decimal places		
Example: Part Length = 35.25" LLLLL = 03525		

Service Parts

Flared Side Guiding

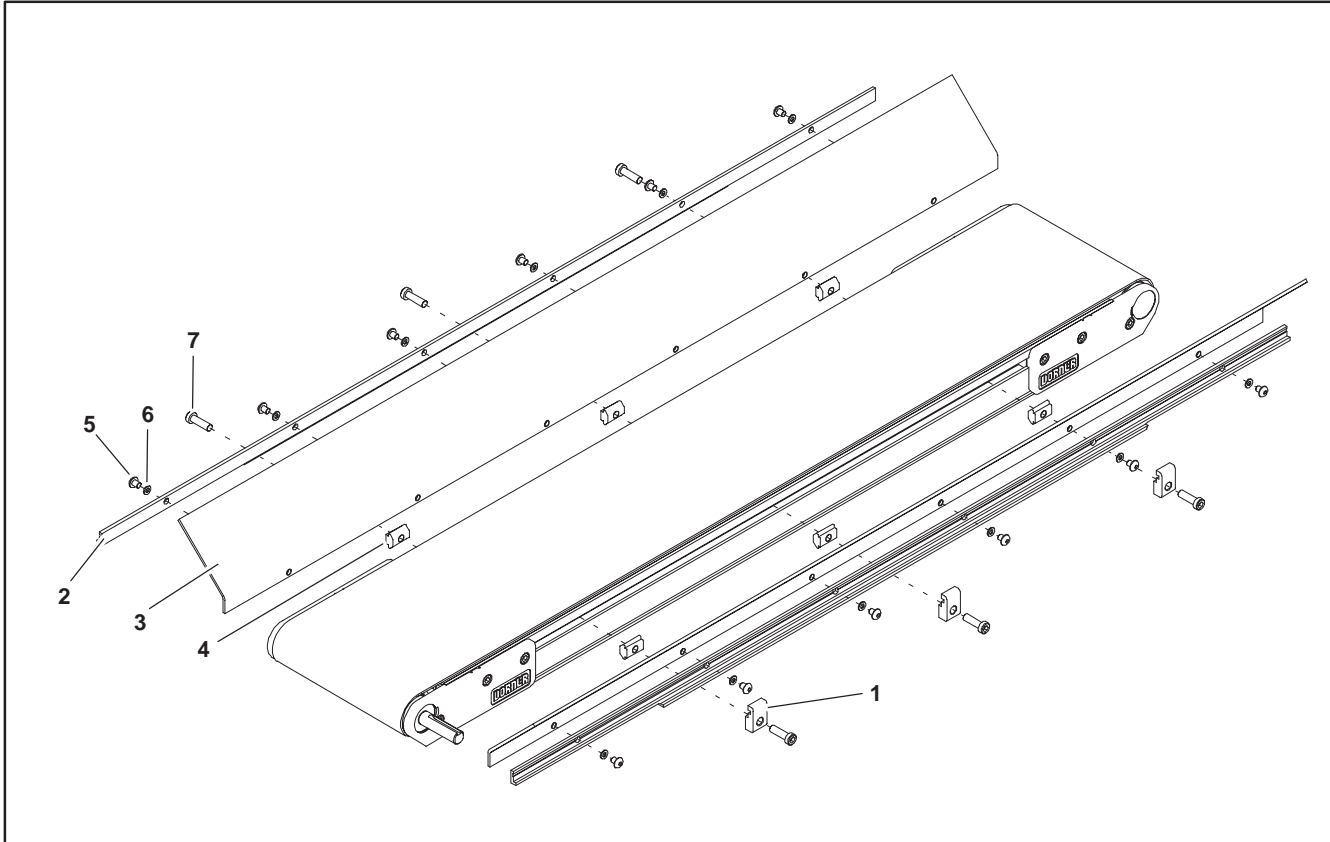

Item	Part Number	Description
1	200121	Guide Retaining Clip
2	202212	Side-Flare Mounting Guide 2' (610 mm)
	202213	Side-Flare Mounting Guide 3' (914 mm)
	202214	Side-Flare Mounting Guide 4' (1219 mm)
	202215	Side-Flare Mounting Guide 5' (1524 mm)
	202216	Side-Flare Mounting Guide 6' (1829 mm)

Item	Part Number	Description
3	202522M	Flared Guide 45° 2' (610 mm)
	202523M	Flared Guide 45° 3' (914 mm)
	202523M	Flared Guide 45° 4' (1219 mm)
	202523M	Flared Guide 45° 5' (1524 mm)
	202523M	Flared Guide 45° 6' (1829 mm)
4	639971MK10	Drop-In Tee Bar (2200 Series Only) (x10)
5	910506M	Button Head Screw, M5 x 6 mm
6	911-512	Washer
7	920694M	Cap Low-Head Screw, M6 x 20 mm (2200 Series)
	807-1937	Self-Drilling Hex Head Screw, 1/4-20x1" (2300 Series)

Flat Belt Stand Mount Assembly

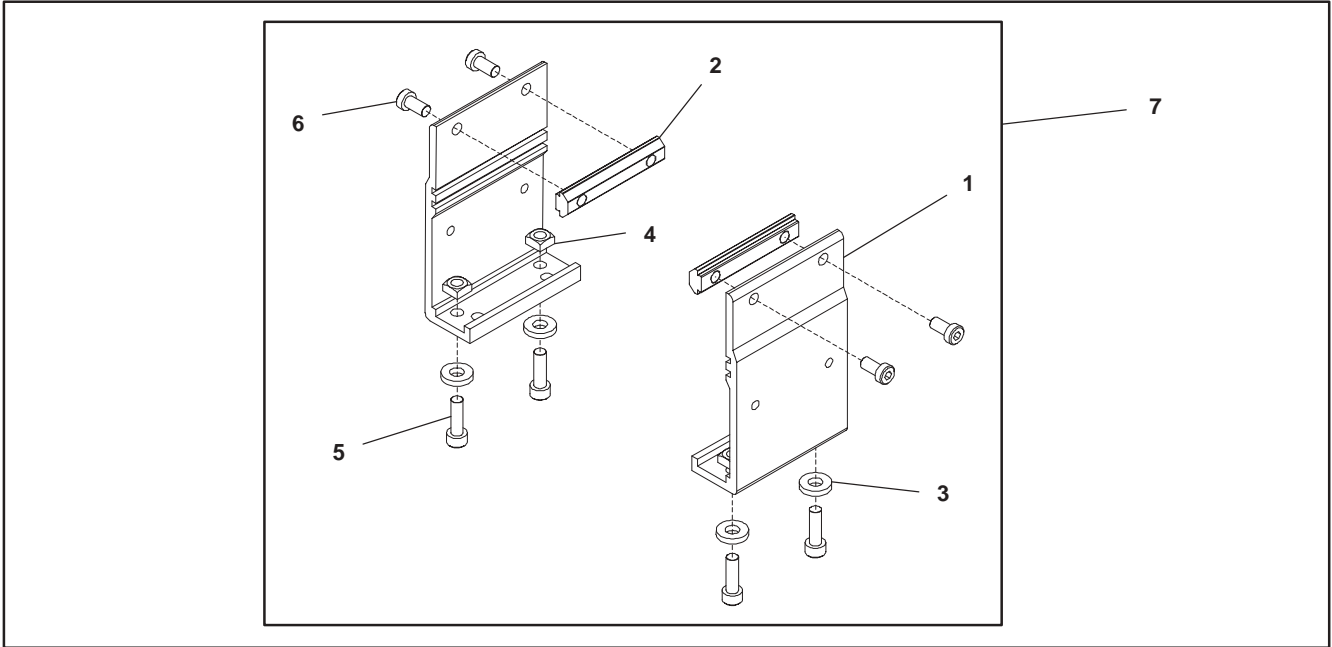

Item	Part Number	Description
1	240831	Stand Mount
2	300150MK4	Drop-In Tee Bar (2200 Series Only) (x4)
3	605279P	Washer
4	807-920	Square Nut, M6
5	920620M	Socket Head Screw, M6 x 20 mm
6	920692M	Socket Low Head Screw, M6 x 12 mm (2200 Series)
	807-1937	Self-Drilling Hex Head Screw, 1/4-20x1" (2300 Series)
7	240839	Flat Belt Stand Mount Assembly (2200 Series)
	715642	Flat Belt Stand Mount Assembly (2300 Series)

Service Parts

Cleated Belt Stand Mount Assembly

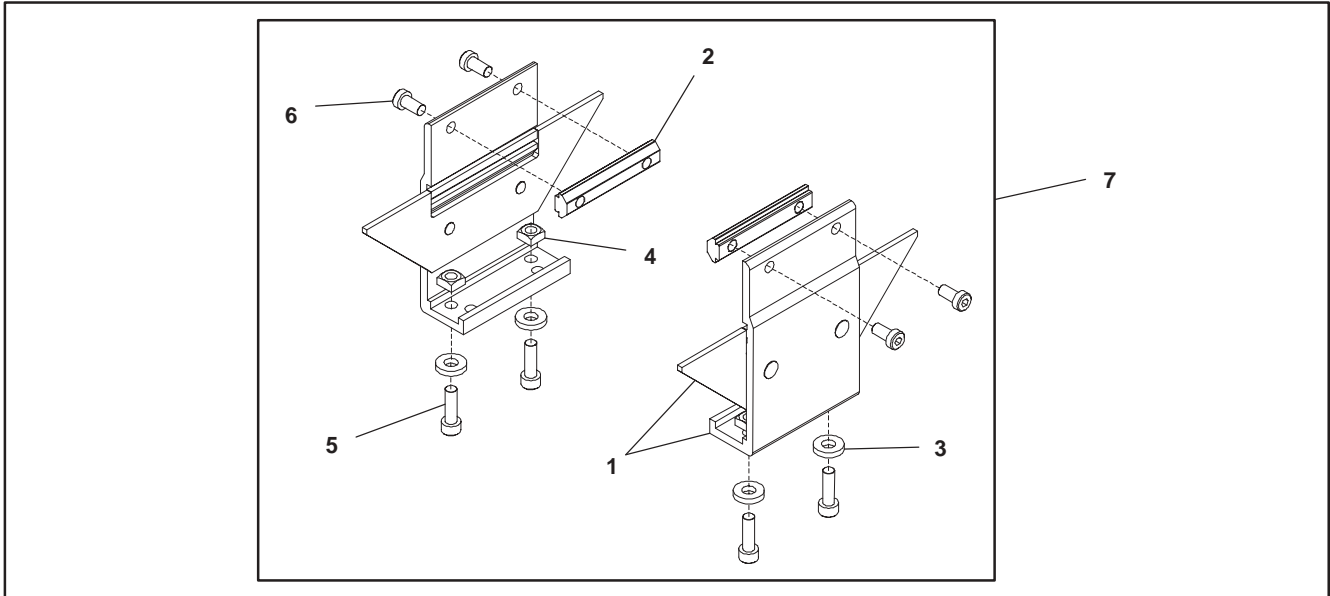

Item	Part Number	Description
1	240836	Cleated Mount Assembly
2	300150MK4	Drop-In Tee Bar (2200 Series Only) (x4)
3	605279P	Washer
4	807-920	Square Nut, M6
5	920620M	Socket Head Screw, M6 x 20 mm
6	920692M	Socket Low Head Screw, M6 x 12 mm (2200 Series)
	807-1937	Self-Drilling Hex Head Screw, 1/4-20x1" (2300 Series)
7	240838	Cleated Stand Mount Assembly (2200 Series)
	715645	Cleated Stand Mount Assembly (2300 Series)

Flat Belt Stand Mount Assembly for 2' (610 mm) Conveyors

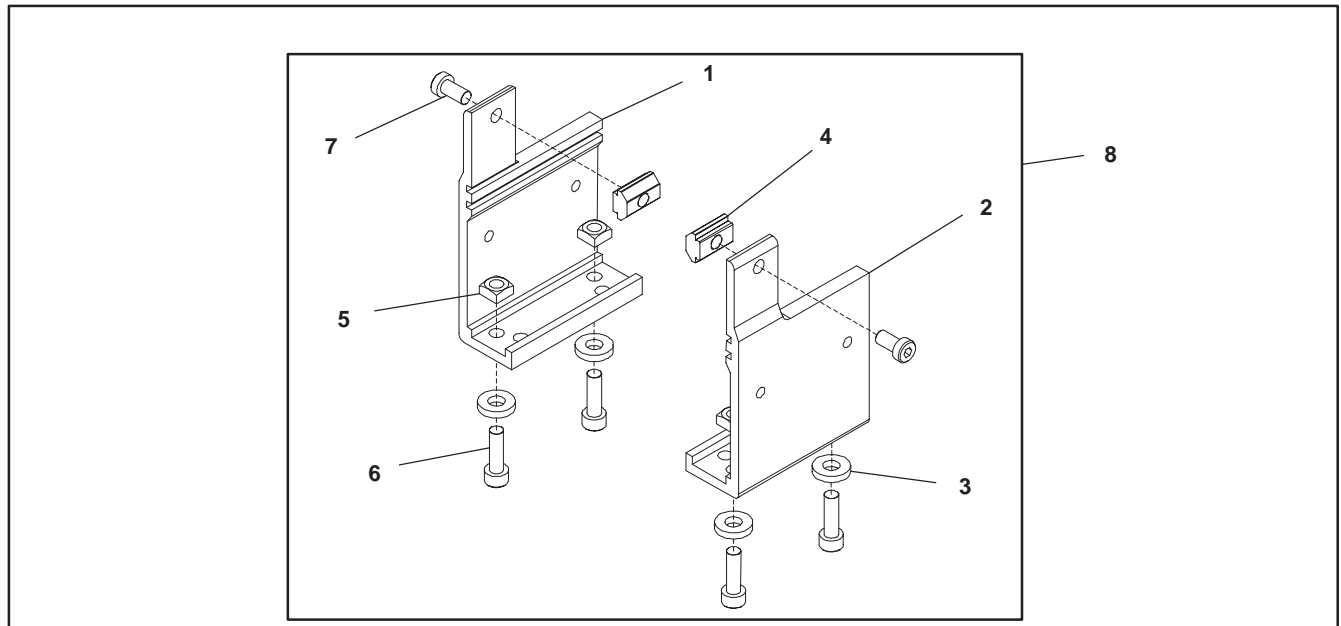

Item	Part Number	Description
1	240833	Stand Mount, LH 2' (610 mm)
2	240834	Stand Mount, RH 2' (610 mm)
3	605279P	Washer
4	639971MK10	Drop-In Tee Bar (2200 Series Only) (x10)
5	807-920	Square Nut, M6
6	920620M	Socket Head Screw, M6 x 20 mm
7	920692M	Socket Low Head Screw, M6 x 12 mm (2200 Series)
	807-1937	Self-Drilling Hex Head Screw, 1/4-20x1" (2300 Series)
8	240847	Flat Belt Stand Mount Assembly for 2' (610 mm) Conveyors (2200 Series)
	715644-DR	Flat Belt Stand Mount Assembly for 2' (610 mm) Conveyors (2300 Series)

Service Parts

Cleated Belt Stand Mount Assembly for 2' (610 mm) Conveyors

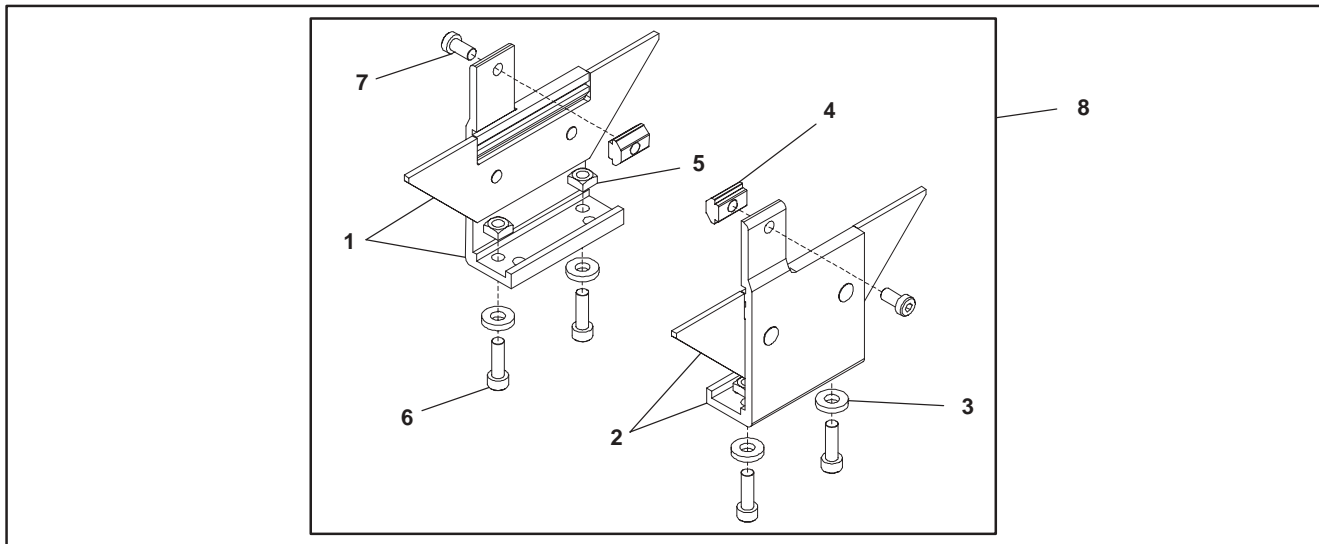

Item	Part Number	Description
1	240852	Cleated Stand Bracket Assembly LH 2' (610 mm) Conveyor
2	240853	Cleated Stand Bracket Assembly RH 2' (610 mm) Conveyor
3	605279P	Washer
4	639971MK10	Drop-In Tee Bar (2200 Series Only) (x10)
5	807-920	Square Nut M6
6	920620M	Socket Head Screw M6 x 20 mm
7	920692M	Socket Low Head Screw, M6 x 12 mm (2200 Series)
	807-1937	Self-Drilling Hex Head Screw, 1/4-20x1" (2300 Series)
8	240851	Cleated Belt Stand Mount Assembly for 2' (610 mm) Conveyors (2200 Series)
	715647-DR	Cleated Belt Stand Mount Assembly for 2' (610 mm) Conveyors (2300 Series)

3" (70 mm) to 6" (152 mm) Flat Belt Return Roller

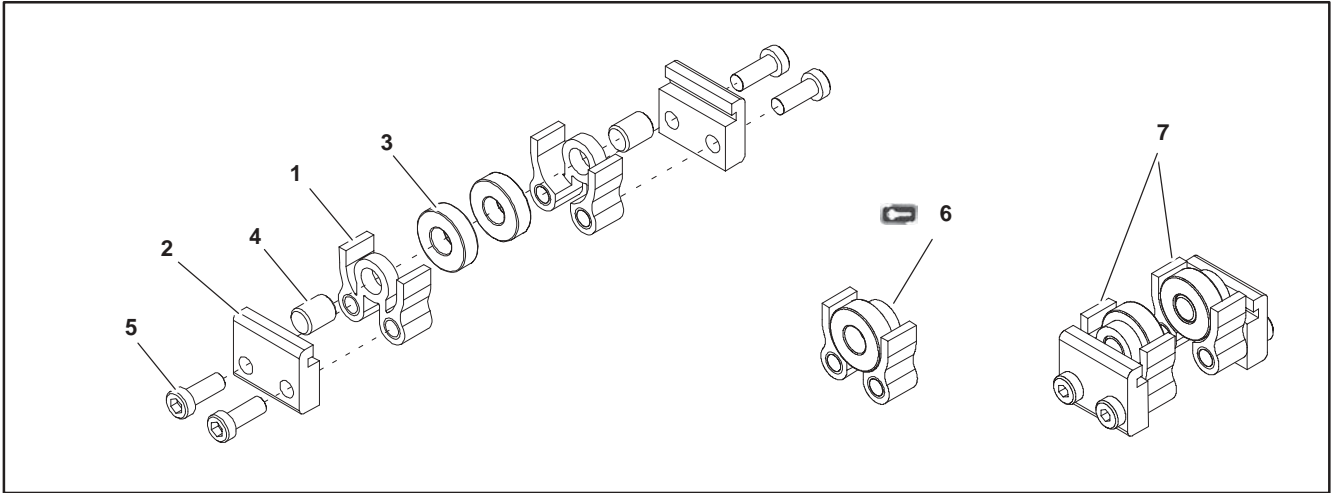

Item	Part Number	Description
1	240825	Return Roller Guard – Short
2	240827	Return Roller Clip
3	802-027	Bearing
4	913-100	Dowel Pin

Item	Part Number	Description
5	920693M	Socket Low Head Screw, M6 x 16 mm
6	240840	Roller Assembly (Includes Items 1, 3 and 4)
7	240830	2" (51 mm) to 6" (152 mm) Flat Belt Return Roller Assembly

8" (203 mm) to 18" (457 mm) Flat Belt Return Roller

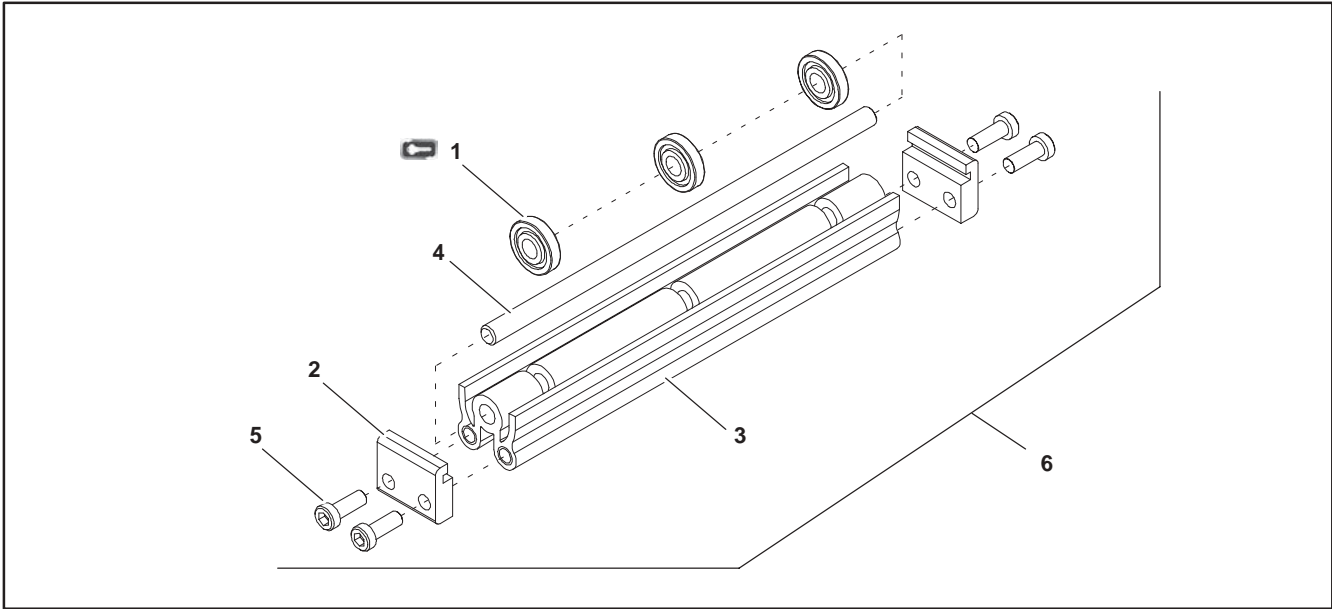

Item	Part Number	Description
1	240826	Return Roller
2	240827	Return Roller Clip
3	2409 WW	Return Roller Guard
4	2410 WW	Return Roller Rod
5	920693M	Socket Low Head Screw, M6 x 16 mm
6	2408 WW	8" (203mm) to 24" (610mm) Flat Belt Return Roller Assembly

~~WW~~= Conveyor width reference: 03, 04, 05, 06, 08, 10, 12 & 18

Service Parts

Cleated Belt Return Roller

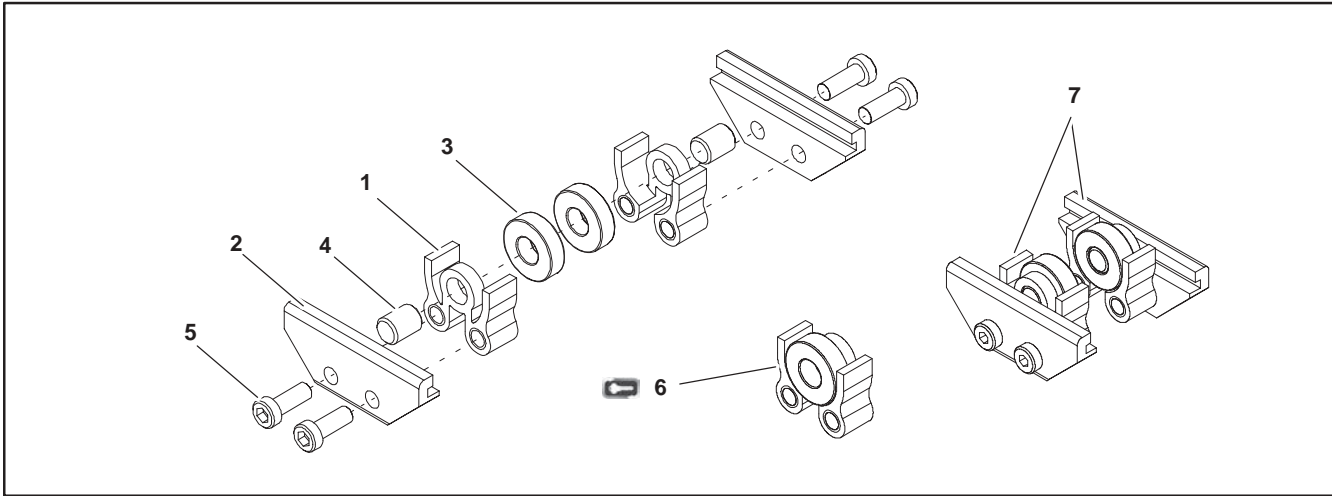

Item	Part Number	Description
1	240825	Return Roller Guard – Short
2	240828	Cleated Return Roller Clip
3	802-027	Bearing
4	913-100	Dowel Pin

Item	Part Number	Description
5	920693M	Socket Low Head Screw, M6 x 16 mm
6	240840	Roller Assembly (Includes Items 1, 3 and 4)
7	240832	Cleated Belt Return Roller Assembly

Photo Eye

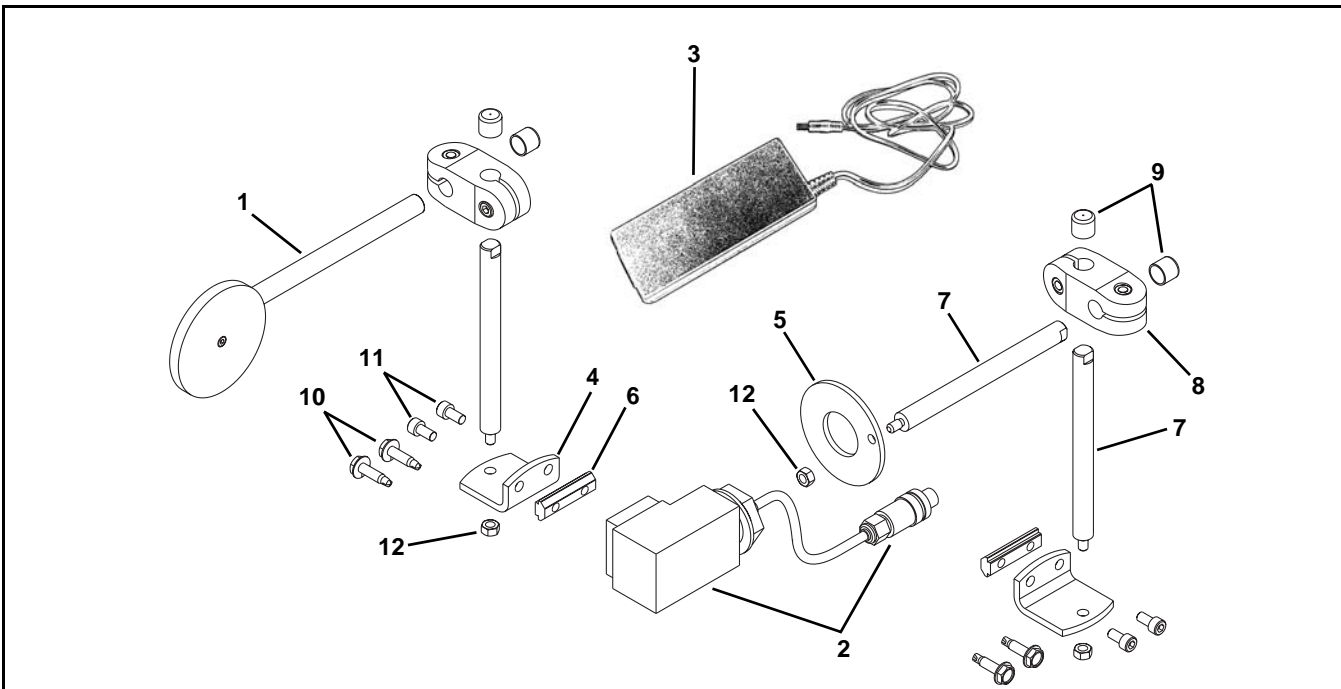

Item	Part Number	Description
1	201880	Reflector Mounting Assembly
2	201881	Eye Assembly with Plug
3	201882	Transformer with Plug
4	202004	Mounting Bracket
5	205109	Washer
6	200830M	Drop-In Tee Bar

Item	Part Number	Description
7	202028M	Mounting Shaft
8	807-652	Cross Block
9	807-948	Cap
10	807-1937	Drilling Screw, 1/4-20 x 1" (2300 Series)
11	920612M	Socket Head Screw, M6-1.00 x 12 mm (2200 Series)
12	990601M	Hex Nut

Conveyor Belt Part Number Configuration

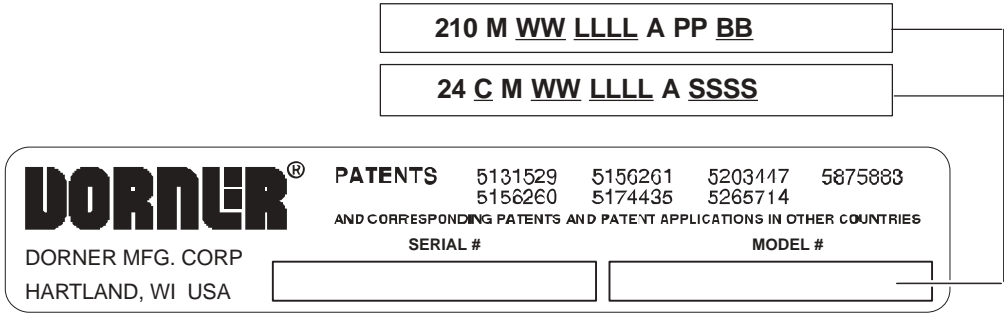

Figure 78

Flat Belt Part Number Configuration

Refer to Dorner patent plate (Figure 78). From the model number, determine conveyor width ("WW"), length ("LLLL") and belt type ("BB"). Use data to configure belt part number as indicated below. *Add "V" for V-guided belts.

22 - WW LLLL / BB V *

22 - _____ / ____ V*

(Fill In)

Cleated Belt Part Number Configuration

Refer to Dorner patent plate (Figure 78). From the model number, determine conveyor type ("T"), width ("WW"), length ("LLLL"), cleat type ("C") and cleat spacing ("SSSS"). Use data to configure belt part number as indicated below. *Add "V" for V-guided belts.

2T - WW LLLL C SSSS V *

2 - _____ / _____ V*

(Fill In)

Return Policy

Returns must have prior written factory authorization or they will not be accepted. Items that are returned to Dorner without authorization will not be credited nor returned to the original sender. When calling for authorization, please have the following information ready for the Dorner factory representative or your local distributor:

1. Name and address of customer.
2. Dorner part number(s) of item(s) being returned.
3. Reason for return.
4. Customer's original order number used when ordering the item(s).
5. Dorner or distributor invoice number (if available, part serial number).

A representative will discuss action to be taken on the returned items and provide a Returned Goods Authorization (RMA) number for reference. RMA will automatically close 30 days after being issued. To get credit, items must be new and undamaged. There will be a return charge on all items returned for credit, where Dorner was not at fault. It is the customer's responsibility to prevent damage during return shipping. Damaged or modified items will not be accepted. The customer is responsible for return freight.

Product Type									
Standard Products									Engineered to order parts
Product Line	Conveyors	Gearmotors & Mounting Packages	Support Stands	Accessories	Spare Parts (non-belt)	Spare Belts - Standard Flat Fabric	Spare Belts - Cleated & Specialty Fabric	Spare Belts - Plastic Chain	All equipment and parts
1100	30% return fee for all products except: 50% return fee for conveyors with modular belt, cleated belt or specialty belts						non-returnable		case-by-case
2200									
2200 Modular Belt									
2200 Precision Move									
2300									
2300 Modular Belt									
3200									
3200 LPZ									
3200 Precision Move									
4100									
5200									
5300									
6200									
Controls									
7200 / 7300	50% return fee for all products								
7350	non-returnable								
7360									
7400									
7600									

Returns will not be accepted after 60 days from original invoice date. The return charge covers inspection, cleaning, disassembly, disposal and reissuing of components to inventory. If a replacement is needed prior to evaluation of returned item, a purchase order must be issued. Credit (if any) is issued only after return and evaluation is complete.

Dorner has representatives throughout the world. Contact Dorner for the name of your local representative. Our Customer Service Team will gladly help with your questions on Dorner products.

For a copy of Dorner's Warranty, contact factory, distributor, service center or visit our website at www.dorner.com.

For replacement parts, contact an authorized Dorner Service Center or the factory.

 <p>Dorner Mfg. Corp. reserves the right to change or discontinue products without notice. All products and services are covered in accordance with our standard warranty. All rights reserved. © Dorner Mfg. Corp. 2013</p>	<p>DORNER MFG. CORP. 975 Cottonwood Ave., PO Box 20 Hartland, WI 53029-0020 USA TEL 1-800-397-8664 (USA) FAX 1-800-369-2440 (USA) Internet: www.dorner.com</p>	<p>Outside the USA: TEL 1-262-367-7600 FAX 1-262-367-5827</p>
---	--	---