



2200 Series Version 2 Conveyors

Installation, Maintenance & Parts Manual



For other service manuals visit our website at:
www.dornerconveyors.com/manuals-literature

Record Conveyor Serial Number Here

Table of Contents

Introduction	4	Guide Clips	26
Warnings – General Safety	5	Adjustable Guides	26
Product Description	6	Notes	28
Specifications	6	Preventive Maintenance and Adjustment	29
Models:	6	Required Tools	29
Flat Belt 2200 Series End Drive Conveyor	6	Standard Tools	29
Cleared Belt 2200 Series End Drive Conveyor	6	Checklist	29
Flat Belt 2200 Series iDrive Conveyor	7	Lubrication	29
Cleared Belt 2200 Series iDrive Conveyor	7	Maintaining Conveyor Belt	29
Flat Belt 2200 Series Mid / Center Drive Conveyor	7	Troubleshooting	29
Flat Belt 2200 Series LPZ End Drive Conveyor	7	Cleaning	29
Cleared Belt 2200 Series LPZ End Drive Conveyor	7	Conveyor Belt Replacement	29
Conveyor Supports	8	Conveyor Belt Replacement Sequence	29
End Drive and iDrive Conveyor Supports	8	Belt Removal for End Drive and iDrive Conveyors	30
Maximum Distances:	8	Without Stands or Gearmotor Mounting Package	30
Mid / Center Drive Conveyor Supports	8	With Stands and Gearmotor Mounting Package	30
Maximum Distances:	8	Belt Removal for Center Drive Conveyors	31
Flat Belt LPZ Conveyor Supports	8	Gearmotor Mounting Package Removal	32
Maximum Distances:	8	Drive Module Removal	33
Maximum Angle:	8	Belt Removal from Drive Module	34
Cleared Belt LPZ Conveyor Supports	8	Belt Removal for Mid Drive Conveyors	34
Maximum Distances:	8	Belt Removal for LPZ Conveyors	35
Maximum Angle:	8	Cleared Belt Conveyors	35
End/Mid Drive Conveyor Specifications	9	Flat Belt Conveyors	36
Center Drive Conveyor Specifications	10	Belt Installation for End Drive and iDrive Conveyors	37
Flat Belt LPZ Conveyor Specifications	11	Without Stands or Gearmotor Mounting Package	37
Cleared Belt LPZ Conveyor Specifications	12	With Stands and Gearmotor Mounting Package	37
iDrive Conveyor Specifications	13	Belt Installation for Center Drive Conveyors	38
iDrive Motor Specifications	13	Belt Installation for LPZ Conveyors	40
iDrive Load Capacity (lbs)	14	Cleared Belt Conveyors	40
iDrive Load Capacity (lbs) (continued)	15	Flat Belt Conveyors	41
iDrive Load Capacity (lbs) (continued)	16	Conveyor Belt Tensioning	42
iDrive Load Capacity (lbs) (continued)	17	Conveyors with 1.25" (32 mm) Diameter Pulleys	42
iDrive Load Capacity (lbs) (continued)	18	Center Drive Conveyors	43
Installation	19	Conveyors with Nose Bar Idlers	43
Required Tools	19	Conveyor Belt Tracking	44
Recommended Installation Sequence	19	V-Guided Belts	44
Conveyors Up to 12 ft (3658 mm)	19	Non V-Guided Belts	44
Conveyors Longer Than 12 ft (3658 mm)	19	Pulley Replacement	44
Knuckles	20	A – Drive Pulley Removal	44
Mounting Brackets	21	B – iDrive Pulley Removal	45
Return Rollers	22	C – Idler Pulley Removal	47
Cleared Belt and 2–6" (51–152 mm) Wide		D – 5/16" (8 mm) Tight Radius	
Flat Belt Conveyors	22	Nosebar Bearing Removal	48
8–24" (203–610 mm) Wide Flat Belt Conveyors	22	E – 5/8" (16 mm) Nosebar Pulley Removal	49
iDrive Wiring	23	F – Center Drive Module Pulley Removal	50
Cover Mounted Controls		Drive Module Drive Pulley Removal	50
with 115 volt Power Supply	23	Drive Module Idler Pulley Removal	50
Cover Mounted Controls		G – Mid Drive Module Pulley Removal	50
with Remote Start/Stop Cable	23	H – Knuckle Idler Pulley Removal	52
Cover Mounted Controls		Bearing Removal and Replacement	52
with Customer Provided Power Supply	24	Removal	52
Cover Mounted Controls		Replacement	53
with Photo Eye Option	25	iDrive Motor Replacement	53

Table of Contents

Knuckle Return Roller Replacement.....	54
Cleated Belt Conveyor.....	54
Flat Belt Conveyor.....	55
Tail Plate Shaft Knockout Removal.....	56
Pinion Replacement.....	57
Service Parts.....	60
End Drive Tail.....	60
iDrive Tail.....	62
Idler Tail.....	64
5/16" (8 mm) Tight Radius Nosebar Tail.....	66
5/8" (16 mm) Nosebar Tail.....	67
Center Drive Module.....	68
Mid Drive Module.....	70
Frame Assembly.....	72
Flat Belt Knuckle.....	74
Cleated Belt Lower Knuckle.....	75
Cleated Belt Upper Knuckle.....	76
#04 Profile - 3.00" (76 mm) Aluminum Side.....	77
#05 Profile - 1.50" (38 mm) Aluminum Side.....	78
#07 Profile - Low to Side Wiper.....	79
#09 Profile - Low to High Side.....	80
#10 Profile - .5" (13 mm) Extruded Plastic Side.....	81
#13, 33 & 43 Profile - Adjustable Guiding.....	82
#14, 34 & 44 Profile - Tool-Less Adjustable Guiding... ..	83
#16, 36 & 46 Profile - Outboard Adjustable Guiding... ..	84
#19, 39 & 49 Profile - Horizontal Adjustable Guiding.. ..	85
#20, 40 & 50 Profile - Tool-Less Horizontal Adjustable Guiding.....	86
#2 Cleated Profile - 1.00" (25 mm) High Side.....	87
#4 Cleated Profile - 1.00" (25 mm) High Side (Non-Reversing).....	88
#3 Cleated Profile - 2.50" (64 mm) High Side.....	89
#5 Cleated Profile - 2.50" (64 mm) High Side (Non-Reversing).....	90
#3 Cleated LPZ Profile - 2.50" (64 mm) High Side.....	91
#5 Cleated LPZ Profile - 2.50" (64 mm) High Side (Non-Reversing).....	92
Flat Belt Mounting Brackets.....	93
Cleated Belt Mounting Brackets.....	93
Flat Belt Mounting Brackets for Short Conveyors.....	94
Cleated Belt Mounting Brackets for Short Conveyors... ..	94
Flat Belt Mounting Brackets Assembled to the Tail.....	95
Connecting Assembly without Stand Mount.....	95
Flat Belt Connecting Assembly with Stand Mount.....	96
Cleated Belt Connecting Assembly with Stand Mount.....	96
2" (51 mm) to 6" (152 mm) Flat Belt Return Roller.....	97
8" (203 mm) to 24" (610 mm) Flat Belt Return Roller.. ..	97
Cleated Belt Return Roller.....	98
Photo Eye.....	98
Conveyor Belt Part Number Configuration.....	99
Return Policy.....	100

Introduction

IMPORTANT

<i>Some illustrations may show guards removed. DO NOT operate equipment without guards.</i>

Upon receipt of shipment:

- Compare shipment with packing slip. Contact factory regarding discrepancies.
- Inspect packages for shipping damage. Contact carrier regarding damage.
- Accessories may be shipped loose. See accessory instructions for installation.

Dorner's Limited Warranty applies.

Dorner has convenient, pre-configured kits of Key Service Parts for all conveyor products. These time saving kits are easy to order, designed for fast installation, and guarantee you will have what you need when you need it. Key Parts and Kits are marked in the Service Parts section of this manual with the Performance Parts Kits logo .

Dorner 2200 series conveyors are covered by Patent Numbers 5,174,435, 6,298,981, 6,422,382 and corresponding patents and patent applications in other countries.

Dorner reserves the right to make changes at any time without notice or obligation.

Warnings – General Safety

⚠ WARNING

The safety alert symbol, black triangle with white exclamation, is used to alert you to potential personal injury hazards.

⚠ DANGER



SEVERE HAZARD!
KEEP OFF CONVEYORS. Climbing, sitting, walking or riding on conveyor will result in death or serious injury.

⚠ WARNING



SEVERE HAZARD!
LOCK OUT POWER before removing guards or performing maintenance. Exposed moving parts can cause serious injury.

⚠ WARNING



BURN HAZARD!
DO NOT TOUCH the motor while operating, or shortly after being turned off. Motors may be HOT and can cause serious burn injuries.

⚠ WARNING



PUNCTURE HAZARD!
Handle drive shaft keyway with care. It may be sharp and could puncture the skin, causing serious injury.

⚠ DANGER



EXPLOSION HAZARD!

- DO NOT OPERATE CONVEYORS IN AN EXPLOSIVE ENVIRONMENT. The electric gearmotor generates heat and could ignite combustible vapors.
- Failure to comply will result in death or serious injury.

⚠ WARNING



CRUSH HAZARD!

- DO NOT place hands or fingers inside the conveyor while it is running.
- DO NOT wear loose garments while operating the conveyor. Loose garments can become caught up in the conveyor.
- Failure to comply could result in serious injury.

⚠ WARNING



CRUSH HAZARD!

- SUPPORT CONVEYOR SECTIONS PRIOR TO LOOSENING STAND HEIGHT OR ANGLE ADJUSTMENT SCREWS.
- Loosening stand height or angle adjustment screws may cause conveyor sections to drop down, causing serious injury.

⚠ WARNING



SEVERE HAZARD!

- Dorner cannot control the physical installation and application of conveyors. Taking protective measures is the responsibility of the user.
- When conveyors are used in conjunction with other equipment or as part of a multiple conveyor system, CHECK FOR POTENTIAL PINCH POINTS and other mechanical hazards before system start-up.
- Failure to comply could result in serious injury.

Product Description

Typical Conveyor Components 1:

- | | |
|----|----------------------------|
| 1 | Conveyor |
| 2 | Gearmotor Mounting Package |
| 3 | Gearmotor |
| 4 | Guiding & Accessories |
| 5 | Mounting Brackets |
| 6 | Return Rollers |
| 7 | Support Stand |
| 8 | Variable Speed Controller |
| 9 | Drive End |
| 10 | Idler/Tension End |

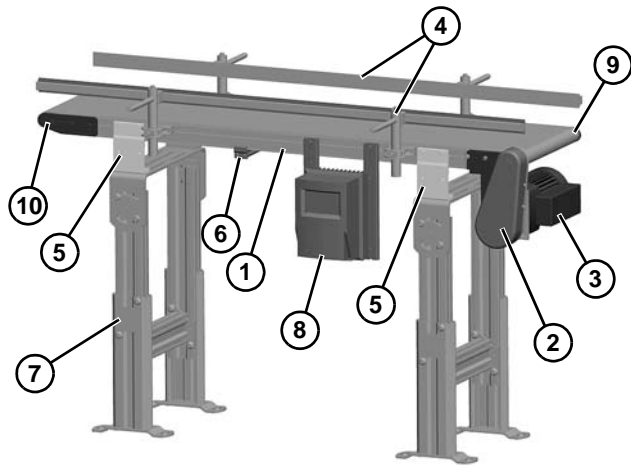

Figure 1

Typical iDrive Control Components 2:

- | | |
|---|---------------------------|
| 1 | Speed Control |
| 2 | Directional On/Off Switch |
| 3 | Power Input Jack |

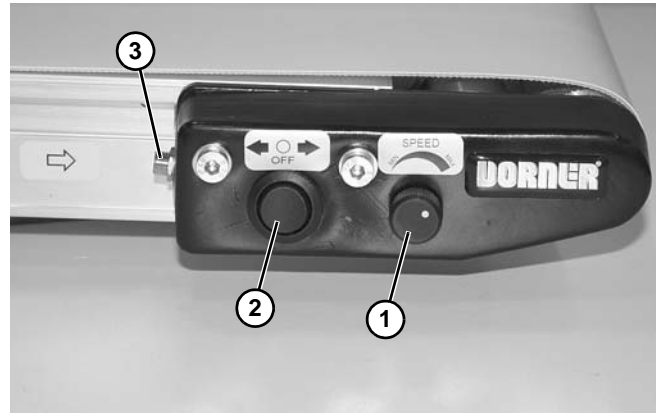
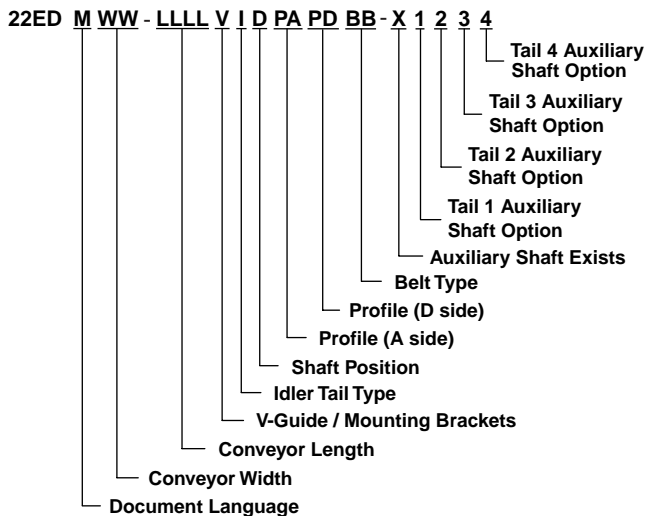

Figure 2

Specifications

Models:

Flat Belt 2200 Series End Drive Conveyor



Cleated Belt 2200 Series End Drive Conveyor

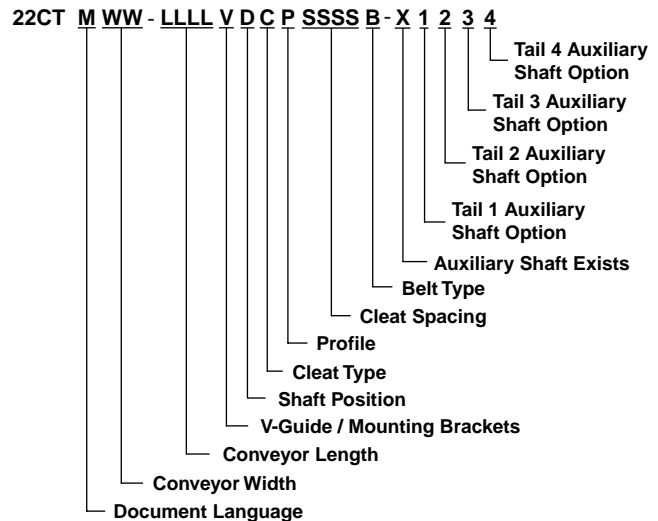

Flat Belt 2200 Series iDrive Conveyor

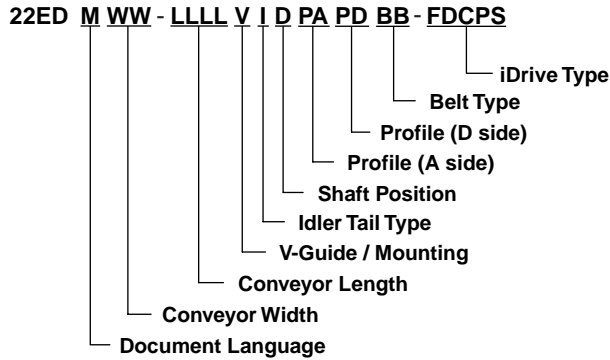

Flat Belt 2200 Series LPZ End Drive Conveyor

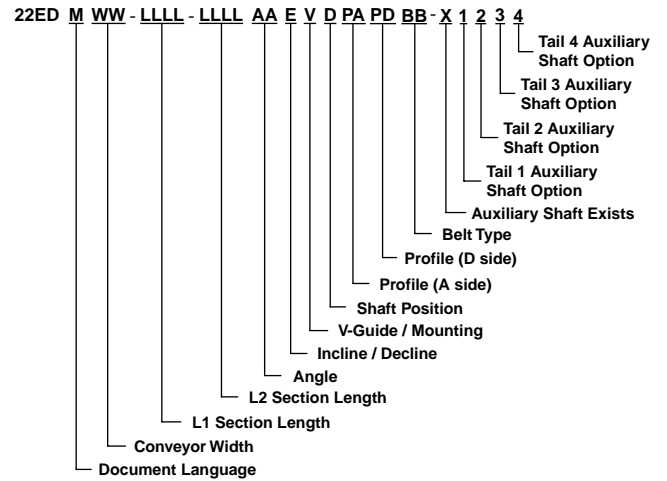

Cleated Belt 2200 Series iDrive Conveyor

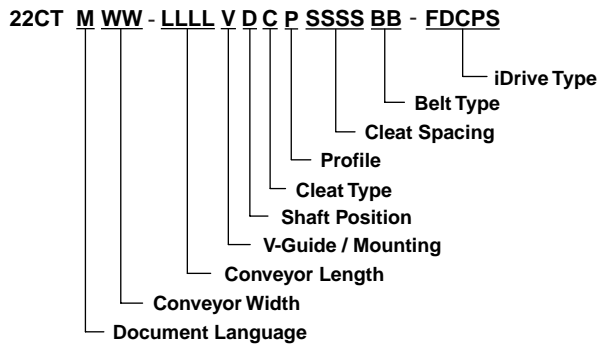

Cleated Belt 2200 Series LPZ End Drive Conveyor

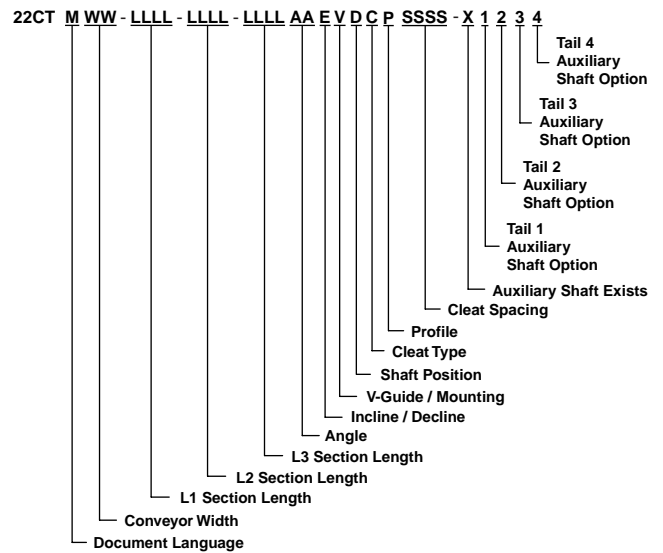

Flat Belt 2200 Series Mid / Center Drive Conveyor

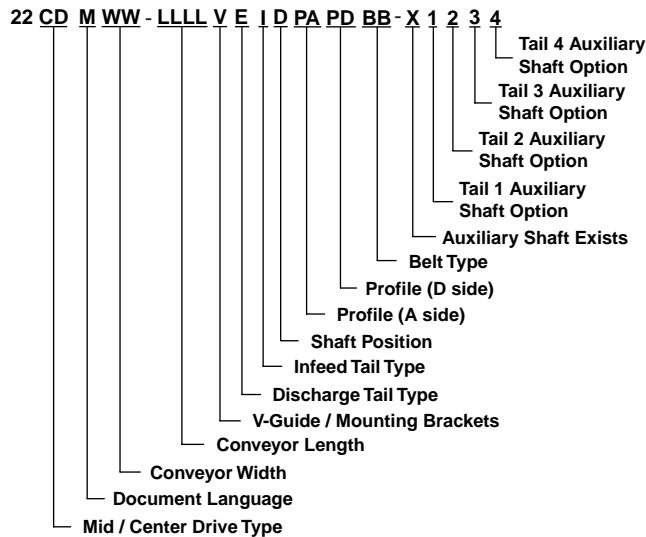

* See Ordering and Specifications Catalog for details.

Specifications

Conveyor Supports

End Drive and iDrive Conveyor Supports

Maximum Distances:

- 1 = 24" (610 mm)
- 2 = 18" (457 mm)
- 3 = 96" (2438 mm)

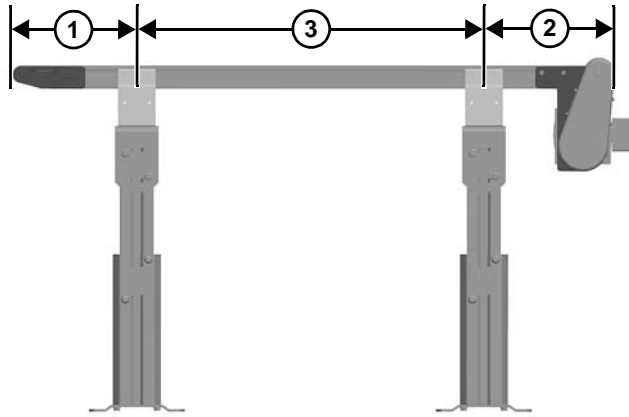

Figure 3

Flat Belt LPZ Conveyor Supports

Maximum Distances:

- 1 = 18" (457 mm) (Drive End)
- 2 = 96" (2438 mm)
- 3 = 24" (610 mm) (Idler End)

Maximum Angle:

- 4 = 5 to 20 degrees

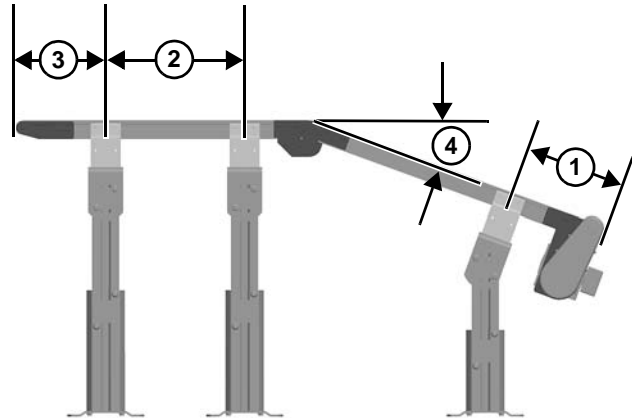

Figure 5

Mid / Center Drive Conveyor Supports

Maximum Distances:

- 1 = 24" (610 mm) (Idler End)
- 2 = 96" (2438 mm)**

** For conveyors longer than 13 ft (3962 mm), install support at joint.

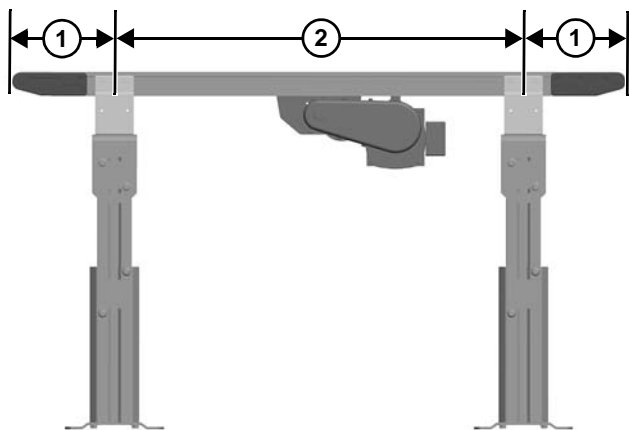

Figure 4

Cleated Belt LPZ Conveyor Supports

Maximum Distances:

- 1 = 18" (457 mm) (Drive End)
- 2 = 96" (2438 mm)
- 3 = 24" (610 mm) (Idler End)

Maximum Angle:

- 4 = 30 to 60 degrees

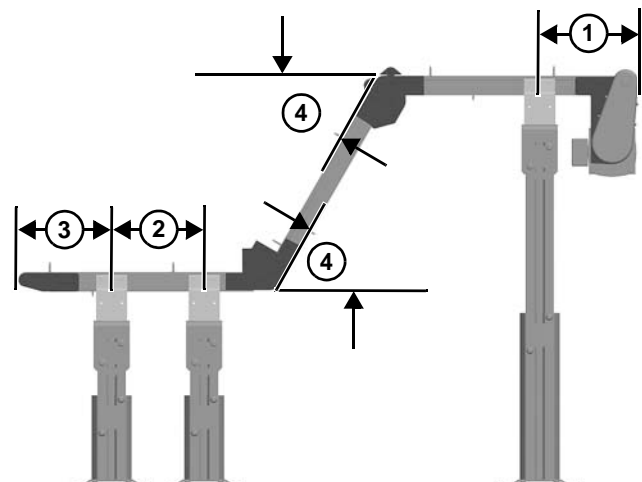

Figure 6

Specifications

End/Mid Drive Conveyor Specifications

Conveyor Width Reference (WW)	02	03	04	05	06	08	10
Conveyor Belt Width	1.75" (44 mm)	2.75" (70 mm)	3.75" (95 mm)	5" (127 mm)	6" (152 mm)	8" (203 mm)	10" (254 mm)
Maximum Conveyor Load* (See NOTE Below)	30 lb (14 kg)	35 lb (16 kg)	42 lb (19 kg)	50 lb (23 kg)	60 lb (27 kg)	70 lb (32 kg)	80 lb (36 kg)
End Drive Conveyor Startup Torque**	2 in-lb (0.2 Nm)	3 in-lb (0.3 Nm)	4 in-lb (0.5 Nm)	6 in-lb (0.7 Nm)	8 in-lb (0.9 Nm)	10 in-lb (1.1 Nm)	12 in-lb (1.4 Nm)
Mid Drive Conveyor Startup Torque**	4 in-lb (0.5 Nm)	5 in-lb (0.6 Nm)	6 in-lb (0.7 Nm)	8 in-lb (0.9 Nm)	10 in-lb (1.1 Nm)	12 in-lb (1.4 Nm)	14 in-lb (1.6 Nm)
End Drive Conveyor Length Reference (LLLL)	0150 to 1800 in 0001 increments						
Mid Drive Conveyor Length Reference (LLLL)	0200 to 2400 in 0001 increments						
End Drive Conveyor Length	1.50 ft (457 mm) to 18 ft (5486 mm) in 0.12" (0.31 mm) increments						
Mid Drive Conveyor Length	2.00 ft (610 mm) to 24 ft (7315 mm) in 0.12" (0.31 mm) increments						
Belt Travel	4.0" (88 mm) per revolution of pulley						
Maximum Belt Speed*	264 ft/minute (80.5 m/minute)						
Belt Take-up	0.38" (10 mm) of stroke = 0.75" (19 mm) of belt take-up						

Conveyor Width Reference (WW)	12	14	16	18	20	22	24
Conveyor Belt Width	12" (305 mm)	14" (356 mm)	16" (406 mm)	18" (457 mm)	20" (508 mm)	22" (559 mm)	24" (609 mm)
Maximum Conveyor Load* (See NOTE Below)	80 lb (36 kg)	80 lb (36 kg)	80 lb (36 kg)	80 lb (36 kg)	80 lb (36 kg)	80 lb (36 kg)	80 lb (36 kg)
End Drive Conveyor Startup Torque**	13 in-lb (1.5 Nm)	14 in-lb (1.6 Nm)	15 in-lb (1.7 Nm)	16 in-lb (1.8 Nm)	17 in-lb (1.9 Nm)	18 in-lb (2.0 Nm)	20 in-lb (2.3 Nm)
Mid Drive Conveyor Startup Torque**	15 in-lb (1.7 Nm)	16 in-lb (1.8 Nm)	17 in-lb (1.9 Nm)	18 in-lb (2.0 Nm)	19 in-lb (2.1 Nm)	20 in-lb (2.3 Nm)	22 in-lb (2.5 Nm)
End Drive Conveyor Length Reference (LLLL)	0150 to 1800 in 0001 increments						
Mid Drive Conveyor Length Reference (LLLL)	0200 to 2400 in 0001 increments						
End Drive Conveyor Length	1.50 ft (457 mm) to 18 ft (5486 mm) in 0.12" (0.31 mm) increments						
Mid Drive Conveyor Length	2.00 ft (610 mm) to 24 ft (7315 mm) in 0.12" (0.31 mm) increments						
Belt Travel	4.0" (88 mm) per revolution of pulley						
Maximum Belt Speed*	264 ft/minute (80.5 m/minute)						
Belt Take-up	0.38" (10 mm) of stroke = 0.75" (19 mm) of belt take-up						

* See Ordering and Specifications Catalog for details.

** Conveyor Startup Torque dependent on belt type and conveyor length.

Specifications

Center Drive Conveyor Specifications

Conveyor Width Reference (WW)	02	03	04	05	06	08	10
Conveyor Belt Width	1.75" (44 mm)	2.75" (70 mm)	3.75" (95 mm)	5" (127 mm)	6" (152 mm)	8" (203 mm)	10" (254 mm)
Maximum Conveyor Load* (See NOTE Below)	40 lb (18 kg)	50 lb (23 kg)	60 lb (27 kg)	75 lb (34 kg)	90 lb (41 kg)	105 lb (47 kg)	120 lb (54 kg)
Conveyor Startup Torque**	9 in-lb (1.0 Nm)	10 in-lb (1.1 Nm)	11 in-lb (1.2 Nm)	12 in-lb (1.4 Nm)	15 in-lb (1.7 Nm)	20 in-lb (2.3 Nm)	23 in-lb (2.6 Nm)
Conveyor Length Reference (LLLL)	0200 to 2400 in 0001 increments						
Conveyor Length	2.00 ft (457 mm) to 24 ft (7315 mm) in 0.12" (0.31 mm) increments						
Belt Travel	4.2" (107 mm) per revolution of pulley						
Maximum Belt Speed*	235 ft/minute (72 m/minute)						
Belt Take-up	1" (25 mm) of stroke = 2" (51 mm) of belt take-up (Center Drive Conveyors Only)						

Conveyor Width Reference (WW)	12	14	16	18	20	22	24
Conveyor Belt Width	12" (305 mm)	14" (356 mm)	16" (406 mm)	18" (457 mm)	20" (508 mm)	22" (559 mm)	24" (609 mm)
Maximum Conveyor Load* (See NOTE Below)	120 lb (54 kg)	120 lb (54 kg)	120 lb (54 kg)	120 lb (54 kg)	120 lb (54 kg)	120 lb (54 kg)	120 lb (54 kg)
Conveyor Startup Torque**	25 in-lb (2.8 Nm)	26 in-lb (2.9 Nm)	28 in-lb (3.2 Nm)	30 in-lb (3.4 Nm)	32 in-lb (3.6 Nm)	34 in-lb (3.8 Nm)	35 in-lb (4.0 Nm)
Conveyor Length Reference (LLLL)	0200 to 2400 in 0001 increments						
Conveyor Length	2.00 ft (457 mm) to 24 ft (7315 mm) in 0.12" (0.31 mm) increments						
Belt Travel	4.2" (107 mm) per revolution of pulley						
Maximum Belt Speed*	235 ft/minute (72 m/minute)						
Belt Take-up	1" (25 mm) of stroke = 2" (51 mm) of belt take-up (Center Drive Conveyors Only)						

* See Ordering and Specifications Catalog for details.

** Conveyor Startup Torque dependent on belt type and conveyor length.

Specifications

Flat Belt LPZ Conveyor Specifications

Conveyor Width Reference (WW)	02	03	04	05	06	08	10
Conveyor Belt Width	1.75" (44 mm)	2.75" (70 mm)	3.75" (95 mm)	5" (127 mm)	6" (152 mm)	8" (203 mm)	10" (254 mm)
Maximum Conveyor Load* (See NOTE Below)	30 lb (14 kg)	35 lb (16 kg)	42 lb (19 kg)	50 lb (23 kg)	60 lb (27 kg)	70 lb (32 kg)	80 lb (36 kg)
Conveyor Startup Torque**	4 in-lb (0.5 Nm)	5 in-lb (0.6 Nm)	6 in-lb (0.7 Nm)	8 in-lb (0.9 Nm)	10 in-lb (1.1 Nm)	12 in-lb (1.4 Nm)	14 in-lb (1.6 Nm)
Conveyor Length Reference (LLLL)	0200 to 1000 in 0001 increments						
Conveyor Section Length	2.00 ft (610 mm) to 10.00 ft (3048 mm) in 0.12" (0.31 mm) increments						
Belt Travel	4.0" (88 mm) per revolution of pulley						
Maximum Belt Speed*	264 ft/minute (80.5 m/minute)						
Belt Take-up	0.38" (10 mm) of stroke = 0.75" (19 mm) of belt take-up						

Conveyor Width Reference (WW)	12	14	16	18	20	22	24
Conveyor Belt Width	12" (305 mm)	14" (356 mm)	16" (406 mm)	18" (457 mm)	20" (508 mm)	22" (559 mm)	24" (609 mm)
Maximum Conveyor Load* (See NOTE Below)	80 lb (36 kg)	80 lb (36 kg)	80 lb (36 kg)	80 lb (36 kg)	80 lb (36 kg)	80 lb (36 kg)	80 lb (36 kg)
Conveyor Startup Torque**	15 in-lb (1.7 Nm)	16 in-lb (1.8 Nm)	17 in-lb (1.9 Nm)	18 in-lb (2.0 Nm)	19 in-lb (2.1 Nm)	20 in-lb (2.3 Nm)	22 in-lb (2.5 Nm)
Conveyor Length Reference (LLLL)	0200 to 1000 in 0001 increments						
Conveyor Section Length	2.00 ft (610 mm) to 10.00 ft (3048 mm) in 0.12" (0.31 mm) increments						
Belt Travel	4.0" (88 mm) per revolution of pulley						
Maximum Belt Speed*	264 ft/minute (80.5 m/minute)						
Belt Take-up	0.38" (10 mm) of stroke = 0.75" (19 mm) of belt take-up						

* See Ordering and Specifications Catalog for details.

** Conveyor Startup Torque dependent on belt type and conveyor length.

Specifications

Cleated Belt LPZ Conveyor Specifications

Conveyor Width Reference (WW)	02	03	04	05	06	08	10
Conveyor Belt Width	1.75" (44 mm)	2.75" (70 mm)	3.75" (95 mm)	5" (127 mm)	6" (152 mm)	8" (203 mm)	10" (254 mm)
Maximum Conveyor Load* (See NOTE Below)	30 lb (14 kg)	35 lb (16 kg)	42 lb (19 kg)	50 lb (23 kg)	60 lb (27 kg)	70 lb (32 kg)	80 lb (36 kg)
Conveyor Startup Torque**	4 in-lb (0.5 Nm)	5 in-lb (0.6 Nm)	6 in-lb (0.7 Nm)	8 in-lb (0.9 Nm)	10 in-lb (1.1 Nm)	12 in-lb (1.4 Nm)	14 in-lb (1.6 Nm)
Conveyor Length Reference (LLLL)	0200 to 1000 in 0001 increments						
Conveyor Section Length	2.00 ft (610 mm) to 10.00 ft (3048 mm) in 0.12" (0.31 mm) increments						
Total Conveyor Length							
Belt Travel	4.0" (88 mm) per revolution of pulley						
Maximum Belt Speed*	264 ft/minute (80.5 m/minute)						
Belt Take-up	0.38" (10 mm) of stroke = 0.75" (19 mm) of belt take-up						

Conveyor Width Reference (WW)	12	14	16	18	20	22	24
Conveyor Belt Width	12" (305 mm)	14" (356 mm)	16" (406 mm)	18" (457 mm)	20" (508 mm)	22" (559 mm)	24" (609 mm)
Maximum Conveyor Load* (See NOTE Below)	80 lb (36 kg)	80 lb (36 kg)	80 lb (36 kg)	80 lb (36 kg)	80 lb (36 kg)	80 lb (36 kg)	80 lb (36 kg)
Conveyor Startup Torque**	15 in-lb (1.7 Nm)	16 in-lb (1.8 Nm)	17 in-lb (1.9 Nm)	18 in-lb (2.0 Nm)	19 in-lb (2.1 Nm)	20 in-lb (2.3 Nm)	22 in-lb (2.5 Nm)
Conveyor Length Reference (LLLL)	0200 to 1000 in 0001 increments						
Conveyor Section Length	2.00 ft (610 mm) to 10.00 ft (3048 mm) in 0.12" (0.31 mm) increments						
Total Conveyor Length							
Belt Travel	4.0" (88 mm) per revolution of pulley						
Maximum Belt Speed*	264 ft/minute (80.5 m/minute)						
Belt Take-up	0.38" (10 mm) of stroke = 0.75" (19 mm) of belt take-up						

* See Ordering and Specifications Catalog for details.

** Conveyor Startup Torque dependent on belt type and conveyor length.

Specifications

iDrive Conveyor Specifications

Conveyor Width Reference (WWW)	02	03	04	05	06	08
Conveyor Belt Width	1.75" (44 mm)	2.75" (70 mm)	3.75" (95 mm)	5" (127 mm)	6" (152 mm)	8" (203 mm)
Maximum Conveyor Load	See iDrive Load Capacity Chart Below					
Conveyor Length Reference (LLLL)	0150 to 0800 in 0001 increments					
Conveyor Length	1.50 ft (457 mm) to 8 ft (2438 mm) in 0.12" (0.31 mm) increments					
Belt Travel	4.0" (88 mm) per revolution of spindle					
Maximum Belt Speed*	70 ft/minute (21 m/minute)					
Belt Take-up	0.38" (10 mm) of stroke = 0.75" (19 mm) of belt take-up					

Conveyor Width Reference (WWW)	10	12	14	16	18
Conveyor Belt Width	10" (254 mm)	12" (305 mm)	14" (356 mm)	16" (406 mm)	18" (457 mm)
Maximum Conveyor Load	See iDrive Load Capacity Chart Below				
Conveyor Length Reference (LLLL)	0150 to 0800 in 0001 increments				
Conveyor Length	1.50 ft (457 mm) to 8 ft (2438 mm) in 0.12" (0.31 mm) increments				
Belt Travel	4.0" (88 mm) per revolution of spindle				
Maximum Belt Speed*	70 ft/minute (21 m/minute)				
Belt Take-up	0.38" (10 mm) of stroke = 0.75" (19 mm) of belt take-up				

* See Ordering and Specifications Catalog for details.

iDrive Motor Specifications

Output Power	25 watt	25 watt
Motor Voltage	24 volt DC, 0.8 amp	24 volt DC, 0.8 amp
Transformer Voltage	100-240 VAC, 50/60 Hz	100-240 VAC, 50/60 Hz
Gearmotor Ratio	23:1	66:1
Motor Type	Brushless DC	Brushless DC
Belt Speeds	7-70 Ft./Min., 5-50 Ft./Min.	2.4-24 Ft./Min., 1.7-17 Ft./Min
Duty Cycle	Non-Continuous Duty	Non-Continuous Duty
Index Capacity	Up to 30 per Minute	Up to 30 per Minute

Specifications

iDrive Load Capacity (lbs)

		7 - 70 Ft./Min. FOR BELT TYPE 09						
		LENGTH						
		2	3	4	5	6	7	8
WIDTH	2	13	13	13	13	12	12	0
	3	13	13	13	13	12	12	0
	4	11	11	11	11	11	10	0
	5	11	11	10	10	10	10	0
	6	10	10	10	10	9	9	0
	8	9	9	9	8	8	8	0
	10-18	0	0	0	0	0	0	0

		5 - 50 Ft./Min. FOR BELT TYPE 09						
		LENGTH						
		2	3	4	5	6	7	8
WIDTH	2	24	24	24	24	24	24	0
	3	24	24	24	24	24	24	0
	4	22	22	22	22	22	22	0
	5	22	22	22	21	21	21	0
	6	21	21	21	21	21	20	0
	8	20	20	20	20	19	19	0
	10	17	17	17	16	16	0	0
	12	15	15	14	0	0	0	0
	14-18	0	0	0	0	0	0	0

		2.4 - 24 Ft./Min. FOR BELT TYPE 09						
		LENGTH						
		2	3	4	5	6	7	8
WIDTH	2	25	25	25	25	25	25	25
	3	25	25	25	25	25	25	25
	4	25	25	25	25	25	25	25
	5	25	25	25	25	25	25	25
	6	25	25	25	25	25	25	25
	8	25	25	25	25	25	25	25
	10	25	25	25	25	25	0	0
	12	25	25	25	0	0	0	0
	14	25	25	25	0	0	0	0
	16	25	25	25	0	0	0	0
	18	25	25	0	0	0	0	0

		1.7 - 17 Ft./Min. FOR BELT TYPE 09						
		LENGTH						
		2	3	4	5	6	7	8
WIDTH	2	25	25	25	25	25	25	25
	3	25	25	25	25	25	25	25
	4	25	25	25	25	25	25	25
	5	25	25	25	25	25	25	25
	6	25	25	25	25	25	25	25
	8	25	25	25	25	25	25	25
	10	25	25	25	25	25	0	0
	12	25	25	25	0	0	0	0
	14	25	25	25	0	0	0	0
	16	25	25	25	0	0	0	0
	18	25	25	0	0	0	0	0

Specifications

iDrive Load Capacity (lbs) (continued)

		7 - 70 Ft./Min. FOR DOUBLE CARCASS BELT TYPE 05						
		LENGTH						
		2	3	4	5	6	7	8
WIDTH	2	9	9	8	8	8	8	0
	3	9	9	5	8	8	8	0
	4	7	7	7	7	6	6	0
	5	6	6	6	6	6	6	0
	6	6	6	6	6	5	5	0
	8-18	0	0	0	0	0	0	0

		5 - 50 Ft./Min. FOR DOUBLE CARCASS BELT TYPE 05						
		LENGTH						
		2	3	4	5	6	7	8
WIDTH	2	20	20	20	20	20	20	0
	3	20	20	20	20	20	20	0
	4	18	18	18	18	18	18	0
	5	18	18	18	17	17	17	0
	6	17	17	17	17	17	17	0
	8	16	16	16	16	15	15	0
	10	13	13	13	12	12	0	0
	12	11	11	10	0	0	0	0
	14-18	0	0	0	0	0	0	0

		2.4 - 24 Ft./Min. FOR DOUBLE CARCASS BELT TYPE 05						
		LENGTH						
		2	3	4	5	6	7	8
WIDTH	2	25	25	25	25	25	25	25
	3	25	25	25	25	25	25	25
	4	25	25	25	25	25	25	25
	5	25	25	25	25	25	25	25
	6	25	25	25	25	25	25	25
	8	25	25	25	25	25	25	25
	10	25	25	25	25	25	0	0
	12	25	25	25	25	0	0	0
	14-18	25	25	25	25	0	0	0

		1.7 - 17 Ft./Min. FOR DOUBLE CARCASS BELT TYPE 05						
		LENGTH						
		2	3	4	5	6	7	8
WIDTH	2	25	25	25	25	25	25	25
	3	25	25	25	25	25	25	25
	4	25	25	25	25	25	25	25
	5	25	25	25	25	25	25	25
	6	25	25	25	25	25	25	25
	8	25	25	25	25	25	25	25
	10	25	25	25	25	25	0	0
	12	25	25	25	0	0	0	0
	14-18	25	25	0	0	0	0	0

Specifications

iDrive Load Capacity (lbs) (continued)

		7 - 70 Ft./Min. FOR SINGLE PLY BELT TYPES 19, 53, 72, 73 AND 76						
		LENGTH						
		2	3	4	5	6	7	8
WIDTH	2	19	19	19	19	19	19	0
	3	19	19	19	19	19	19	0
	4	17	17	17	17	17	17	0
	5	17	17	17	17	17	16	0
	6	16	16	16	16	16	16	0
	8	15	15	15	15	15	15	0
	10	12	12	12	12	12	0	0
	12	10	10	10	0	0	0	0
14-18	0	0	0	0	0	0	0	

		5 - 50 Ft./Min. FOR SINGLE PLY BELT TYPES 19, 53, 72, 73 AND 76						
		LENGTH						
		2	3	4	5	6	7	8
WIDTH	2	25	25	25	25	25	25	25
	3	25	25	25	25	25	25	25
	4	25	25	25	25	25	25	25
	5	25	25	25	25	25	25	25
	6	25	25	25	25	25	25	25
	8	25	25	25	25	25	25	25
	10	23	23	23	23	23	0	0
	12	21	21	21	0	0	0	0
14-18	16	16	0	0	0	0	0	

		2.4 - 24 Ft./Min. FOR SINGLE PLY BELT TYPES 19, 53, 72, 73 AND 76						
		LENGTH						
		2	3	4	5	6	7	8
WIDTH	2	25	25	25	25	25	25	25
	3	25	25	25	25	25	25	25
	4	25	25	25	25	25	25	25
	5	25	25	25	25	25	25	25
	6	25	25	25	25	25	25	25
	8	25	25	25	25	25	25	25
	10	25	25	25	25	25	0	0
	12	25	25	25	0	0	0	0
14-18	25	25	0	0	0	0	0	

		1.7 - 17 Ft./Min. FOR SINGLE PLY BELT TYPES 19, 53, 72, 73 AND 76						
		LENGTH						
		2	3	4	5	6	7	8
WIDTH	2	25	25	25	25	25	25	25
	3	25	25	25	25	25	25	25
	4	25	25	25	25	25	25	25
	5	25	25	25	25	25	25	25
	6	25	25	25	25	25	25	25
	8	25	25	25	25	25	25	25
	10	25	25	25	25	25	0	0
	12	25	25	25	0	0	0	0
14-18	25	25	0	0	0	0	0	

Specifications

iDrive Load Capacity (lbs) (continued)

		7 - 70 Ft./Min. FOR ALL OTHER BELT TYPES						
		LENGTH						
		2	3	4	5	6	7	8
WIDTH	2	6	5	5	5	5	5	0
	3	6	5	5	5	5	5	0
	4-18	0	0	0	0	0	0	0

		5 - 50 Ft./Min. FOR ALL OTHER BELT TYPES						
		LENGTH						
		2	3	4	5	6	7	8
WIDTH	2	17	17	17	17	16	16	0
	3	17	17	17	17	16	16	0
	4	15	15	15	15	15	14	0
	5	15	15	14	14	14	14	0
	6	14	14	14	14	13	13	0
	8	13	13	13	12	12	12	0
	10	10	10	9	9	9	0	0
	12-18	0	0	0	0	0	0	0

		2.4 - 24 Ft./Min. FOR ALL OTHER BELT TYPES						
		LENGTH						
		2	3	4	5	6	7	8
WIDTH	2	25	25	25	25	25	25	25
	3	25	25	25	25	25	25	25
	4	25	25	25	25	25	25	25
	5	25	25	25	25	25	25	25
	6	25	25	25	25	25	25	25
	8	25	25	25	25	25	25	25
	10	25	25	25	25	25	0	0
	12	25	25	25	0	0	0	0
	14-18	25	25	0	0	0	0	0

		1.7 - 17 Ft./Min. FOR ALL OTHER BELT TYPES						
		LENGTH						
		2	3	4	5	6	7	8
WIDTH	2	25	25	25	25	25	25	25
	3	25	25	25	25	25	25	25
	4	25	25	25	25	25	25	25
	5	25	25	25	25	25	25	25
	6	25	25	25	25	25	25	25
	8	25	25	25	25	25	25	25
	10	25	25	25	25	25	0	0
	12	25	25	25	0	0	0	0
	14-18	25	25	0	0	0	0	0

Specifications

iDrive Load Capacity (lbs) (continued)

		2.4 - 24 Ft./Min. FOR NOSE BAR BELTS						
		LENGTH						
		2	3	4	5	6	7	8
WIDTH	2	20	20	20	20	20	20	0
	3	20	20	20	20	20	20	0
	4	18	18	18	18	18	18	0
	5	18	18	18	18	18	17	0
	6	17	17	17	17	17	17	0
	8	16	16	16	16	16	15	0
	10	13	13	13	12	12	0	0
	12	11	11	11	0	0	0	0
14-18	0	0	0	0	0	0	0	

		1.7 - 17 Ft./Min. FOR NOSE BAR BELTS						
		LENGTH						
		2	3	4	5	6	7	8
WIDTH	2	25	25	25	25	25	25	0
	3	25	25	25	25	25	25	0
	4	25	25	25	25	25	25	0
	5	25	25	25	25	25	25	0
	6	25	25	25	25	25	25	0
	8	25	25	25	25	25	25	0
	10	25	25	25	25	25	0	0
	12	25	25	25	0	0	0	0
14-18	25	25	0	0	0	0	0	

NOTE

Maximum conveyor loads based on:

- Non-accumulating product
- Product moving towards gearmotor
- Conveyor being mounted horizontal

⚠ WARNING



LPZ Series Conveyors are not reversible. Reversing creates pinch points which can cause severe injury.

DO NOT REVERSE LPZ SERIES CONVEYORS.

NOTE

Conveyor *MUST* be mounted straight, flat, and level within confines of conveyor. Use a level (Figure 7, item 1) for setup.

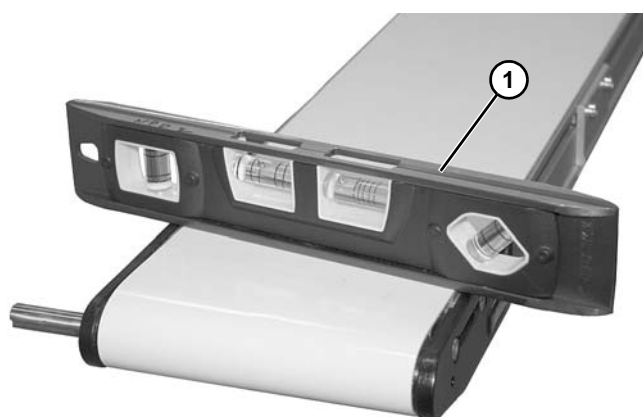

Figure 7

Required Tools

- Hex-key wrenches: 4 mm, 5 mm, 6 mm
- Level
- Torque wrench

Recommended Installation Sequence

- Assemble conveyor (if required)
- Attach mounting brackets to conveyor
- Attach conveyor to stands
- Install return rollers on conveyor (optional)
- Mount gearmotor mounting package (See accessory instructions)
- Attach guides/accessories. (See “Service Parts” section beginning on page 60 for details.)

Conveyors Up to 12 ft (3658 mm)

No assembly is required. Install mounting brackets and return rollers. Refer to “Mounting Brackets” on page 21 and “Return Rollers” on page 22.

Conveyors Longer Than 12 ft (3658 mm)

1. Locate and arrange conveyor sections by section labels (Figure 8, item 1).

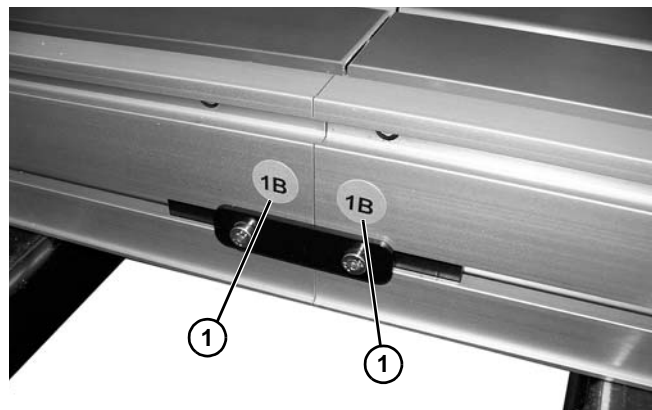



Figure 8

2. On tension end of the conveyor, identified with  a label (Figure 9, item 1), push in head plate assembly (Figure 9, item 2):
 - a. On both sides of conveyor, loosen and move cam tracking assemblies (Figure 9, item 3) (if equipped) away from head plates.
 - b. Loosen fastening screws (Figure 9, item 4) and push head plate assembly inward.

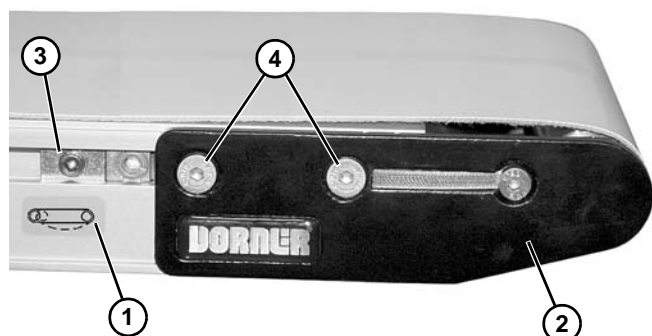

Figure 9

Installation

3. Roll out conveyor belt and place conveyor frame sections (**Figure 10, item 1**) into belt loop.

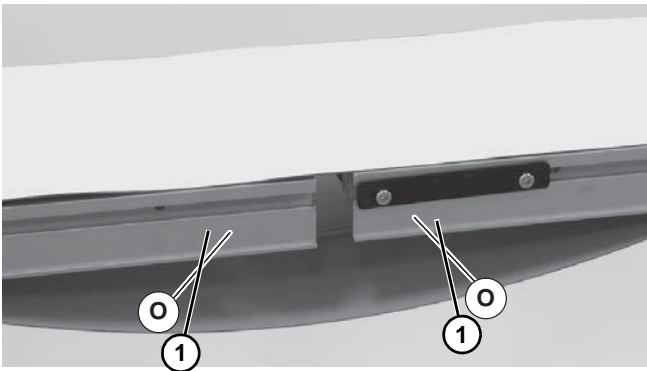

Figure 10

4. Join conveyor sections and install frame connector plates (**Figure 11, item 1**) or connector/mount brackets (**Figure 11, item 2**) and screws (**Figure 11, item 3**) on both sides as indicated. Tighten screws to 60 in-lb (7 Nm).

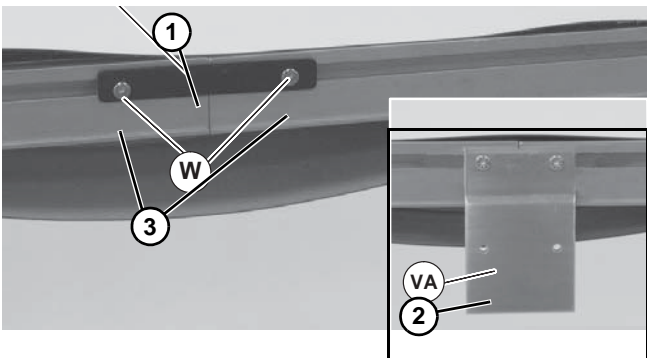

Figure 11

5. Tension conveyor belt. For proper tensioning, refer to “Conveyor Belt Tensioning” on page 42”.
6. Install mounting brackets and return rollers. Refer to “Mounting Brackets” on page 21 and “Return Rollers” on page 22.
7. If equipped with cam tracking assemblies, reposition and adjust belt tracking. Refer to “Conveyor Belt Tracking” on page 44.

Knuckles

1. Roll out conveyor belt. Loosen four screws (**Figure 12, item 1**) on both sides of knuckle (**Figure 12, item 2**). Slide frame (**Figure 12, item 3**) into knuckle (**Figure 12, item 2**). Tighten screws (**Figure 12, item 1**) to 60 in-lb (7 N-m) on both sides of conveyor.

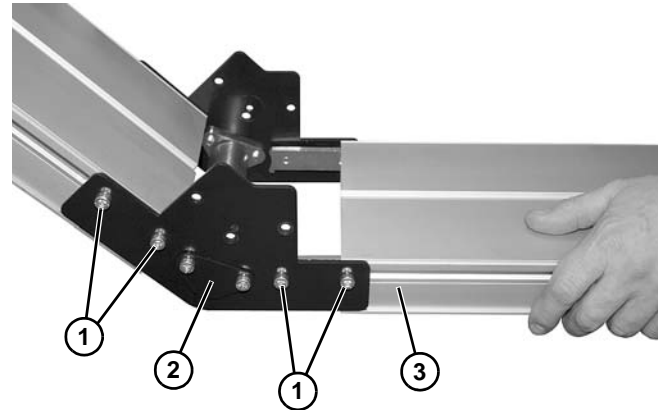

Figure 12

2. Join conveyor sections and install frame connector plates (**Figure 11, item 1**) or connector/mount brackets (**Figure 11, item 2**) and screws (**Figure 11, item 3**) on both sides as indicated. Tighten screws to 60 in-lb (7 Nm).

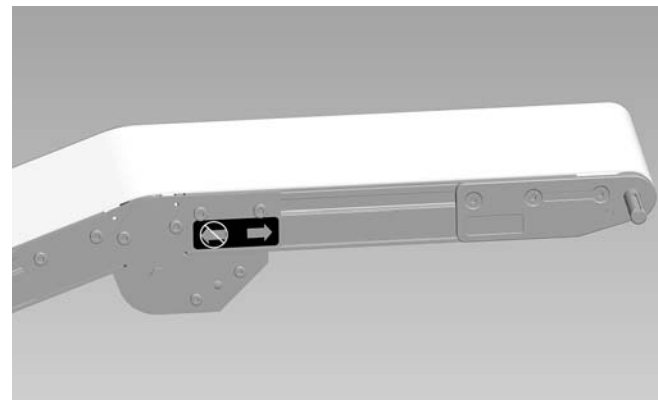

Figure 13

NOTE

Upper knuckle must be assembled to conveyor with belt flow in direction of arrow.

Mounting Brackets

1. Locate brackets. Exploded views shown in Figure 14 & Figure 15.

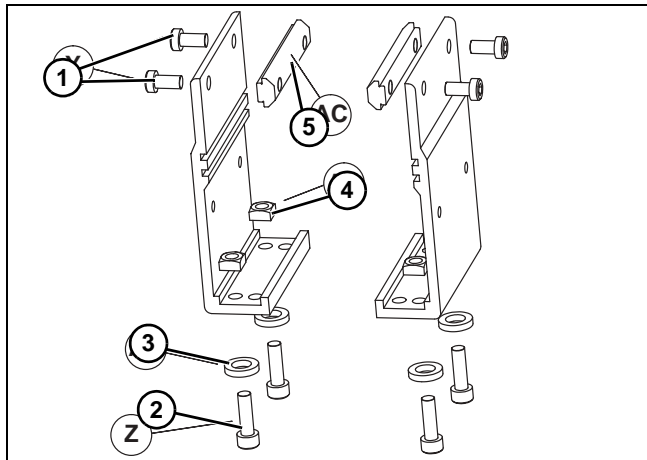

Figure 14

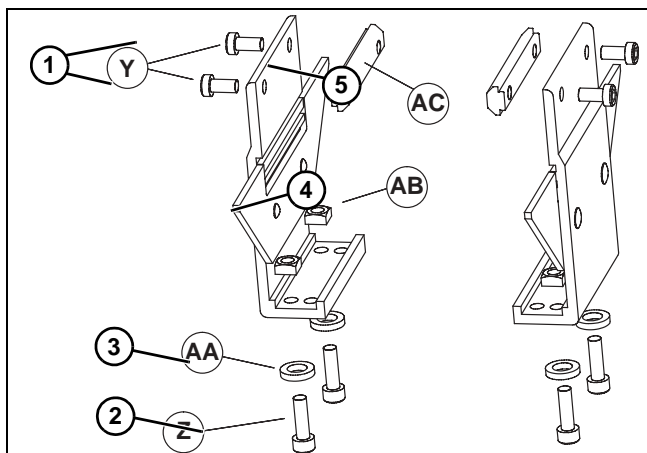

Figure 15

2. Remove screws (Figure 14, item 1 & 2) & (Figure 15, item 1 & 2), washers (Figure 14, item 3) & (Figure 15, item 3), nuts (Figure 14, item 4) & (Figure 15, item 4), and T-bars (Figure 14, item 5) & (Figure 15, item 5) from brackets.

3. Insert T-bars (Figure 14, item 5) & (Figure 15, item 5) into conveyor side slots (Figure 16, item 1). Fasten brackets (Figure 16, item 2) to conveyor with mounting screws (Figure 16, item 3).

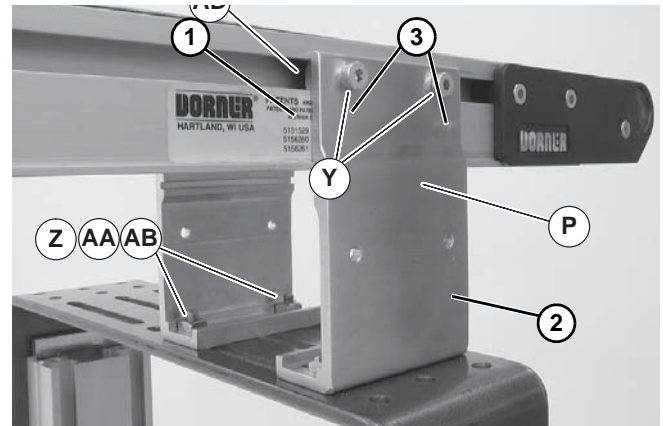

Figure 16

NOTE

Mounting brackets for flat belt conveyors shown.

4. Fasten brackets to support stand with mounting screws (Figure 14, item 2), washers (Figure 14, item 3) and nuts (Figure 14, item 4).
5. Tighten all screws to 60 in-lb (7 Nm).

Installation

Return Rollers

Cleated Belt and 2–6" (51–152 mm) Wide Flat Belt Conveyors

1. Locate return rollers. Exploded views shown in Figure 17 & Figure 18.

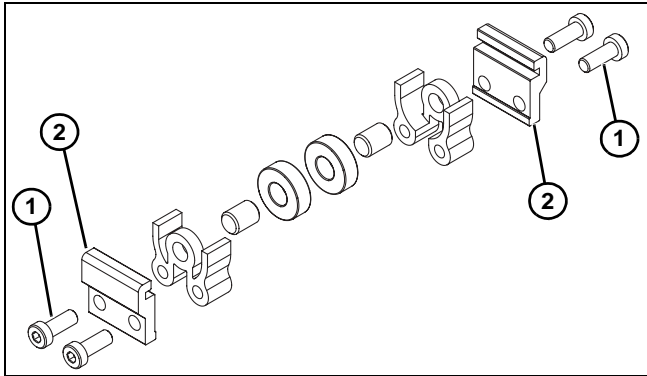

Figure 17

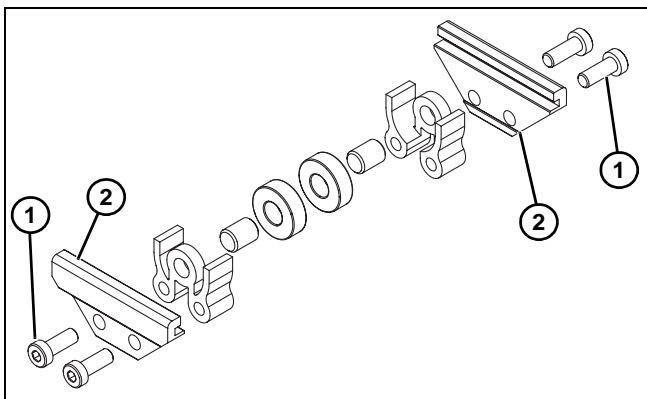

Figure 18

2. Remove screws (Figure 17, item 1) & (Figure 18, item 1) and clips (Figure 17, item 2) & (Figure 18, item 2) from roller assembly.
3. Install roller assemblies (Figure 19, item 1) as shown. Tighten screws (Figure 19, item 2) to 60 in-lb (7 Nm).

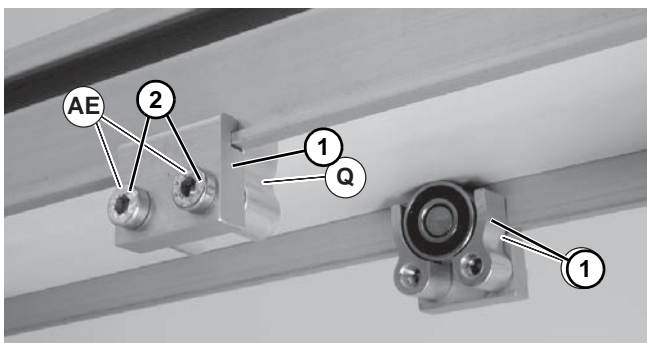

Figure 19

8–24" (203–610 mm) Wide Flat Belt Conveyors

1. Locate return rollers. Exploded view shown in Figure 20.

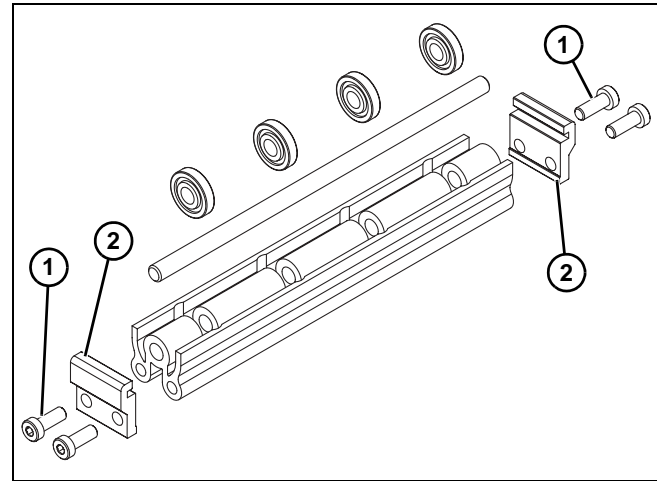

Figure 20

2. Remove screws (Figure 20, item 1) and clips (Figure 20, item 2) from roller assembly.
3. Install roller assembly as shown (Figure 21, item 1). Tighten screws (Figure 21, item 2) to 60 in-lb (7 Nm).

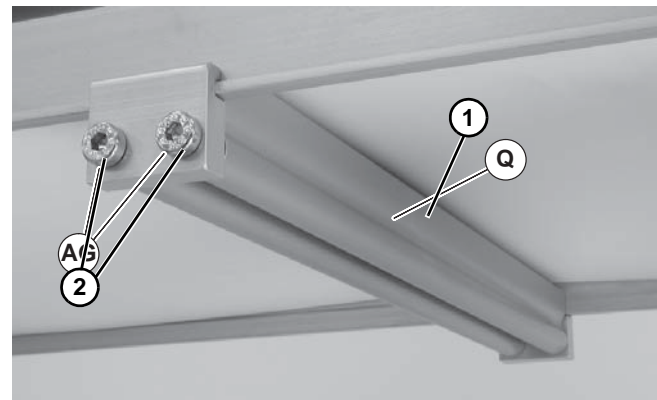



Figure 21

iDrive Wiring

⚠ WARNING

Motor will start immediately once power is supplied. Exposed moving parts can cause severe injury. LOCK OUT POWER before wiring to avoid accidental startup.

The 2200 series iDrive is available in 2 models:

- A. Cover Mounted Controls
- B. Cover Mounted Controls with Remote Start/Stop Cable

Cover Mounted Controls with 115 volt Power Supply

1. No wiring is required. Attach quick disconnect end (**Figure 22, item 1**) of power supply (**Figure 22, item 2**) to power jack (**Figure 22, item 3**).

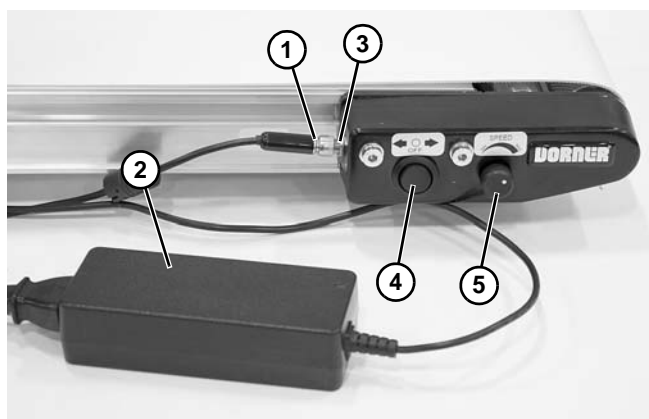

Figure 22

2. Select conveyor running direction with directional switch (**Figure 22, item 4**).
3. Select conveyor speed with speed control knob (**Figure 22, item 5**).

NOTE

1. *Start Stop Application: Maximum start stop cycles are 30 per minute.*
2. *Reversing Applications: Do not reverse the motor direction when running. Make sure the motor is stopped before reversing signal is given.*

Cover Mounted Controls with Remote Start/Stop Cable

1. Connect power supply to cover. See previous section.
2. Select conveyor running direction with directional switch (**Figure 23, item 1**).

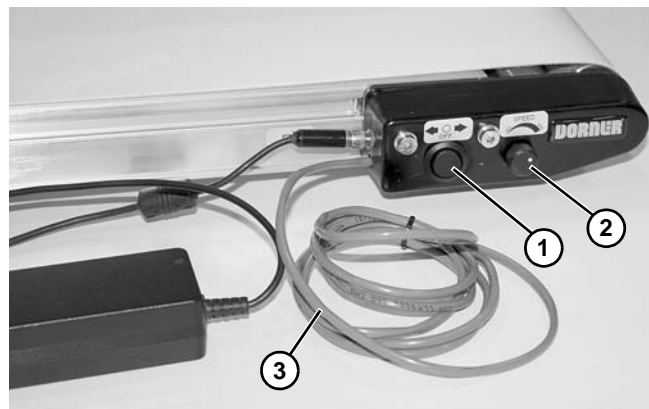

Figure 23

3. Select conveyor speed with speed control knob (**Figure 23, item 2**).
4. Remote start/stop cable (**Figure 23, item 3**) comes with wire nut over remote leads to allow test running conveyor.
5. Remove wire nut and connect red and black wires to switching device. Switching device minimum rating 1 amp @ 24 VDC.

NOTE

1. *Start Stop Application: Maximum start stop cycles are 30 per minute.*
2. *Reversing Applications: Do not reverse the motor direction when running. Make sure the motor is stopped before reversing signal is given.*

Installation

Cover Mounted Controls with Customer Provided Power Supply

1. Locate the male disconnect plug (**Figure 24, item 1**) provided.



Figure 24

2. Wire and solder DC power to the two terminals of the provided DC power plug. Wire +VDC to the short lug (**Figure 25, item 1**) and -VDC to the long lug (**Figure 25, item 2**).

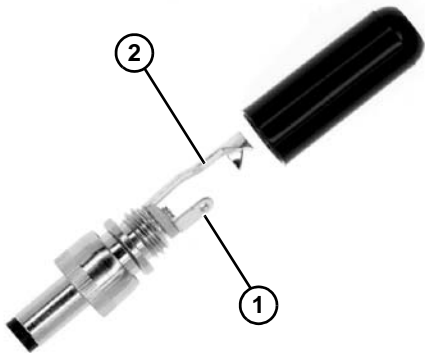

Figure 25

3. Required power is 24VDC, 2 amps minimum.

Cover Mounted Controls with Photo Eye Option

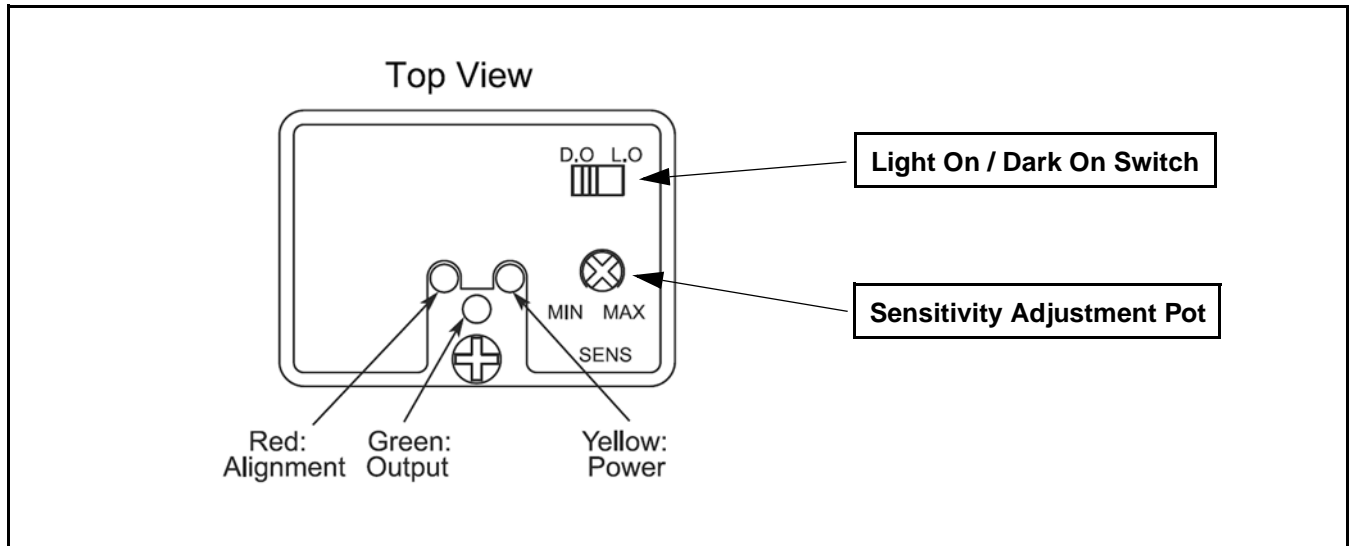

Figure 26

1. Mount photo eye and reflector bracket to side of conveyor close to zone to be sensed.
2. Connect power supply to AC input power, photo eye plug, and to conveyor drive cover. Adjust conveyor running direction switch to off (center) position. Photo eye should have yellow LED lit.
3. Adjust reflector to align with red beam emitted from photo eye and be at a 90 degree +/- 15 degree angle to photo eye face. When reflector is properly aligned, photo eye will have yellow and red LED lit. Green LED indicates output relay is energized.
4. Adjust photo eye sensitivity by placing a sample object in the beam. Unscrew clear cover on photo eye top and slowly turn the gain adjustment clockwise (see caution below concerning pot adjustment) until the green (output) LED activates (assuming the sensor is in the light operate mode). Note the position and remove the sample object. Now continue turning the sensitivity setting clockwise to find the position where the green LED activates from the background reflection. Reset the sensitivity midway between the two positions.
5. Photo eye comes preset to Light-On operation which causes the conveyor to run when the sensed zone is clear and stop when the sensed zone is blocked. For Dark-On operation move selector to D.O. position (**Figure 26**).
6. Select conveyor running direction with directional switch (**Figure 23, item 1**). If Dark-On operation is selected, temporarily block photo eye to energize conveyor.
7. Select conveyor speed with speed control knob (**Figure 23, item 2**).

CAUTION

Adjustment pots are 3/4 turn devices. Any resistance encountered while adjusting these pots indicates you have reached the adjustment limit stop. Turning past stop will damage the sensor.

Installation

Guide Clips

1. Install guide clip assembly (**Figure 27, item 1**) into conveyor t-slot (**Figure 27, item 2**) as shown.

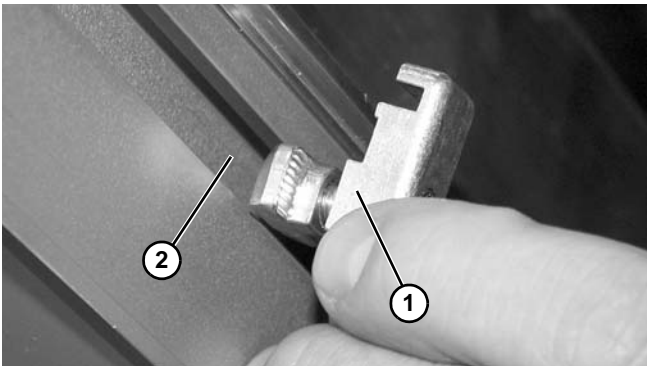

Figure 27

2. Tighten screw (**Figure 28, item 1**) making sure t-bar (**Figure 28, item 2**) rotates and engages inside of t-slot.

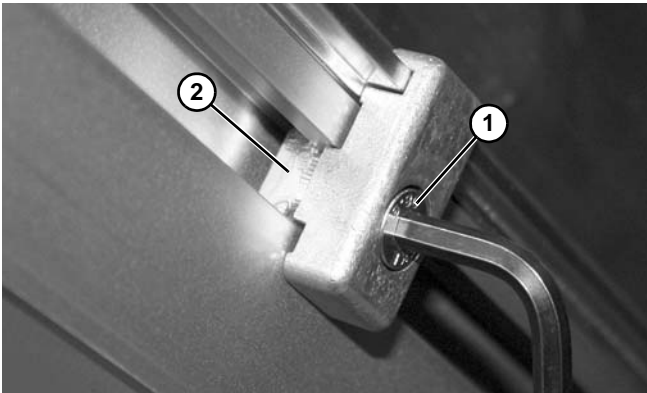

Figure 28

Adjustable Guides

1. Install guide bracket assembly (**Figure 29, item 1**) into the conveyor t-slot (**Figure 29, item 2**).

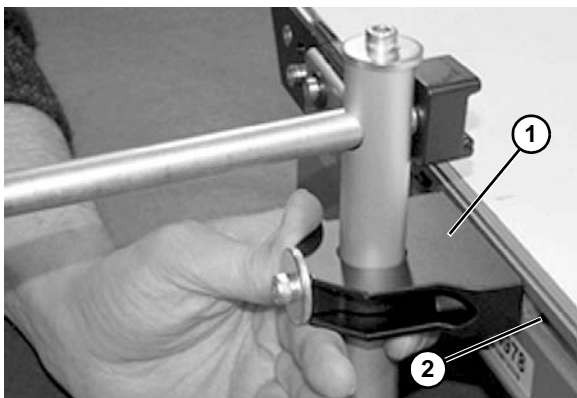

Figure 29

2. Tighten screws (**Figure 30, item 1**) making sure t-nut (**Figure 30, item 2**) rotates and engages inside of the t-slot.

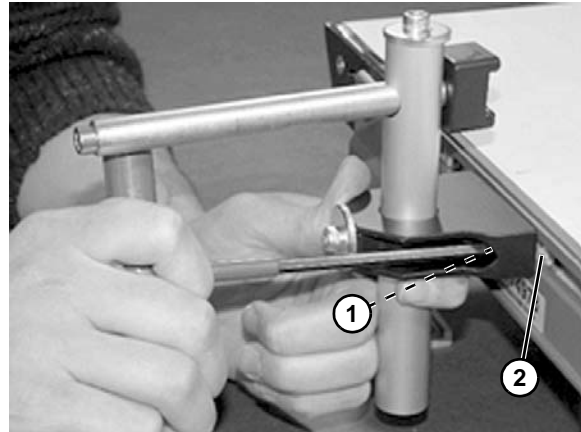

Figure 30

3. Loosen screw (**Figure 31, item 1**) on end of shaft (**Figure 31, item 2**) to remove clip (**Figure 32, item 1**).

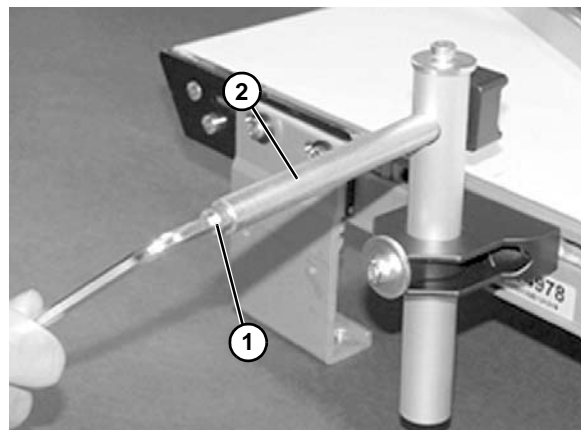

Figure 31

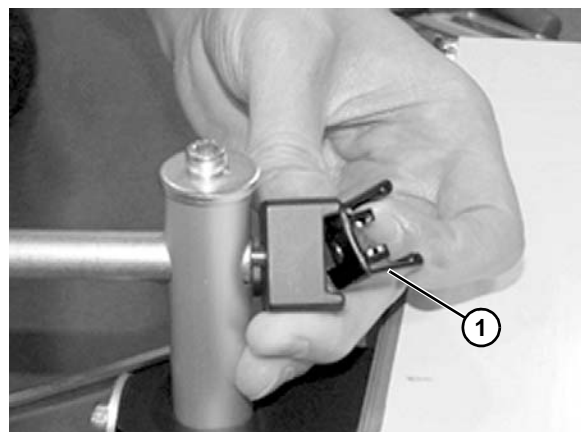

Figure 32

Installation

4. Snap clip (**Figure 33, item 1**) onto guide rail (**Figure 33, item 2**).

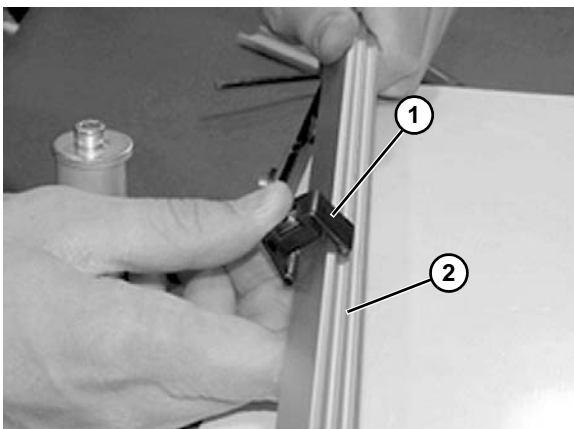

Figure 33

5. Reassemble clip (**Figure 34, item 1**) and attach to shaft (**Figure 34, item 2**). Tighten screw (**Figure 31, item 1**) on end of shaft.

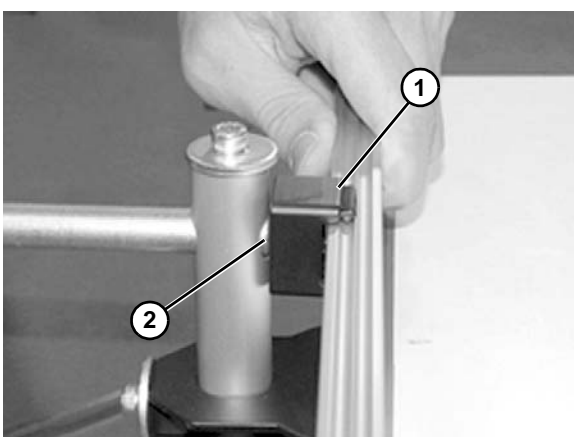

Figure 34

6. Adjust rail width with top screw (**Figure 35, item 1**).

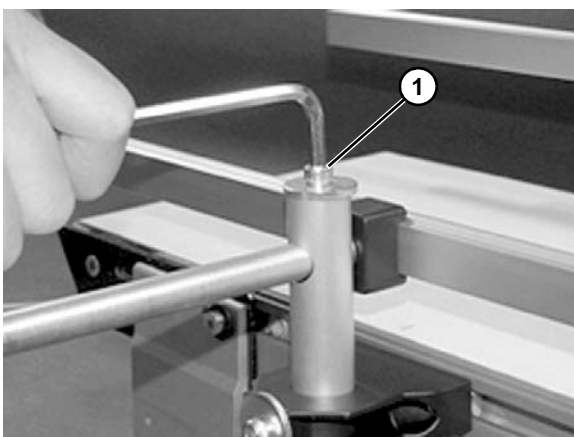

Figure 35

7. Adjust rail height with lower screw (**Figure 36, item 1**).

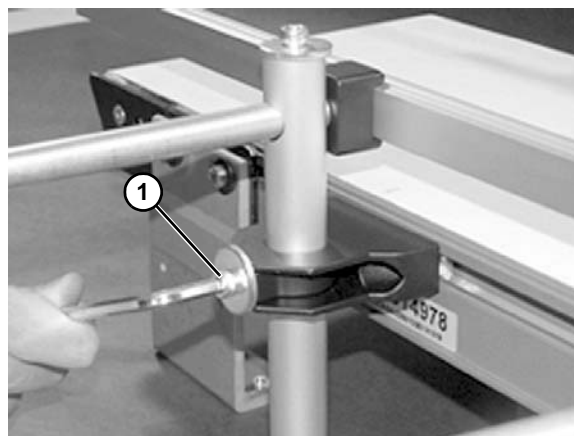

Figure 36

Notes

Preventive Maintenance and Adjustment

Required Tools

Standard Tools

- Hex-key wrenches:
 - 2.5 mm, 4 mm, 5 mm, 6 mm

Checklist

- Keep service parts on hand (see “Service Parts” section for recommendations)
- Keep supply of belt cleaner
- Clean entire conveyor and knurled pulley while disassembled
- Replace worn or damaged parts

Lubrication

No lubrication is required. Replace bearings if worn.

Maintaining Conveyor Belt

Troubleshooting

Inspect conveyor belt for:

- Surface cuts or wear
- Stalling or slipping
- Damage to V-guide

Surface cuts and wear indicate:

- Sharp or heavy parts impacting belt
- Jammed parts
- Improperly installed bottom wipers (if installed)
- Accumulated dirt in wipers (if installed)
- Foreign material inside the conveyor
- Improperly positioned accessories
- Bolt-on guiding is pinching belt

Stalling or slipping indicates:

- Excessive load on belt
- Conveyor belt or drive timing belt are not properly tensioned
- Worn knurl or impacted dirt on drive pulley
- Intermittent jamming or drive train problems

Damage to V-guide indicates:

- Twisted or damaged conveyor frame
- Dirt impacted on pulleys
- Excessive or improper side loading

Cleaning

Use Dorner Belt Cleaner. Mild soap and water may also be used. Do not soak the belt.

For /05 woven polyester and /06 black anti-static belts, use a bristled brush to improve cleaning.

Conveyor Belt Replacement

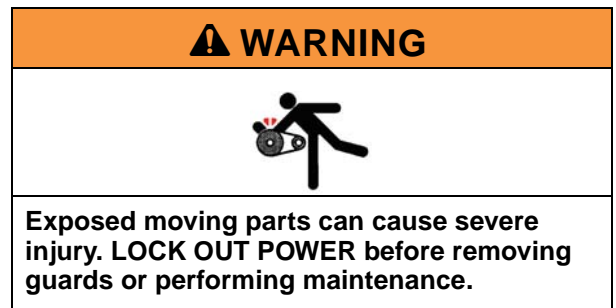

Conveyor Belt Replacement Sequence

- Release tension
- Remove old conveyor belt:
 - Conveyor without Stands or Gearmotor Mounting Package
 - Conveyor with Stands and Gearmotor Mounting Package
- Install new conveyor belt
- Tension conveyor belt

Preventive Maintenance and Adjustment

Belt Removal for End Drive and iDrive Conveyors

Without Stands or Gearmotor Mounting Package

1. If equipped, remove return rollers and guiding and accessories from one side of conveyor.
2. On tension end of the conveyor, identified with  a label (**Figure 37, item 1**), push in head plate assembly (**Figure 37, item 2**):
 - a. On both sides of conveyor, loosen and move cam tracking assemblies (**Figure 37, item 3**) (if equipped) away from head plates.
 - b. Loosen fastening screws (**Figure 37, item 4**) and push head plate assembly inward.

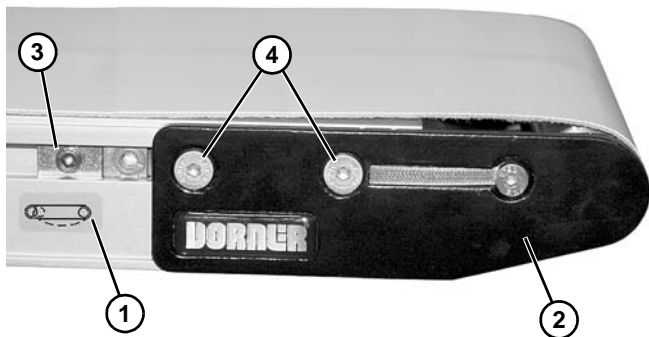



Figure 37

3. Remove conveyor belt.

With Stands and Gearmotor Mounting Package

⚠ WARNING

<p>Removing mounting brackets without support under gearmotor will cause conveyor to tip, causing severe injury. PROVIDE SUPPORT UNDERNEATH THE GEARMOTOR WHEN CHANGING THE BELT</p>

1. Place temporary support stands (**Figure 38, item 1**) at both ends of the conveyor. Place an additional support stand (**Figure 38, item 2**) under the drive motor, if equipped. See WARNING.

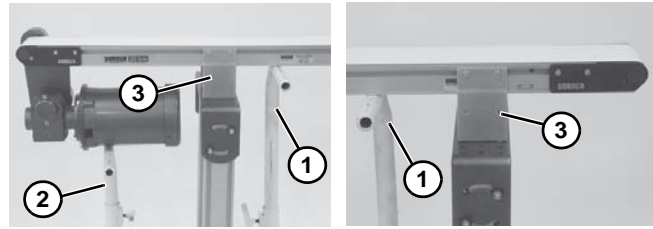

Figure 38

2. Remove mounting brackets (**Figure 38, item 3**) from one side of conveyor. (Reverse steps 3 & 4 of “Mounting Brackets” section beginning on page 21.) If equipped with heavy load drive package, remove brackets from side opposite drive cover (**Figure 39, item 1**).
3. If equipped, remove return rollers and guiding and accessories from side opposite drive cover (**Figure 39, item 1**).

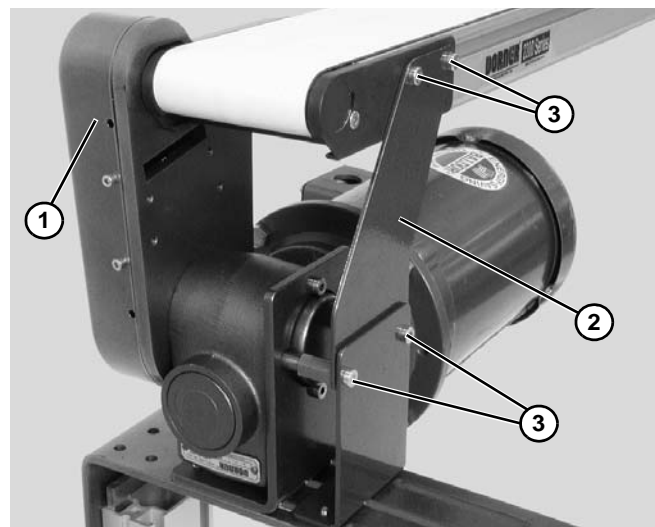



Figure 39

4. If equipped with heavy load drive package, remove drive support bracket (**Figure 39, item 2**): Remove bracket screws (**Figure 39, item 3**) then remove bracket (**Figure 39, item 2**).

Preventive Maintenance and Adjustment

5. On tension end of the conveyor, identified with  a label (**Figure 40, item 1**), push in head plate assembly (**Figure 40, item 2**):
 - a. On both sides of conveyor, loosen and move cam tracking assemblies (**Figure 40, item 3**) (if equipped) away from head plates.
 - b. Loosen fastening screws (**Figure 40, item 4**) and push head plate assembly inward.

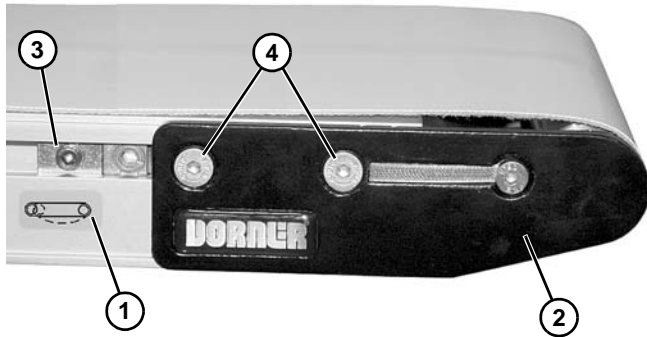

Figure 40

6. Remove belt (**Figure 41, item 1**) from conveyor.



Figure 41

Belt Removal for Center Drive Conveyors

1. If equipped, remove return rollers and guiding and accessories from one side of conveyor.
2. Loosen corner screws (**Figure 42, item 1**) on each side of the drive module (**Figure 42, item 2**).

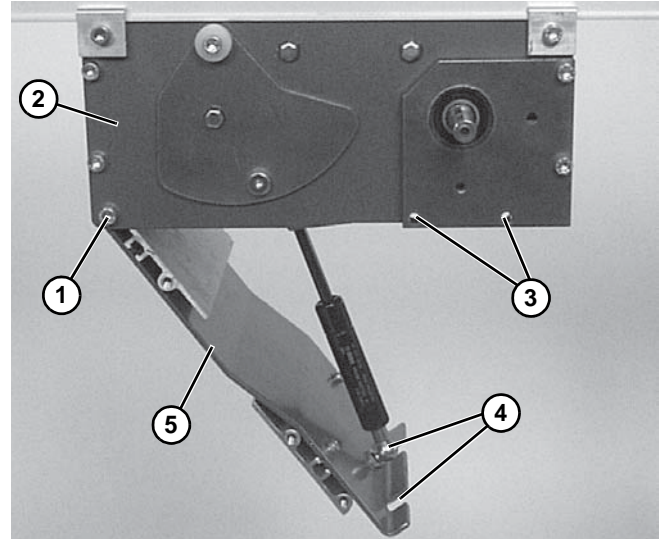



Figure 42

3. Remove tension door screws (**Figure 42, item 3**) on each side of the drive module.
4. Using finger grip holes (**Figure 42, item 4**), open the tension door (**Figure 42, item 5**) to release conveyor belt tension.
5. On tension end of the conveyor, identified with  a label (**Figure 43, item 1**), push in head plate assembly (**Figure 43, item 2**):
 - a. On both sides of conveyor, loosen and move cam tracking assemblies (**Figure 43, item 3**) (if equipped) away from head plates.
 - b. Loosen fastening screws (**Figure 43, item 4**) and push head plate assembly inward.

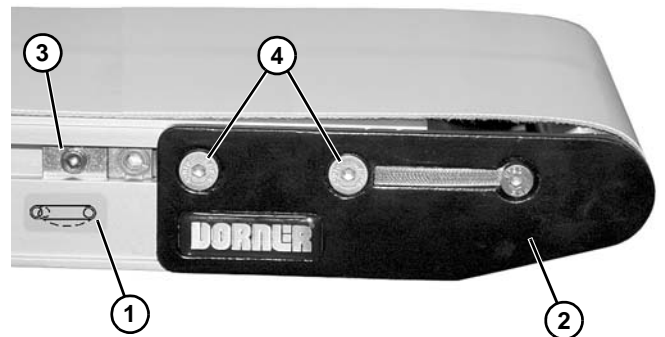

Figure 43

Preventive Maintenance and Adjustment

- If not equipped with stands, skip to step 9.
- Place temporary support stands (**Figure 44, item 1**) at both ends of the conveyor.

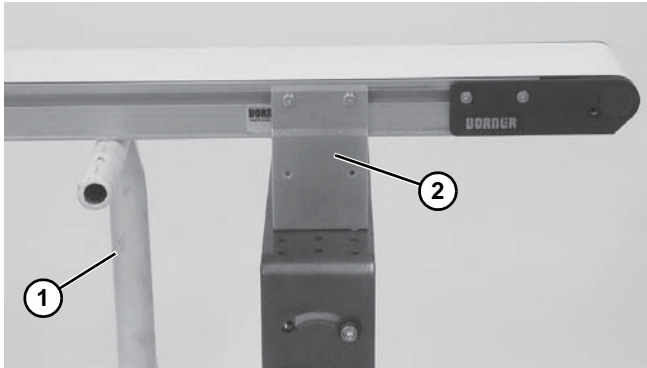

Figure 44

- Remove mounting brackets (**Figure 44, item 2**) from one side of conveyor. (Reverse steps 3 & 4 of “Mounting Brackets” on page 21.)
- Remove conveyor belt from conveyor ends. See NOTE.

NOTE

On conveyors 4-ft (1219 mm) and shorter by 8" (203 mm) and wider, it is be necessary to remove the drive module at the same time the conveyor belt is removed. See “Drive Module Removal” on page 33.

- Proceed to “Drive Module Removal” on page 33 and “Belt Removal from Drive Module” on page 34.

Gearmotor Mounting Package Removal

- Remove cover screws (**Figure 45, item 1**) and remove cover (**Figure 45, item 2**).

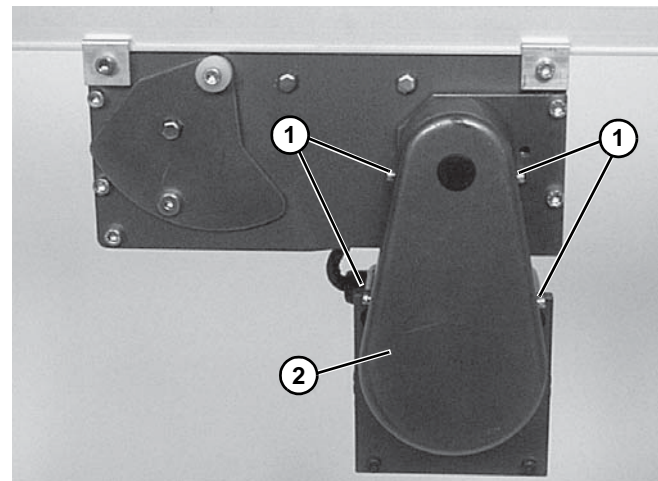

Figure 45

NOTE

Figure 37 shows a vertically mounted gearmotor. Horizontally mounted gearmotor is similar.

- Loosen belt tensioner (**Figure 46, item 1**) then remove timing belt (**Figure 46, item 2**).

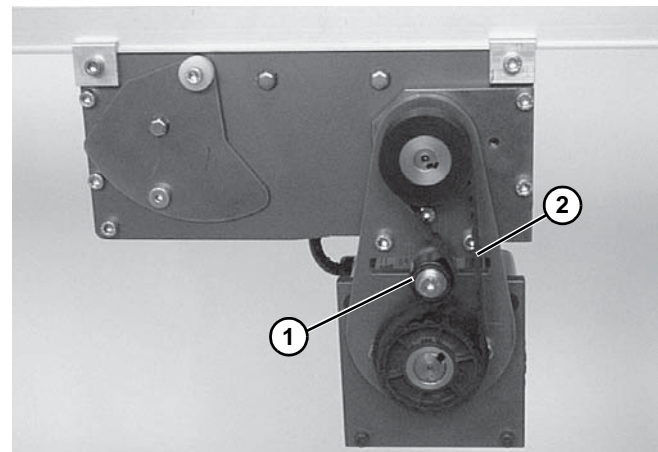

Figure 46

Preventive Maintenance and Adjustment

NOTE

If the timing belt does not slide over the pulley flange, loosen the driven pulley set screws (Figure 47, item 1) and remove the pulley (Figure 47, item 2) with the belt (Figure 47, item 3).

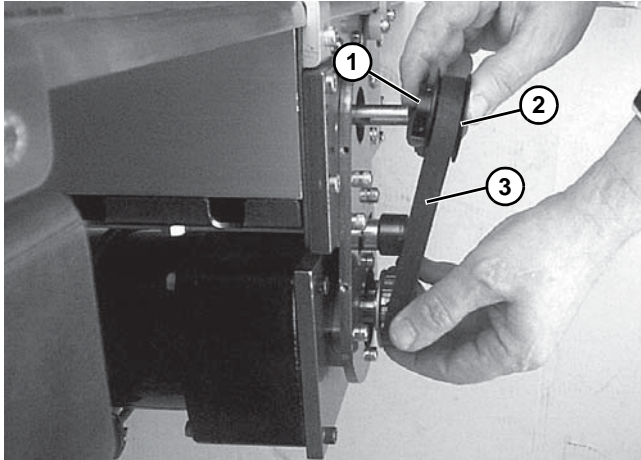

Figure 47

3. Remove four mounting screws (Figure 48, item 1) and remove gearmotor.

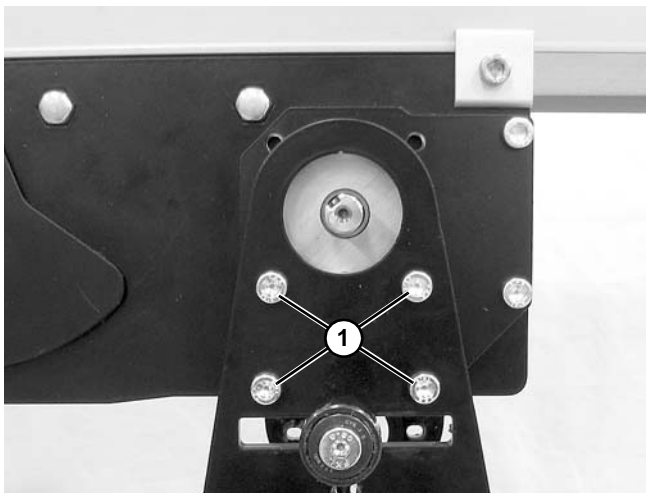

Figure 48

Drive Module Removal

WARNING



Removing drive module without support under the module may lead to personal injury.

PROVIDE SUPPORT UNDERNEATH THE DRIVE MODULE BEFORE REMOVING THE MODULE.

NOTE

If desired, mark position of drive module on conveyor before removal.

1. Place temporary support (Figure 49, item 1) underneath the drive module.

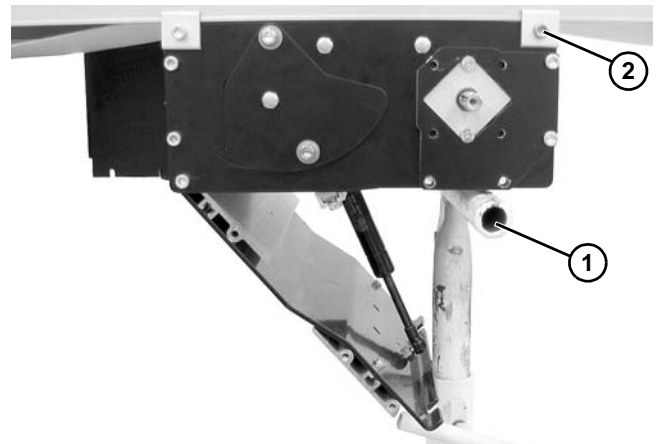

Figure 49

2. Loosen clamp screws (Figure 49, item 2) on each corner of the module. Remove the module.

Preventive Maintenance and Adjustment

Belt Removal from Drive Module

1. Remove screws (Figure 50, item 1) and remove spindle bearing block (Figure 50, item 2).

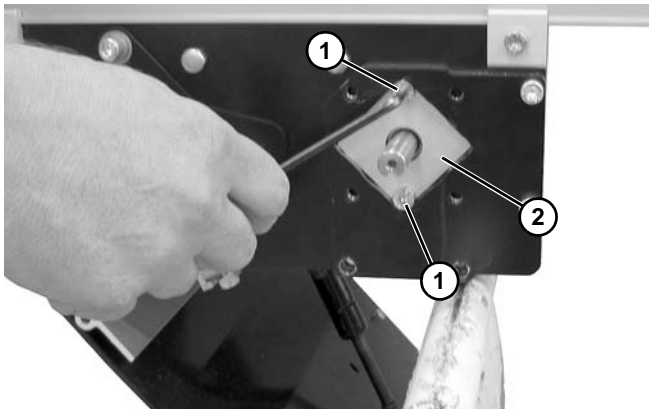

Figure 50

2. Remove drive pulley (Figure 51, item 1).

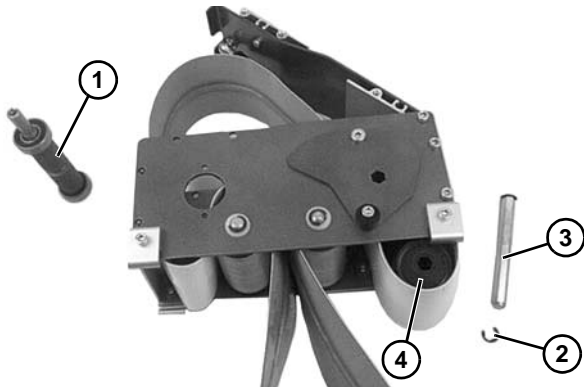

Figure 51



Figure 52

3. Remove grooved idler pulley:
 - a. For 2" (44 mm), 3" (70 mm) or 4" (95 mm) wide conveyor, detach E-ring clip (Figure 51, item 2). Remove pulley shaft (Figure 51, item 3) and remove pulley (Figure 51, item 4).
 - b. For 5" (127 mm) or wider conveyor, depress both sides of spring-loaded shaft and remove pulley (Figure 52, item 5).
4. Remove the conveyor belt.

Belt Removal for Mid Drive Conveyors

⚠ WARNING



SEVERE HAZARD!

LOCK OUT POWER before removing guards or performing maintenance. Exposed moving parts can cause serious injury.

1. Remove belt tension. See "Conveyor Belt Replacement" on page 29 for releasing belt tension.
2. Remove two screws (Figure 53, item 1) from bottom of mid drive assembly (Figure 53, item 2).

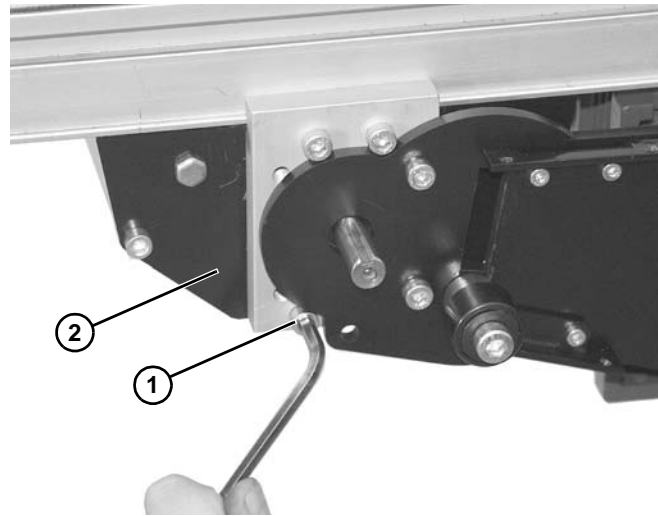

Figure 53

3. Lower and remove mid drive module (Figure 54, item 1) from belt (Figure 54, item 2).

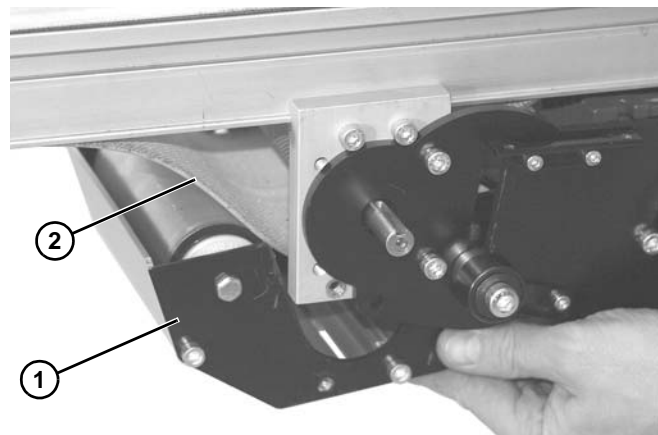

Figure 54

Preventive Maintenance and Adjustment

- Remove belt (**Figure 55, item 1**) from conveyor frame.



Figure 55

- Installation of new belt is the reverse order of removal.

Belt Removal for LPZ Conveyors

⚠ WARNING
<p>Removing mounting brackets without support under gearmotor will cause conveyor to tip, causing severe injury. PROVIDE SUPPORT UNDERNEATH THE GEARMOTOR WHEN CHANGING THE BELT</p>

- Place temporary support stands (**Figure 56, item 1**) at both ends of the conveyor. Place an additional support stand (**Figure 56, item 2**) under the drive motor (**Figure 56, item 3**), if equipped. See WARNING.

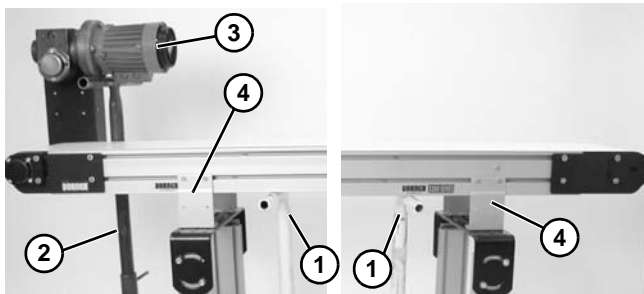



Figure 56

- Remove mounting brackets (**Figure 56, item 4**) from one side of conveyor. (Reverse steps 2 & 3 of “Mounting Brackets” section on page 21).
- If equipped, remove return rollers and guiding and accessories from one side of conveyor.

- On tension end of the conveyor, identified with  a label (**Figure 57, item 1**), push in head plate assembly (**Figure 57, item 2**):
 - On both sides of conveyor, loosen and move cam tracking assemblies (**Figure 57, item 3**) (if equipped) away from head plates.
 - Loosen fastening screws (**Figure 57, item 4**) and push head plate assembly inward.

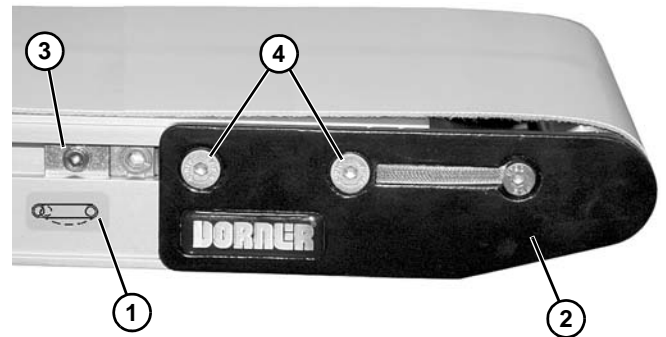

Figure 57

Cleated Belt Conveyors

- If equipped with a lower knuckle, remove screws (**Figure 58, item 1**) and remove guards (**Figure 58, item 2**) on both sides of knuckle.

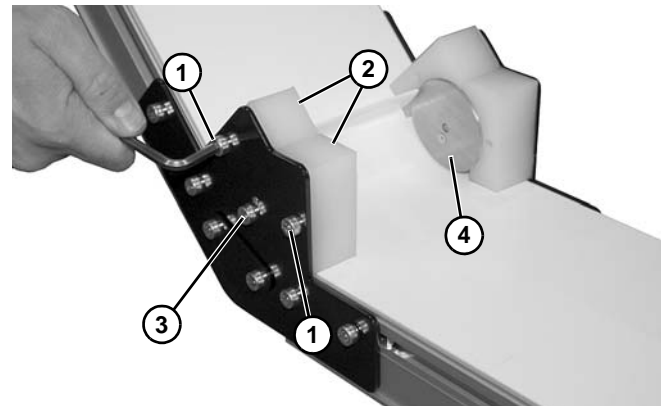

Figure 58

- Remove screws (**Figure 58, item 3**) and remove roller bearing assembly (**Figure 58, item 4**) on both sides of knuckle.

Preventive Maintenance and Adjustment

3. If equipped with an upper knuckle, remove screws (**Figure 59, item 1**) and remove guard (**Figure 59, item 2**) on both sides of knuckle.

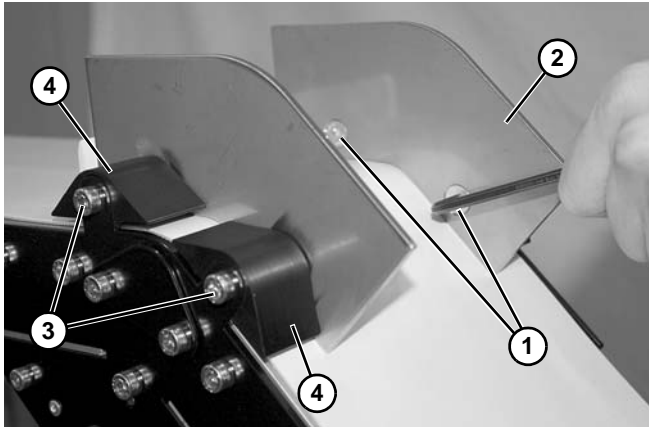

Figure 59

4. Remove screws (**Figure 59, item 3**) and remove spacers (**Figure 59, item 4**) on both sides of knuckle.
5. Remove screws (**Figure 60, item 1**) and remove guard (**Figure 60, item 2**) on both sides of knuckle.

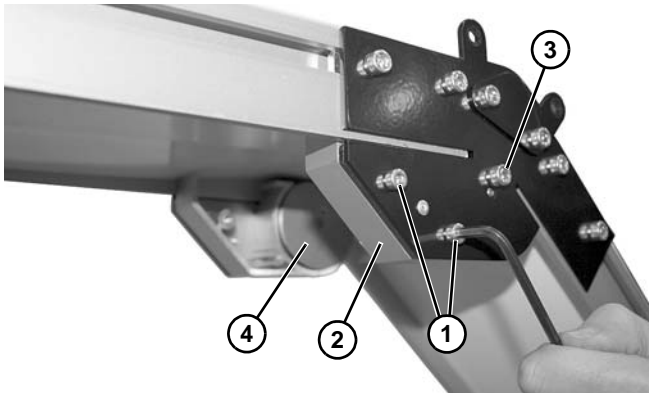

Figure 60

6. Remove screw (**Figure 60, item 3**) and remove roller bearing assembly (**Figure 60, item 4**) on both sides of knuckle.
7. Remove belt from conveyor.

Flat Belt Conveyors

1. Remove screws (**Figure 61, item 1**) on both sides of conveyor.

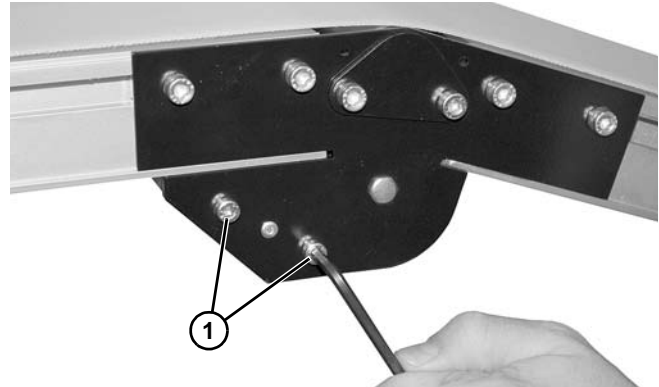

Figure 61

2. Remove guard (**Figure 62, item 1**).

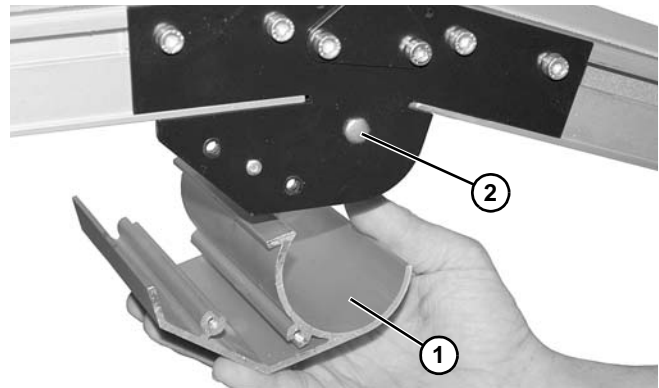

Figure 62

3. Remove idler pulley:
 - a. For 2" (44 mm) through 4" (95 mm) wide conveyors, remove E-ring clip (**Figure 63, item 1**) and washer (**Figure 63, item 2**) from one side. Remove pulley shaft (**Figure 63, item 3**) and pulley (**Figure 63, item 4**).

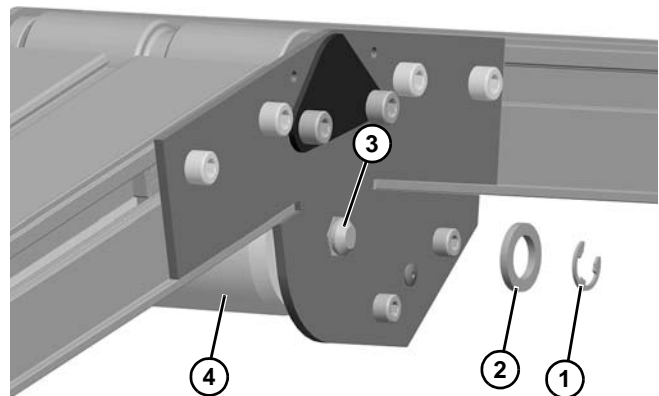

Figure 63

Preventive Maintenance and Adjustment

- b. For 5" (127 mm) or wider conveyor, push spring-loaded shaft ends (**Figure 64, item 1**) inward. Remove roller (**Figure 64, item 2**).

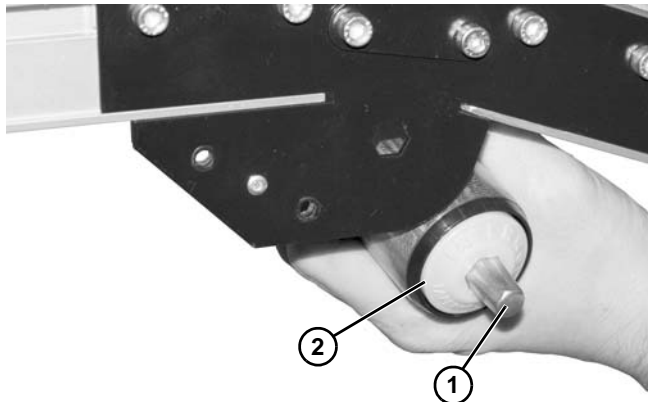

Figure 64

4. Remove belt from conveyor.

Belt Installation for End Drive and iDrive Conveyors

Without Stands or Gearmotor Mounting Package

1. Orient belt so splice leading fingers (**Figure 65, item 1**) point in the direction of belt travel as identified by the conveyor directional label (**Figure 65, item 2**).

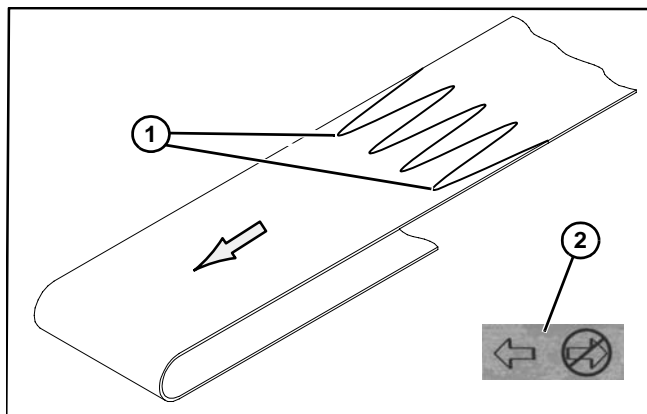

Figure 65

2. Slide belt onto the conveyor frame assembly.
3. Tension belt. Refer to "Conveyor Belt Tensioning" on page 42.
4. If equipped, install return rollers and guiding.

With Stands and Gearmotor Mounting Package

⚠ WARNING

Removing mounting brackets without support under gearmotor will cause conveyor to tip, causing severe injury. PROVIDE SUPPORT UNDERNEATH THE GEARMOTOR WHEN CHANGING THE BELT

1. Ensure temporary support stands (**Figure 66, item 1**) are placed at both ends of the conveyor. Place an additional support stand under the drive motor (**Figure 66, item 2**), if equipped. See WARNING.

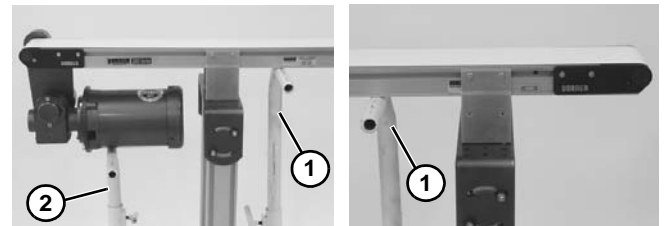

Figure 66

2. Orient belt so splice leading fingers (**Figure 65, item 1**) point in the direction of belt travel as identified by the conveyor directional label (**Figure 65, item 2**).
3. Install belt (**Figure 67, item 1**) on conveyor. Lift conveyor slightly to avoid pinching belt on temporary support stands.



Figure 67

4. Re-install conveyor mounting brackets. Refer to "Mounting Brackets" beginning on page 21, steps 3 through 5.

Preventive Maintenance and Adjustment

- If equipped with a heavy load drive package, install drive support bracket (**Figure 68, item 1**).

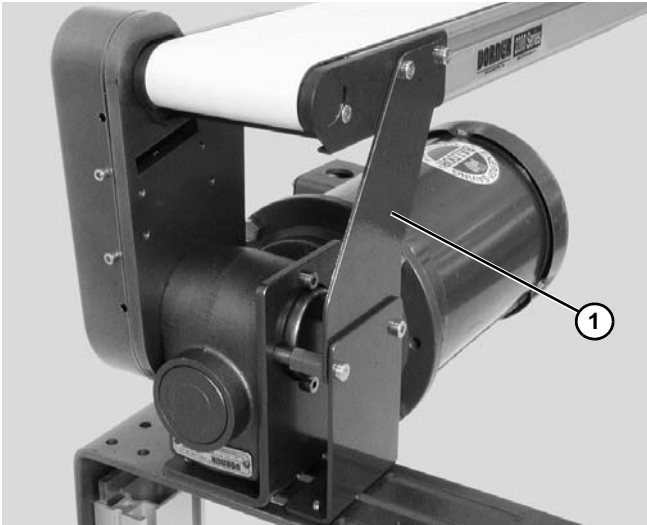

Figure 68

- Tension belt. Refer to “Conveyor Belt Tensioning” on page 42.
- If equipped, install return rollers and guiding.

Belt Installation for Center Drive Conveyors

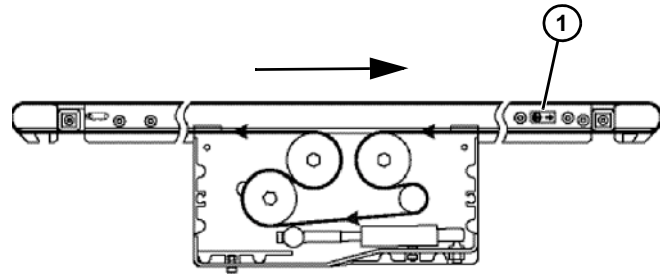

Figure 69

IMPORTANT

On a center drive conveyors, belt travel direction is identified by an arrow decal on the side of the conveyor (**Figure 69, item 1**) & (**Figure 70, item 1**).



Figure 70

NOTE

It is necessary to replace the drive module at the same time the conveyor belt is replaced on conveyors 4-foot (1219 mm) and shorter by 8" (203 mm) and wider.

- Orient the conveyor belt so that the splice leading fingers (**Figure 71, item 1**) point in the direction of belt travel, indicated by the label (**Figure 70, item 1**).

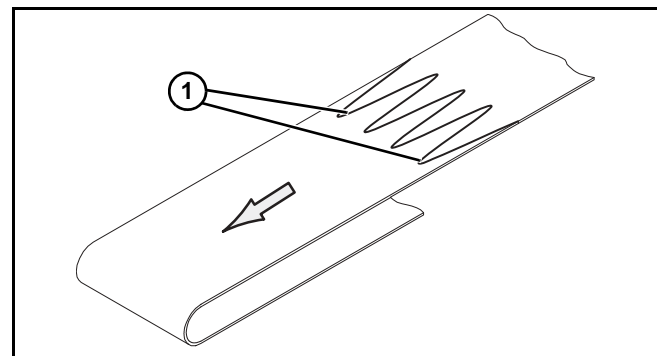

Figure 71

Preventive Maintenance and Adjustment

- Place loop of belt (**Figure 72, item 1**) into the drive module between top idler pulleys (**Figure 72, item 2**).

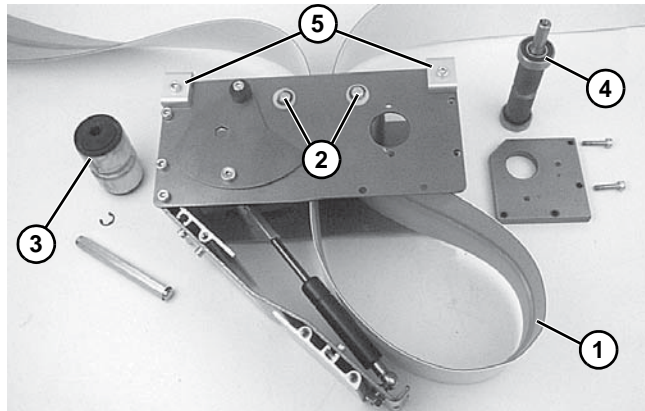

Figure 72

- Place grooved idler pulley (**Figure 72, item 3**) into the belt loop and install it in the drive module. Refer to “Belt Removal from Drive Module” on page 34 and reverse step 3.
- Place drive pulley (**Figure 72, item 4**) into the belt loop and install it in the drive module. Refer to “Belt Removal from Drive Module” on page 34 and reverse steps 1 and 2. Tighten screws (**Figure 50, item 1**) to 60 in-lb (6.8 Nm).
- Install the drive module onto the conveyor and attach clamps (**Figure 72, item 5**) in each corner. Tighten screws to 60 in-lb (6.8 Nm).
- Route and install the belt over both ends of the conveyor.
- On conveyors with stands, re-install conveyor mounting brackets. Refer to “Mounting Brackets” on page 21, steps 3 through 5.
- Adjust the conveyor tensioning end. See “Conveyor Belt Tensioning” on page 42.

⚠ WARNING



**Tension door closes quickly, may cause injury.
KEEP FINGERS CLEAR OF TENSION DOOR.**

- Carefully close the drive module tension door (**Figure 73, item 1**). See WARNING.

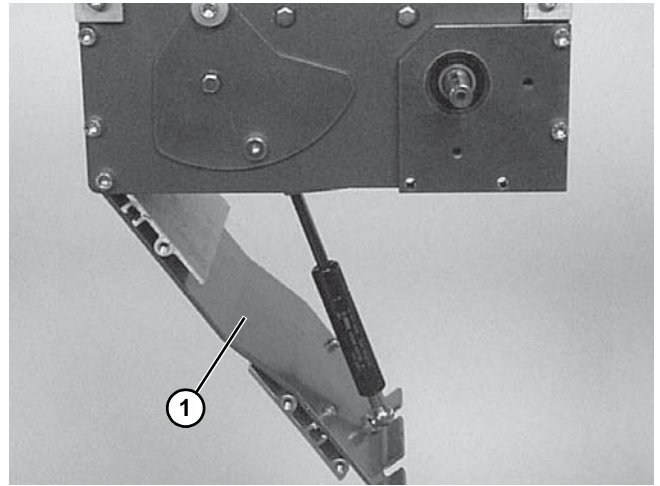

Figure 73

- Tighten corner screws (**Figure 74, item 1**) on each side of the drive module to 80 in-lb (9 Nm).

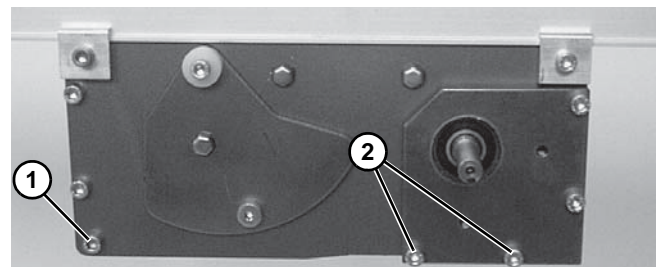

Figure 74

- If equipped, re-install the gearmotor mounting package. Reverse steps of “Gearmotor Mounting Package Removal” on page 32.
- Re-install tension door screws (**Figure 74, item 2**) on each side of the module. Tighten screws to 60 in-lb (6.8 Nm).

NOTE

*With vertically mounted gearmotors, tension door screws (**Figure 74, item 2**) are installed on one side when the gearmotor mounting package is installed.*

- If equipped, replace guiding.

Preventive Maintenance and Adjustment

Belt Installation for LPZ Conveyors

⚠ WARNING



Removing mounting brackets without support under gearmotor will cause conveyor to tip, causing severe injury. PROVIDE SUPPORT UNDERNEATH THE GEARMOTOR WHEN CHANGING THE BELT

1. Ensure temporary support stands (Figure 56, item 1) are placed at both ends of the conveyor. Place an additional support stand (Figure 56, item 2) under the drive motor (Figure 56, item 3), if equipped. See WARNING.
2. Orient belt so splice leading fingers (Figure 75, item 1) point in the direction of belt travel as identified by the conveyor directional label (Figure 75, item 2).

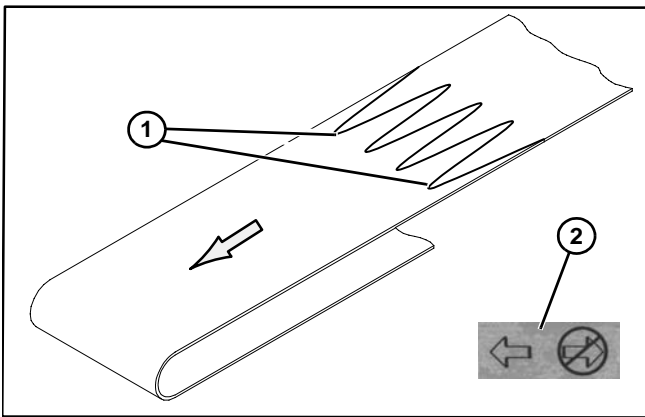

Figure 75

3. Slide belt onto the conveyor frame assembly.

Cleated Belt Conveyors

1. If equipped with an upper knuckle, install roller bearing assembly (Figure 76, item 1) into knuckle plate (Figure 76, item 2) with screws (Figure 76, item 3) on both sides of conveyor.

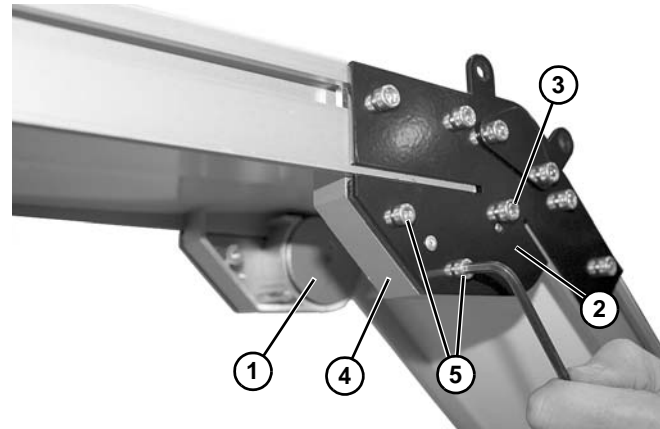

Figure 76

2. Install guard (Figure 76, item 4) on both sides of conveyor with screws (Figure 76, item 5). Tighten screws to 25 in-lb (3 Nm).
3. Install spacers (Figure 77, item 1) on both sides of conveyor with screws (Figure 77, item 2).

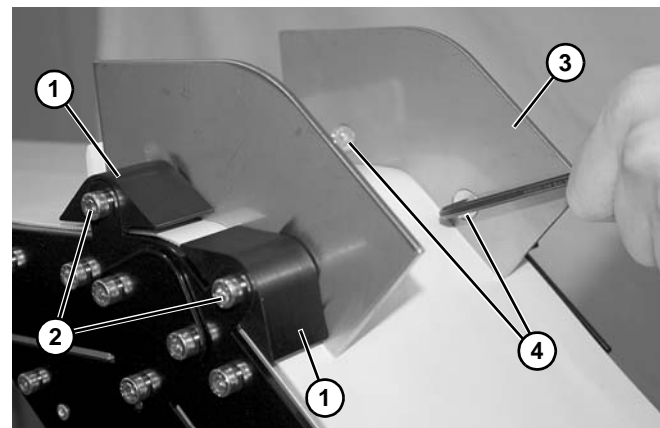

Figure 77

4. Install guard (Figure 77, item 3) on both sides of conveyor with screws (Figure 77, item 4).

Preventive Maintenance and Adjustment

5. If equipped with a lower knuckle, install roller bearing assembly (**Figure 78, item 1**) into knuckle plate (**Figure 78, item 2**) with screws (**Figure 78, item 3**) on both sides of conveyor.

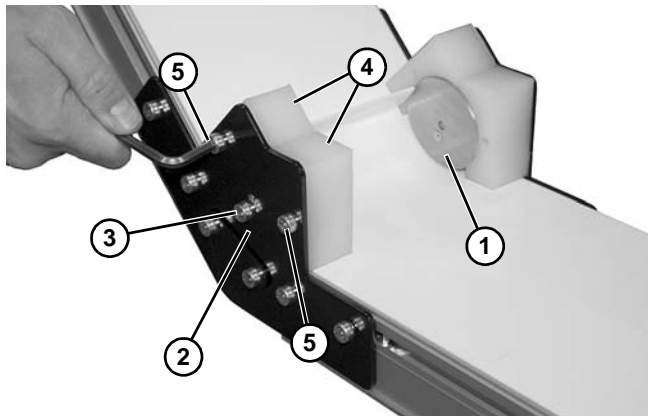

Figure 78

6. Install guards (**Figure 78, item 4**) with screws (**Figure 78, item 5**) on both sides of conveyor.
7. Tension belt. Refer to “Conveyor Belt Tensioning” on page 42.
8. If equipped, install return rollers and guiding.

Flat Belt Conveyors

1. Install idler pulley:
 - a. For 2" (44 mm) through 4" (95 mm) wide conveyors, install pulley (**Figure 79, item 1**) and pulley shaft (**Figure 79, item 2**). Install washer (**Figure 79, item 3**) and E-ring clip (**Figure 79, item 4**) on one side.

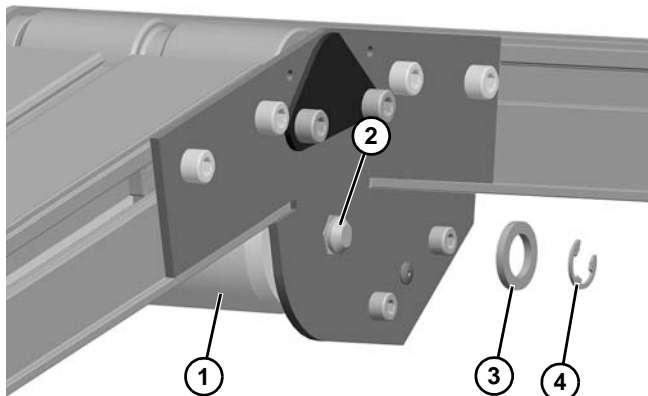

Figure 79

- b. For 5" (127 mm) or wider conveyor, push spring-loaded shaft ends (**Figure 80, item 1**) inward. Install roller (**Figure 80, item 2**).

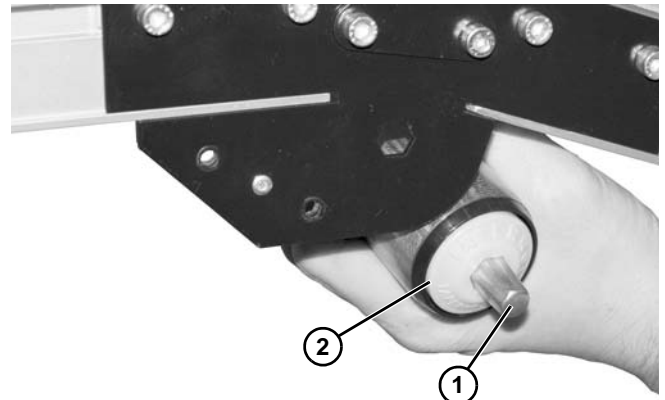

Figure 80

2. Position guard (**Figure 81, item 1**) between knuckle plates.

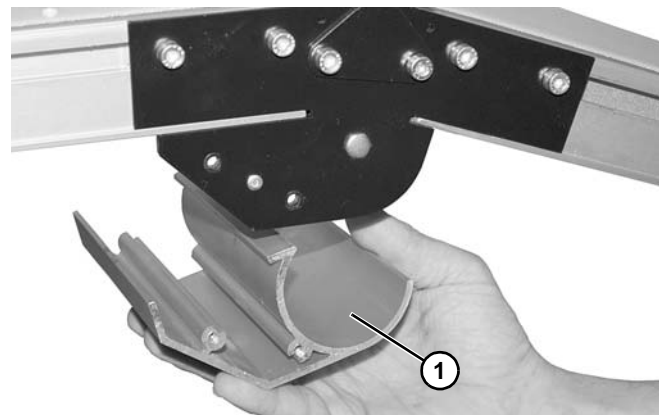

Figure 81

3. Install screws (**Figure 82, item 1**) on both sides of conveyor.

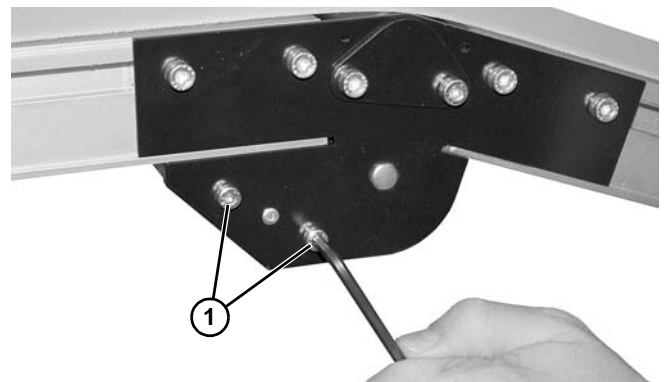



Figure 82

4. Tension belt. Refer to “Conveyor Belt Tensioning” on page 42.
5. If equipped, install return rollers and guiding.

Preventive Maintenance and Adjustment

Conveyor Belt Tensioning

⚠ WARNING

Exposed moving parts can cause severe injury. LOCK OUT POWER before removing guards or performing maintenance.

Conveyors with 1.25" (32 mm) Diameter Pulleys

1. On tension end of the conveyor, identified with a  label (**Figure 83, item 1**), adjust head plate assembly (**Figure 83, item 2**):
 - a. If equipped with dust covers (**Figure 83, item 3**), remove screw (**Figure 83, item 4**) and dust cover on both sides of conveyor. Reinstall screw (**Figure 83, item 4**).
 - b. On both sides of conveyor, loosen fastening screws (**Figure 83, item 5**) and rotate pinion gear (**Figure 83, item 6**) to adjust head plate assembly.

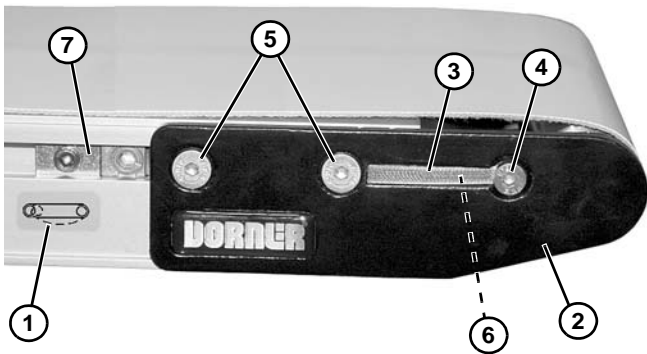

Figure 83

2. Adjust head plate assembly so end of conveyor frame aligns with or between the head plate tensioning marks (**Figure 84, item 1 & 2**). Replace belt if proper tensioning can not be obtained while aligning the end of the conveyor frame with or between the tensioning marks. See NOTE.

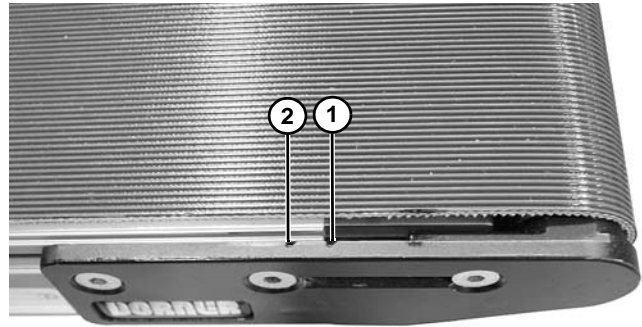

Figure 84

NOTE

On pinion gear, do not exceed a torque of 25 in-lb (2.8 Nm) for 2 – 12" (44 – 305 mm) wide conveyors and 50 in-lb (4.5 Nm) for an 18 – 24" (457 – 610 mm) wide conveyor. Over tensioning the conveyor belt could cause excessive pulley bearing load and early failure.

3. After adjusting proper tensioning, tighten fastening screws (**Figure 83, item 5**) on both sides of conveyor to 60 in-lb (7 Nm).
4. If equipped, install dust covers (**Figure 83, item 3**).
5. If equipped with cam tracking assemblies (**Figure 83, item 7**), position against head plates and adjust belt tracking. Refer to "Conveyor Belt Tracking" on page 44.

Preventive Maintenance and Adjustment

Center Drive Conveyors

The conveyor is equipped with an automatic tensioning cylinder. No tensioning adjustment is required.

For a new belt, the tension plate (**Figure 85, item 1**) will be in position indicated below left. When the tension plate extends to position indicated below right, the conveyor belt must be replaced.

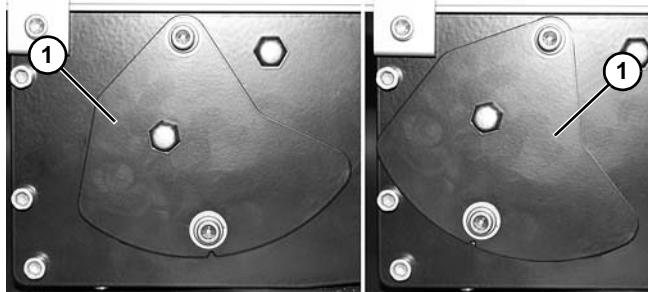

Figure 85

2. Adjust head plate assembly so end of conveyor frame aligns with or between the head plate tensioning marks (**Figure 87, item 1 & 2**). Replace belt if proper tensioning can not be obtained while aligning the end of the conveyor frame with or between the tensioning marks. See NOTE.

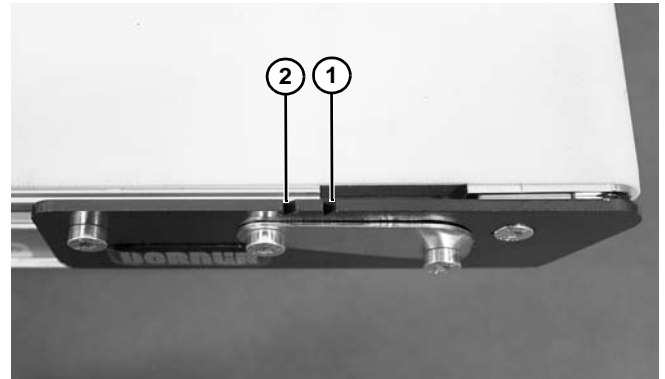



Figure 87

Conveyors with Nose Bar Idlers

1. On tension end of the conveyor, identified with a  label (**Figure 86, item 1**), adjust head plate assembly (**Figure 86, item 2**):
 - a. On both sides of conveyor, loosen fastening screws (**Figure 86, item 3**).
 - b. If equipped with dust covers (**Figure 86, item 4**), loosen screw (**Figure 86, item 5**) and remove dust cover on both sides of conveyor. Tighten screw (**Figure 86, item 5**).
 - c. Rotate pinion gear (**Figure 86, item 6**) to adjust head plate assembly.

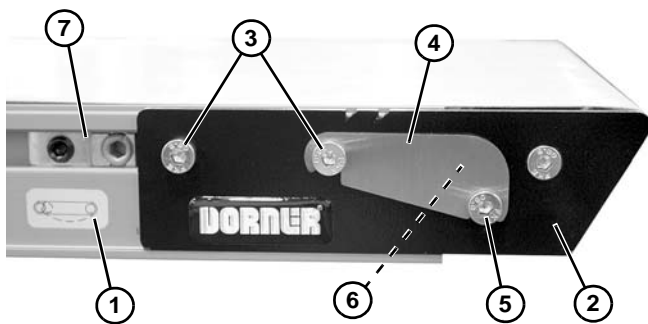

Figure 86

3. After adjusting proper tensioning, tighten fastening screws (**Figure 86, item 3**) on both sides of conveyor to 60 in-lb (7 Nm).
4. If equipped, install dust covers (**Figure 86, item 4**).
5. If equipped with cam tracking assemblies (**Figure 86, item 7**) position against head plates and adjust belt tracking. Refer to “Conveyor Belt Tracking”, next section.

NOTE

On pinion gear, do not exceed a torque of 25 in-lb (2.8 Nm) for 2 – 12" (44 – 305 mm) wide conveyors and 50 in-lb (4.5 Nm) for an 18 – 24" (457 – 610 mm) wide conveyor. Over tensioning the conveyor belt could cause excessive pulley bearing load and early failure.

Preventive Maintenance and Adjustment

Conveyor Belt Tracking

V-Guided Belts

V-guided belts do not require tracking adjustment.

Non V-Guided Belts

Non V-guided belt conveyors are equipped with belt tracking cam assemblies (**Figure 88, item 1**) for belt tracking adjustment.

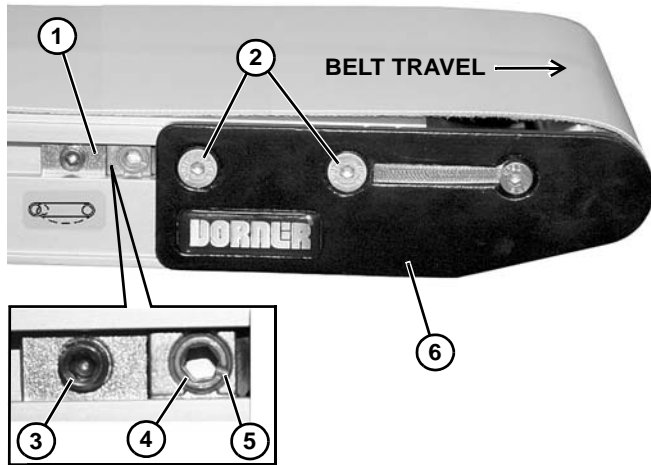

Figure 88

When adjusting belt tracking, always adjust the discharge end of the conveyor first. To adjust belt tracking:

1. Ensure head plate fastening screws (**Figure 88, item 2**) on both sides of conveyor are tightened.
2. On both sides of conveyor, loosen cam fastening screw (**Figure 88, item 3**). Adjust cams (**Figure 88, item 4**) until indicator slots (**Figure 88, item 5**) are horizontal and facing end of conveyor. Then slide cam assemblies against head plates (**Figure 88, item 6**) and re-tighten cam fastening screws (**Figure 88, item 3**) to 60 in-lb (7 Nm).
3. On the side toward which the belt is tracking, loosen head plate fastening screws (**Figure 88, item 2**).
4. With the conveyor running, use a 5 mm hex-key wrench to rotate the tracking cam (**Figure 88, item 4**) in small increments until the belt tracks in the center of the conveyor. Then while holding the cam in position, re-tighten the head plate fastening screws (**Figure 88, item 2**) with a 4 mm hex-key wrench to 60 in-lb (7 Nm).

Pulley Replacement

⚠ WARNING



Exposed moving parts can cause severe injury. LOCK OUT POWER before removing guards or performing maintenance.

Unless instructed otherwise, leave belt in place to remove the desired pulley. Follow the corresponding instructions below:

- A – Drive Pulley Removal
- B – iDrive Pulley Removal
- C – Idler Pulley Removal
- D – 5/16" Nosebar Bearing Removal
- E – 5/8" Nosebar Pulley Removal
- F – Center Drive Module Pulley Removal
- G – Mid Drive Module Pulley Removal
- H – Knuckle Idler Pulley Removal

A – Drive Pulley Removal

1. Remove belt tension.
2. On one side of the conveyor, remove screw (**Figure 89, item 1**) and remove dust cover (**Figure 89, item 2**), if installed.

NOTE

To prevent damage to the head plates, be sure to remove them slowly because they are not attached to pulley.

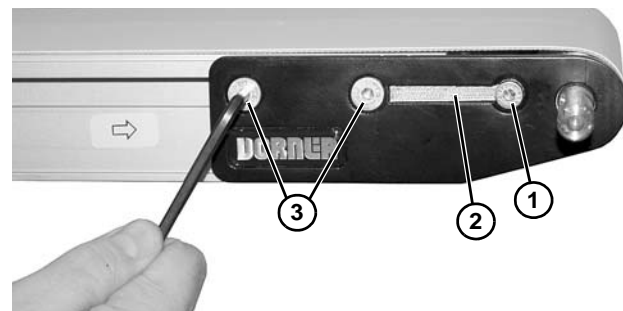

Figure 89

3. Remove two fastening screws (**Figure 89, item 3**).

Preventive Maintenance and Adjustment

⚠ WARNING



Drive shaft keyway may be sharp. **HANDLE WITH CARE.**

4. Remove the head plate (**Figure 90, item 1**) from the conveyor frame, holding spindle in place.

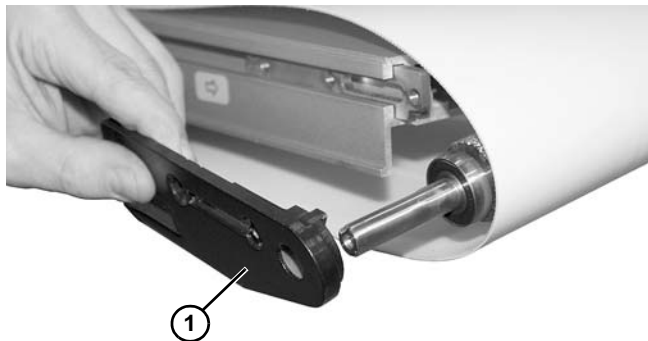

Figure 90

5. Slide the drive pulley out of the belt loop.
6. To replace the drive tail pulley, reverse the removal procedure.
7. Re-install belt on end of conveyor, then tension the belt. See “Conveyor Belt Tensioning” on page 42.
8. If installed, re-position the cam assemblies against the head plates and adjust belt tracking. See “Conveyor Belt Tracking” on page 44.

B – iDrive Pulley Removal

1. Remove belt. Refer to “Belt Removal for End Drive and iDrive Conveyors” on page 30.

NOTE

To prevent damage to the head plates and spindle, be sure to remove them slowly because they are not attached to spindle.

2. Remove drive side cover (**Figure 91, item 1**) by removing two iDrive cover screws (**Figure 91, item 2**).

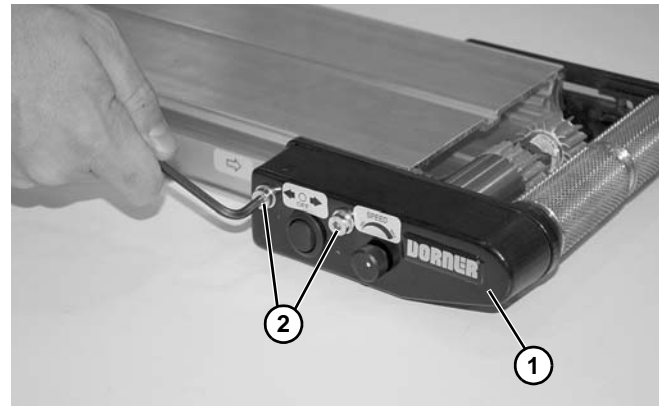

Figure 91

3. Unplug motor connector (**Figure 92, item 1**) from cover wiring connector (**Figure 92, item 2**).

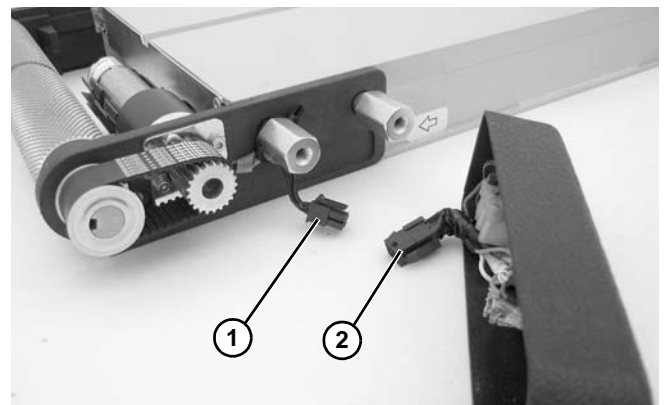

Figure 92

Preventive Maintenance and Adjustment

4. Loosen four clamp plate screws (Figure 93, item 1).

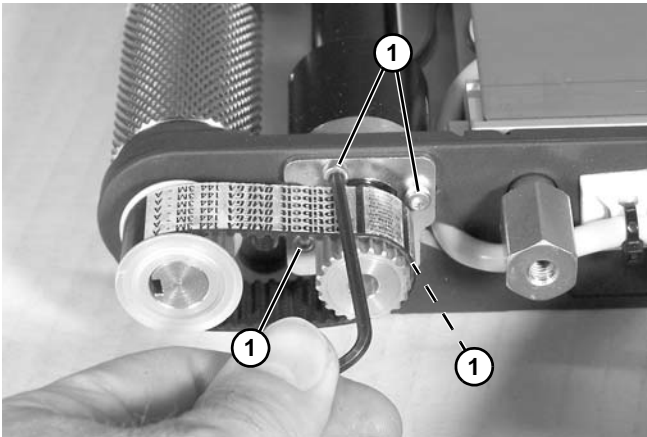

Figure 93

5. Loosen timing belt tension cam (Figure 94, item 1).

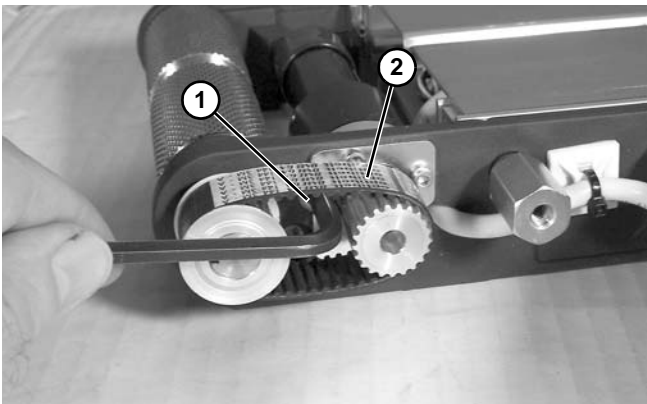

Figure 94

6. Remove timing belt (Figure 94, item 2).
7. Remove two head plate fastening screws (Figure 95, item 1) from opposite side of conveyor.

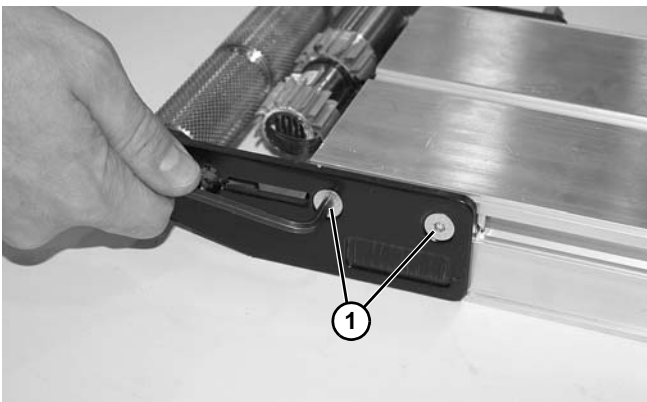

Figure 95

⚠ WARNING

Drive shaft keyway may be sharp. HANDLE WITH CARE.

8. Loosen two set screws (Figure 96, item 1) on driven pulley (Figure 96, item 2), and slide off shaft to remove.

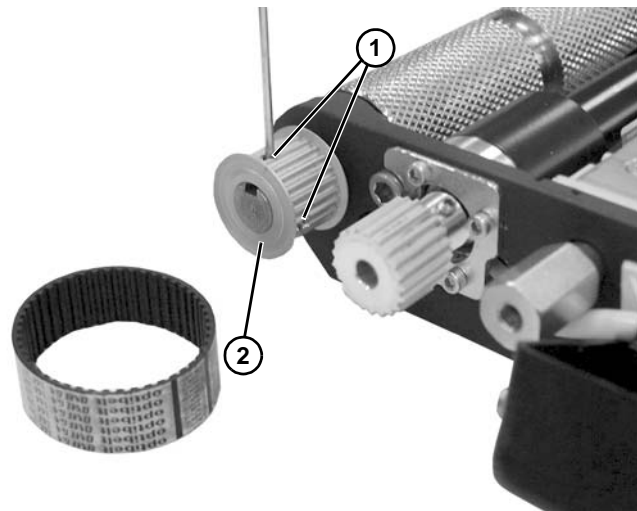

Figure 96

⚠ CAUTION
Spindle can slide out.

9. Remove head plate (Figure 97, item 1) from frame.

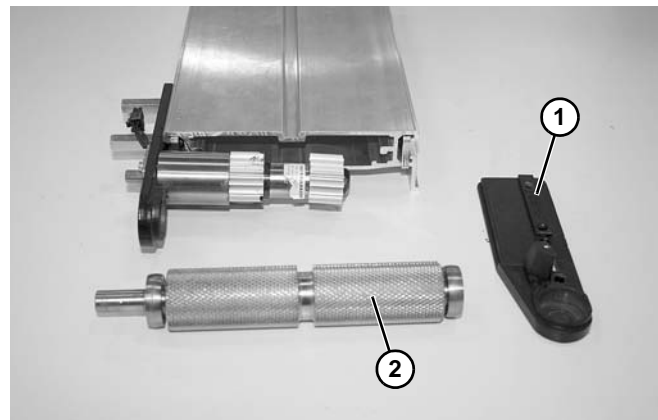

Figure 97

10. Remove and replace spindle (Figure 97, item 2).
11. Re-install in the reverse order of removal.

Preventive Maintenance and Adjustment

12. Tighten timing belt tension cam (Figure 98, item 1), making certain that pointer (Figure 98, item 2) on cam is pointing towards the motor drive spindle (Figure 98, item 3).

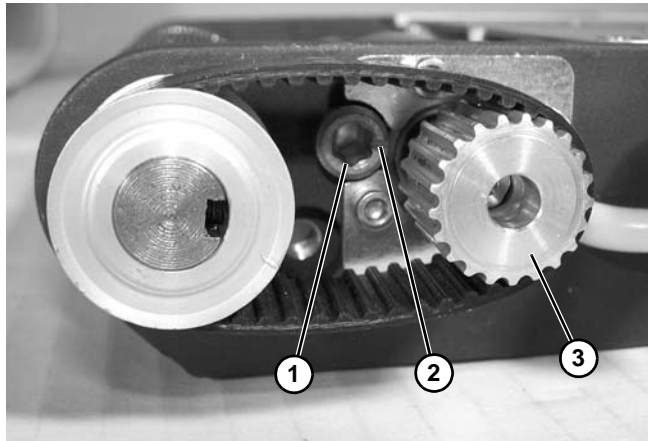

Figure 98

13. Rotate tension cam (Figure 98, item 1) to fully tension the timing belt (Figure 99, item 1). Tighten four clamp plate screws (Figure 99, item 2) to 15 in-lb (1.7 Nm) to secure position.

CAUTION

Over tightening of timing belt will result in reduced gearmotor and timing belt life.

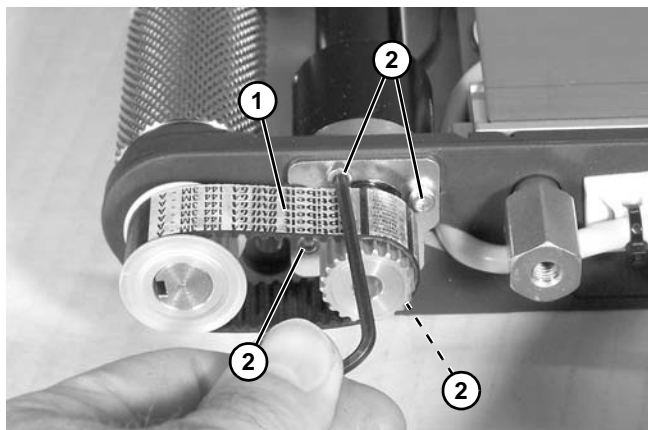

Figure 99

14. Re-install belt on end of conveyor, then tension the belt. See "Conveyor Belt Tensioning" on page 42.
15. If installed, re-position the cam assemblies against the head plates and adjust belt tracking. See "Conveyor Belt Tracking" on page 44.

C – Idler Pulley Removal

1. On one side of the conveyor, remove screw (Figure 100, item 1) and remove dust cover (Figure 100, item 2), if installed.

NOTE

To prevent damage to the head plates, be sure to remove them slowly because they are not attached to pulley.

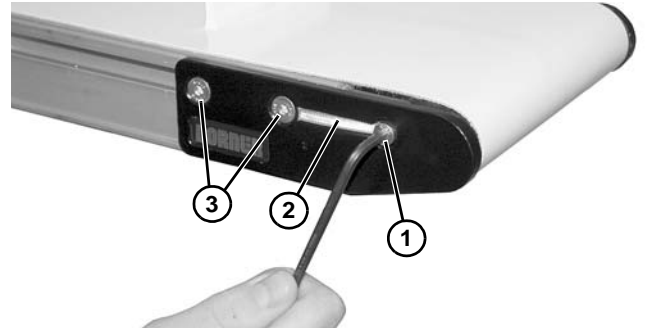

Figure 100

2. Remove two fastening screws (Figure 100, item 3).
3. Remove the head plate (Figure 101, item 1) from the conveyor frame, holding spindle in place.

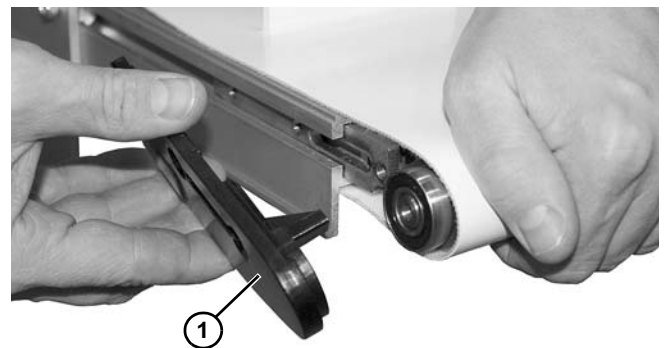

Figure 101

4. Slide spindle out of the belt loop.
5. To replace the idler tail pulley, reverse the removal procedure.
6. Re-install belt on end of conveyor, then tension the belt. See "Conveyor Belt Tensioning" on page 42.
7. If installed, re-position the cam assemblies against the head plates and adjust belt tracking. See "Conveyor Belt Tracking" on page 44.

Preventive Maintenance and Adjustment

D – 5/16" (8 mm) Tight Radius Nosebar Bearing Removal

1. On both sides of conveyor, loosen cam fastening screw (**Figure 102, item 1**) (if equipped) and slide cam assemblies toward the center of the conveyor.

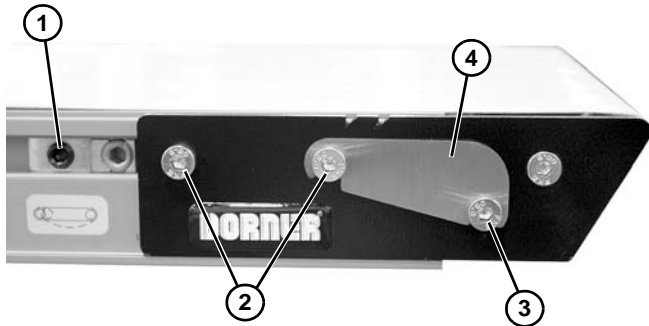

Figure 102

2. On both sides of conveyor, loosen two fastening screws (**Figure 102, item 2**) to remove belt tension. Remove belt from end of conveyor.
3. On both sides of conveyor, loosen fastening screw (**Figure 102, item 3**) and remove dust cover (**Figure 102, item 4**) (if equipped).
4. Remove nosebar tail from the conveyor and place on an open work surface. On one side of nosebar tail, remove two fastening screws (**Figure 102, item 2**).
5. Remove lower screw (**Figure 103, item 1**) and remove tail nut bar (**Figure 103, item 2**) and side plate (**Figure 103, item 3**).

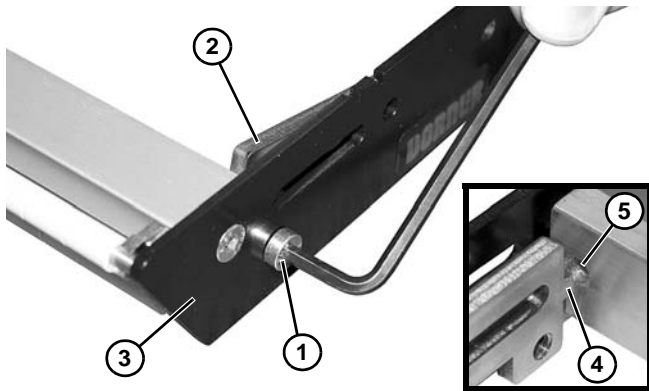

Figure 103

NOTE

During reassembly, make certain that the tail nut bar nipple (**Figure 103, item 4**) is inserted into the support bar hole (**Figure 103, item 5**).

6. Remove outer and inner end plate (**Figure 104, item 1**).

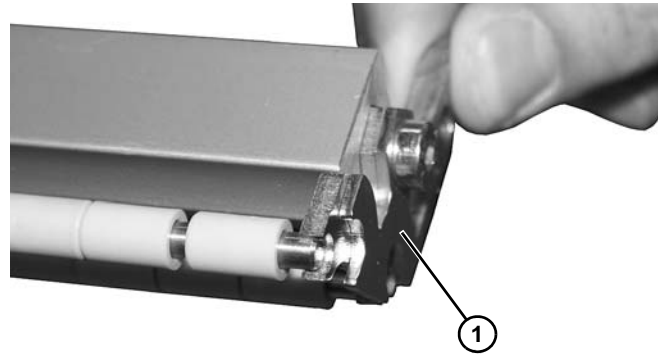

Figure 104

7. Remove and replace bearings (**Figure 105, item 1**) and rods (**Figure 105, item 2**) as necessary.

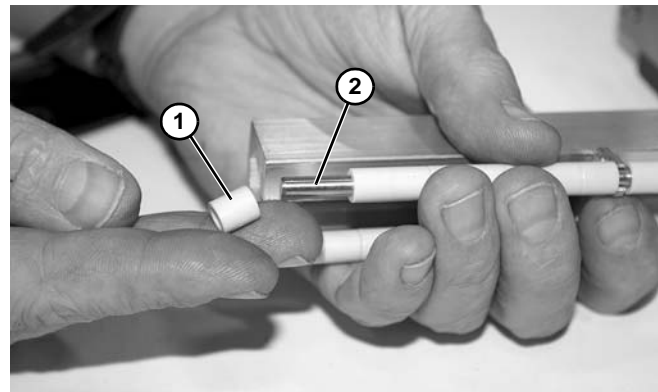

Figure 105

8. Assemble and install head plate in reverse order of removal. Use a hex-key wrench to tighten lower screw (**Figure 103, item 1**) to 30 in-lb (3.4 Nm). Leave two fastening screws (**Figure 102, item 2**) loose for belt tensioning.
9. Re-install belt on end of conveyor, then tension the belt. See "Conveyor Belt Tensioning" on page 42.
10. Re-position the cam assemblies (if equipped) against the head plates and adjust belt tracking. See "Conveyor Belt Tracking" on page 44.

Preventive Maintenance and Adjustment

E – 5/8" (16 mm) Nosebar Pulley Removal

1. On both sides of conveyor, loosen cam fastening screw (**Figure 106, item 1**) (if equipped) and slide cam assemblies toward the center of the conveyor.

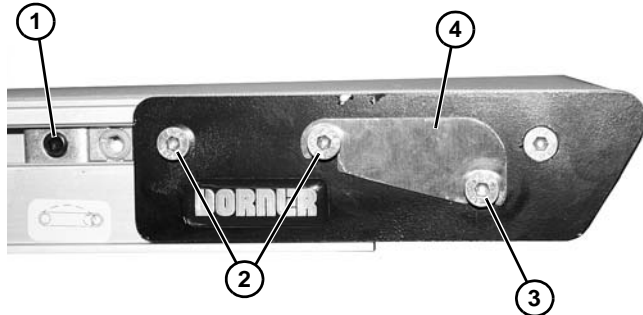

Figure 106

2. On both sides of conveyor, loosen fastening screws (**Figure 106, item 2**) to remove belt tension. Remove belt from end of conveyor.
3. On both sides of conveyor, loosen fastening screw (**Figure 106, item 3**) and remove dust cover (**Figure 106, item 4**) (if equipped).
4. Remove nosebar tail from the conveyor and place on an open work surface. On one side of nosebar tail, remove two fastening screws (**Figure 106, item 2**).
5. Remove lower screw (**Figure 107, item 1**) and remove tail nut bar (**Figure 107, item 2**) and side plate (**Figure 107, item 3**).

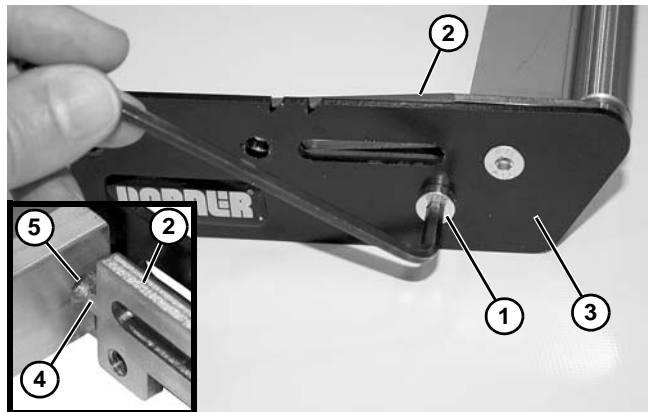

Figure 107

NOTE

During reassembly, make certain that the tail nut bar nipple (**Figure 107, item 4**) is inserted into the support bar hole (**Figure 107, item 5**).

6. Remove outer and inner end plate (**Figure 108, item 1**).

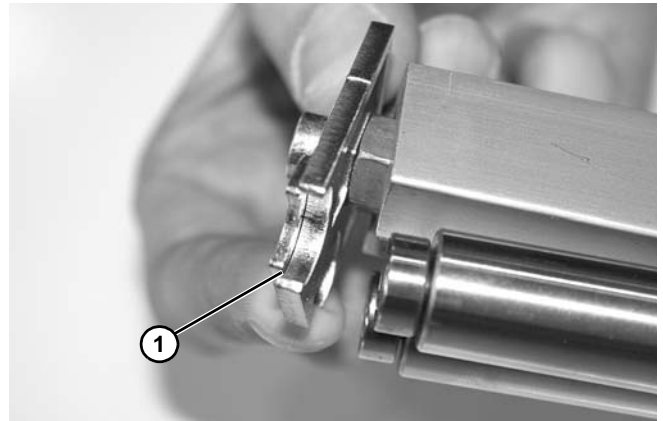

Figure 108

7. Remove spindles (**Figure 109, item 1**).

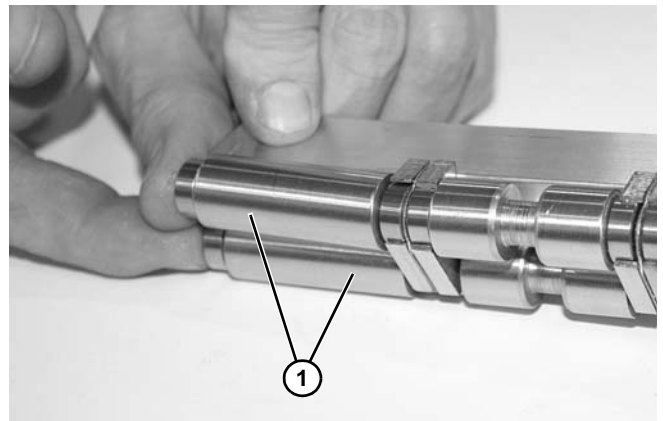

Figure 109

8. Remove bearing carrier (if installed) (**Figure 110, item 1**) and spindles (**Figure 110, item 2**).

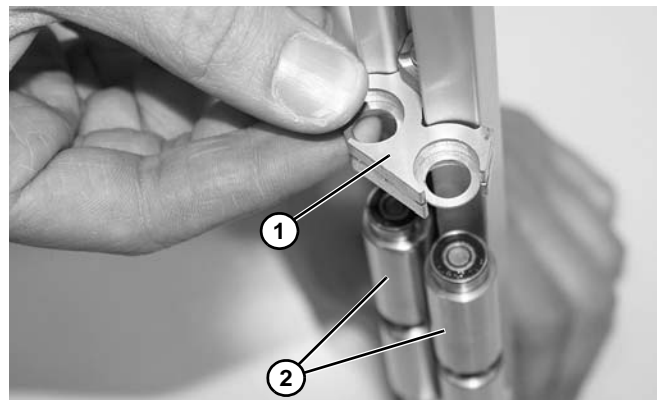

Figure 110

9. Repeat step 8 for remaining spindles.
10. Assemble and install head plate in reverse order of removal. Use a 4 mm hex-key wrench to tighten lower screw (**Figure 107, item 1**) to 30 in-lb (3.4 Nm). Leave two fastening screws (**Figure 106, item 2**) loose for belt tensioning.

Preventive Maintenance and Adjustment

11. Re-install belt on end of conveyor, then tension the belt. See “Conveyor Belt Tensioning” on page 42.
12. Re-position the cam assemblies (if equipped) against the head plates and adjust belt tracking. See “Conveyor Belt Tracking” on page 44.

F – Center Drive Module Pulley Removal

Remove the conveyor belt to access the pulley(s). Refer to “Belt Removal for Center Drive Conveyors” on page 31, steps 1 through 10.

Perform one of the following procedures to remove desired pulley:

- Drive Module Drive Pulley Removal
- Drive Module Idler Pulley Removal

Drive Module Drive Pulley Removal

1. Remove the gearmotor drive package. Refer to “Gearmotor Mounting Package Removal” on page 32.
2. Remove the drive module. Refer to “Drive Module Removal” on page 33.
3. Remove the drive pulley. Refer to “Belt Removal from Drive Module” on page 34, steps 1 and 2.
4. To replace the pulley, reverse the removal procedure.
5. Re-install belt on end of conveyor, then tension the belt. See “Conveyor Belt Tensioning” on page 42.
6. If installed, re-position the cam assemblies against the head plates and adjust belt tracking. See “Conveyor Belt Tracking” on page 44.

Drive Module Idler Pulley Removal

1. Remove the gearmotor drive package. Refer to “Gearmotor Mounting Package Removal” on page 32.
2. Remove the drive module. Refer to “Drive Module Removal” on page 33.
3. Remove the grooved idler pulley. Refer to “Belt Removal from Drive Module” on page 34, step 3.
4. Remove smooth idler pulleys:
 - a. For 2" (44 mm), 3" (70 mm) or 4" (95 mm) wide conveyor, remove E-ring clips and washers (**Figure 111, item 1**). Remove pulley shafts (**Figure 111, item 2**) and pulleys (**Figure 111, item 3**).

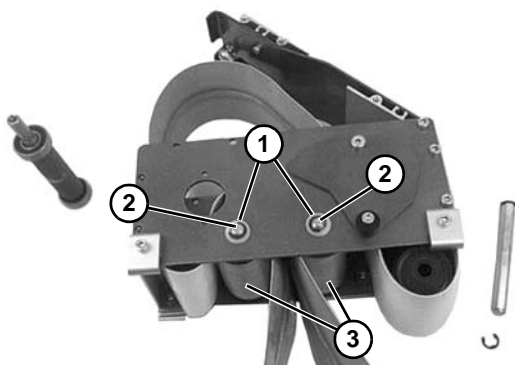

Figure 111

- b. For 5" (127 mm) or wider conveyor, depress both sides of each spring-loaded shaft (**Figure 112, item 1**). Remove pulleys (**Figure 112, item 2**).

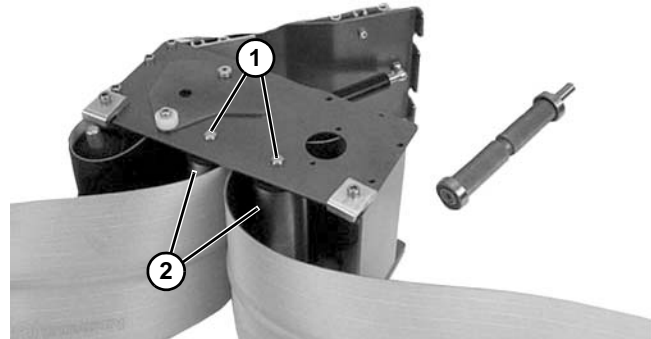



Figure 112

5. To replace the pulley, reverse the removal procedure.
6. Re-install belt on end of conveyor, then tension the belt. See “Conveyor Belt Tensioning” on page 42.
7. Re-position the cam assemblies (if equipped) against the head plates and adjust belt tracking. See “Conveyor Belt Tracking” on page 44.

G – Mid Drive Module Pulley Removal

1. On tension end of the conveyor, identified with  a label (**Figure 113, item 1**), push in head plate assembly (**Figure 113, item 2**):
 - a. On both sides of conveyor, loosen and move cam tracking assemblies (**Figure 113, item 3**) (if equipped) away from head plates.
 - b. Loosen fastening screws (**Figure 113, item 4**) and push head plate assembly inward.

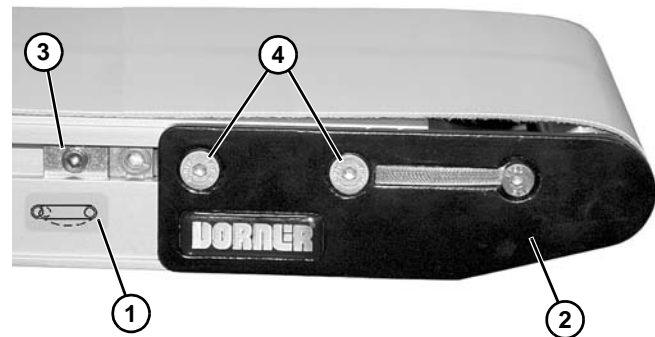

Figure 113

2. Remove drive package. See your appropriate Drive Package manual for removal procedure.

Preventive Maintenance and Adjustment

- Loosen one socket head screw (**Figure 114, item 1**) from each side of mounting block (**Figure 114, item 2**).

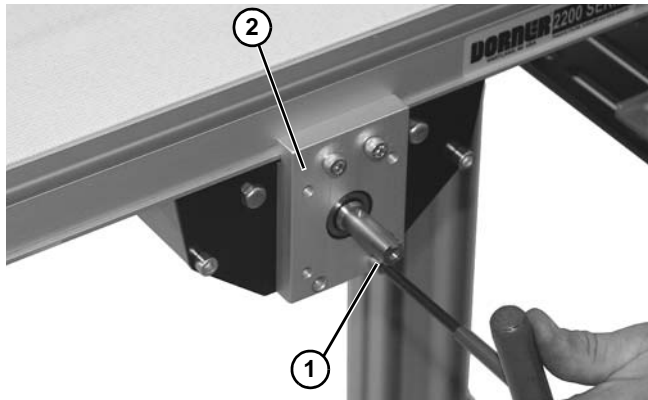

Figure 114

- Lower and remove mid drive module (**Figure 115, item 1**) from belt (**Figure 115, item 2**).

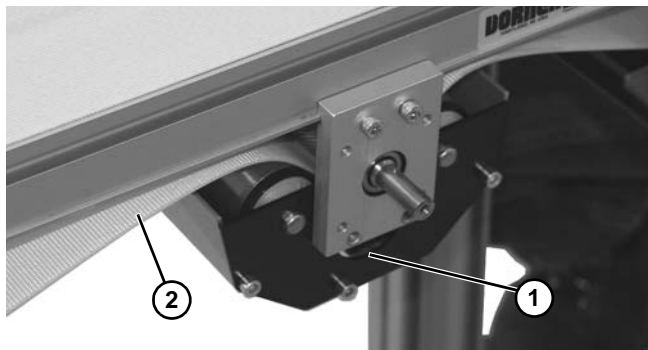

Figure 115

- Loosen two socket head screws (**Figure 116, item 1**) from each side of mounting block (**Figure 116, item 2**).

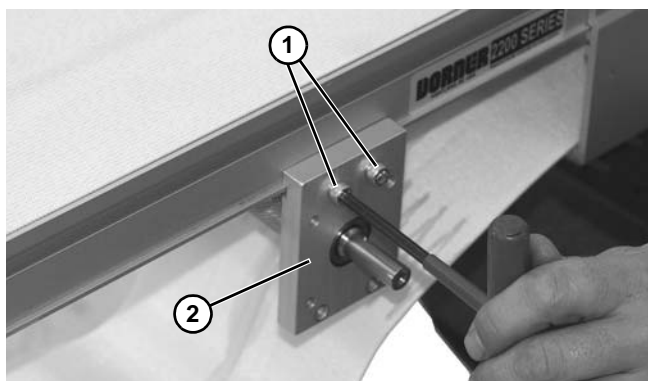

Figure 116

- Separate mounting blocks (**Figure 117, item 1**) from spindle (**Figure 117, item 2**).

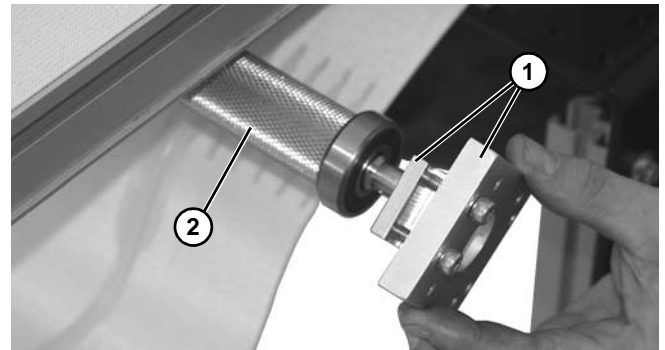

Figure 117

- Replace spindle.
- Install components, reverse order of removal.
- Be certain to use a square (**Figure 118, item 1**) across mounting blocks (**Figure 118, item 2**), so blocks are aligned to one another, before tightening hardware.

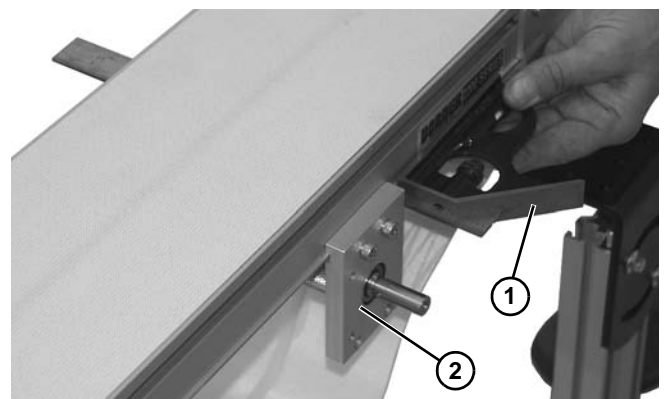

Figure 118

- Tighten socket head screws (**Figure 114, item 1**) and (**Figure 116, item 1**) to 60 in-lb (7 Nm).
- Tension conveyor belt. See “Conveyor Belt Tensioning” on page 42.

Preventive Maintenance and Adjustment

H – Knuckle Idler Pulley Removal

1. Remove belt. See “Belt Removal for LPZ Conveyors” on page 35.
2. Temporarily support the knuckle idler pulley.

NOTE

The procedure shown is for a knuckle on a Flat Belt conveyor. The removal procedure for other knuckle types is the same.

3. Remove two screws (Figure 119, item 1) and remove bearing cover (Figure 119, item 2) on both sides of knuckle.

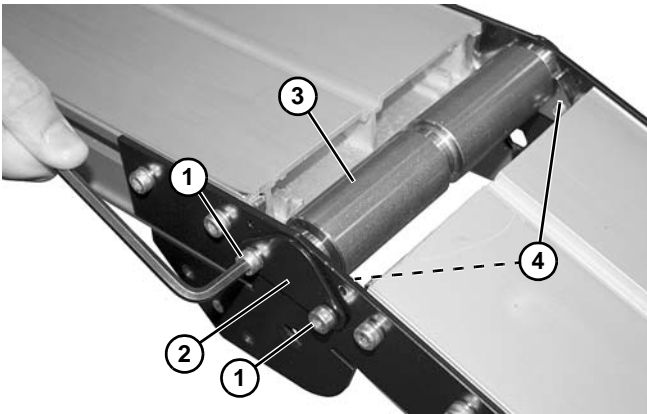

Figure 119

4. Slide idler pulley (Figure 119, item 3) to one side of the conveyor, remove bearing housings (Figure 119, item 4), and then remove idler pulley from knuckle plates.

Bearing Removal and Replacement

Removal

IMPORTANT

Do not use any removed bearings. Replace them.

1. Place bearing removal tool part #456063 (Figure 120, item 1) below bearing (Figure 120, item 2) with lip (Figure 120, item 3) located in gap (Figure 120, item 4) between bearing and spindle hub (Figure 120, item 5) as shown.

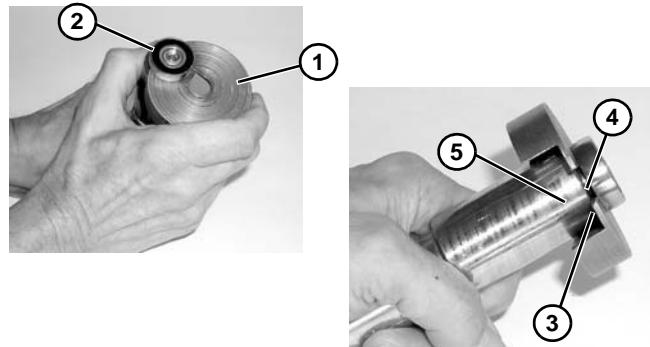

Figure 120

2. Using puller part #807-1716 (Figure 121, item 1), remove and discard bearing.

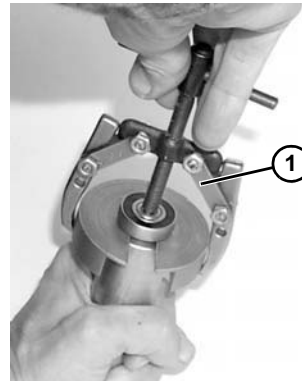

Figure 121

Preventive Maintenance and Adjustment

Replacement

1. Inspect the head plates bearing seating surface (**Figure 122, item 1**). If they are worn or damaged, replace. See “Service Parts” on page 60.

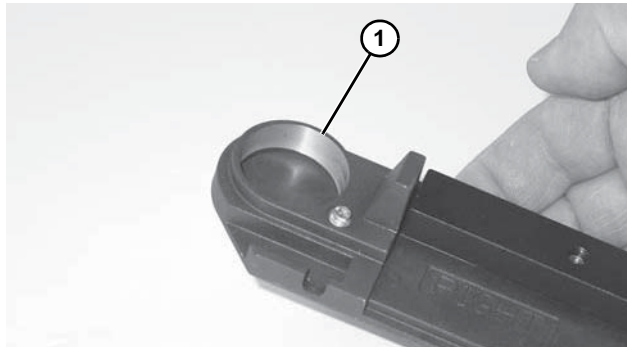

Figure 122

2. Inspect spindle (**Figure 123, item 1**). Replace if worn.
3. Slide bearing (**Figure 123, item 2**) onto spindle.

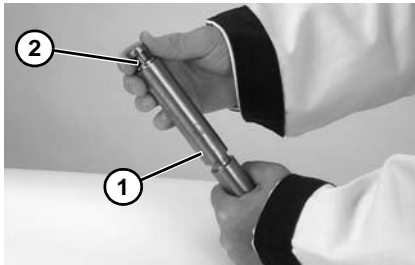

Figure 123

4. Using an arbor press or similar device, press bearing onto pulley shaft (**Figure 124**).

⚠ WARNING

Be certain that bearing and shaft is set onto press completely flush with press cylinder plate. If not, damage to bearing or shaft could result.

Keep hands and fingers away from press and components during procedure.



Figure 124

5. Repeat steps 1 through 4 for each bearing.

iDrive Motor Replacement

1. Remove belt. Refer to “Belt Removal for End Drive and iDrive Conveyors” on page 30.
2. Remove inframe drive side cover (**Figure 125, item 1**) by removing two head plate fastening screws (**Figure 125, item 2**).

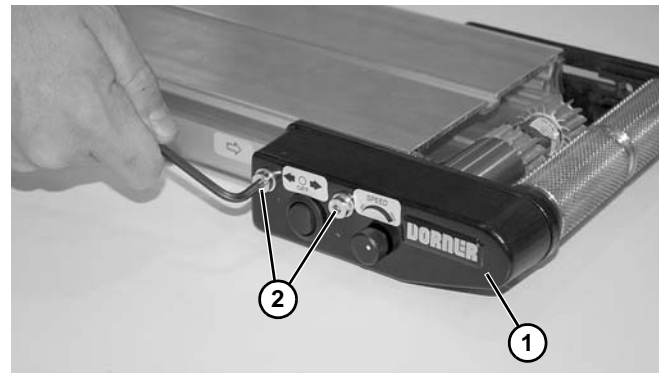

Figure 125

3. Unplug motor connector (**Figure 126, item 1**) from cover wiring connector (**Figure 126, item 2**), and cut cable tie (**Figure 126, item 3**) from conveyor.

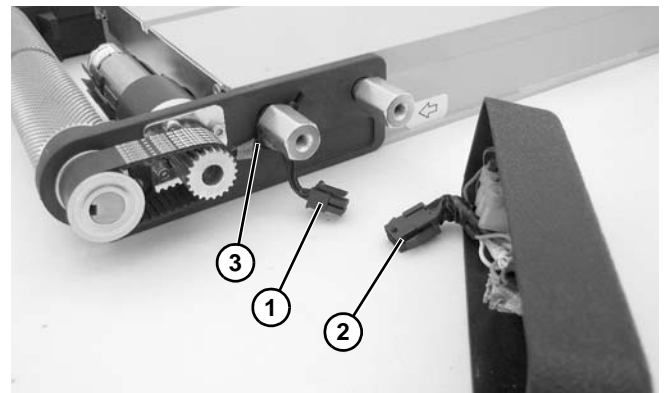

Figure 126

4. Loosen four clamp plate screws (**Figure 127, item 1**).

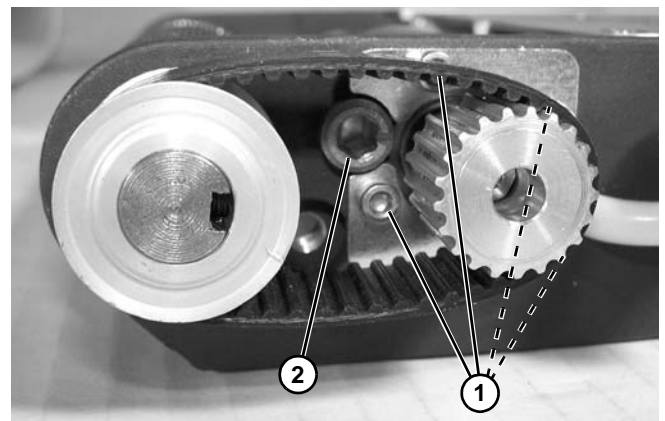

Figure 127

5. Loosen timing belt tension cam (**Figure 127, item 2**).

Preventive Maintenance and Adjustment

- Loosen two set screws (Figure 128, item 1) on drive pulley (Figure 128, item 2). Slide drive pulley outward off of gearmotor shaft and remove timing belt (Figure 128, item 3).

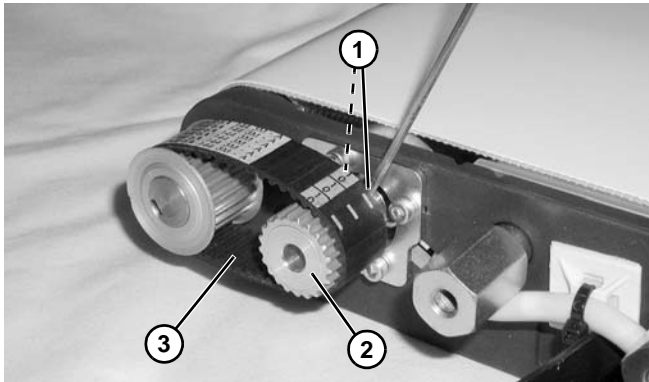

Figure 128

- Remove four clamp plate screws (Figure 129, item 1) and clamp plate (Figure 129, item 2).

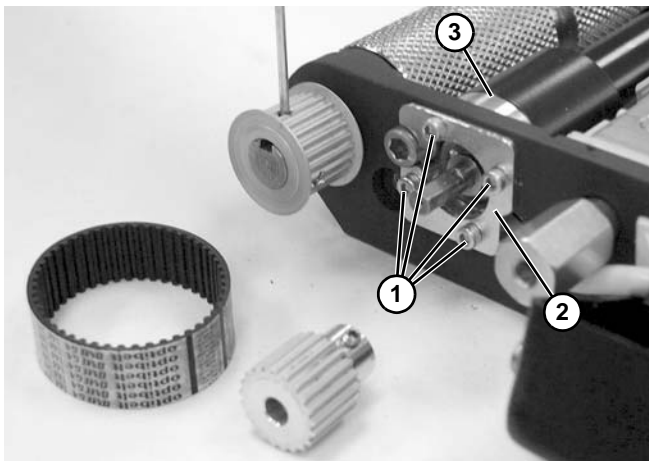

Figure 129

- Remove and replace motor (Figure 129, item 3).

NOTE

When reassembling, make sure the pointer on the timing belt tension cam is pointing towards the motor.

- Reinstall in reverse order of removal. (Refer to steps 12 and 13 of “B – iDrive Pulley Removal” on page 45 for timing belt tensioning.)

Knuckle Return Roller Replacement

Cleated Belt Conveyor

- Remove belt tension.
- If equipped with a lower knuckle, remove screws (Figure 130, item 1) and remove guards (Figure 130, item 2) on both sides of knuckle.

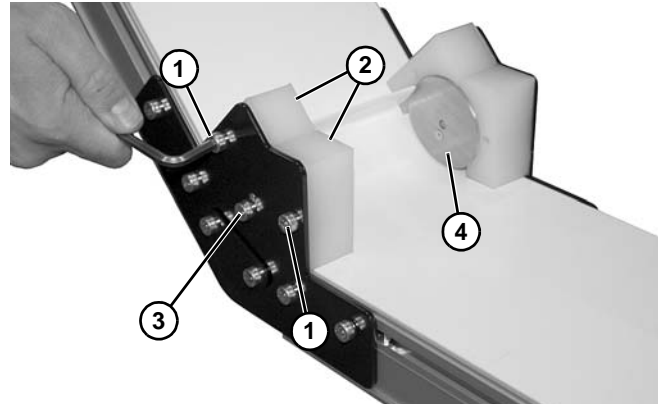

Figure 130

- Remove screws (Figure 130, item 3) and remove roller bearing assembly (Figure 130, item 4) on both sides of knuckle.
- If equipped with an upper knuckle, remove screws (Figure 131, item 1) and remove guard (Figure 131, item 2) on both sides of knuckle.

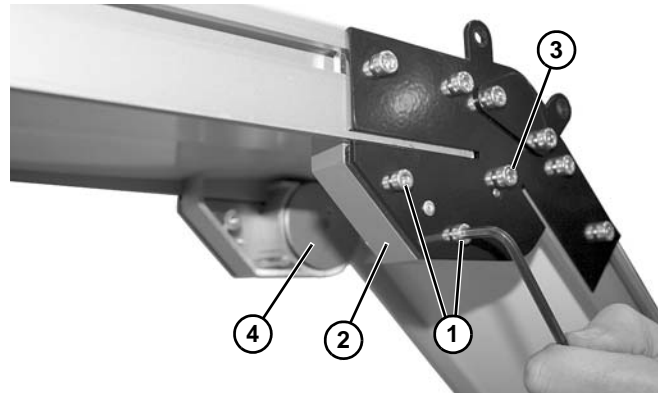

Figure 131

- Remove screw (Figure 131, item 3) and remove roller bearing assembly (Figure 131, item 4) on both sides of knuckle.

Preventive Maintenance and Adjustment

Flat Belt Conveyor

1. Remove screws (Figure 132, item 1) on both sides of conveyor.

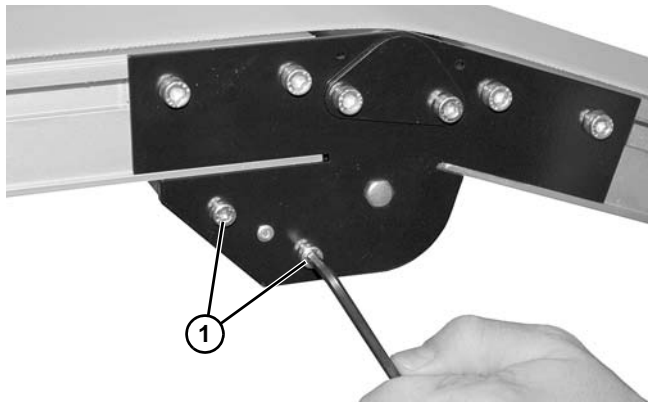

Figure 132

2. Remove guard (Figure 133, item 1).

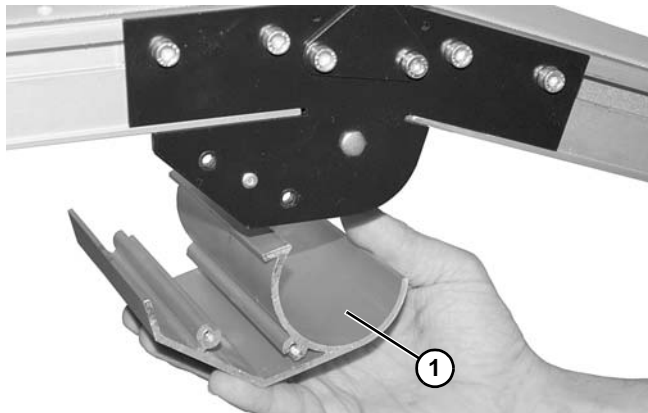

Figure 133

3. Remove idler pulley:

- a. For 2" (44 mm) through 4" (95 mm) wide conveyors, remove E-ring clip (Figure 134, item 1) and washer (Figure 134, item 2) from one side. Remove pulley shaft (Figure 134, item 3) and pulley (Figure 134, item 4).

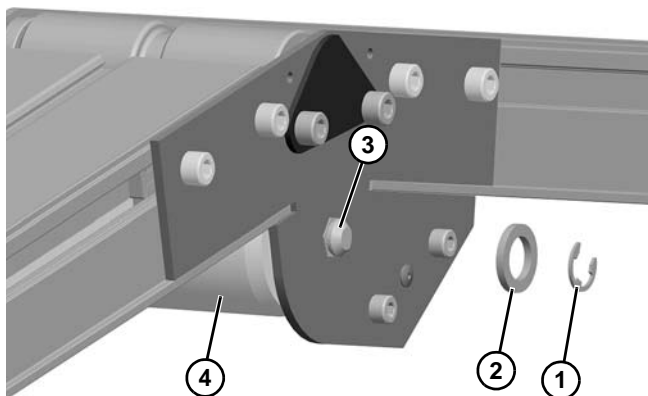

Figure 134

- b. For 5" (127 mm) or wider conveyor, push spring-loaded shaft ends (Figure 135, item 1) inward. Remove roller (Figure 135, item 2).

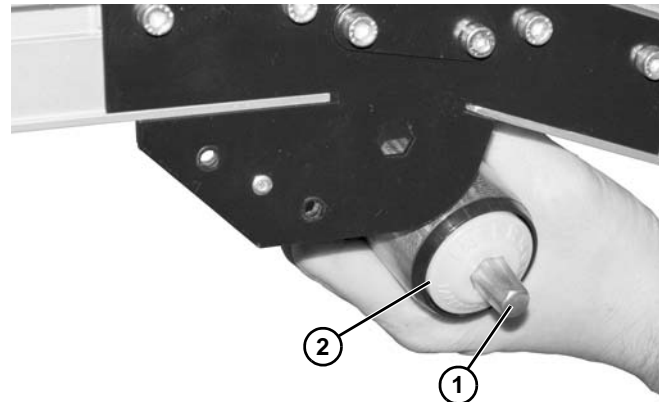

Figure 135

Preventive Maintenance and Adjustment

Tail Plate Shaft Knockout Removal

1. Determine which tail plate(s) require the hole knockout slug to be removed for the drive shaft.
 - Position A or B = 205370-LH
 - Position C or D = 205370-RH
2. Set tail plate (**Figure 136, item 1**) flat side down over washer (**Figure 136, item 2**) or hole in workbench that has a minimum diameter of 5/8".

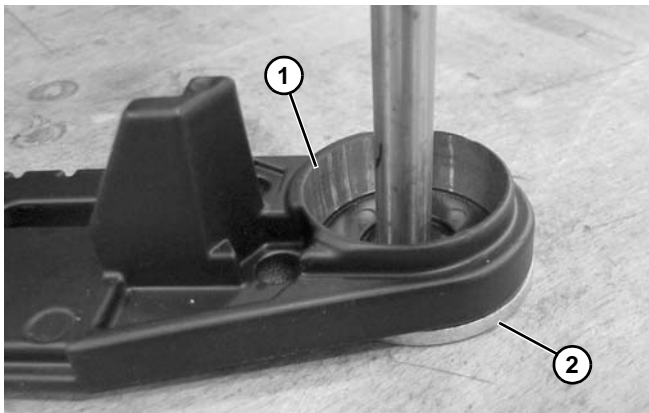

Figure 136

3. Use a hammer and punch (1/4" - 1/2" dia) (**Figure 137, item 1**) or long bolt to knock out slug (**Figure 138, item 1**) for shaft backing up tail plate with washer.

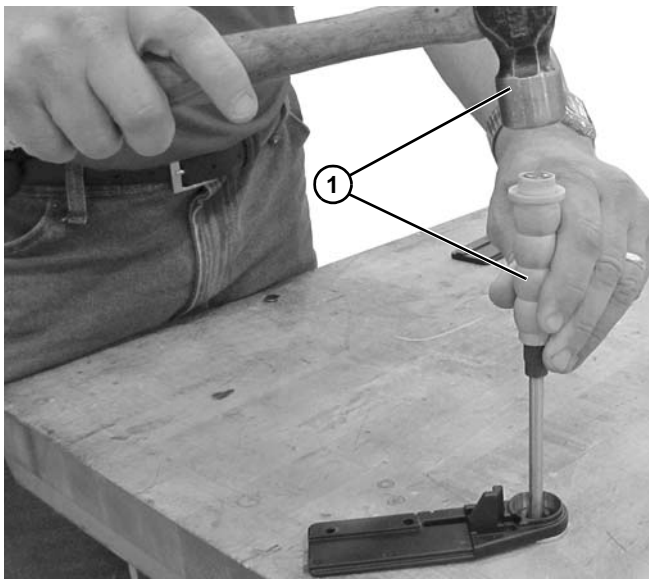

Figure 137

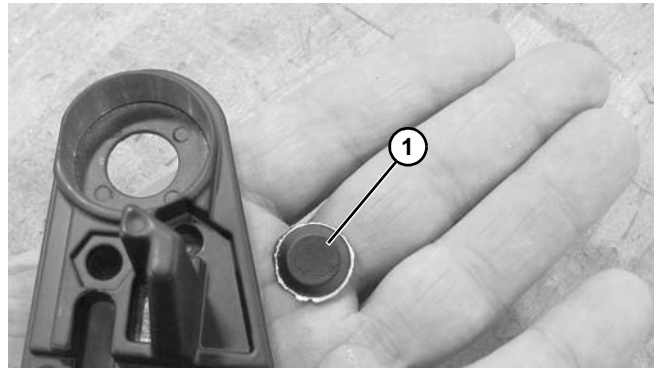

Figure 138

4. Repeat the same operation to knockout (**Figure 140, item 1**) for alignment screw hole using 1/8" - 3/16" punch (**Figure 139, item 1**) or M5 - M6 bolt.

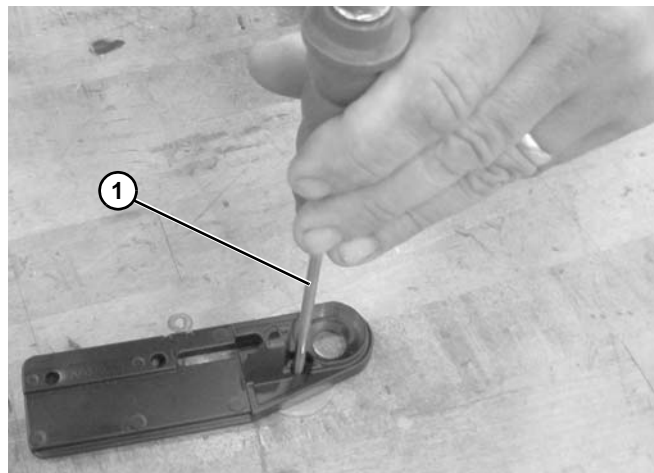

Figure 139

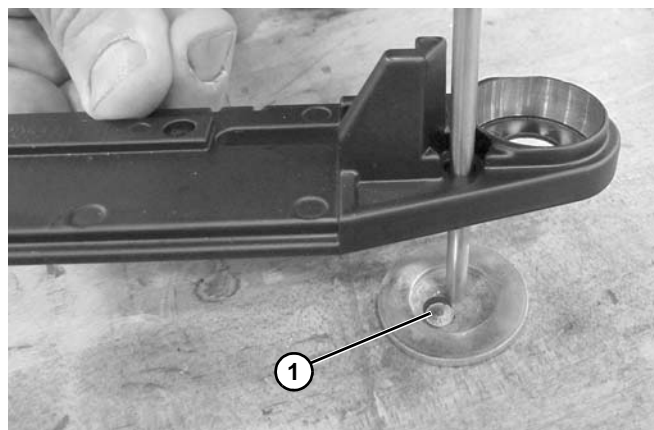

Figure 140

Preventive Maintenance and Adjustment

Pinion Replacement

1. Remove conveyor belt. See “Conveyor Belt Replacement” section on page 29.
2. Remove idler tail (**Figure 141, item 1**) by sliding off of the conveyor (**Figure 141, item 2**).

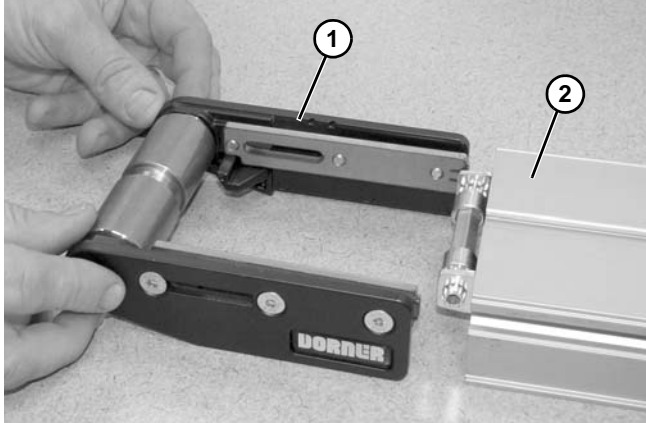

Figure 141

3. Pry pinion assembly (**Figure 142, item 1**) from conveyor frame by alternating sides.

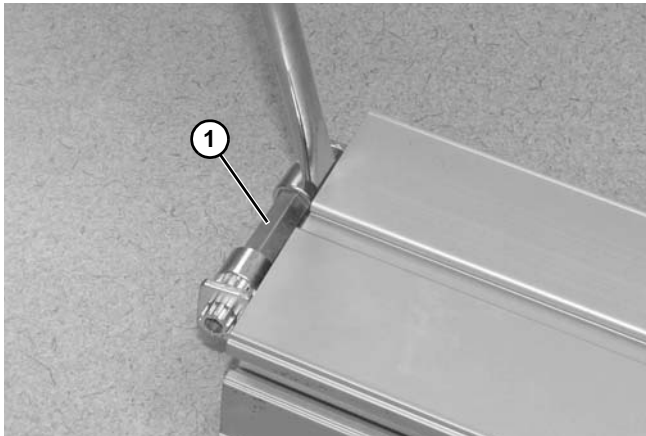

Figure 142

4. Replace worn components.

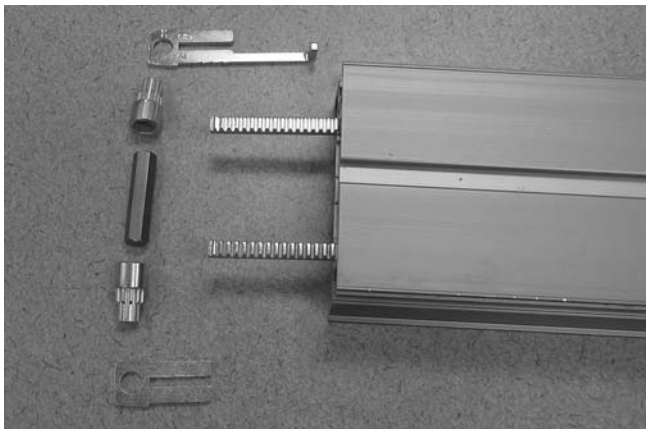

Figure 143

5. To reassemble, make sure that the lines (**Figure 144, item 1**) on the pinion end gears (**Figure 144, item 2**) are aligned.

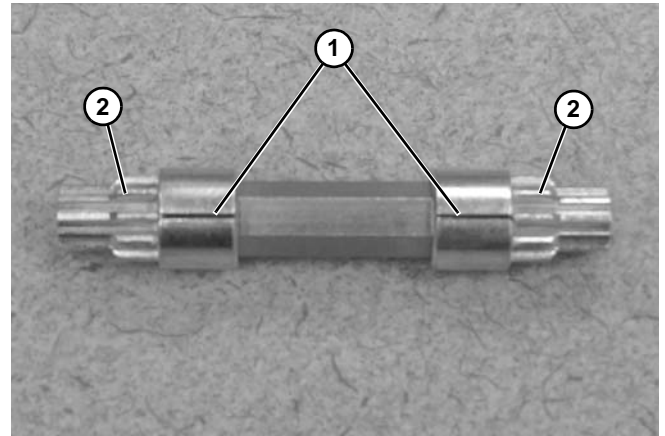

Figure 144

6. Slide on retaining plates (**Figure 145, item 1**).

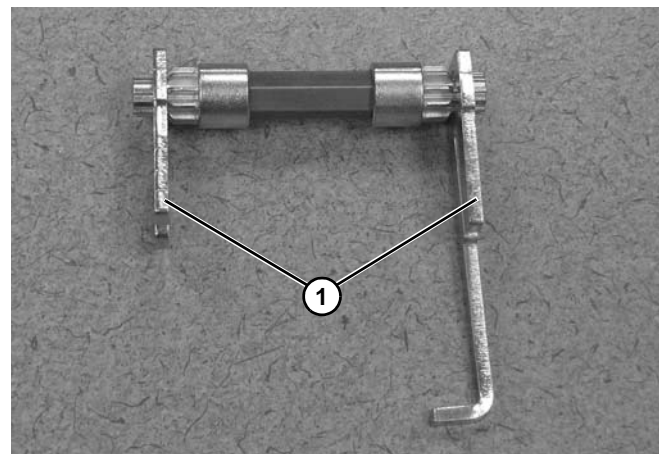

Figure 145

7. Insert pinion assembly (**Figure 146, item 1**) into conveyor frame.

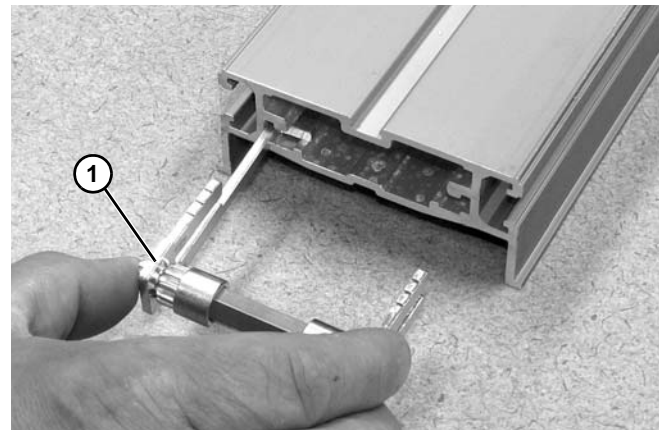

Figure 146

Preventive Maintenance and Adjustment

8. Tap alternating retaining plates (**Figure 147, item 1**) and (**Figure 148, item 1**) with a hammer until fully assembled onto conveyor frame.

⚠ CAUTION

Do not hit pinion gear with hammer. It may cause damage to the pinion teeth.

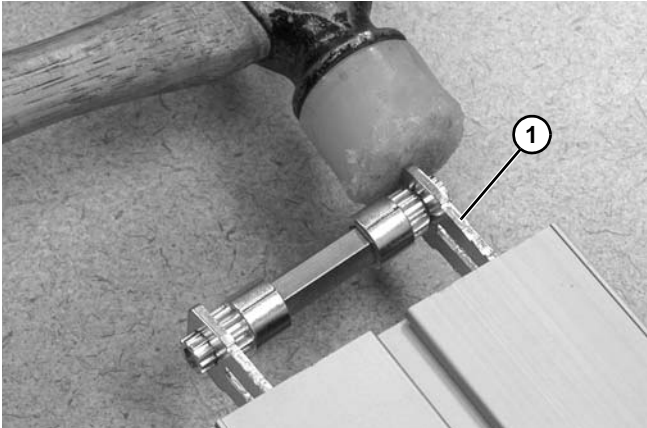

Figure 147

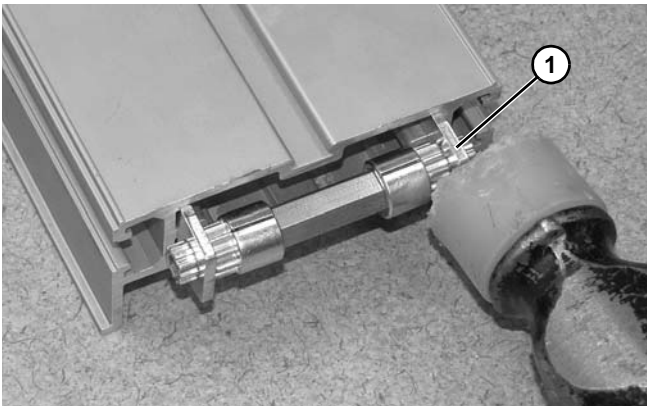

Figure 148

9. Insert both gear racks (**Figure 149, item 1**) into conveyor frame.

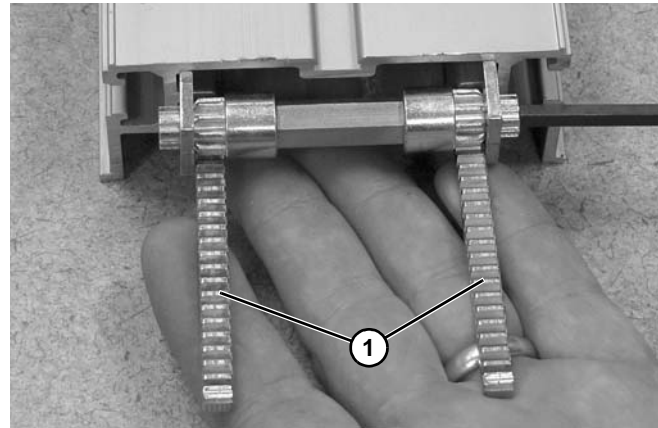

Figure 149

NOTE

*Make sure the bent end (**Figure 150, item 1**) of the gear rack is NOT assembled into the conveyor frame.*

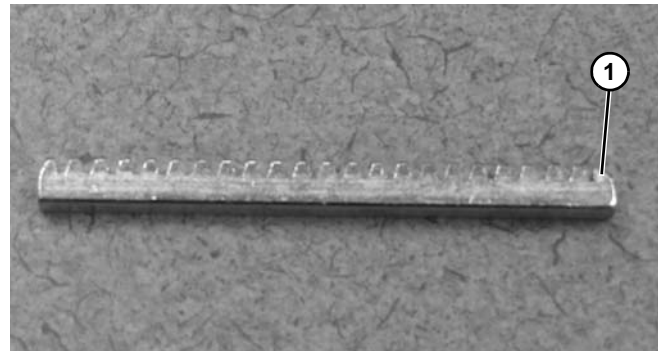

Figure 150

Preventive Maintenance and Adjustment

10. Rotate pinion (**Figure 151, item 1**) with hex wrench until gear racks (**Figure 151, item 2**) are fully collapsed.

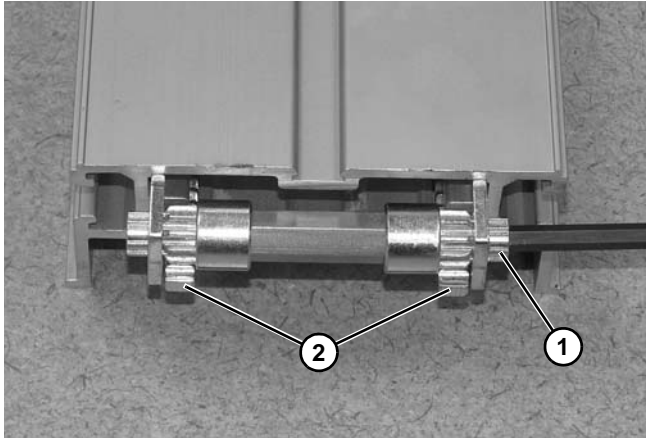

Figure 151

NOTE

The gear racks must be aligned with each other, as shown above. Example of misaligned gear racks shown below.

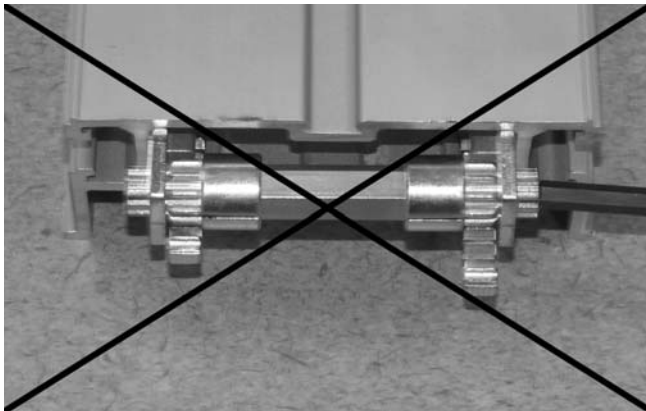

Figure 152

11. Reinstall idler tail by sliding tail assembly (**Figure 153, item 1**) fully back onto conveyor frame.

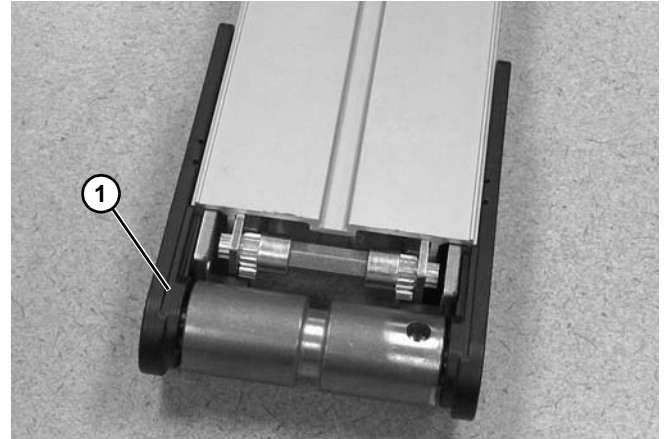



Figure 153

12. Reinstall belt on end of conveyor, then tension the belt. See “Conveyor Belt Tensioning” on page 42.

Service Parts

NOTE

For replacement parts other than those shown in this section, contact an authorized Dorner Service Center or the factory. Key Service Parts and Kits are identified by the Performance Parts Kits logo . Dorner recommends keeping these parts on hand.

End Drive Tail

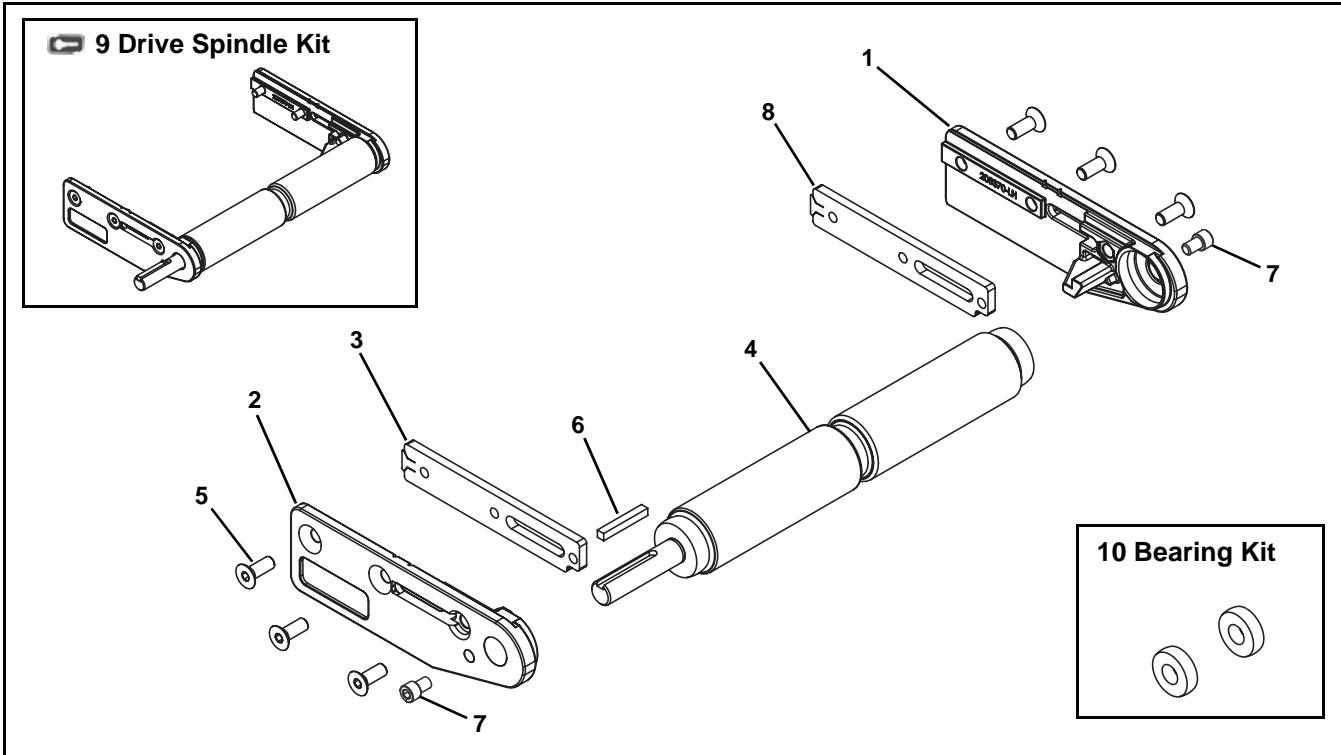

Service Parts

Item	Part Number	Description
1	205370-LH	Head Plate, Left Hand
2	205370-RH	Head Plate, Right Hand
3	206006	Tail Nut Bar for V-Guided Belts
	206006-RHBEND	Tail Nut Bar for Non V-Guided Belts
4	203713- <u>WW</u>	Knurled Spindle Assembly (One Keyed Shaft)
	203714- <u>WW</u>	Dual Shaft Knurled Spindle Assembly (Two Keyed Shafts)
	203717- <u>WW</u>	Common Drive - Knurled Conveyor Spindle Assembly (Keyed Shaft & Stub Shaft)
	203716- <u>WW</u>	Common Drive - Knurled Mid Conveyor Spindle Assembly (Two Stub Shafts)
	203715- <u>WW</u>	Common Drive - Knurled End Conveyor Spindle Assembly (One Stub Shaft)
	203723- <u>WW</u>	Lagged Drive Spindle (One Keyed Shaft)
	203724- <u>WW</u>	Lagged Dual Shaft Drive Spindle (Two Keyed Shafts)
	203727- <u>WW</u>	Lagged Common Drive - Drive Conveyor Spindle (Keyed Shaft & Stub Shaft)
	203726- <u>WW</u>	Lagged Common Drive - Mid Conveyor Spindle (Two Stub Shafts)
	203725- <u>WW</u>	Lagged Common Drive - End Conveyor Spindle (One Stub Shaft)
5	930616M	Flat Head Screw, M6-1.00 x 16 mm
6	980428M	Square Key, 4 mm x 28 mm
7	807-2979	Socket Head Screw, 1/4-28 x .375"
8	206006	Tail Nut Bar for V-Guided Belts
	206006-LHBEND	Tail Nut Bar for Non V-Guided Belts

Item	Part Number	Description	
9	22V2FO- <u>WW</u>	Knurled Spindle Kit (One Keyed Shaft) (Includes Items 1, 2, 4, 5 and 6)	
	22V2FK- <u>WW</u>	Dual Shaft Knurled Spindle Kit (Two Keyed Shafts) (Includes Items 1, 2, 4, 5 and 6)	
	22V2FS- <u>WW</u>	Common Drive - Knurled Conveyor Spindle Kit (Keyed Shaft & Stub Shaft) (Includes Items 1, 2, 4, 5 and 6)	
	22V2FE- <u>WW</u>	Common Drive - Knurled End Conveyor Spindle Kit (One Stub Shaft) (Includes Items 1, 2, 4, 5 and 6)	
	22V2FC- <u>WW</u>	Common Drive - Knurled Mid Conveyor Spindle Kit (Two Stub Shafts) (Includes Items 1, 2, 4, 5 and 6)	
	22V2FLO- <u>WW</u>	Lagged Drive Spindle Kit (One Keyed Shaft) (Includes Items 1, 2, 4, 5 and 6)	
	22V2FLK- <u>WW</u>	Lagged Dual Shaft Drive Spindle Kit (Two Keyed Shafts) (Includes Items 1, 2, 4, 5 and 6)	
	22V2FLS- <u>WW</u>	Lagged Common Drive - Drive Conveyor Spindle Kit (Keyed Shaft & Stub Shaft) (Includes Items 1, 2, 4, 5 and 6)	
	22V2FLE- <u>WW</u>	Lagged Common Drive - End Conveyor Spindle Kit (One Stub Shaft) (Includes Items 1, 2, 4, 5 and 6)	
	22V2FLC- <u>WW</u>	Lagged Common Drive - Mid Conveyor Spindle Kit (Two Stub Shafts) (Includes Items 1, 2, 4, 5 and 6)	
	10	22BK2	Bearing Kit (2 Pack)
		22BK4	Bearing Kit (4 Pack)
	<u>WW</u> = Conveyor width reference: 02, 03, 04, 05, 06, 08, 10, 12, 14, 16, 18, 20, 22, & 24		

Service Parts

iDrive Tail

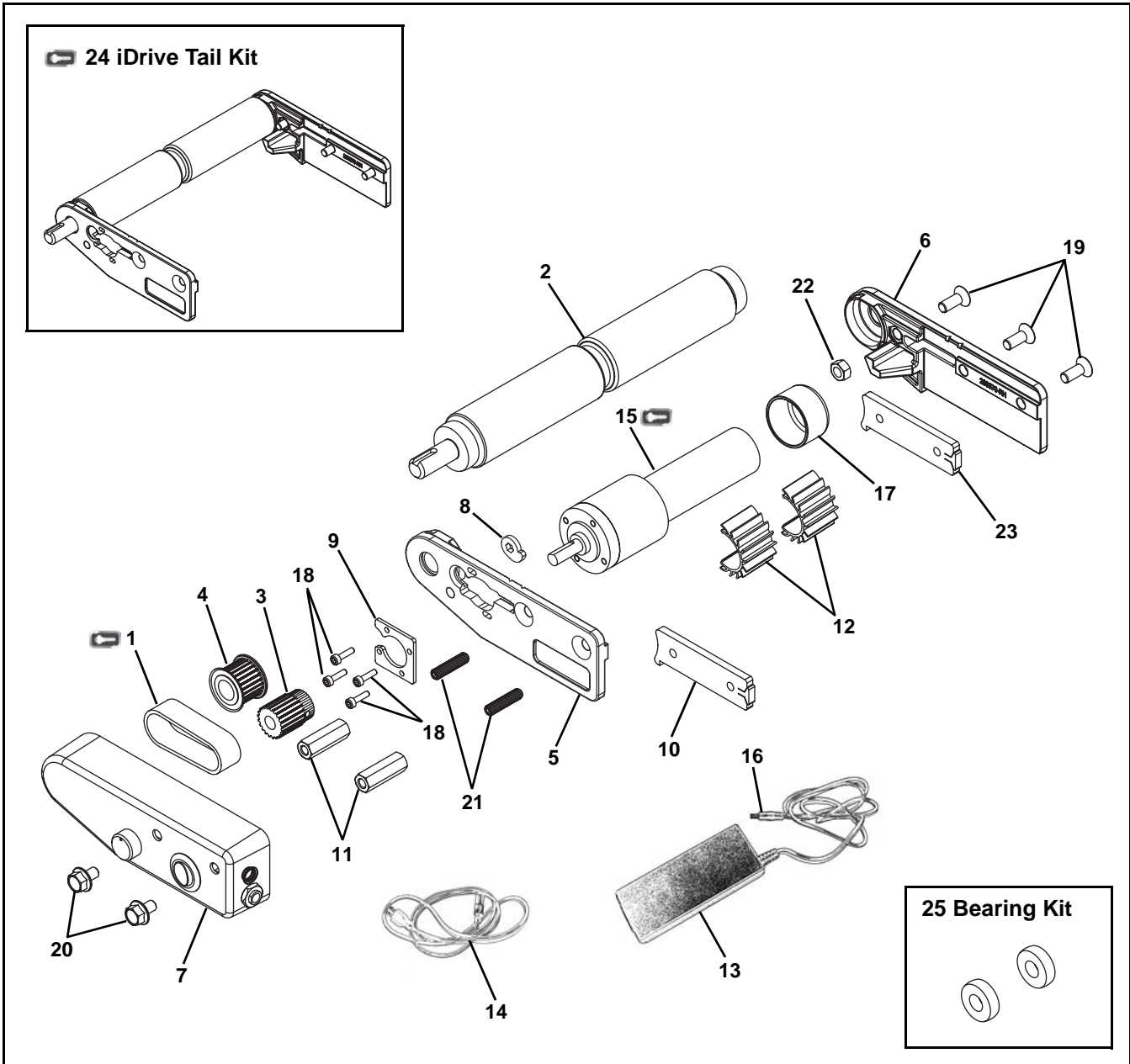

Service Parts

Item	Part Number	Description
1	814-450	Timing Belt, 3 mm x 50 teeth
2	201272- <u>WW</u>	Drive Spindle Assembly
	201278- <u>WW</u>	Lagged Drive Spindle Assembly
3	201330	Drive Pulley - 17 Tooth
	201331	Drive Pulley - 21 Tooth
4	203203	Driven Pulley - 24 Tooth
	203204	Driven Pulley - 28 Tooth
5	206795-LH	Head Plate, A position
	206795-RH	Head Plate, D position
6	206799-LH	Non-Drive Head Plate, for 2" - 4" wide A position
	206799-RH	Non-Drive Head Plate, for 2" - 4" wide D position
	205370-LH	Non-Drive Head Plate, for 5" wide and wider A position
	205370-RH	Non-Drive Head Plate, for 5" wide and wider D position
7	22FDEAA	Electrical Assembly, with speed direction control for A position
	22FDEAD	Electrical Assembly, with speed direction control for D position
	22FDC6A	Electrical Assembly, with customer wired control for A position, 6' cable
	22FDC6D	Electrical Assembly, with customer wired control for D position, 6' cable
	22FDC30A	Electrical Assembly, with customer wired control for A position, 30' cable
	22FDC30D	Electrical Assembly, with customer wired control for D position, 30' cable
	22FDR6A	Electrical Assembly, with speed, direction, and 6' remote start/stop cable for A position
	22FDR6D	Electrical Assembly, with speed, direction, and 6' remote start/stop cable for D position
	22FDR30A	Electrical Assembly, with speed, direction, and 30' remote start/stop cable for A position
	22FDR30D	Electrical Assembly, with speed, direction, and 30' remote start/stop cable for D position
8	203729	Timing Belt Tension Cam
9	206045	Clamp Plate
10	203639	Nut Bar
	203639-LHBEND	Nut Bar
11	807-983	Hex Standoff
12	807-1982	Heat Sink
13	831-139	Power Supply
14	818-164	Cord, 115V
15	22FDGM023	Gearmotor, 23:1
	22FDGM066	Gearmotor, 66:1
16	805-1316	Plug
17	807-2006	Motor Cap, for 2"-3" wide
18	920312M	Socket Head Screw, M3-.50 x 12 mm

Item	Part Number	Description
19	930616M	Flat Head Screw, M6-1.00 x 16 mm
20	960681M	Flange Head Hex Screw, M6-1.00 x 10 mm
21	970625MSS	Set Cup Screw, M6-1.00 x 25 mm
22	990601M	Hex Nut
23	203639	Nut Bar
	203639-RHBEND	Nut Bar
24	22V2FDKA- <u>WW</u>	iDrive Tail Kit for A position with Knurled Spindle (Includes Items 2, 5, 6, 19 and 22)
	22V2FDKD- <u>WW</u>	iDrive Tail Kit for D position with Knurled Spindle (Includes Items 2, 5, 6, 19 and 22)
	22V2FDLA- <u>WW</u>	iDrive Tail Kit for A position with Lagged Spindle (Includes Items 2, 5, 6, 19 and 22)
	22V2FDLD- <u>WW</u>	iDrive Tail Kit for D position with Lagged Spindle (Includes Items 2, 5, 6, 19 and 22)
25	22BK2	Bearing Kit (2 Pack)
	22BK4	Bearing Kit (4 Pack)
<u>WW</u> = Conveyor width reference: 02, 03, 04, 05, 06, 08, 10, 12, 14, 16 & 18		

Service Parts

Idler Tail

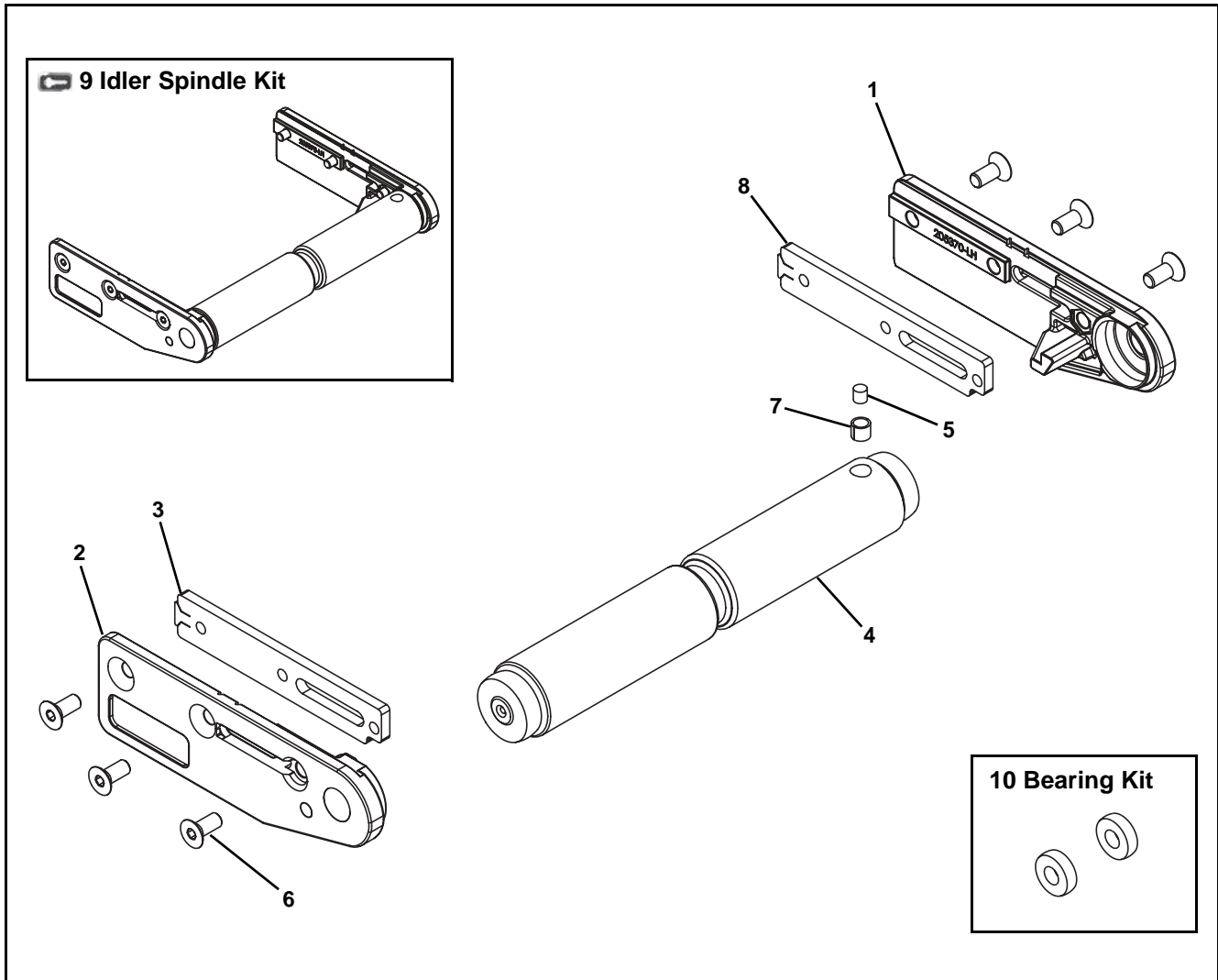

Item	Part Number	Description
1	205370-LH	Head Plate, Left Hand
2	205370-RH	Head Plate, Right Hand
3	206006	Tail Nut Bar for V-Guided Belts
	206006-RHBEND	Tail Nut Bar for Non V-Guided Belts
4	201273- <u>WW</u>	Standard Spindle Assembly
	203715- <u>WW</u>	Spindle with One Stub Shaft Assembly
	203713- <u>WW</u>	Spindle with Auxiliary Keyed Shaft Assembly
5	808-020	Magnet (Optional)
6	930616M	Flat Head Screw, M6-1.00 x 16 mm
7	450226SSP	Magnet Sleeve (Optional)
8	206006	Tail Nut Bar for V-Guided Belts
	206006-LHBEND	Tail Nut Bar for Non V-Guided Belts
9	22V2TO- <u>WW</u>	Standard Idler Spindle Kit (Includes Items 1, 2, 4, and 6)
	22V2TM- <u>WW</u>	Idler Spindle Kit with Magnet (Includes Items 1, 2, 4, 5, 6, and 7)
	22V2TS- <u>WW</u>	Idler Spindle Kit with One Stub Shaft (Includes Items 1, 2, 4, and 6)
	22V2TK- <u>WW</u>	Idler Spindle Kit with One Keyed Shaft (Includes Items 1, 2, 4, and 6)
10	22BK2	Bearing Kit (2 Pack)
	22BK4	Bearing Kit (4 Pack)
<u>WW</u> = Conveyor width reference: 02, 03, 04, 05, 06, 08, 10, 12, 14, 16, 18, 20, 22, & 24		

Service Parts

5/16" (8 mm) Tight Radius Nosebar Tail

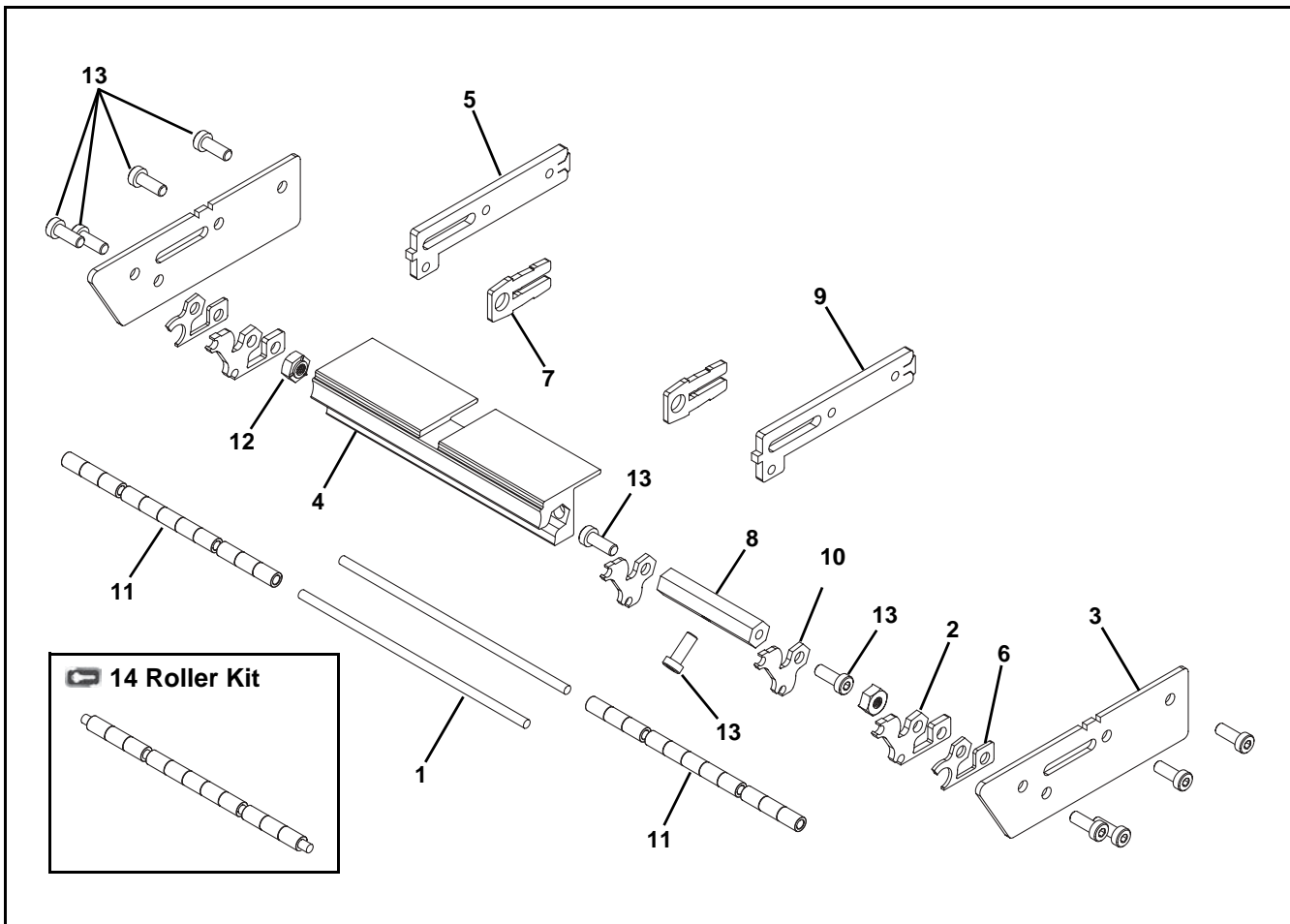

Item	Part Number	Description
1	2413 WW	Rod
2	206778	Inner End Plate
3	206777	Side Plate
4	206286- WW	Support Bar
5	206007	Tail Nut Bar for V-Guided Belts
	206007-RHBEND	Tail Nut Bar for Non V-Guided Belts
6	206010	Outer End Plate
7	205450	Retaining Plate
8	See Chart	Hex Rod
9	206007	Tail Nut Bar for V-Guided Belts
	206007-LHBEND	Tail Nut Bar for Non V-Guided Belts
10	206779	Rod Carrier Plate
11	801-180	Bearing
12	807-2873	Weld Nut
13	950616M	Low Head Cap Screw, M6-1.00 x 16 mm
14	22V2L- WW	Roller Kit (Includes Items 1 and 11)

~~WW~~ = Conveyor width reference: 02, 03, 04, 05, 06, 08, 10, 12, 14, 16, 18, 20, 22, & 24

Item #8 Hex Rod		
Width	Part Number	Quantity
02	N/A	0
03	N/A	0
04	206060	1
05	206059	1
06	206059	1
08	206059	1
10	206060	2
12	206059	2
14	206060	3
16	206060	3
18	206060	4
20	206060	4
22	206059	4
24	206059	4

5/8" (16 mm) Nosebar Tail

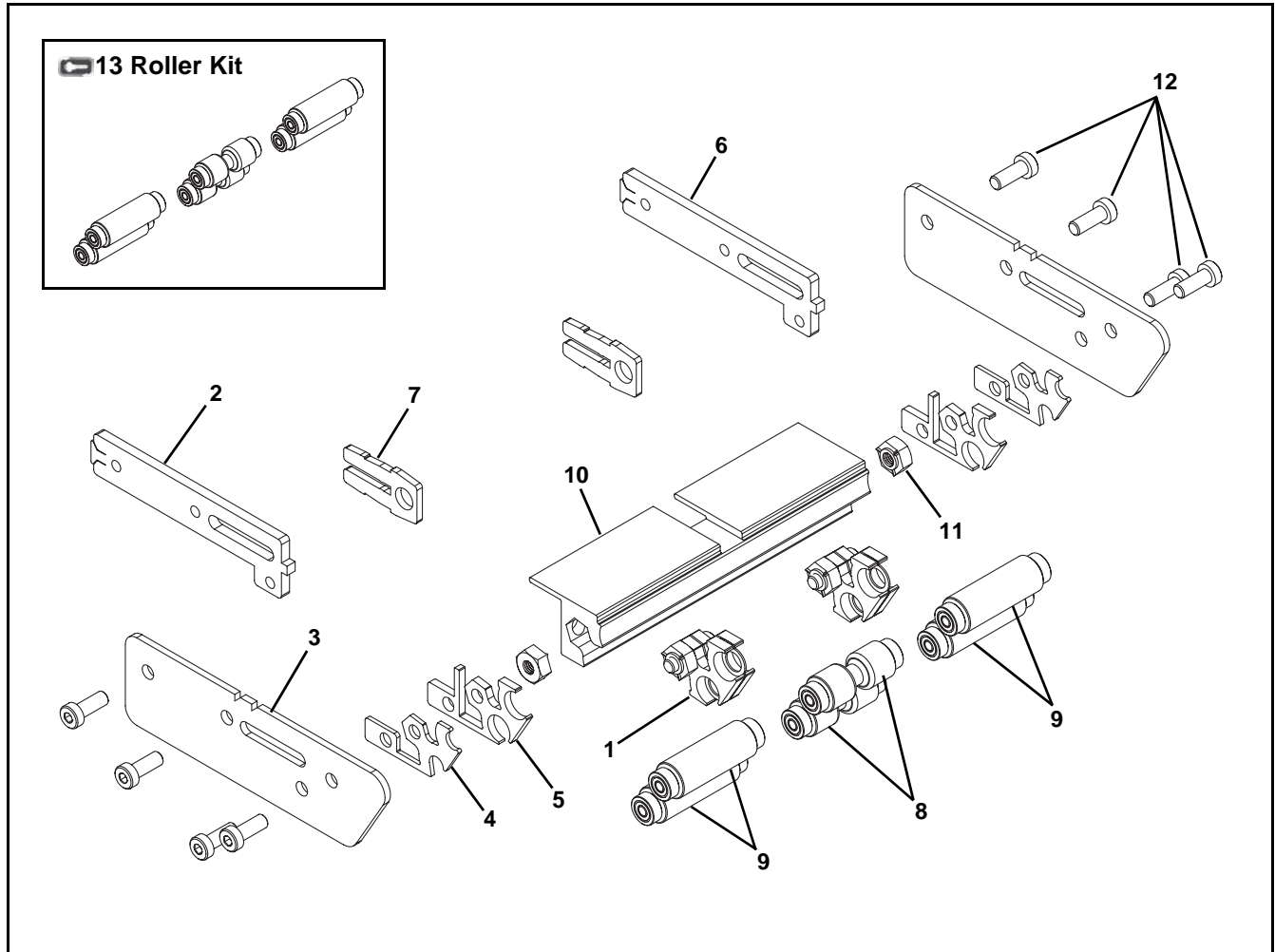

Item	Part Number	Description
1	205523	Carrier Bearing (for conveyors 5" wide and wider)
2	206007	Tail Nut Bar for V-Guided Belts
	206007-RHBEND	Tail Nut Bar for Non V-Guided Belts
3	206009	Tail Plate
4	206010	Outer End Plate
5	206011	Inner End Plate
6	206007	Tail Nut Bar for V-Guided Belts
	206007-LHBEND	Tail Nut Bar for Non V-Guided Belts
7	205450	Retaining Plate
8	205526- <u>WW</u>	V-Groove Spindle Assembly
9	205527- <u>WW</u>	Smooth Spindle Assembly (for conveyors 5" wide and wider)
10	206286- <u>WW</u>	Support Bar
11	807-2873	Weld Nut
12	950616M	Low Head Cap Screw, M6-1.00 x 16 mm
13	22V2H- <u>WW</u>	Roller Kit (Includes Items 8 and 9)

WW = Conveyor width reference: 02, 03, 04, 05, 06, 08, 10, 12, 14, 16, 18, 20, 22, & 24

Service Parts

Item	Part Number	Description
1	203628	Bearing Mounting Block w/Hole
2	203632	Tensioner Bar Tab, for 4" - 24" wide conveyors
3	203681	Pivot Tension Plate
4	204566	Mounting Clip
5	205446	Inside Mounting Plate
6	205447	Outside Mounting Plate
7	463037	Grooved Roller, for 2" wide Conveyor
	463038	Grooved Roller, for 3" wide Conveyor
	463039	Grooved Roller, for 4" wide Conveyor
	203633- <u>WW</u>	Grooved Roller, for 5" - 24" wide Conveyors
8	463040	Smooth Roller, for 2" wide Conveyor
	463041	Smooth Roller, for 3" wide Conveyor
	463042	Smooth Roller, for 4" wide Conveyor
	203635- <u>WW</u>	Smooth Roller, for 5" - 24" wide Conveyors
9	202633M	Side Plate, Left Hand
10	202634M	Side Plate, Right Hand
11	203631- <u>WW</u>	Tensioner Rail
	463302	Tensioner Rail, for 2" wide Conveyor
	463303	Tensioner Rail, for 3" wide Conveyor
12	203713- <u>WW</u>	Drive Spindle Assembly
	203714- <u>WW</u>	Dual Shaft Drive Spindle Assembly
	203723- <u>WW</u>	Lagged Drive Spindle
	203724- <u>WW</u>	Lagged Dual Shaft Drive Spindle
13	4632 <u>WW</u> M	Bottom Cover, for 2"- 14" & 18" wide Conveyors
	463208M	Bottom Cover, for 16" wide Conveyors (qty. 2)
	463210M	Bottom Cover, for 20" wide Conveyors (qty. 2)
	463212M	Bottom Cover, for 22" wide Conveyors
	463205M	Bottom Cover, for 22" wide Conveyors (qty. 2)
	463212M	Bottom Cover, for 24" wide Conveyors (qty. 2)
14	4638 <u>WW</u>	Support Rail
15	674175MP	Square Nut, M6
16	708180P	Trilobe Screw, M6-1.00 x 25 mm
17	801-138	Bearing
18	801-173	Bearing
19	807-1040	Gas Spring, for 2" wide Conveyor
	807-986	Gas Spring, for 3" wide Conveyor
	807-985	Gas Spring, for 4"- 6" & 12"- 24" wide Conveyors
	807-984	Gas Spring, for 8"- 10" wide Conveyors
20	203728	Bearing Mounting Block
21	807-2885	Washer
22	807-987	Steel Ball Joint M6 x M8
23	920510M	Socket Head Screw, M5-.80 x 10 mm

Item	Part Number	Description
24	920612M	Socket Head Screw, M6-1.00 x 12 mm
25	920616M	Socket Head Screw, M6-1.00 x 16 mm
26	920635M	Socket Head Screw, M6-1.00 x 35 mm
27	950610M	Low Head Cap Screw, M6-1.00 x 10 mm
28	980428M	Square Key, 4mm x 28 mm
29	990503M	Square Nut, M5
30	990801M	Hex Nut, M8
31	22V2CDKO- <u>WW</u>	Center Drive Repair Kit (Includes Items 7, 8, & 12)
	22V2CDKE- <u>WW</u>	Center Drive Repair Kit for Dual Shaft Spindle (Includes Items 7, 8, & 12)
	22V2CDLO- <u>WW</u>	Center Drive Repair Kit for Lagged Drive Spindle (Includes Items 7, 8, & 12)
	22V2CDLE- <u>WW</u>	Center Drive Repair Kit for Lagged Dual Shaft Spindle (Includes Items 7, 8, & 12)
32	22BK2	Bearing Kit (2 Pack)
	22BK4	Bearing Kit (4 Pack)

WW = Conveyor width ref.: 02, 03, 04, 05, 06, 08, 10, 12, 14, 16, 18, 20, 22, & 24

Service Parts

Mid Drive Module

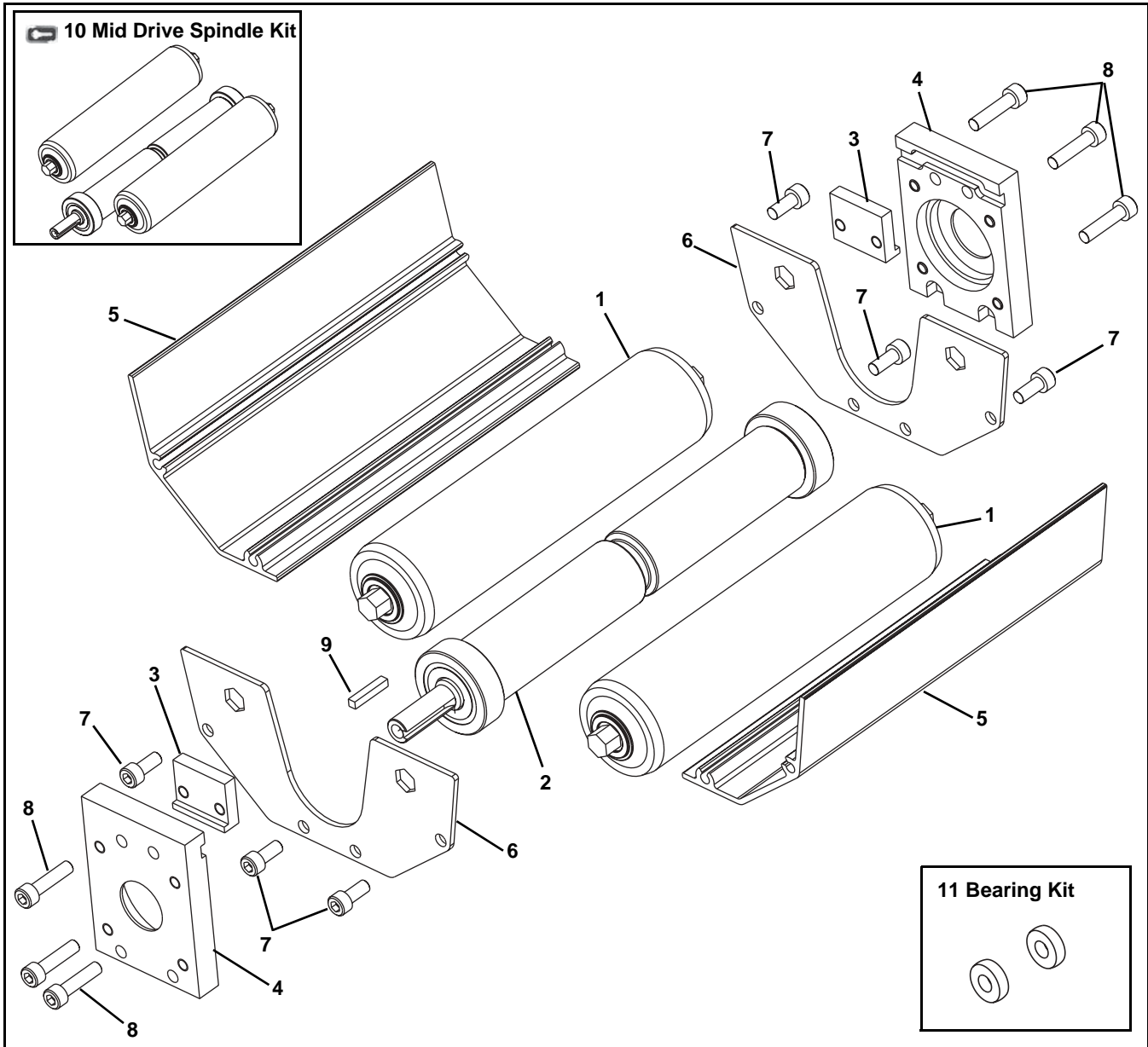

Item	Part Number	Description
1	463040	Idler Roller Assembly for 2" wide Conveyor
	463041	Idler Roller Assembly for 3" wide Conveyor
	463042	Idler Roller Assembly for 4" wide Conveyor
	203635- <u>WW</u>	Idler Roller Assembly for 5" wide and wider Conveyors
2	203713- <u>WW</u>	Knurled Spindle Assembly
	203714- <u>WW</u>	Knurled Spindle Assembly - Dual Shaft
	203723- <u>WW</u>	Lagged Spindle Assembly
	203724- <u>WW</u>	Lagged Spindle Assembly - Dual Shaft
3	202353	Clamp Block
4	203637	Mounting Block
5	202455- <u>WW</u>	Bottom Guard
6	202456	Side Plate
7	920614M	Socket Head Screw, M6-1.00 x 14 mm
8	920625M	Socket Head Screw, M6-1.00 x 25 mm
9	980428M	Square Key 4 mm x 28 mm
10 	22V2MDKO- <u>WW</u>	Mid Drive Spindle Kit for Knurled Spindle (includes items 1 and 2)
	22V2MDKE- <u>WW</u>	Mid Drive Spindle Kit for Knurled Spindle - Dual Shaft (includes items 1 and 2)
	22V2MDLO- <u>WW</u>	Mid Drive Spindle Kit for Lagged Spindle (includes items 1 and 2)
	22V2MDLE- <u>WW</u>	Mid Drive Spindle Kit for Lagged Spindle - Dual Shaft (includes items 1 and 2)
11	22BK2	Bearing Kit (2 Pack)
	22BK4	Bearing Kit (4 Pack)
<u>WW</u> = Conveyor Width Reference: 02, 03, 04, 05, 06, 08, 10, 12, 14, 16, 18, 20, 22, & 24		

Service Parts

Frame Assembly

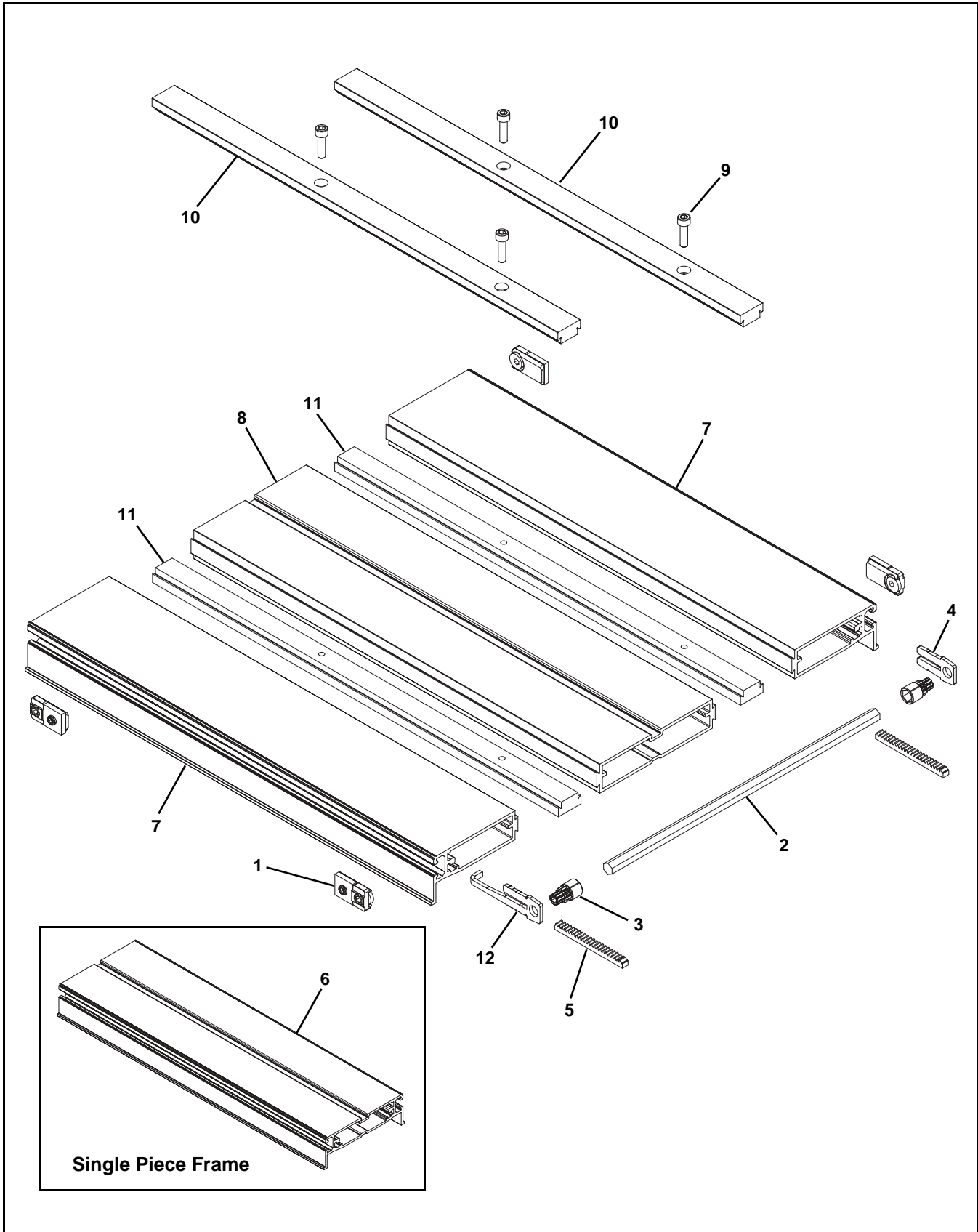

Item	Part Number	Description
1	203597	Tracking Block Assembly
2	205469- <u>WW</u>	Hex Pinion, for 3"- 24" wide Conveyors
3	207145	Pinion End Gear, for 2" wide Conveyors
	205383	Pinion End Gear, for 3"- 24" wide Conveyors
4	205450	Retaining Plate - Left Hand
5	203596	Gear Rack
6	203629- <u>WW-LLLLL</u>	Single Piece Frame, for 2"- 12" wide Conveyors
	207365- <u>WW-LLLLL</u>	Single Piece Frame, for Cleated Belt LPZ Conveyors Only
7	205393- <u>LLLLL</u>	Outside Frame, for Multi Piece 14" & 20" wide Conveyors (Qty. 2)
	207366- <u>LLLLL</u>	Outside Frame, for Cleated Belt LPZ 14" & 20" wide Conveyors Only (Qty. 2)
	205394- <u>LLLLL</u>	Outside Frame, for Multi Piece 16" & 22" wide Conveyors (Qty. 2)
	207367- <u>LLLLL</u>	Outside Frame, for Cleated Belt LPZ 16" & 22" wide Conveyors Only (Qty. 2)
	205395- <u>LLLLL</u>	Outside Frame, for Multi Piece 18" & 24" wide Conveyors (Qty. 2)
	207368- <u>LLLLL</u>	Outside Frame, for Cleated Belt LPZ 18" & 24" wide Conveyors Only (Qty. 2)
8	205396- <u>LLLLL</u>	Mid Frame, for Multi Piece 14" - 18" wide Conveyors
	207369- <u>LLLLL</u>	Mid Frame, for Cleated Belt LPZ 14" - 18" wide Conveyors Only
	205398- <u>LLLLL</u>	Mid Frame, for Multi Piece 20" - 24" wide Conveyors
	207370- <u>LLLLL</u>	Mid Frame, for Cleated Belt LPZ 20" - 24" wide Conveyors Only
9	920622M	Socket Head Screw, M6-1.00 x 22 mm
10	206505- <u>LLLLL</u>	Upper Connecting Strip
	207371- <u>LLLLL</u>	Upper Connecting Strip, for Cleated Belt LPZ Conveyors Only
11	206506- <u>LLLLL</u>	Lower Connecting Strip
12	205450RH	Retaining Plate - Right Hand
<u>WW</u> = Conveyor width reference: 02, 03, 04, 05, 06, 08, 10, 12, 14, 16, 18, 20, 22, & 24		
<u>LLLLL</u> = part length in inches with 2 decimal places		
Example: Part length = 35.25" <u>LLLLL</u> = 03525		

Service Parts

Flat Belt Knuckle

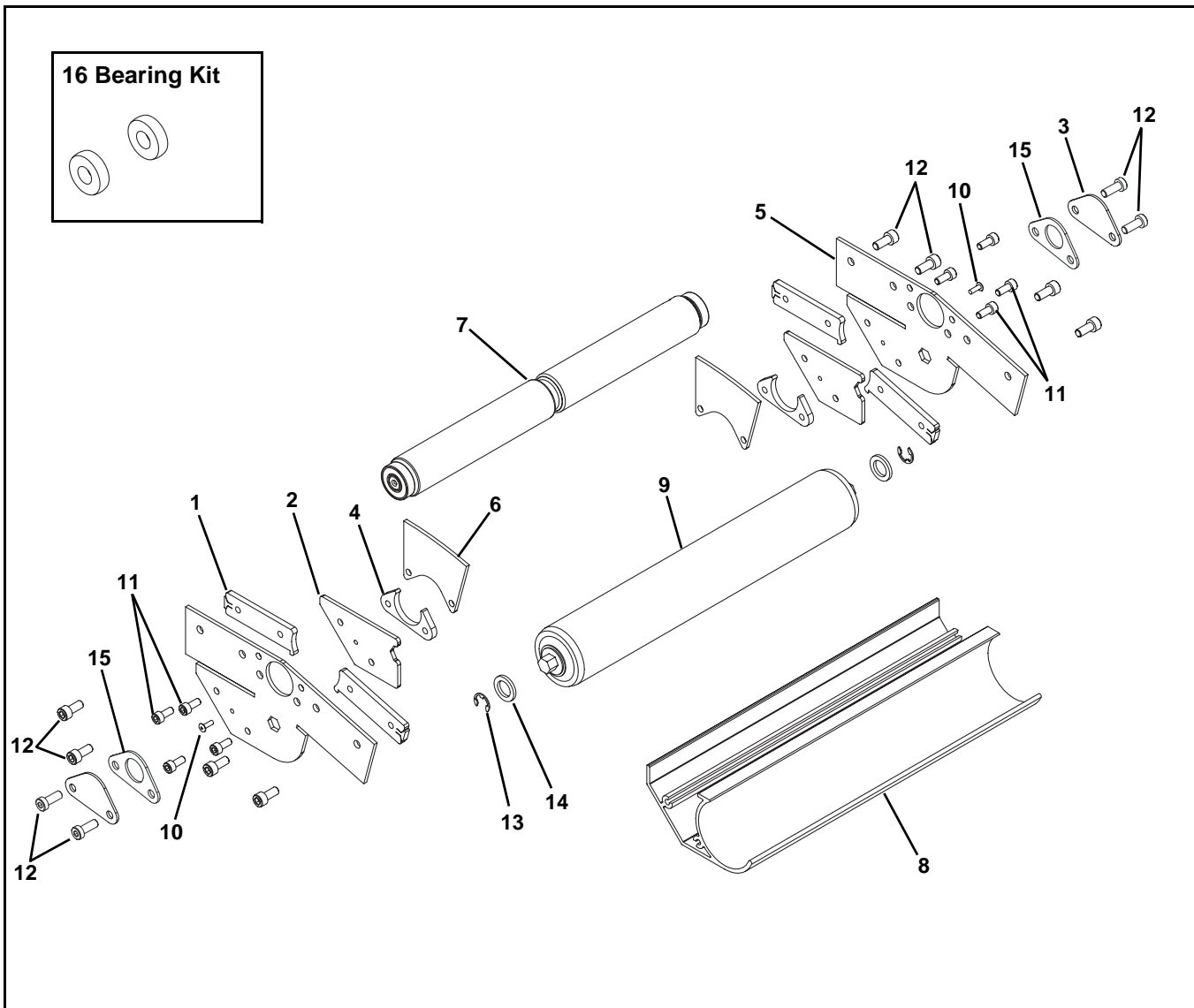

Item	Part Number	Description
1	203639	Nut Bar
2	206394	Spacer
3	206690	Bearing Cover
4	206691	Bearing Housing
5	206393- <u>AA</u>	Outer Plate
6	206688- <u>AA</u>	Knuckle Guide for # 04 Profiles only
	206689- <u>AA</u>	Knuckle Guide for # 05 Profiles only
7	201273- <u>WW</u>	Spindle Assembly
8	207221- <u>WW</u>	Return Roller Cover
9	463040	Roller Assembly for 2" wide Conveyor
	463041	Roller Assembly for 3" wide Conveyor
	463042	Roller Assembly for 4" wide Conveyor
	203635- <u>WW</u>	Roller Assembly for 5" wide and wider Conveyors

Item	Part Number	Description
10	914-005	Rivet
11	920512M	Socket Head Screw, M5-.80 x 12 mm
12	950616M	Low Head Screw, M6-1.00 x 16 mm
13	915-215	Retaining Ring (for 2" - 4" wide only)
14	801-115	Washer (for 2" - 4" wide only)
15	207222	Bearing Spacer
16	22BK2	Bearing Kit (2 Pack)
	22BK4	Bearing Kit (4 Pack)

AA = Angle 5, 10, 15, and 20
WW = Conveyor width reference: 02, 03, 04, 05, 06, 08, 10, 12, 14, 16, 18, 20, 22, & 24

Cleated Belt Lower Knuckle

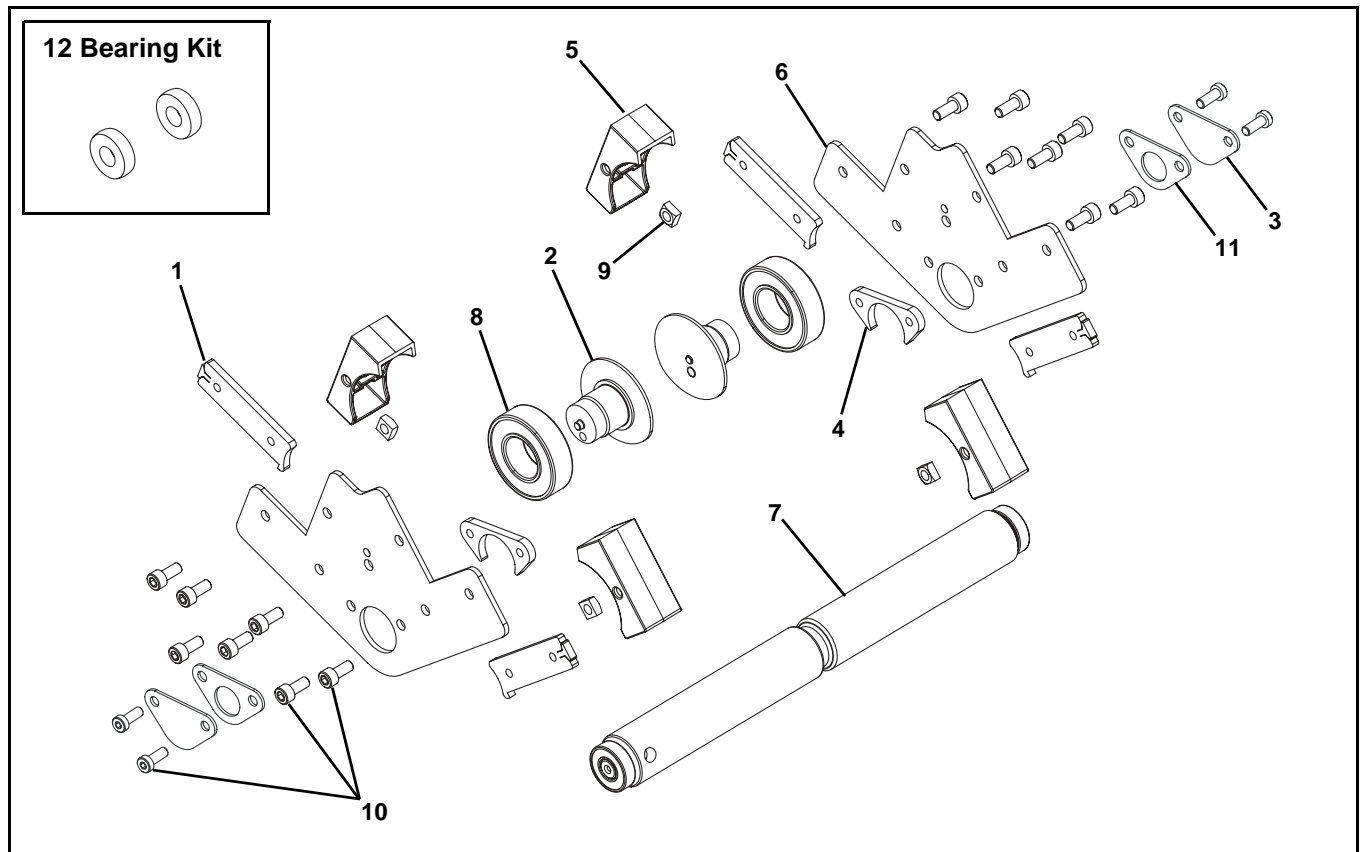

Item	Part Number	Description
1	203639	Nut Bar
2	206021	Bearing Stub Assembly
3	206690	Bearing Cover
4	206691	Bearing Housing
5	206693	Bearing Guard for 30°
	206379-AA	Bearing Guard for 45° and 60°
6	206387-AA	Outer Plate
7	201273-WW	Spindle Assembly
8	802-109	Bearing 25 mm x 52 mm
9	807-920	Square Nut
10	950616M	Low Head Screw, M6-1.00 x 16 mm
11	207222	Bearing Spacer
12	22BK2	Bearing Kit (2 Pack)
	22BK4	Bearing Kit (4 Pack)
AA = Angle 30, 45, 60		
WW = Conveyor width reference: 06, 08, 10, 12, 14, 16, 18, 20, 22, & 24		

Service Parts

Cleated Belt Upper Knuckle

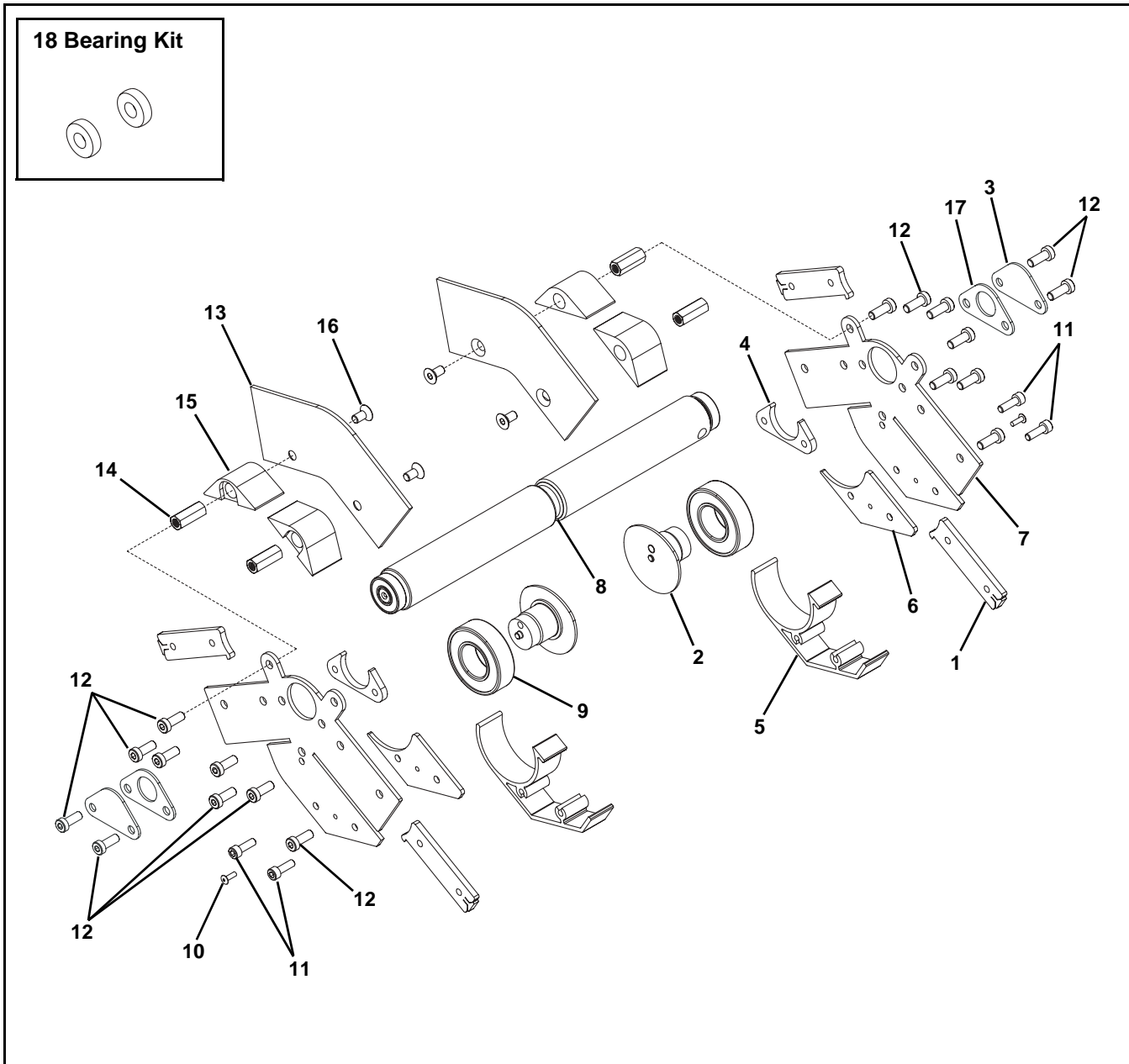

Item	Part Number	Description
1	203639	Nut Bar
2	206021	Bearing Stub Assembly
3	206690	Bearing Cover
4	206691	Bearing Housing
5	322501	Return Roller Cover
6	206390	Spacer
7	206391-AA	Outer Plate
8	201273-WW	Spindle Assembly
9	802-109	Bearing 25 mm x 52 mm
10	914-005	Rivet
11	920516M	Socket Head Screw, M5-.80 x 16 mm

Item	Part Number	Description
12	950616M	Low Head Screw, M6-1.00 x 16 mm
13	206049-AA	Guide
14	807-2862	Hex Standoff
15	206389	Spacer
16	930612M	Flat Head Screw, M6-1.00 x 12 mm
17	207222	Bearing Spacer
18	22BK2	Bearing Kit (2 Pack)
	22BK4	Bearing Kit (4 Pack)
AA = Angle 30, 45, 60		
WW = Conveyor width reference: 06, 08, 10, 12, 14, 16, 18, 20, 22, & 24		

#04 Profile - 3.00" (76 mm) Aluminum Side

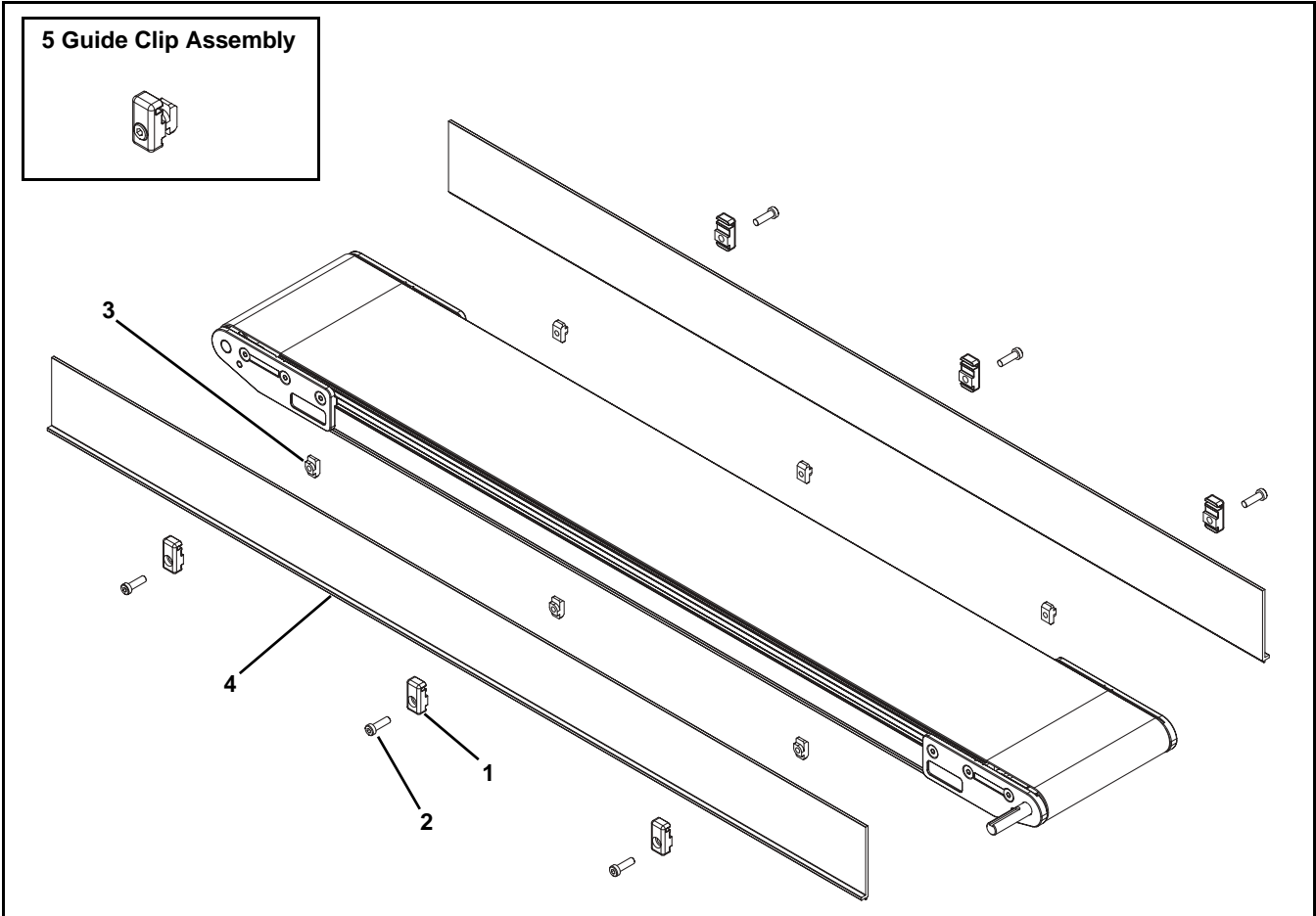

Item	Part Number	Description
1	206503	Guide Clip
2	807-2878	Low Head Cap Screw, M6-1.00 x 16 mm
3	206685	T-Nut
4	206514-LLLLL	3.00" Guides
	GTB04A04	3.00" Guides 4' long
	GTB04A08	3.00" Guides 8' long
5	203661	Guide Clip Assembly (Includes items 1, 2, and 3)
LLLLL = part length in inches with 2 decimal places		
Length Example: Length = 35.25" LLLLL = 03525		

Service Parts

#05 Profile - 1.50" (38 mm) Aluminum Side

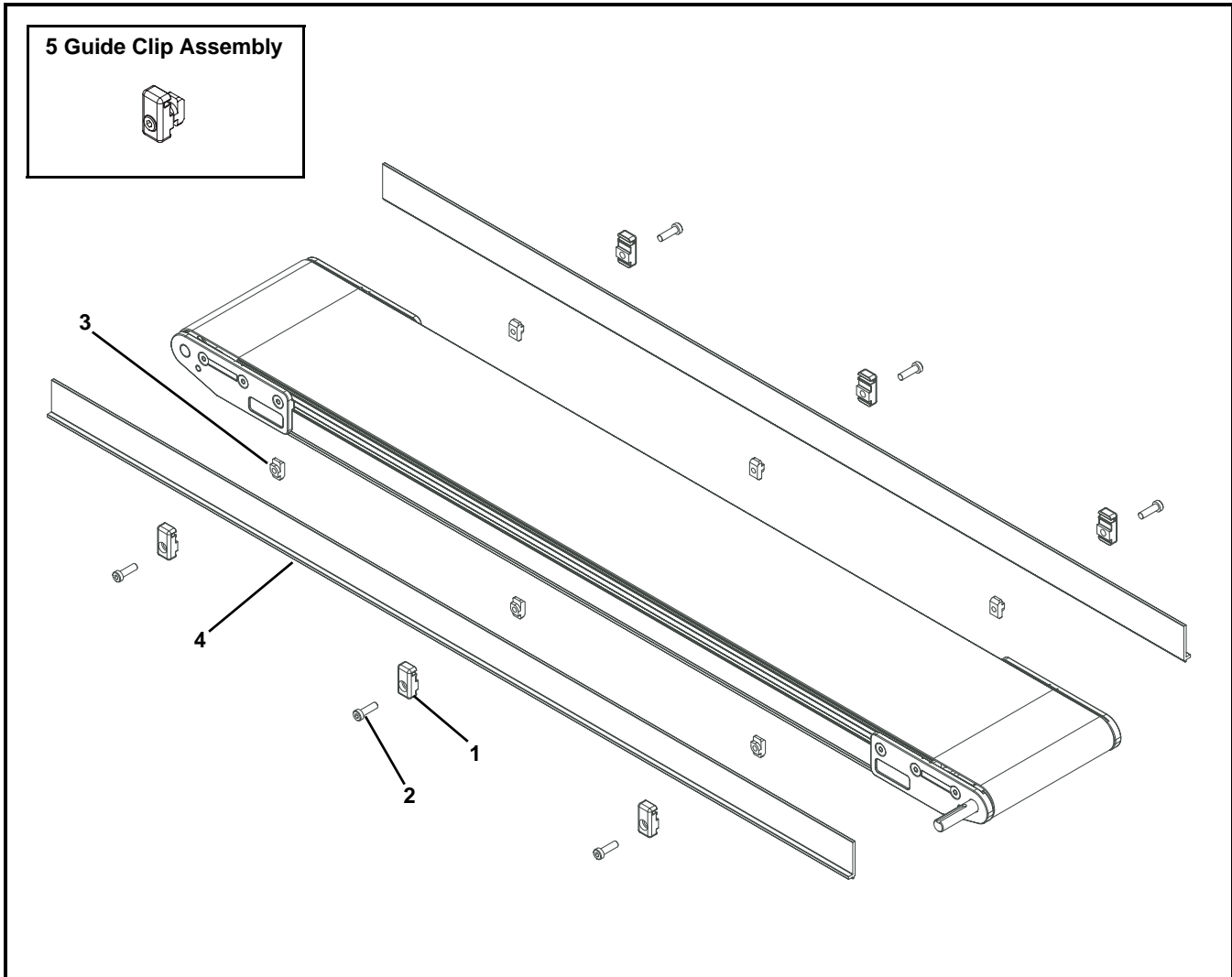

Item	Part Number	Description
1	206503	Guide Clip
2	807-2878	Low Head Cap Screw, M6-1.00 x 16 mm
3	206685	T-Nut
4	206513-LLLLL	1.50" Guides
	GTB05A04	1.50" Guides 4' long
	GTB05A08	1.50" Guides 8' long
5	203661	Guide Clip Assembly (Includes items 1, 2, and 3)
LLLLL = part length in inches with 2 decimal places		
Length Example: Length = 35.25" LLLLL = 03525		

#07 Profile - Low to Side Wiper

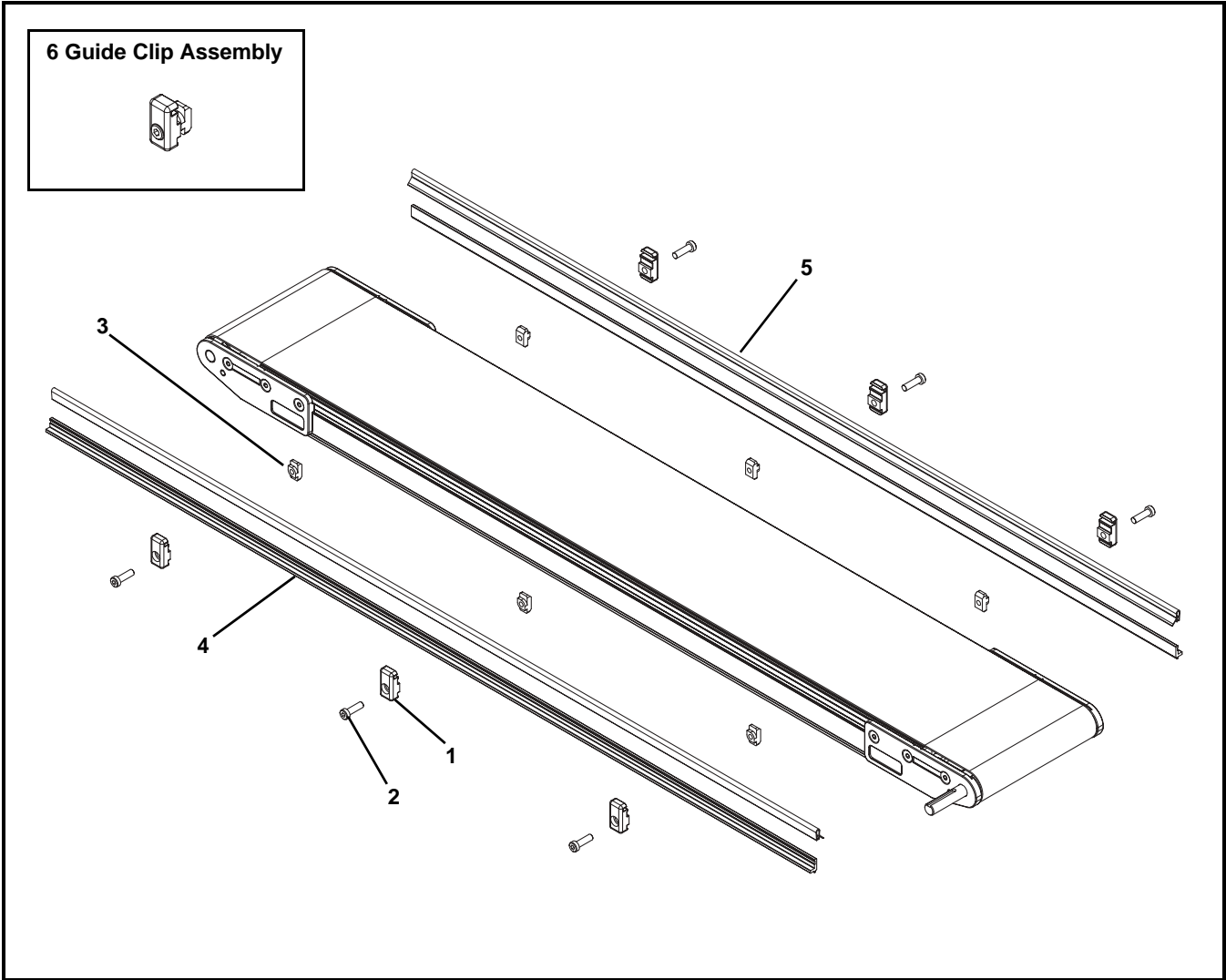

Item	Part Number	Description
1	207136	Guide Clip
2	807-2878	Low Head Cap Screw, M6-1.00 x 16 mm
3	206685	T-Nut
4	206512-LLLLL	.50" Guides
	GTB09A04	.50" Guides 4' long
	GTB09A08	.50" Guides 8' long
5	41-00-24	Side Wiper (per foot)
6	203662	Guide Clip Assembly (Includes items 1, 2, and 3)
LLLLL = part length in inches with 2 decimal places		
Length Example: Length = 35.25" LLLLL = 03525		

Service Parts

#09 Profile - Low to High Side

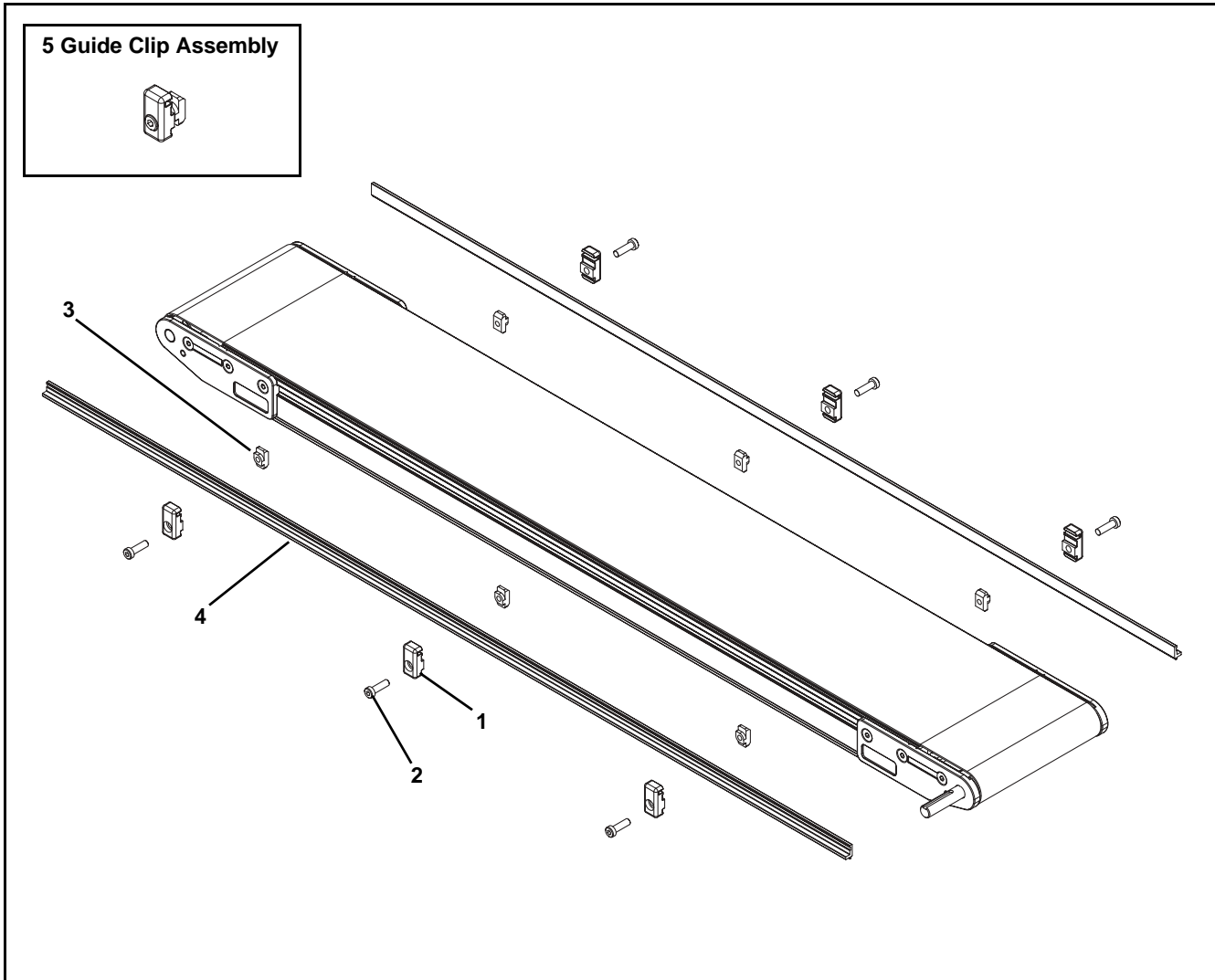

Item	Part Number	Description
1	206503	Guide Clip
2	807-2878	Low Head Cap Screw, M6-1.00 x 16 mm
3	206685	T-Nut
4	206512- <u>LLLLL</u>	.50" Guides
	GTB09A04	.50" Guides 4' long
	GTB09A08	.50" Guides 8' long
5	203661	Guide Clip Assembly (Includes items 1, 2, and 3)
<u>LLLLL</u> = part length in inches with 2 decimal places		
Length Example: Length = 35.25" <u>LLLLL</u> = 03525		

#10 Profile - .5" (13 mm) Extruded Plastic Side

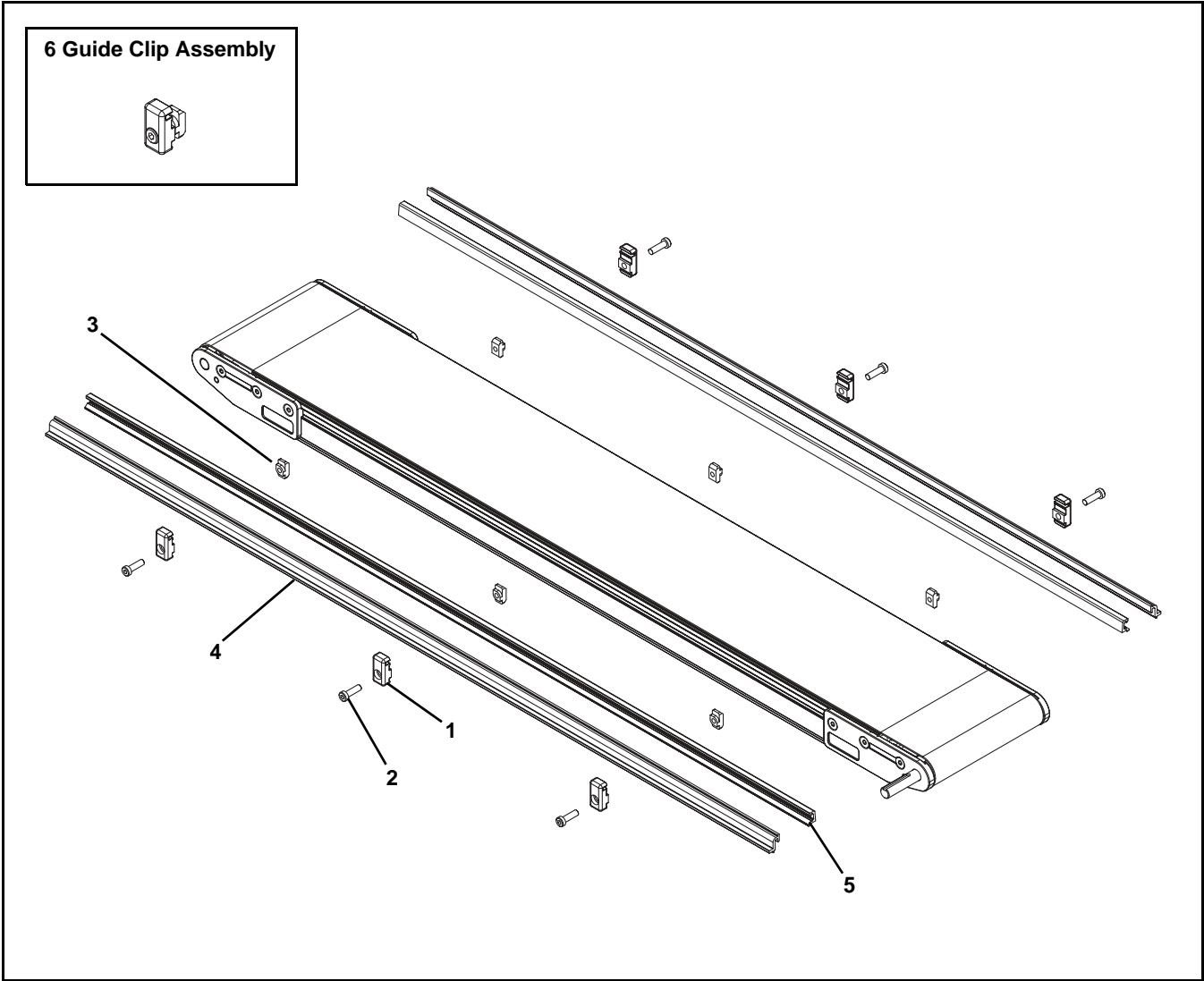

Item	Part Number	Description
1	206503	Guide Clip
2	807-2878	Low Head Cap Screw, M6-1.00 x 16 mm
3	206685	T-Nut
4	206511-LLLLL	.50" Guides
5	203770	Snap-On Guides (per foot)
6	203661P	Guide Clip Assembly (Includes items 1, 2, and 3)
LLLLL = part length in inches with 2 decimal places		
Length Example: Length = 35.25" LLLLL = 03525		

Service Parts

#13, 33 & 43 Profile - Adjustable Guiding

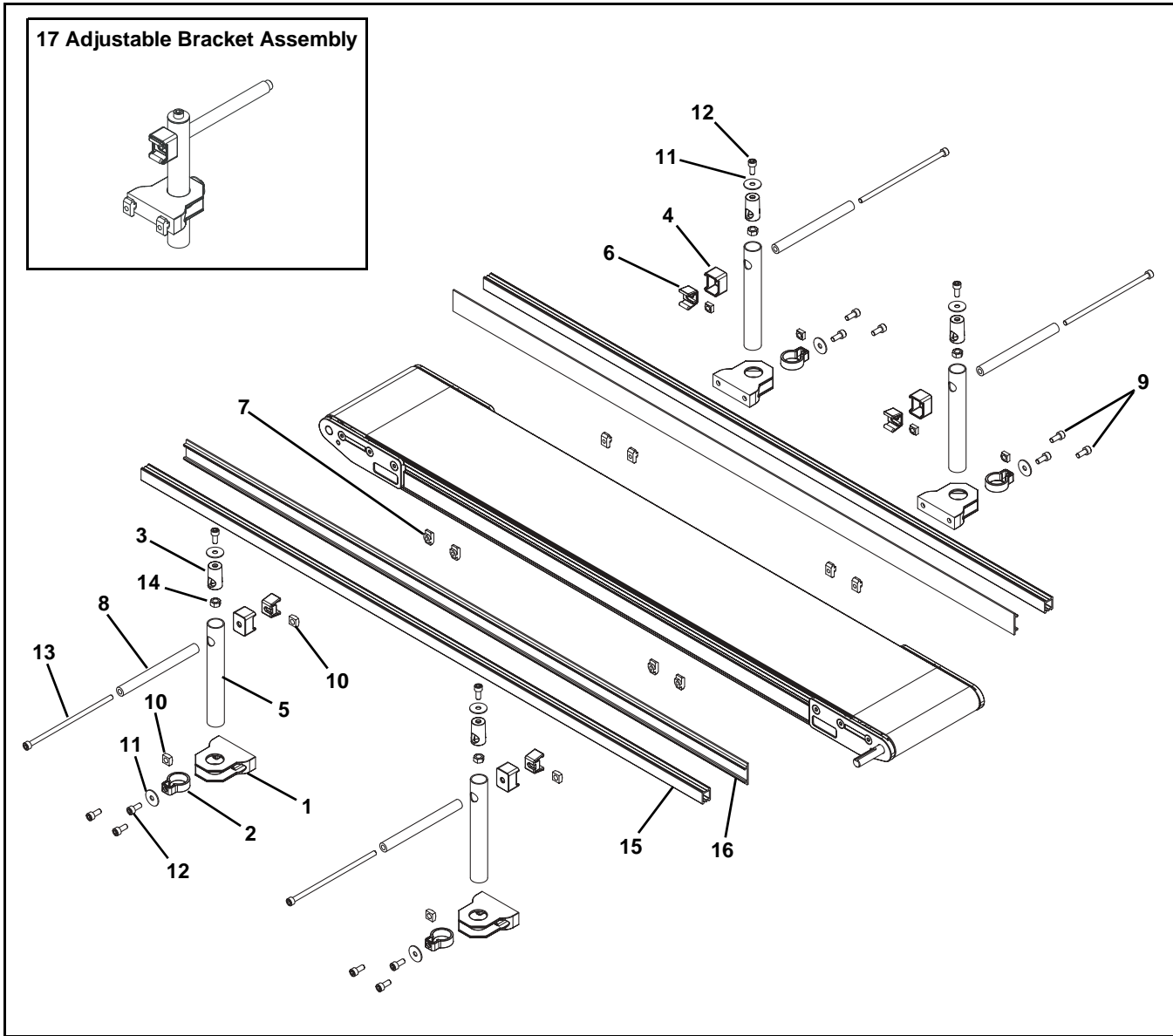

Item	Part Number	Description
1	206380	Base
2	206381	Base Clamp
3	206382	Insert Clamp
4	206383	Guide Ring
5	206385	Tube
6	206397	Clip
7	206685	T-Nut
8	206692	Guide Tube
9	807-2859	Nylon Cap Screw, N6 x 16 mm
10	807-920	Square Nut, M6-1.0
11	911-710	Washer
12	920616M	Socket Head Screw, M6-1.00 x 16 mm
13	9206150M	Socket Head Screw, M6-1.00 x 150 mm

Item	Part Number	Description
14	990601M	Hex Nut
15	834-238-LLLLL	Guide Rail
	GTB13A04	Guide Rail 4' long
	GTB13A08	Guide Rail 8' long
16	834-241	1.3" UHMW Guiding (per foot)
	GTB13B04	1.3" UHMW Guiding 4' long
	GTB13B08	1.3" UHMW Guiding 8' long
	206683	2" UHMW Guiding (per foot)
	GTB13C04	2" UHMW Guiding 4' long
GTB13C08	2" UHMW Guiding 8' long	
17	206686	Adjustable Bracket Assembly (Includes Items 1 through 14)

LLLLL = part length in inches with 2 decimal places
 Length Example: Length = 35.25" LLLLL = 03525

#14, 34 & 44 Profile - Tool-Less Adjustable Guiding

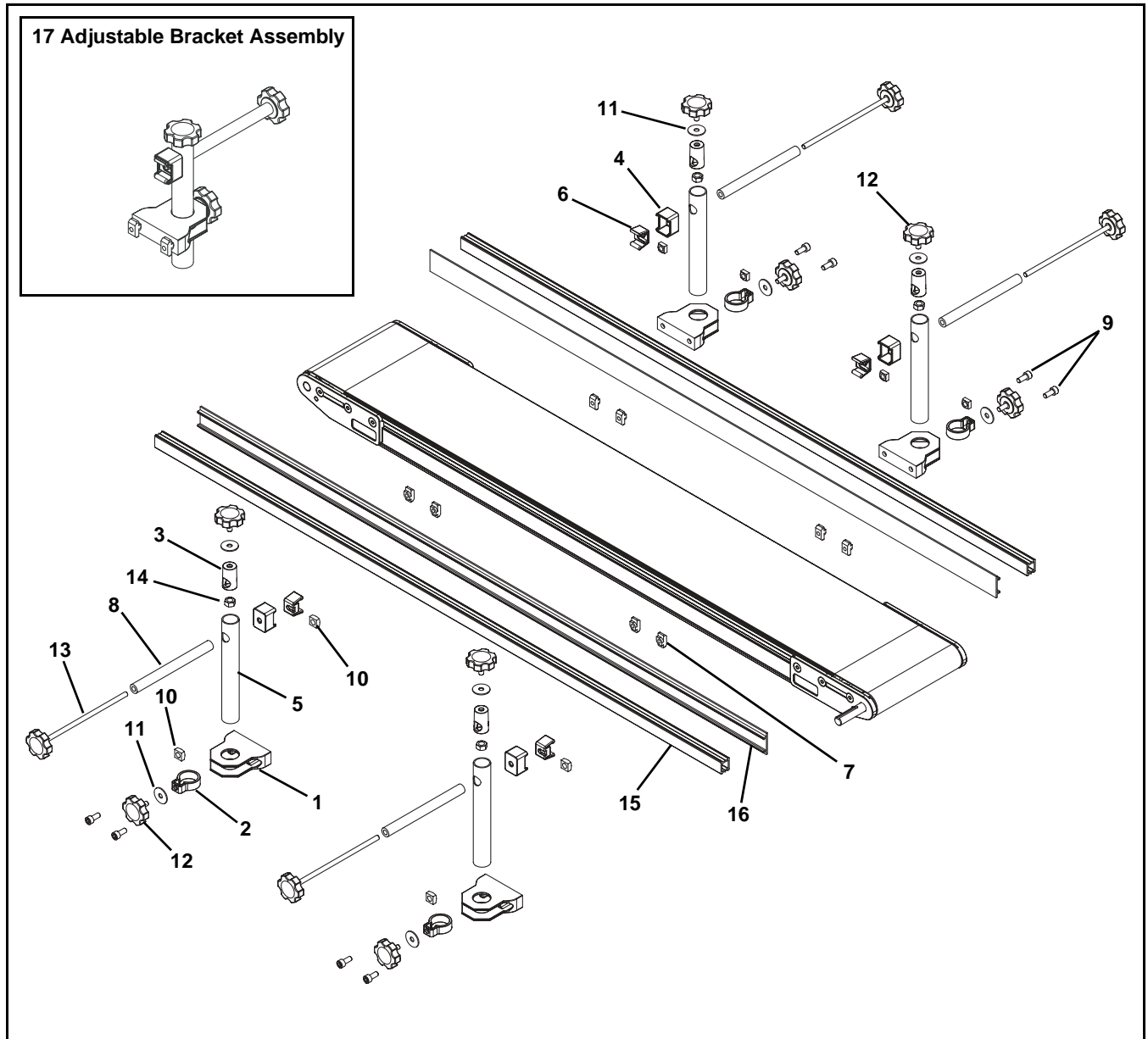

Item	Part Number	Description
1	206380	Base
2	206381	Base Clamp
3	206382	Insert Clamp
4	206383	Guide Ring
5	206385	Tube
6	206397	Clip
7	206685	T-Nut
8	206692	Guide Tube
9	807-2859	Nylon Cap Screw, N6 x 16 mm
10	807-920	Square Nut, M6-1.0
11	911-710	Washer
12	206698	Knob, 12 mm
13	206697	Knob, 150 mm
14	990601M	Hex Nut

Item	Part Number	Description
15	834-238- <u>LLLLL</u>	Guide Rail
	GTB13A04	Guide Rail 4' long
	GTB13A08	Guide Rail 8' long
16	834-241	1.3" UHMW Guiding (per foot)
	GTB13B04	1.3" UHMW Guiding 4' long
	GTB13B08	1.3" UHMW Guiding 8' long
	206683	2" UHMW Guiding (per foot)
	GTB13C04	2" UHMW Guiding 4' long
	GTB13C08	2" UHMW Guiding 8' long
17	206687	Tool-Less Adjustable Bracket Assembly (Includes Items 1 through 14)
		<u>LLLLL</u> = part length in inches with 2 decimal places
		Length Example: Length = 35.25" <u>LLLLL</u> = 03525

Service Parts

#16, 36 & 46 Profile - Outboard Adjustable Guiding

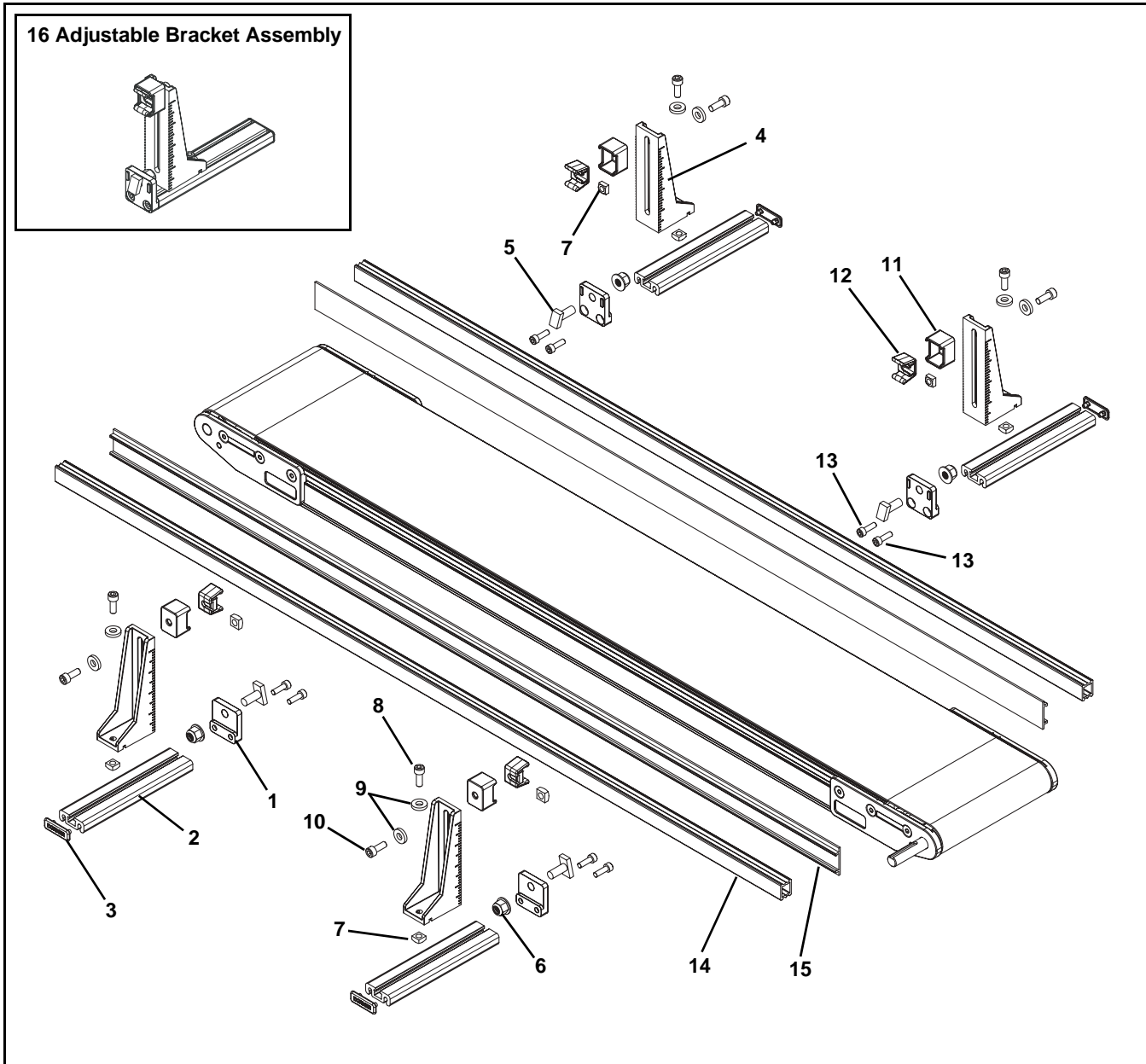

Item	Part Number	Description
1	210848	Mounting Block
2	210846-00600	Extrusion Base
3	210849	Cap
4	210847	Mounting Bracket
5	834-007	Stud, M8 x 20 mm
6	990812M	Hex Nut, M8-1.25
7	807-920	Square Nut, M6-1.0
8	920616M	Socket Head Screw, M6-1.00 x 16 mm
9	605279P	Washer
10	920622M	Socket Head Screw, M6-1.00 x 22 mm
11	206383	Guide Ring
12	206397	Clip
13	920516M	Socket Head Screw, M5-.80 x 16 mm

Item	Part Number	Description
14	834-238- <u>LLLLL</u>	Guide Rail
	GTB13A04	Guide Rail 4' long
	GTB13A08	Guide Rail 8' long
15	834-241	1.3" UHMW Guiding (per foot)
	GTB13B04	1.3" UHMW Guiding 4' long
	GTB13B08	1.3" UHMW Guiding 8' long
	206683	2" UHMW Guiding (per foot)
	GTB13C04	2" UHMW Guiding 4' long
	GTB13C08	2" UHMW Guiding 8' long
16	206193	Adjustable Bracket Assembly (Includes Items 1 through 13)
		<u>LLLLL</u> = part length in inches with 2 decimal places
		Length Example: Length = 35.25" <u>LLLLL</u> = 03525

#19, 39 & 49 Profile - Horizontal Adjustable Guiding

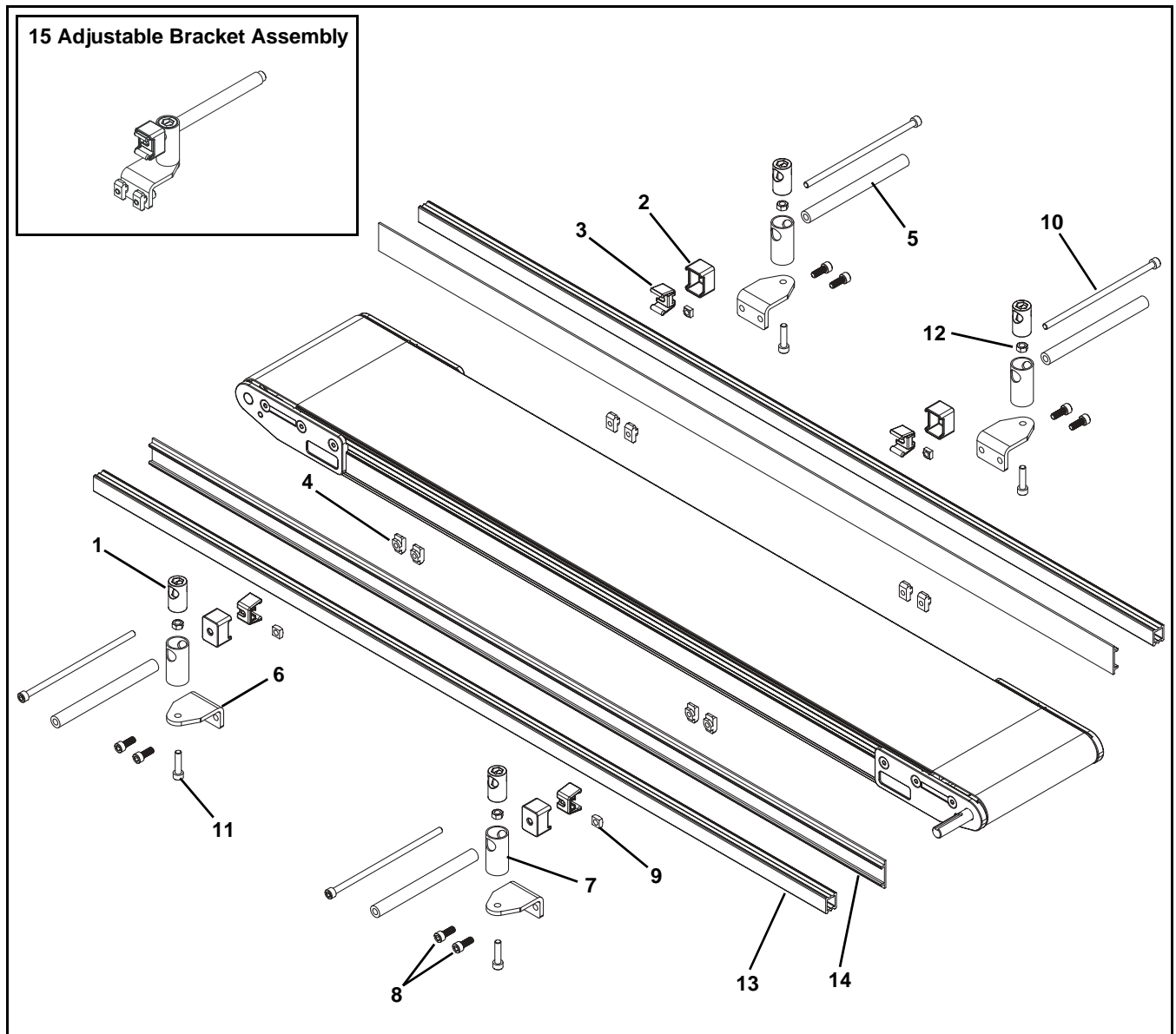

Item	Part Number	Description
1	206382	Insert Clamp
2	206383	Guide Ring
3	206397	Clip
4	206685	T-Nut
5	206692	Guide Tube
6	207146	Bracket
7	207147	Guide Tube
8	807-2859	Nylon Cap Screw, N6 x 16 mm
9	807-920	Square Nut, M6-1.0
10	9206150M	Socket Head Screw, M6-1.00 x 150 mm
11	920625M	Socket Head Screw, M6-1.00 x 25 mm
12	990601M	Hex Nut

Item	Part Number	Description
13	834-238-LLLLL	Guide Rail
	GTB13A04	Guide Rail 4' long
	GTB13A08	Guide Rail 8' long
14	834-241	1.3" UHMW Guiding (per foot)
	GTB13B04	1.3" UHMW Guiding 4' long
	GTB13B08	1.3" UHMW Guiding 8' long
	206683	2" UHMW Guiding (per foot)
	GTB13C04	2" UHMW Guiding 4' long
	GTB13C08	2" UHMW Guiding 8' long
15	207150	Adjustable Bracket Assembly (Includes Items 1 through 13)

LLLLL = part length in inches with 2 decimal places
 Length Example: Length = 35.25" LLLLL = 03525

Service Parts

#20, 40 & 50 Profile - Tool-Less Horizontal Adjustable Guiding

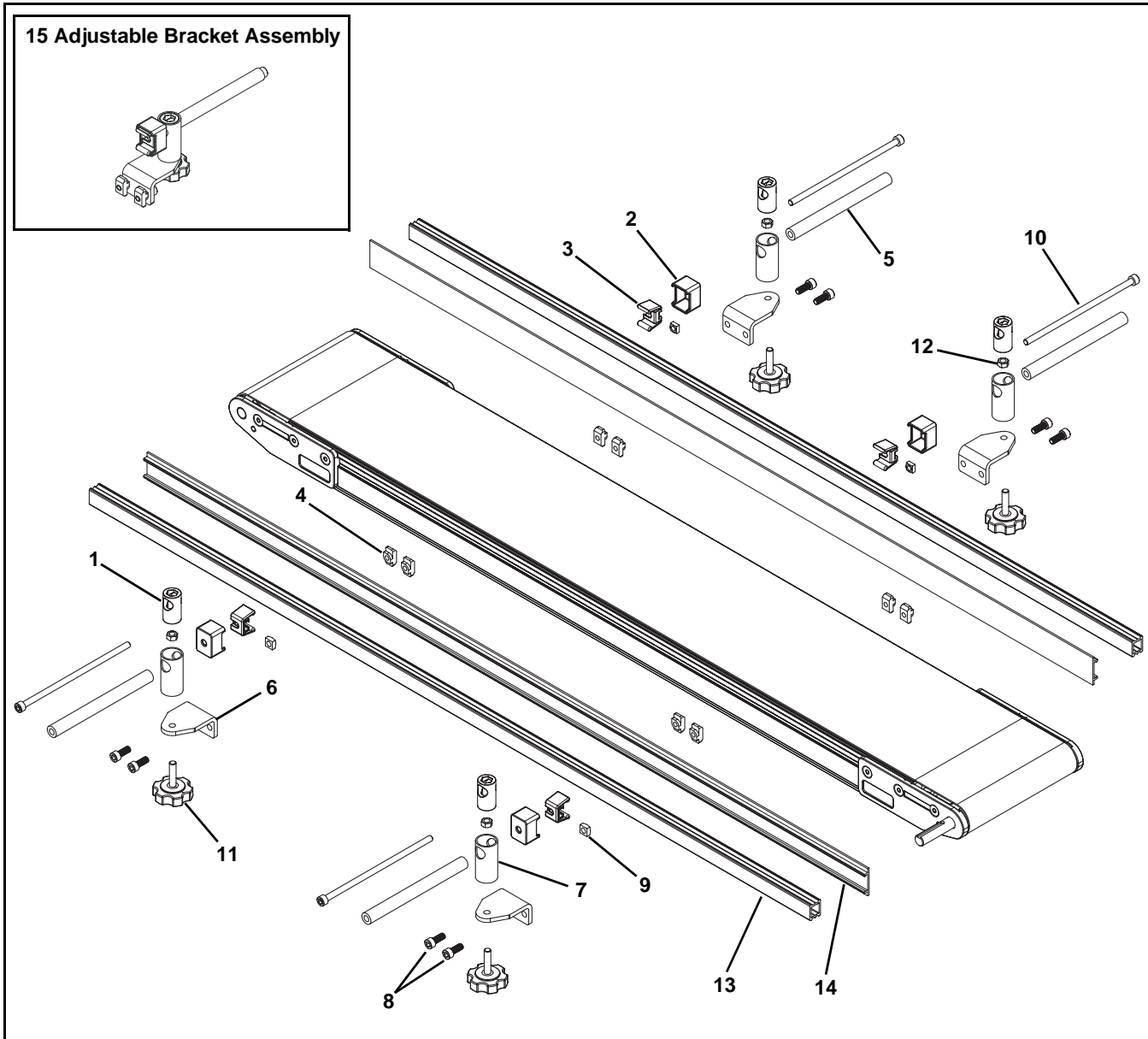

Item	Part Number	Description
1	206382	Insert Clamp
2	206383	Guide Ring
3	206397	Clip
4	206685	T-Nut
5	206692	Guide Tube
6	207146	Bracket
7	207147	Guide Tube
8	807-2859	Nylon Cap Screw, N6 x 16 mm
9	807-920	Square Nut, M6-1.0
10	9206150M	Socket Head Screw, M6-1.00 x 150 mm
11	207155	Knob
12	990601M	Hex Nut

Item	Part Number	Description
13	834-238-LLLLL	Guide Rail
	GTB13A04	Guide Rail 4' long
	GTB13A08	Guide Rail 8' long
14	834-241	1.3" UHMW Guiding (per foot)
	GTB13B04	1.3" UHMW Guiding 4' long
	GTB13B08	1.3" UHMW Guiding 8' long
	206683	2" UHMW Guiding (per foot)
	GTB13C04	2" UHMW Guiding 4' long
GTB13C08	2" UHMW Guiding 8' long	
15	207151	Tool-Less Adjustable Bracket Assembly (Includes Items 1 through 13)
		LLLLL = part length in inches with 2 decimal places
		Length Example: Length = 35.25" LLLLL = 03525

#2 Cleated Profile - 1.00" (25 mm) High Side

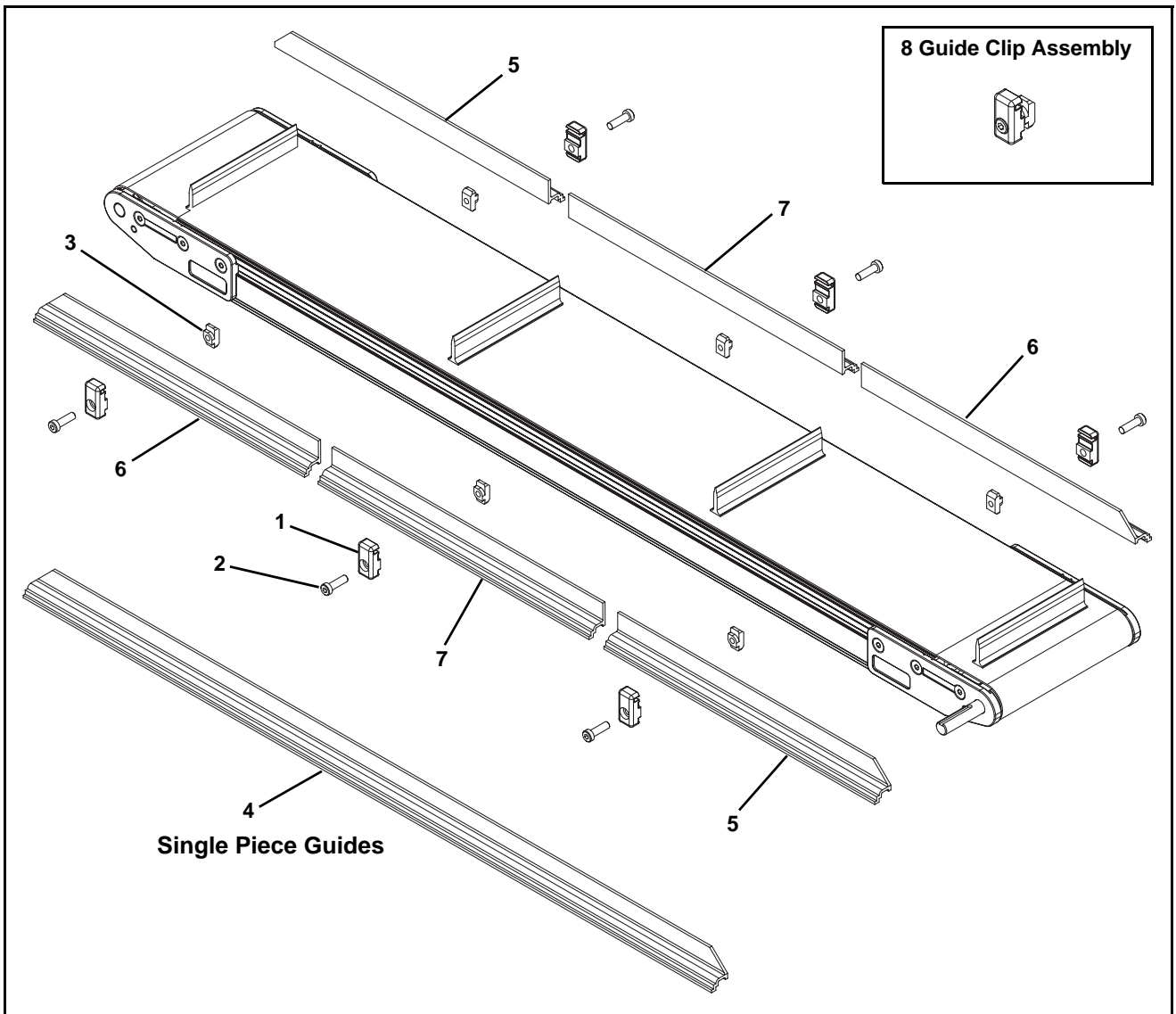

Item	Part Number	Description
1	206503	Guide Clip
2	807-2878	Low Head Cap Screw, M6-1.00 x 16 mm
3	206685	T-Nut
4	280203- <u>LLLLL</u>	1.00" Cleated Guiding for Single Piece Guides
5	280202- <u>LLLLL</u>	1.00" End 1 Section Cleated Guiding for Multi Piece Guides
6	280201- <u>LLLLL</u>	1.00" End 2 Section Cleated Guiding for Multi Piece Guides
7	206515- <u>LLLLL</u>	1.00" Mid Section Cleated Guiding for Multi Piece Guides
8	203661	Guide Clip Assembly (Includes items 1, 2, and 3)
<u>LLLLL</u> = part length in inches with 2 decimal places		
Length Example: Length = 35.25" <u>LLLLL</u> = 03525		

Service Parts

#4 Cleated Profile - 1.00" (25 mm) High Side (Non-Reversing)

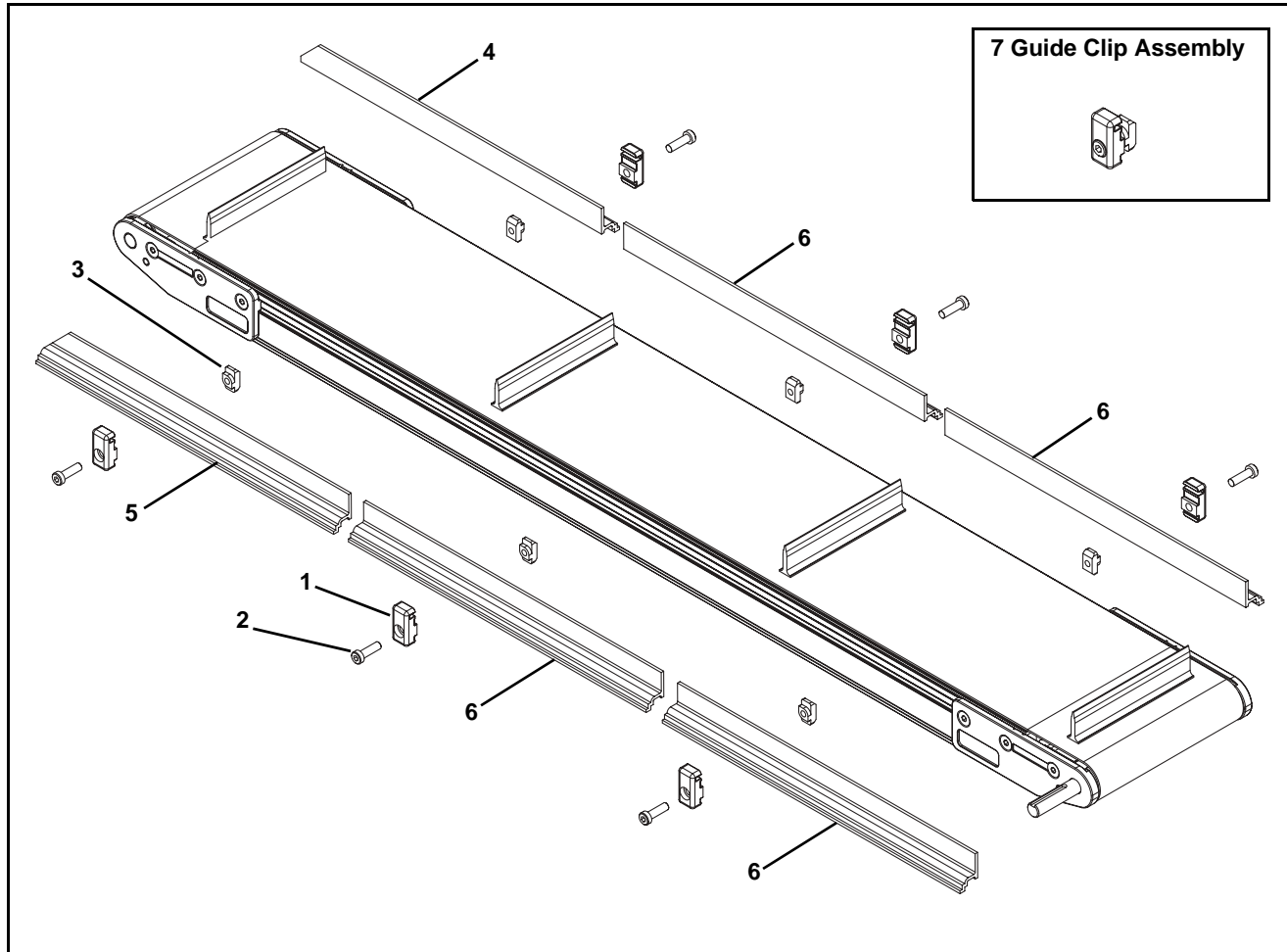

Item	Part Number	Description
1	206503	Guide Clip
2	807-2878	Low Head Cap Screw, M6-1.00 x 16 mm
3	206685	T-Nut
4	280202- <u>LLLLL</u>	1.00" End 1 Section Cleated Guiding for Multi Piece Guides
5	280201- <u>LLLLL</u>	1.00" End 2 Section Cleated Guiding for Multi Piece Guides
6	206515- <u>LLLLL</u>	1.00" Mid Section Cleated Guiding for Multi Piece Guides
7	203661	Guide Clip Assembly (Includes items 1, 2, and 3)
<u>LLLLL</u> = part length in inches with 2 decimal places		
Length Example: Length = 35.25" <u>LLLLL</u> = 03525		

#3 Cleated Profile - 2.50" (64 mm) High Side

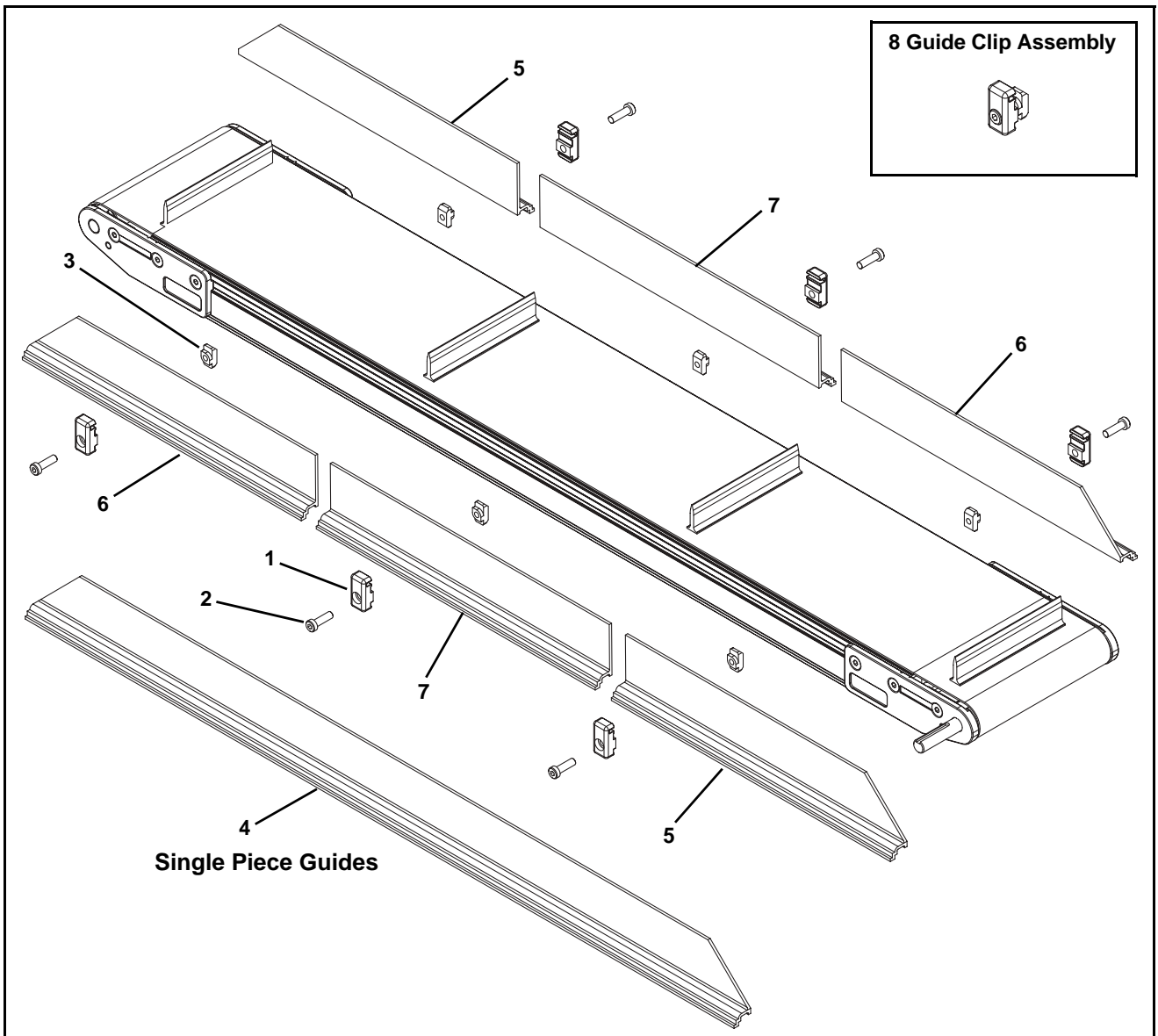

Item	Part Number	Description
1	206503	Guide Clip
2	807-2878	Low Head Cap Screw, M6-1.00 x 16 mm
3	206685	T-Nut
4	280303-LLLLL	2.50" Cleated Guiding for Single Piece Guides
5	280302-LLLLL	2.50" End 1 Section Cleated Guiding for Multi Piece Guides
6	280301-LLLLL	2.50" End 2 Section Cleated Guiding for Multi Piece Guides
7	206516-LLLLL	2.50" Mid Section Cleated Guiding for Multi Piece Guides
8	203661	Guide Clip Assembly (Includes items 1, 2, and 3)
LLLLL = part length in inches with 2 decimal places		
Length Example: Length = 35.25" LLLLL = 03525		

Service Parts

#5 Cleated Profile - 2.50" (64 mm) High Side (Non-Reversing)

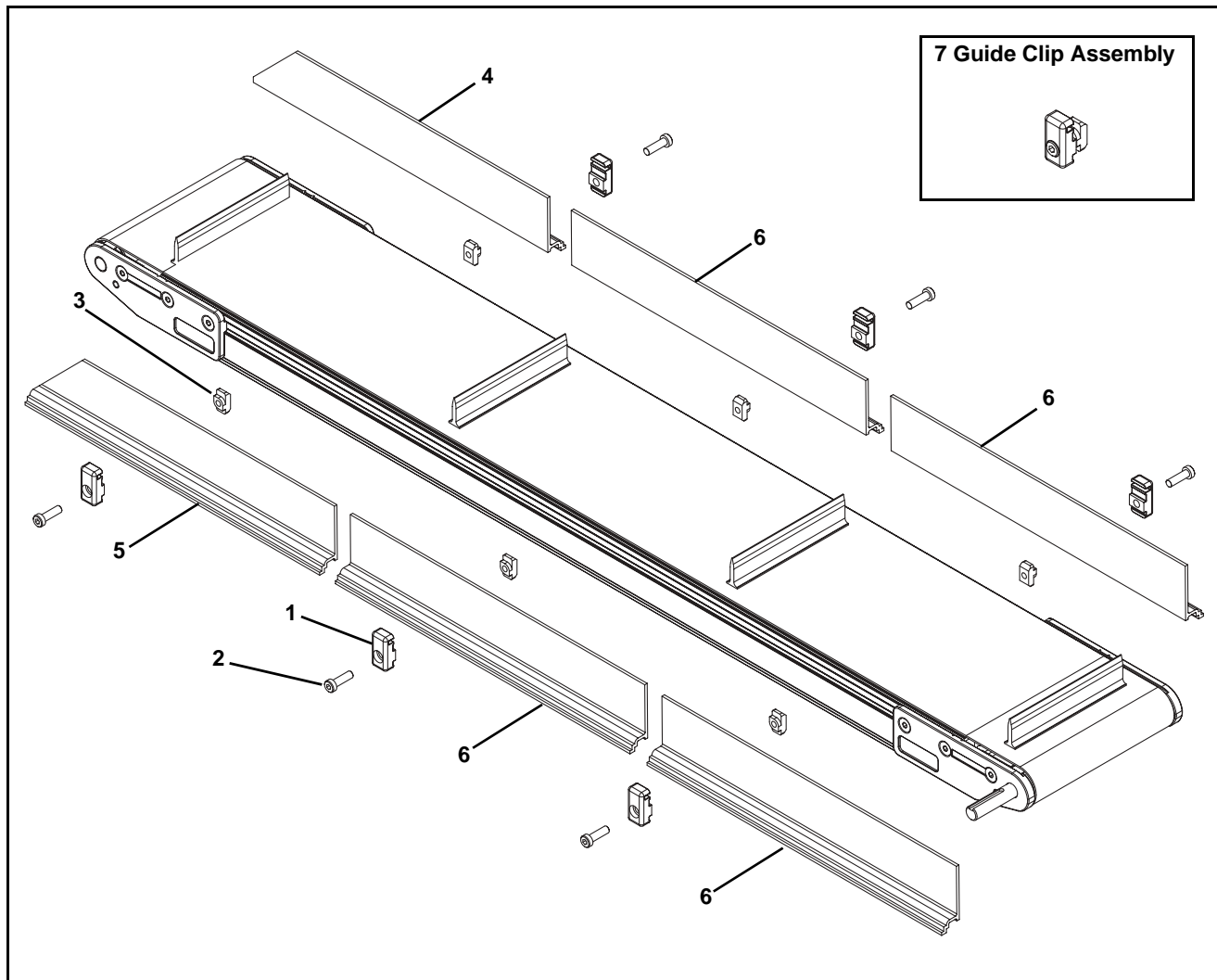

Item	Part Number	Description
1	206503	Guide Clip
2	807-2878	Low Head Cap Screw, M6-1.00 x 16 mm
3	206685	T-Nut
4	280302-LLLLL	2.50" End 1 Section Cleated Guiding for Multi Piece Guides
5	280301-LLLLL	2.50" End 2 Section Cleated Guiding for Multi Piece Guides
6	206516-LLLLL	2.50" Mid Section Cleated Guiding for Multi Piece Guides
7	203661	Guide Clip Assembly (Includes items 1, 2, and 3)
LLLLL = part length in inches with 2 decimal places		
Length Example: Length = 35.25" LLLLL = 03525		

#3 Cleated LPZ Profile - 2.50" (64 mm) High Side

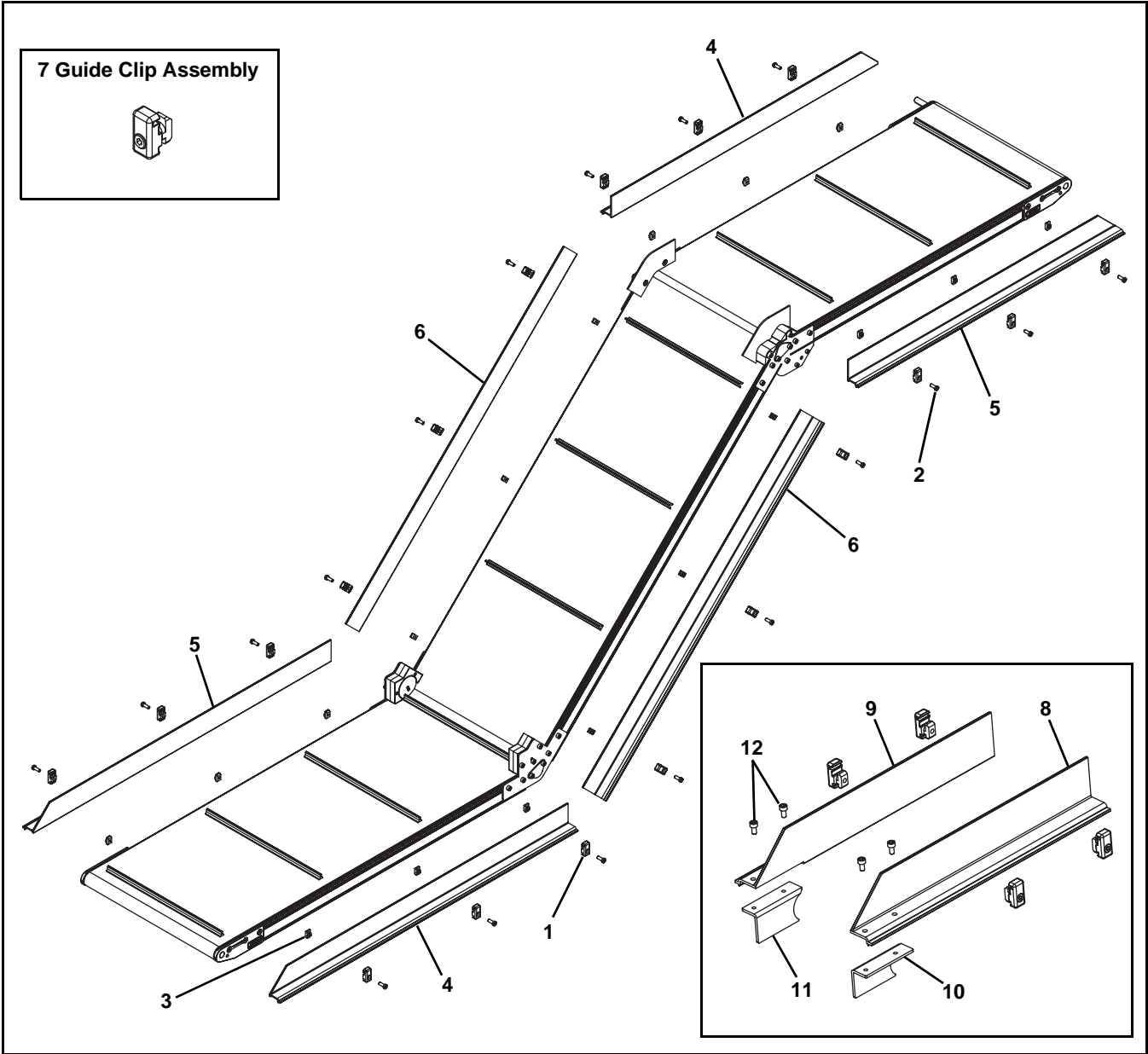

Item	Part Number	Description
1	206503	Guide Clip
2	807-2878	Low Head Cap Screw, M6-1.00 x 16 mm
3	206685	T-Nut
4	280101-LLLLL	2.50" End 1 Section Cleated Guiding
5	280102-LLLLL	2.50" End 2 Section Cleated Guiding
6	206517-LLLLL	2.50" Mid Section Cleated Guiding
7	203661	Guide Clip Assembly (Includes items 1, 2, and 3)
8	207228	Guide for End 1 Section Horizontal to Incline Conveyors

Item	Part Number	Description
9	207227	Guide for End 2 Section Horizontal to Incline Conveyors
10	207230	Exit Guide for End 1 Section Horizontal to Incline Conveyors
11	207229	Exit Guide for End 2 Section Horizontal to Incline Conveyors
12	920510M	Socket Head Screw, M5-.80 x 10 mm
LLLLL = part length in inches with 2 decimal places		
Length Example: Length = 35.25" LLLLL = 03525		

Service Parts

#5 Cleated LPZ Profile - 2.50" (64 mm) High Side (Non-Reversing)

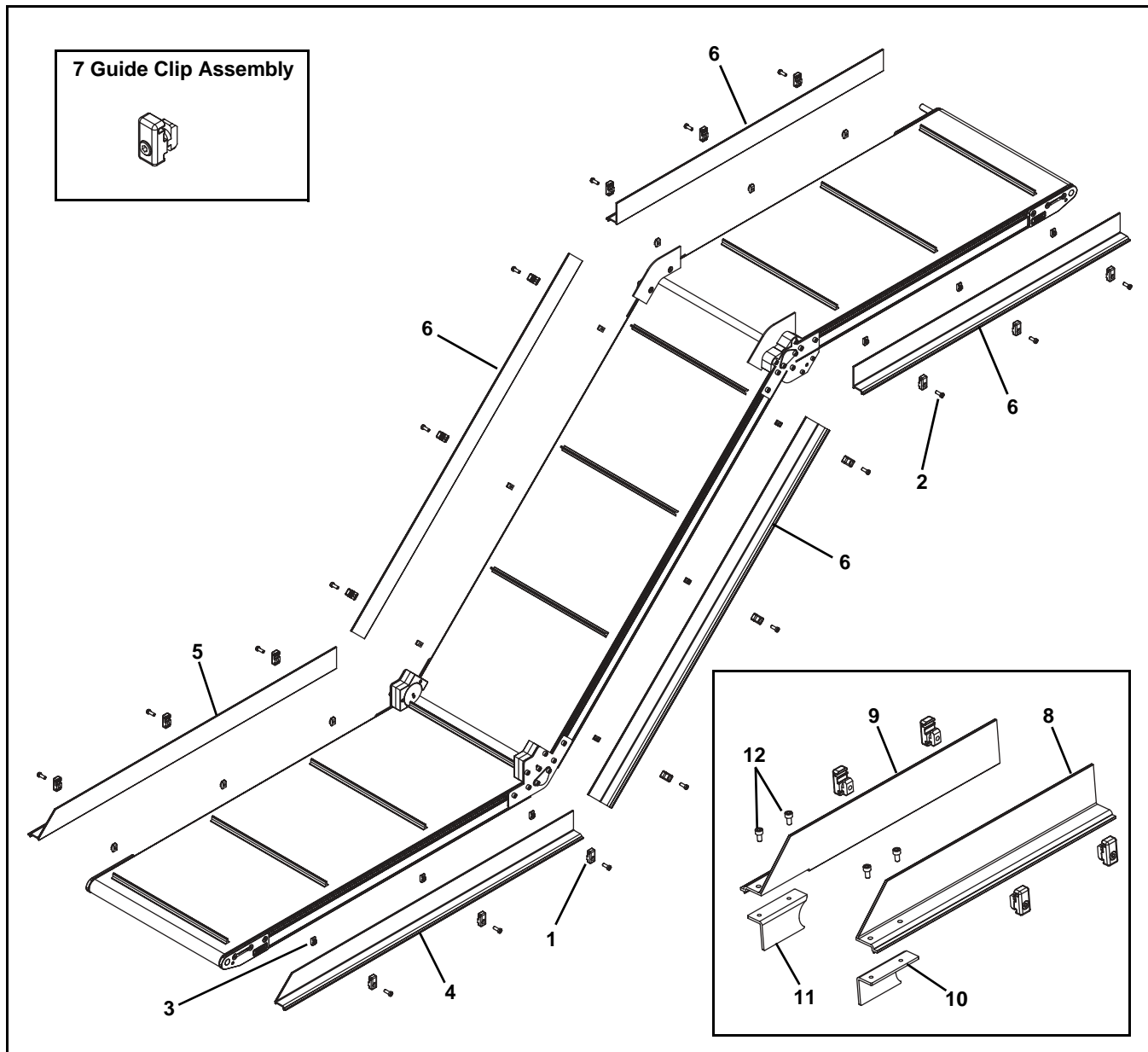

Item	Part Number	Description
1	206503	Guide Clip
2	807-2878	Low Head Cap Screw, M6-1.00 x 16 mm
3	206685	T-Nut
4	280101-LLLLL	2.50" End 1 Section Cleated Guiding
5	280102-LLLLL	2.50" End 2 Section Cleated Guiding
6	206517-LLLLL	2.50" Mid Section Cleated Guiding
7	203661	Guide Clip Assembly (Includes items 1, 2, and 3)
8	207228	Guide for End 1 Section Horizontal to Incline Conveyors

Item	Part Number	Description
9	207227	Guide for End 2 Section Horizontal to Incline Conveyors
10	207230	Exit Guide for End 1 Section Horizontal to Incline Conveyors
11	207229	Exit Guide for End 2 Section Horizontal to Incline Conveyors
12	920510M	Socket Head Screw, M5-.80 x 10 mm
LLLLL = part length in inches with 2 decimal places		
Length Example: Length = 35.25" LLLLL = 03525		

Flat Belt Mounting Brackets

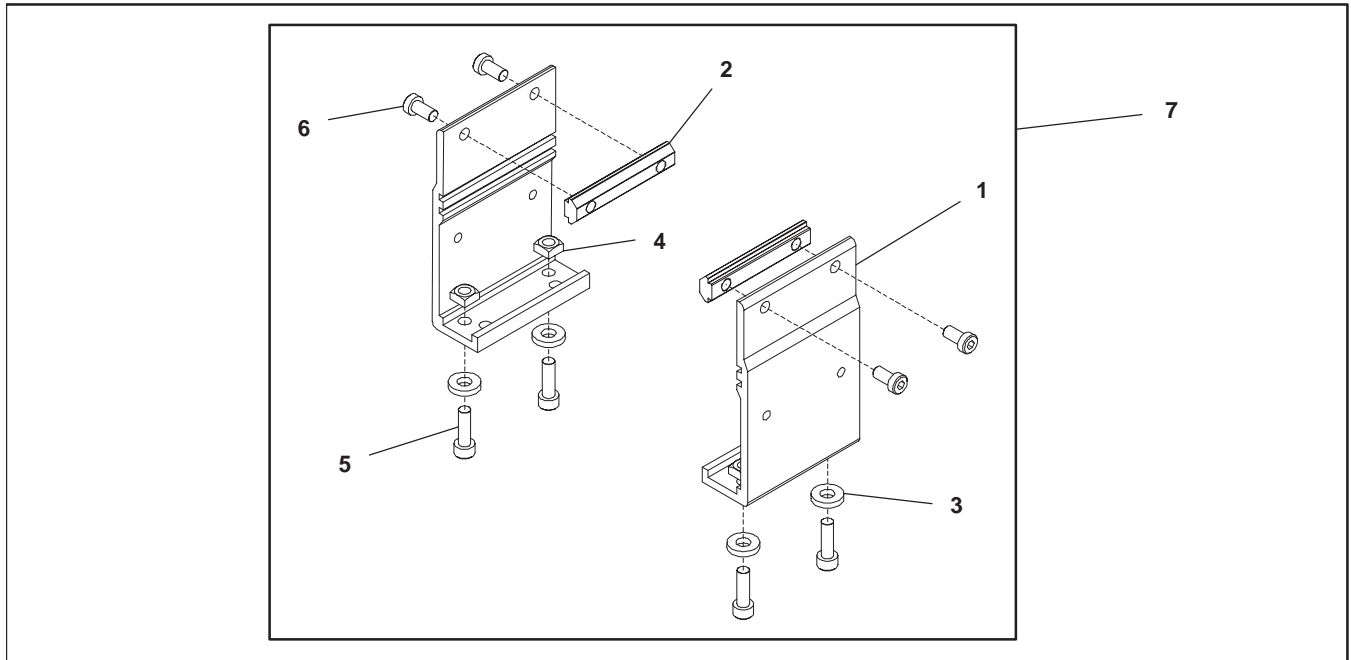

Item	Part Number	Description
1	240831	Stand Mount
2	300150MK4	Drop-In Tee Bar (x4)
3	605279P	Washer
4	807-920	Square Nut M6

Item	Part Number	Description
5	920620M	Socket Head Screw M6 x 20 mm
6	950616M	Low Head Cap Screw M6 x 16 mm
7	240839	Flat Belt Stand Mount Assembly

Cleated Belt Mounting Brackets

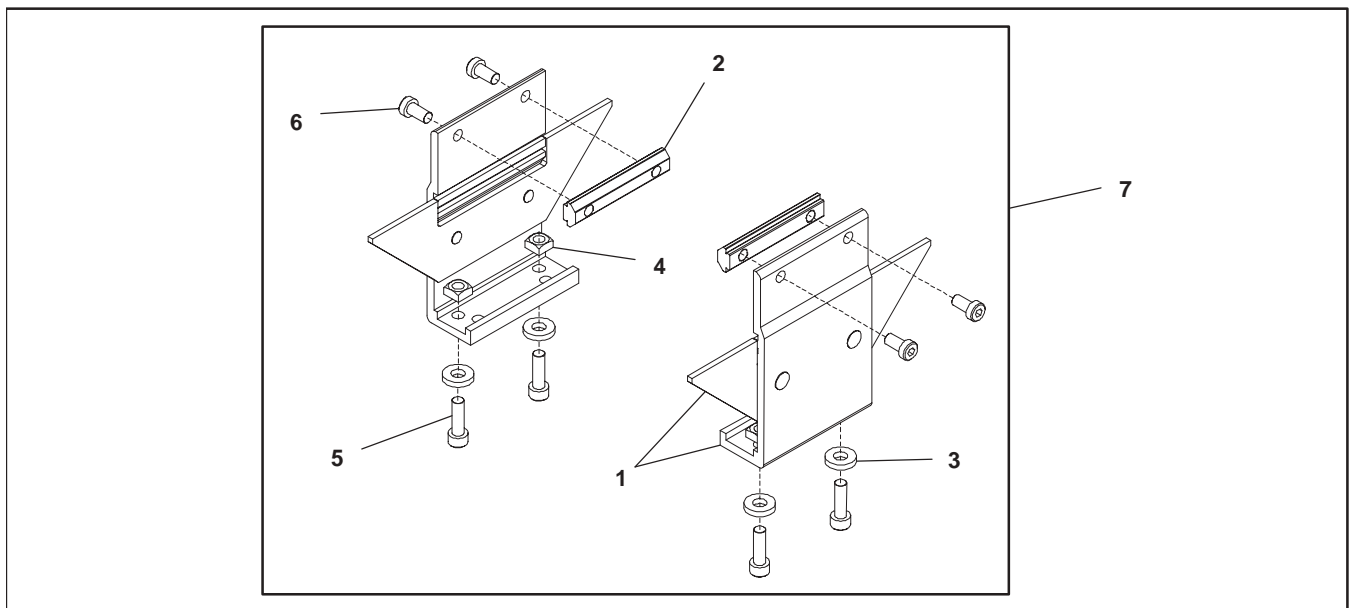

Item	Part Number	Description
1	240836	Cleated Mount Assembly
2	300150MK4	Drop-In Tee Bar (x4)
3	605279P	Washer

Item	Part Number	Description
4	807-920	Square Nut M6
5	920620M	Socket Head Screw M6 x 20 mm
6	950616M	Low Head Cap Screw M6x16 mm
7	240838	Cleated Stand Mount Assembly

Service Parts

Flat Belt Mounting Brackets for Short Conveyors

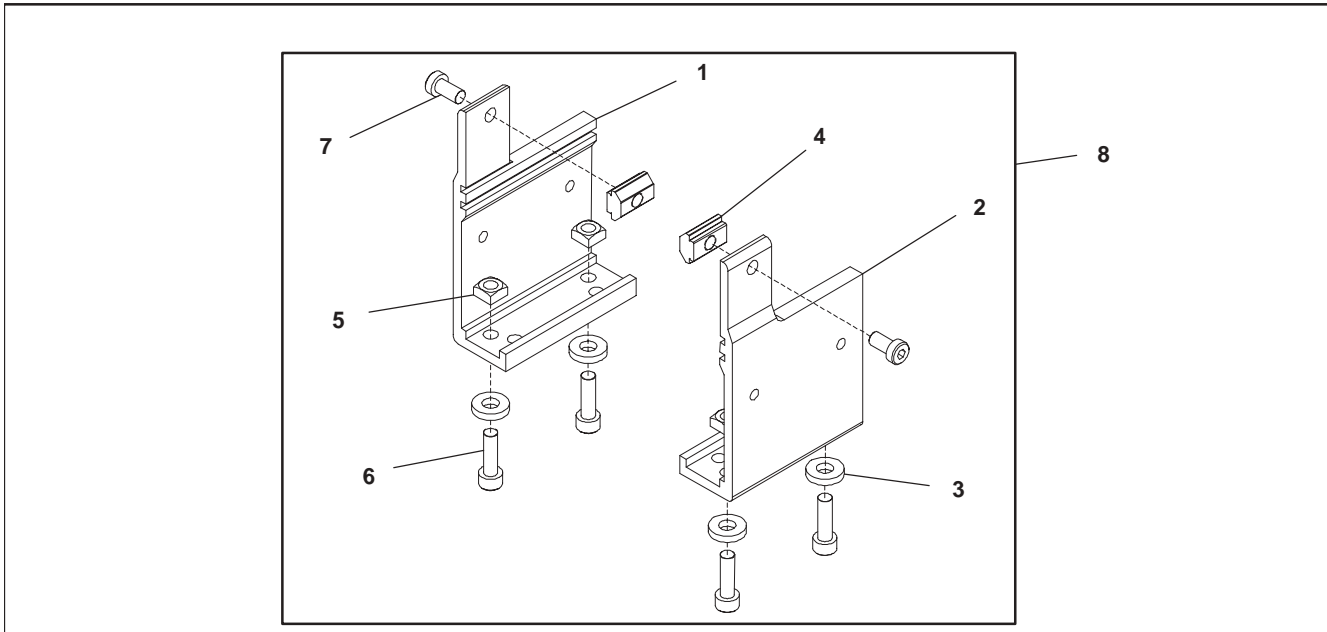

Item	Part Number	Description
1	240833	Stand Mount, LH 2' (610mm)
2	240834	Stand Mount, RH 2' (610mm)
3	605279P	Washer
4	639971MK10	Drop-In Tee Bar (x10)

Item	Part Number	Description
5	807-920	Square Nut M6
6	920620M	Socket Head Screw M6 x 20 mm
7	950616M	Low Head Cap Screw M6 x 16 mm
8	240847	Flat Belt Stand Mount Assembly for 2' (610mm) Conveyors

Cleated Belt Mounting Brackets for Short Conveyors

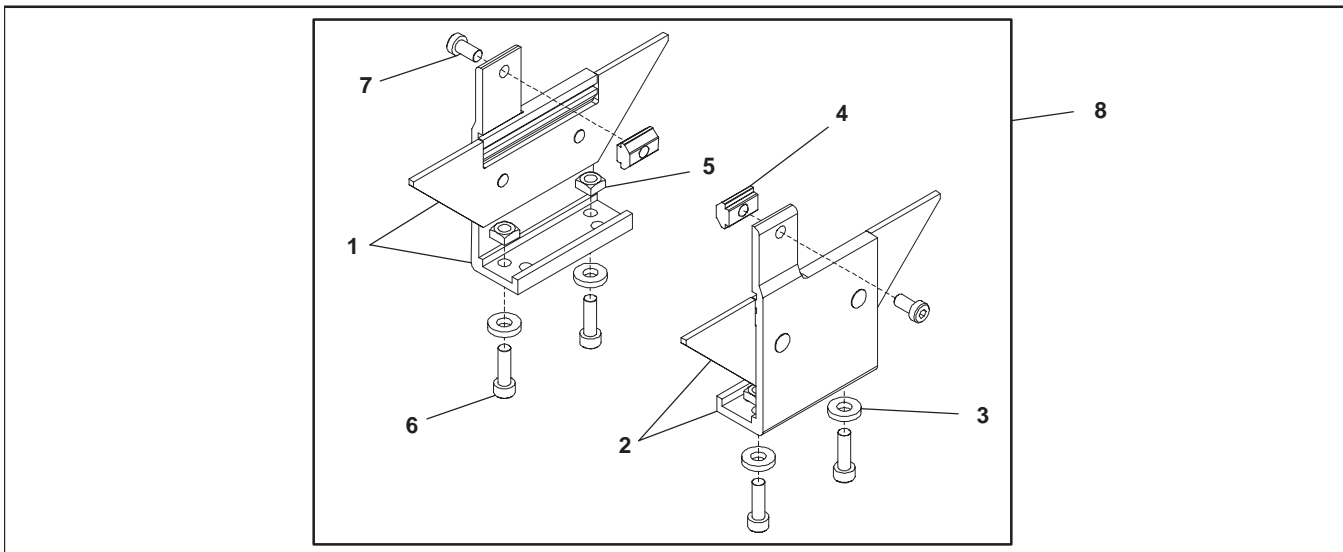

Item	Part Number	Description
1	240852	Cleated Stand Bracket Assembly LH 2' (610mm) Conveyor
2	240853	Cleated Stand Bracket Assembly RH 2' (610mm) Conveyor
3	605279P	Washer
4	639971MK10	Drop-In Tee Bar (x10)

Item	Part Number	Description
5	807-920	Square Nut M6
6	920620M	Socket Head Screw M6 x 20 mm
7	950616M	Low Head Cap Screw M6 x 16 mm
8	240851	Cleated Belt Stand Mount Assembly for 2' (610mm) Conveyors

Flat Belt Mounting Brackets Assembled to the Tail

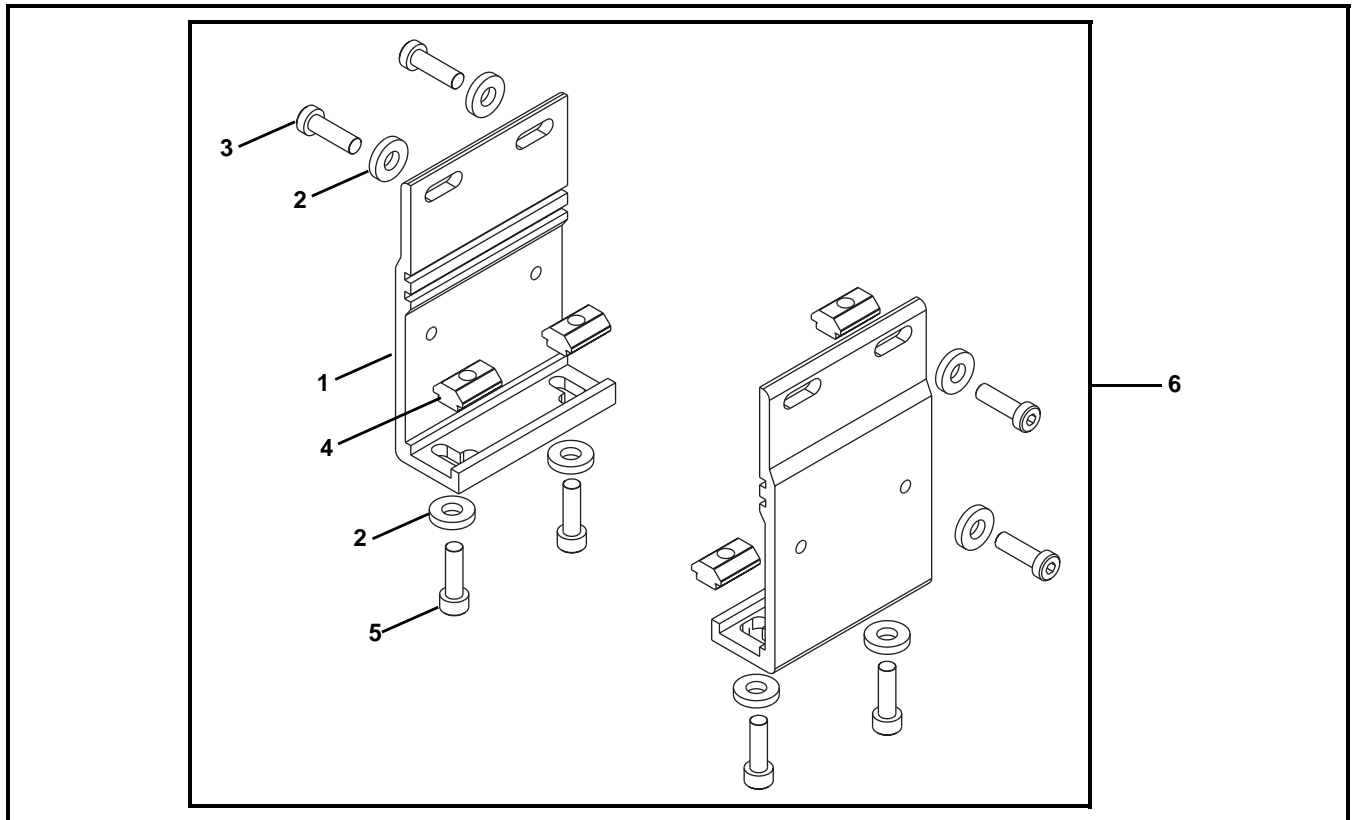

Item	Part Number	Description
1	240850	Stand Mount
2	605279P	Washer
3	950620M	Socket Low Head Screw M6 x 20 mm

Item	Part Number	Description
4	639971MK10	Drop-In Tee Bar (x10)
5	920620M	Socket Head Screw M6 x 20 mm
6	240854	Flat Belt Stand Mount Assembly for Tail Mounts

Connecting Assembly without Stand Mount

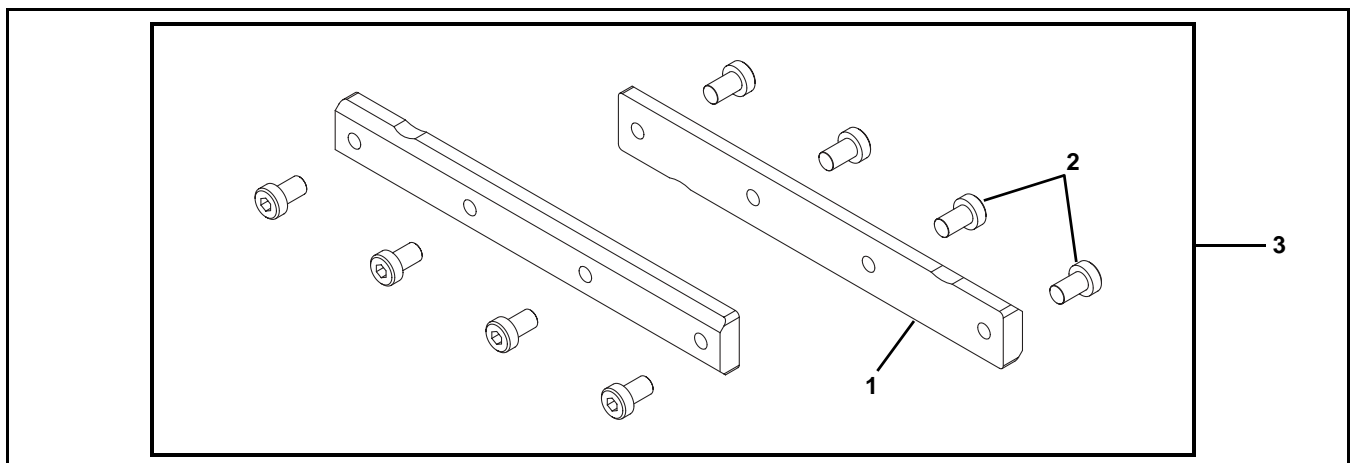

Item	Part Number	Description
1	206520	Connecting Bar
2	950610M	Low Head Cap Screw, M6-1.00 x 10 mm
3	206519	Connecting Assembly

Service Parts

Flat Belt Connecting Assembly with Stand Mount

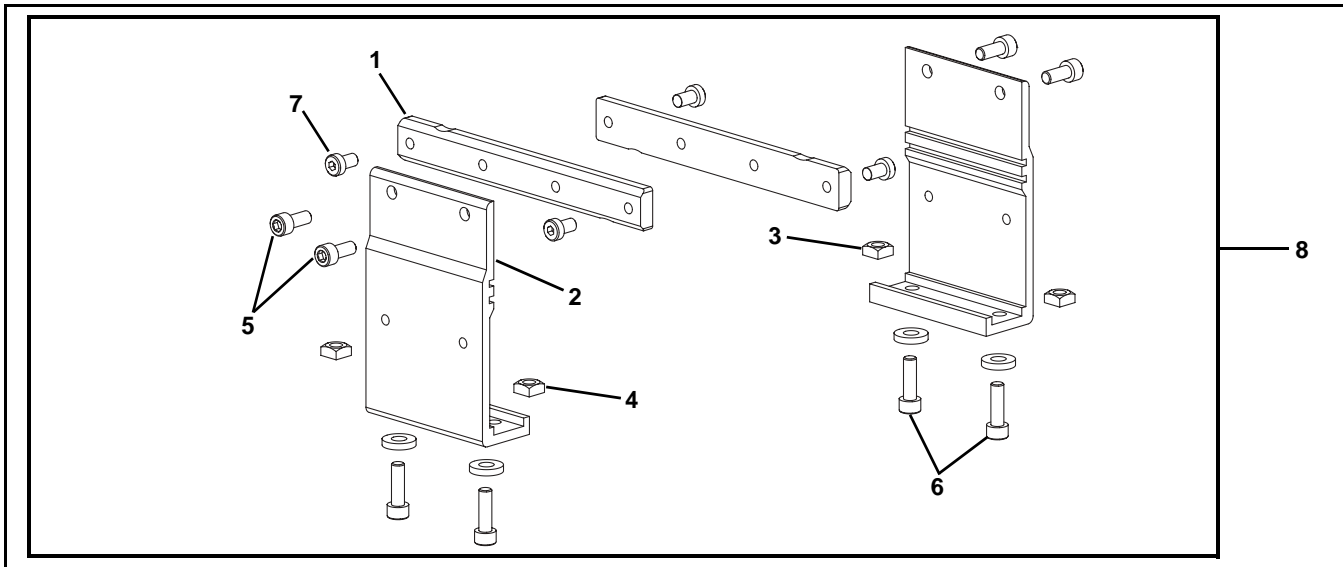

Item	Part Number	Description
1	206520	Connecting Bar
2	240831	Stand Mount
3	605279P	Washer
4	807-920	Square Nut M6

Item	Part Number	Description
5	920614M	Socket Head Screw, M6-1.00 x 14 mm
6	920620M	Socket Head Screw, M6-1.00 x 20 mm
7	950610M	Low Head Cap Screw, M6-1.00 x 10 mm
8	206518	Connecting Assembly

Cleated Belt Connecting Assembly with Stand Mount

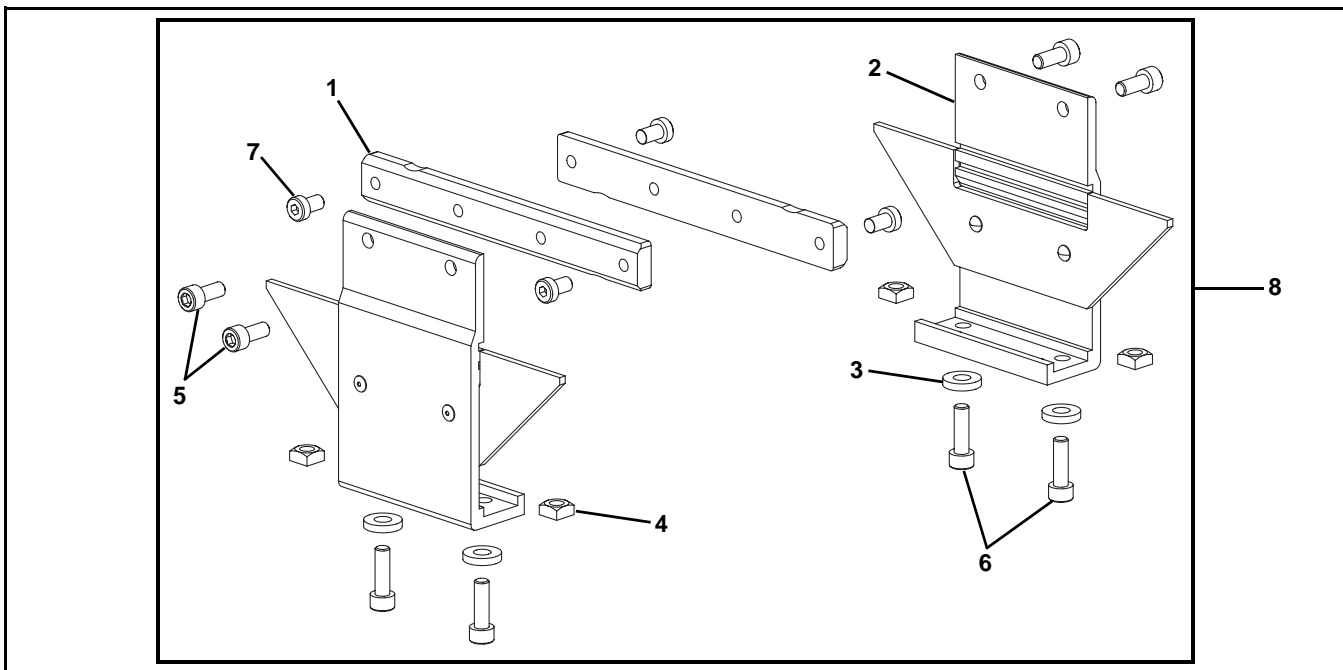

Item	Part Number	Description
1	206520	Connecting Bar
2	240836	Cleated Stand Mount Assembly
3	605279P	Washer
4	807-920	Square Nut M6

Item	Part Number	Description
5	920614M	Socket Head Screw, M6-1.00 x 14 mm
6	920620M	Socket Head Screw, M6-1.00 x 20 mm
7	950610M	Low Head Cap Screw, M6-1.00 x 10 mm
8	240929	Connecting Assembly

2" (51 mm) to 6" (152 mm) Flat Belt Return Roller

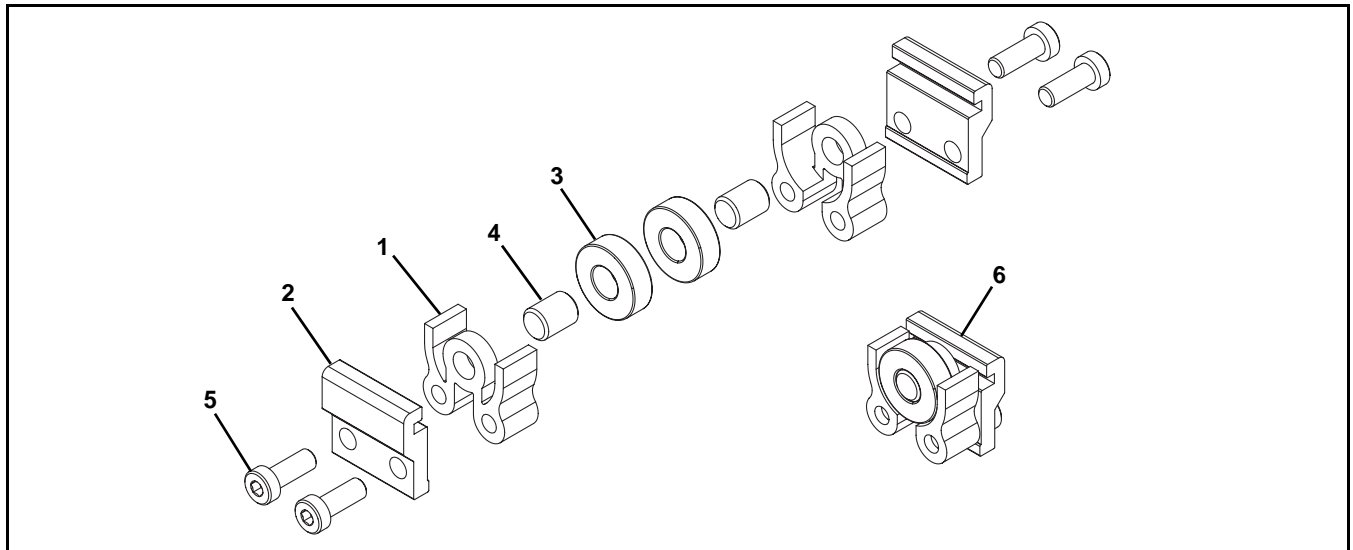

Item	Part Number	Description
1	240825	Return Roller Guard – Short
2	205978	Flat Return Roller Clip
3	802-027	Bearing
4	913-100	Dowel Pin

Item	Part Number	Description
5	950616M	Low Head Cap Screw M6-1.00 x 16 mm
6	206522	Return Roller Assembly

8" (203 mm) to 24" (610 mm) Flat Belt Return Roller

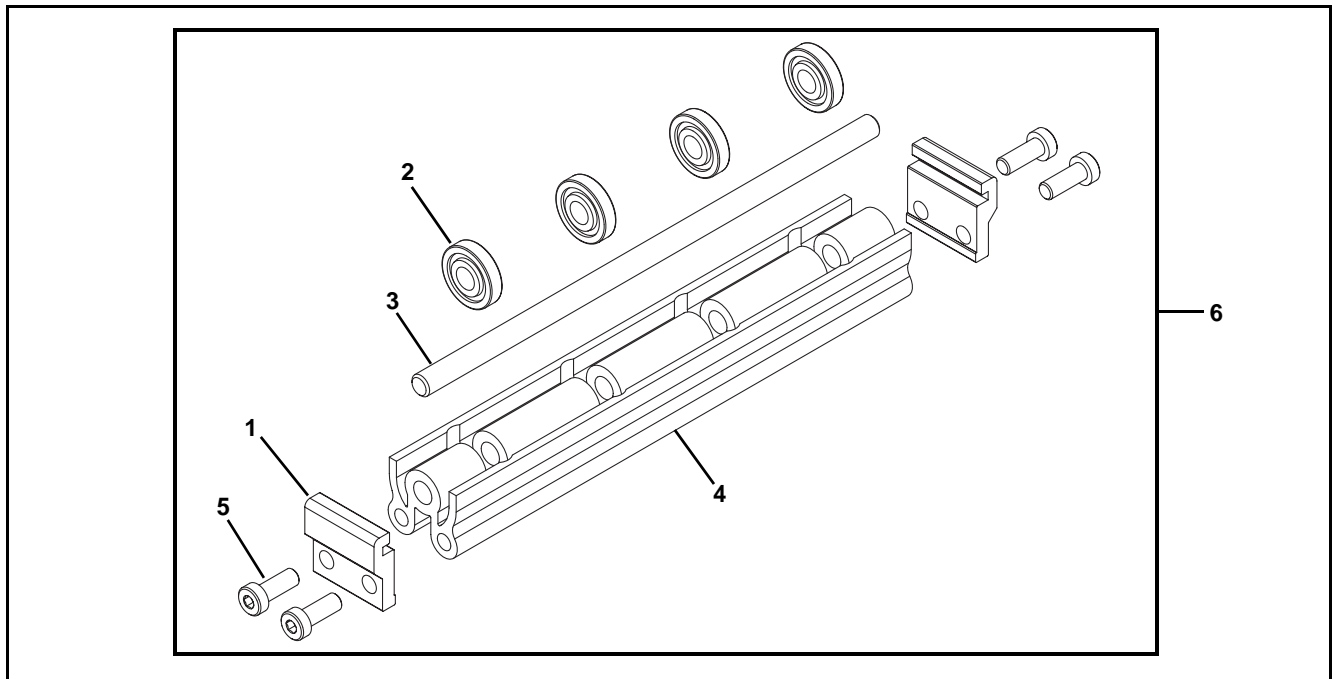

Item	Part Number	Description
1	205978	Flat Return Roller Clip
2	240826	Return Roller
3	2410 WW	Return Roller Rod
4	2436 WW	Return Roller Guard

Item	Part Number	Description
5	950616M	Low Head Cap Screw, M6-1.00 x 16 mm
6	206523- WW	Return Roller Assembly
WW = Conveyor width reference: 08, 10, 12, 14, 16, 18, 20, 22, & 24		

Service Parts

Cleated Belt Return Roller

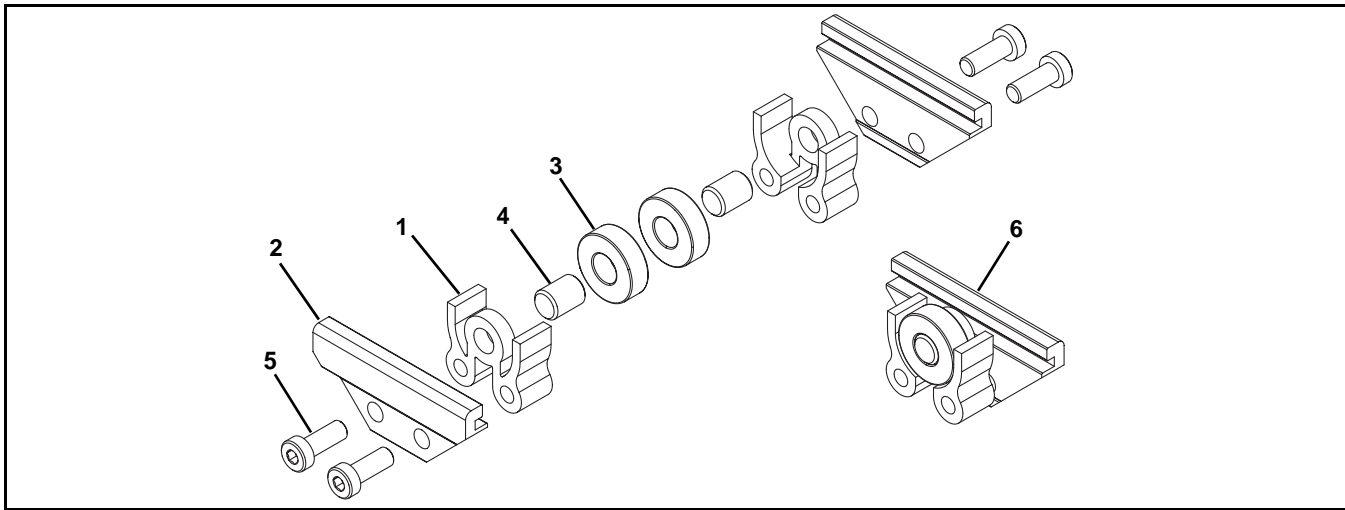

Item	Part Number	Description
1	240825	Return Roller Guard – Short
2	205979	Cleated Return Roller Clip
3	802-027	Bearing
4	913-100	Dowel Pin

Item	Part Number	Description
5	950616M	Low Head Cap Screw M6-1.00 x 16 mm
6	206521	Cleated Belt Return Roller Assembly

Photo Eye

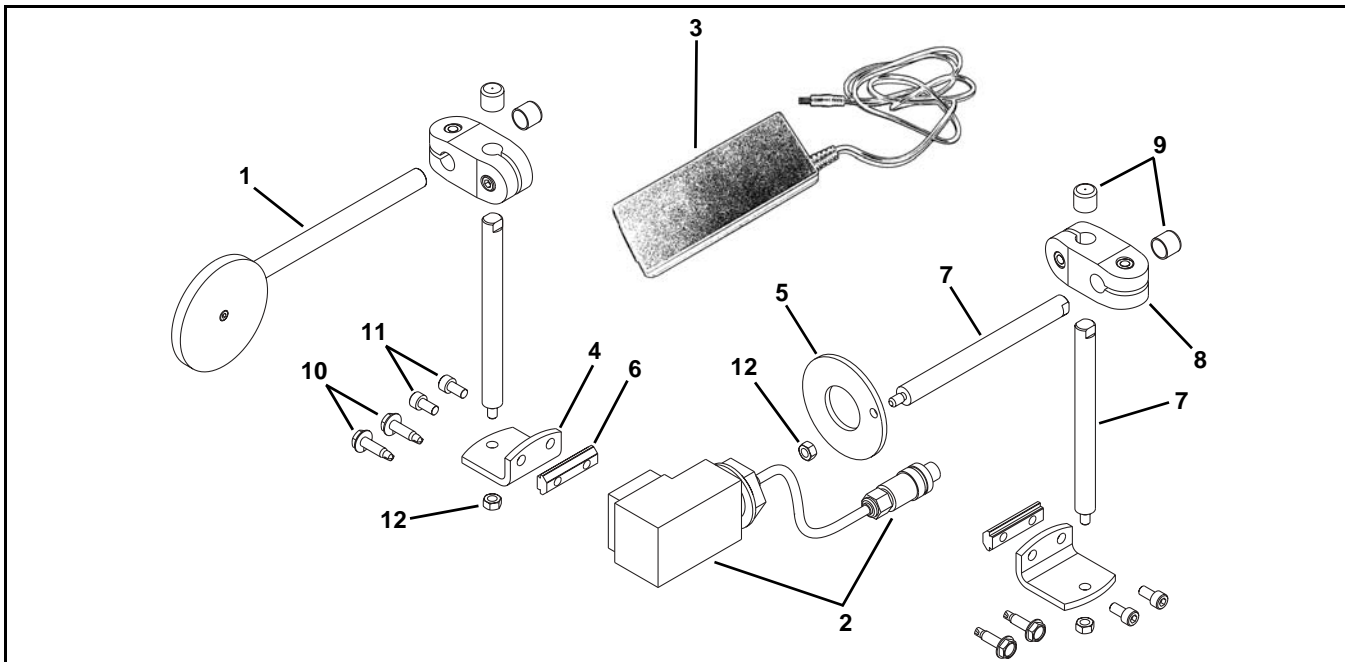

Item	Part Number	Description
1	201880	Reflector Mounting Assembly
2	201881	Eye Assembly with Plug
3	201882	Transformer with Plug
4	202004	Mounting Bracket
5	205109	Washer
6	200830M	Drop-In Tee Bar

Item	Part Number	Description
7	202028M	Mounting Shaft
8	807-652	Cross Block
9	807-948	Cap
10	807-1937	Drilling Screw, 1/4-20 x 1" (2300 Series)
11	920612M	Socket Head Screw, M6-1.00 x 12 mm (2200 Series)
12	990601M	Hex Nut

Conveyor Belt Part Number Configuration

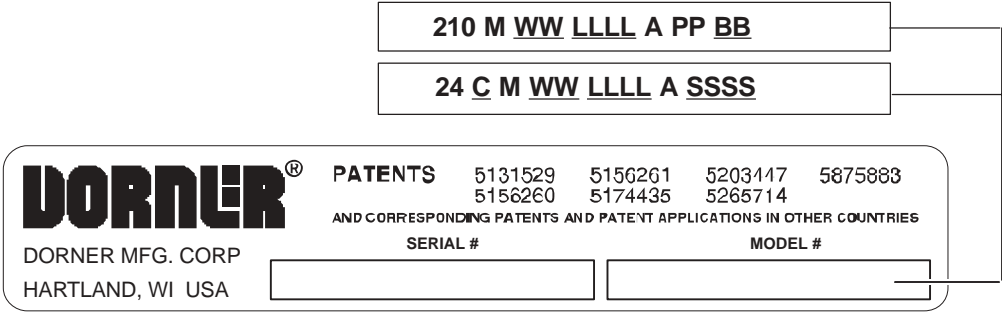

Figure 154

Flat Belt Part Number Configuration

Refer to Dorner patent plate (Figure 154). From the model number, determine conveyor width (“WW”), length (“LLLL”) and belt type (“BB”). Use data to configure belt part number as indicated below. *Add “V” for V-guided belts.

22 - WW LLLL / BB V *

22 - _____ / _____ V*

(Fill In)

Cleated Belt Part Number Configuration

Refer to Dorner patent plate (Figure 154). From the model number, determine conveyor type (“T”), width (“WW”), length (“LLLL”), cleat type (“C”) and cleat spacing (“SSSS”). Use data to configure belt part number as indicated below. *Add “V” for V-guided belts.

2T - WW LLLL C SSSS V *

2 - _____ / _____ V*

(Fill In)

Return Policy

Returns must have prior written factory authorization or they will not be accepted. Items that are returned to Dorner without authorization will not be credited nor returned to the original sender. When calling for authorization, please have the following information ready for the Dorner factory representative or your local distributor:

1. Name and address of customer.
2. Dorner part number(s) of item(s) being returned.
3. Reason for return.
4. Customer's original order number used when ordering the item(s).
5. Dorner or distributor invoice number. Include part serial number if available.

A representative will discuss action to be taken on the returned items and provide a Returned Materials Authorization (RMA) number for reference. RMA will automatically close 30 days after being issued. To get credit, items must be new and undamaged. There will be a return charge on all items returned for credit, where Dorner was not at fault. It is the customer's responsibility to prevent damage during return shipping. Damaged or modified items will not be accepted. The customer is responsible for return freight.

Product Line	Product Type								Engineered to order parts
	Standard Products								
	Conveyors	Gearmotors & Mounting Packages	Support Stands	Accessories	Spare Parts (non-belt)	Spare Belts - Standard Flat Fabric	Spare Belts - Cleated & Spec. Fabric	Spare Belts - Plastic Chain	All equipment and parts
1100 Series	30% return fee for all products except: 50% return fee for conveyors with modular belt, cleated belt or speciality belts All Electrical items are assigned original manufacturers return policy.						non-returnable		case-by-case
2200 Series									
3200 Series									
Pallet Systems									
FlexMove/SmartFlex									
GAL Series									
All Electrical									
7100 Series	50% return fee for all products						non-returnable		case-by-case
7200/7300 Series									
AquaGard 7350 Series Version 2									
GES Series									
AquaGard 7350/7360 Series	non-returnable								
AquaPruf Series	non-returnable								

Returns will not be accepted after 60 days from original invoice date. The return charge covers inspection, cleaning, disassembly, disposal and reissuing of components to inventory. If a replacement is needed prior to evaluation of returned item, a purchase order must be issued. Credit (if any) is issued only after return and evaluation is complete.

Dorner has representatives throughout the world. Contact Dorner for the name of your local representative. Our Customer Service Team will gladly help with your questions on Dorner products.

For a copy of Dorner's Warranty, contact Dorner, an authorized sales channel or visit our website: www.dorner.com.

For replacement parts, contact an authorized Dorner Service Center or the factory.

www.dorner.com



© Dorner Mfg. Corp. 2018. All Rights Reserved.

Dorner – North & South America

Dorner – U.S.A.

Headquarters
 975 Cottonwood Ave
 Hartland, WI 53029, USA
 (800) 397-8664
 (262) 367-7600
info@dorner.com

Dorner – Canada

100-5515 North Service Road
 Burlington, Ontario L7L 6G6
 Canada
 (289) 208-7306
info@dorner.com

Dorner – Latin America

Carretera a Nogales #5297, Nave 11.
 Parque Industrial Nogales
 Zapopan, Jalisco C.P. 45222 México
 +52.33.30037400 | info.latinamerica@dorner.com

Dorner – Europe

Karl-Heinz-Beckurts-Straße 7
 52428 Jülich, Germany
 +49 (0) 2461/93767-0 | info.europe@dorner.com

Dorner – Asia

128 Jalan Permatang Damar Laut, Bayan Lepas 11960
 Penang, Malaysia
 +604-626-2948 | info.asia@dorner.com