

# ENGINEERING MANUAL

Superior V-Guided  
Belt Tracking

Universal Motor &  
Mounting Package

Fast & Simple to Use  
Online Configurator

Industry-Best  
Product Transfers



**2200 LOW PROFILE**  
**2200 PRECISION MOVE**  
**2700 MEDIUM DUTY**

**DORNER**<sup>®</sup>

By Columbus McKinnon

# 2200/2700 SERIES

## INDUSTRY LEADING TECHNOLOGY



### 2200 Low Profile

- 32 mm (1.25 in) roller diameter, widths from 44 mm (1.75 in) to 610 mm (24 in), low profile design for precise handling of products and small spaces



### 2700 Medium Duty Conveyors

- 60 mm (2.4 in) roller diameter, widths from 203 mm (8 in) to 914 mm (36 in), larger frame and bearings for greater load capacity



### Sleek Frame Designs

- Sturdy single-piece frame with universal T-Slot for fast and simple attachment of accessories and guiding with industry available hardware



### Precision Move

- Provides accurate alignment of both time and distance to move products efficiently in assembly automation applications



### iDrive

- The industry's most compact drive saves space and reduces integration time



### LPZs

- Sleek, low profile Z-Frame Conveyors are ideal for product elevation changes and can easily fit under machinery

## The Benefits of a DORNER 2200/2700 Series Conveyor

### Low Maintenance

- DORNER's industry best v-guiding provides positive belt tracking, even under demanding side load applications
- Precise rack and pinion belt tensioning allows for fast and simple tensioning
- Sealed for life bearings reduce maintenance
- Universal Drive provides flexibility in design layout and simplicity in spare part management

### Time Saving

- DORNER's online configurator engineers simple or complex conveyors to meet your needs in minutes
- The industry leading tool delivers a complete 3D CAD assembly model for instant validation of fit
- DORNER provides the industry's fastest lead times with conveyors shipping in as little as 3 business days

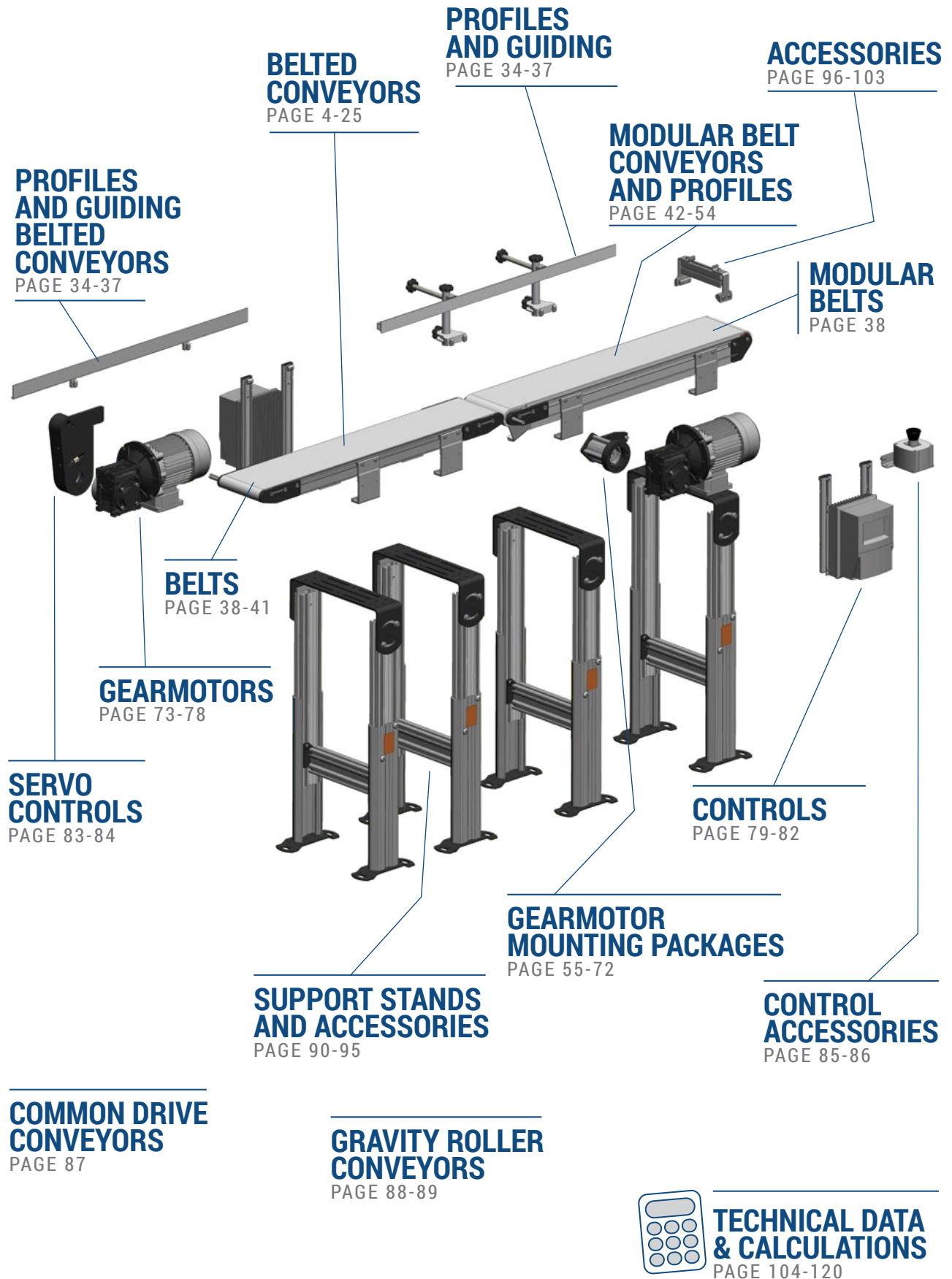

**PROFILES AND GUIDING BELTED CONVEYORS**  
PAGE 34-37

**BELTED CONVEYORS**  
PAGE 4-25

**PROFILES AND GUIDING**  
PAGE 34-37

**ACCESSORIES**  
PAGE 96-103

**MODULAR BELT CONVEYORS AND PROFILES**  
PAGE 42-54

**MODULAR BELTS**  
PAGE 38

**BELTS**  
PAGE 38-41

**GEARMOTORS**  
PAGE 73-78

**SERVO CONTROLS**  
PAGE 83-84

**CONTROLS**  
PAGE 79-82

**GEARMOTOR MOUNTING PACKAGES**  
PAGE 55-72

**SUPPORT STANDS AND ACCESSORIES**  
PAGE 90-95

**CONTROL ACCESSORIES**  
PAGE 85-86

**COMMON DRIVE CONVEYORS**  
PAGE 87

**GRAVITY ROLLER CONVEYORS**  
PAGE 88-89

**TECHNICAL DATA & CALCULATIONS**  
PAGE 104-120

**V-GROOVED  
BEDPLATE AND  
V-GUIDED BELTS**  
PROVIDE MAINTENANCE  
FREE BELT TRACKING

**HARD ANODIZED  
ALUMINUM BEDPLATE**  
PROVIDES DURABILITY  
WITHOUT ADDING WEIGHT

**URETHANE BELTING**  
FOR LONG LIFE AND VIRTUALLY  
INVISIBLE BELT SPLICE

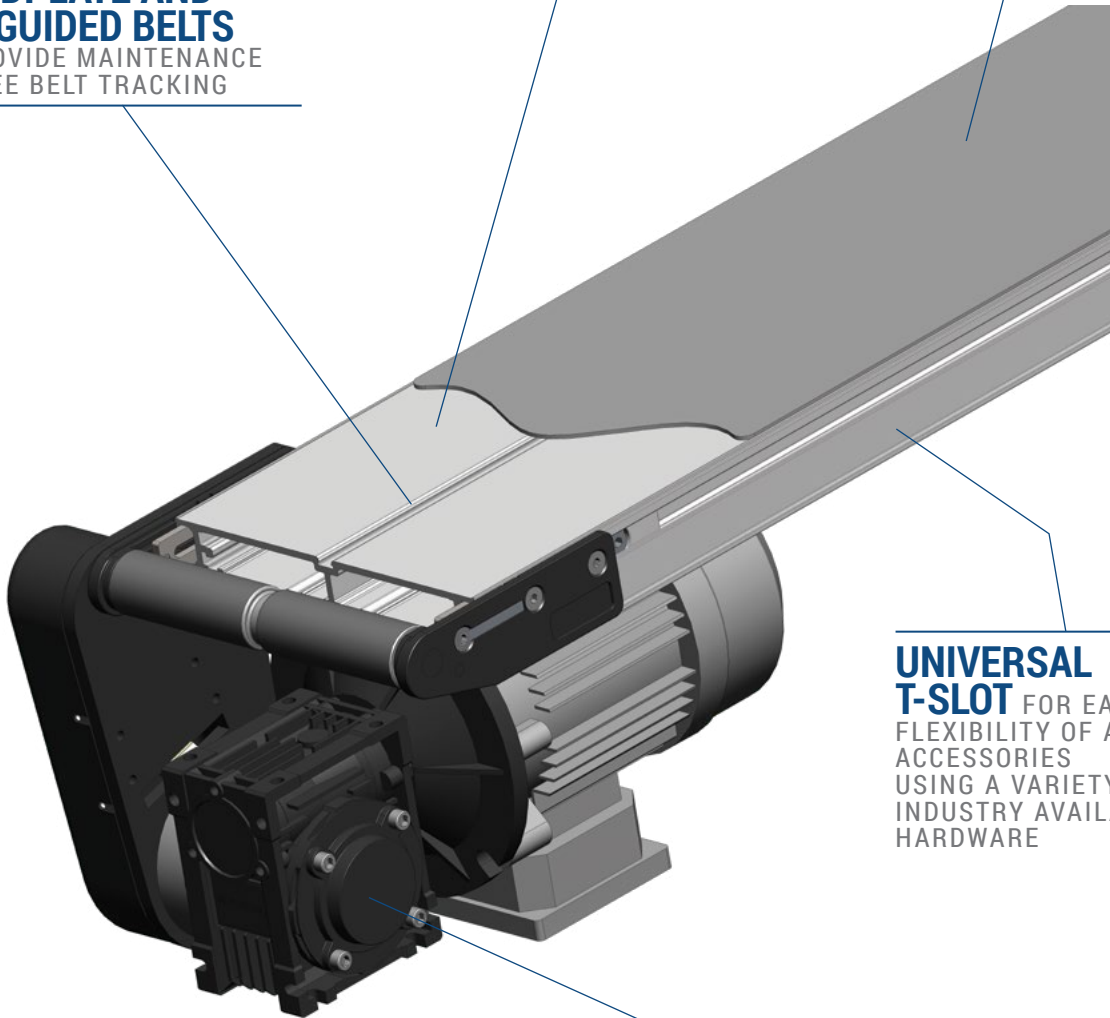

**UNIVERSAL  
T-SLOT** FOR EASE AND  
FLEXIBILITY OF ADDING  
ACCESSORIES  
USING A VARIETY OF  
INDUSTRY AVAILABLE  
HARDWARE

**eDRIVE®**  
LOW INERTIA ROTOR ALUMINUM  
BODY MOTORS PROVIDE LOW  
TEMPERATURES IN SMALL PACKAGE



**UNIVERSAL DRIVE**  
SINGLE PART NUMBER MOTOR/MOUNT/DRIVE  
PACKAGE COVERS ALL SPEED, LOAD AND MOUNTING  
POSITIONS FOR END DRIVE CONVEYORS



**Center Drive**



**Mid Drive**

**CENTER AND MID DRIVE OPTIONS**

FREES UP SPACE ON BOTH ENDS OF THE CONVEYOR AND INCREASES LOAD CAPACITY

**PATENTED RACK AND PINION BELT TENSIONING**

LOCATED IN CONVEYOR TAIL FOR EASY ACCESSIBILITY AND QUICK, ACCURATE BELT CHANGES

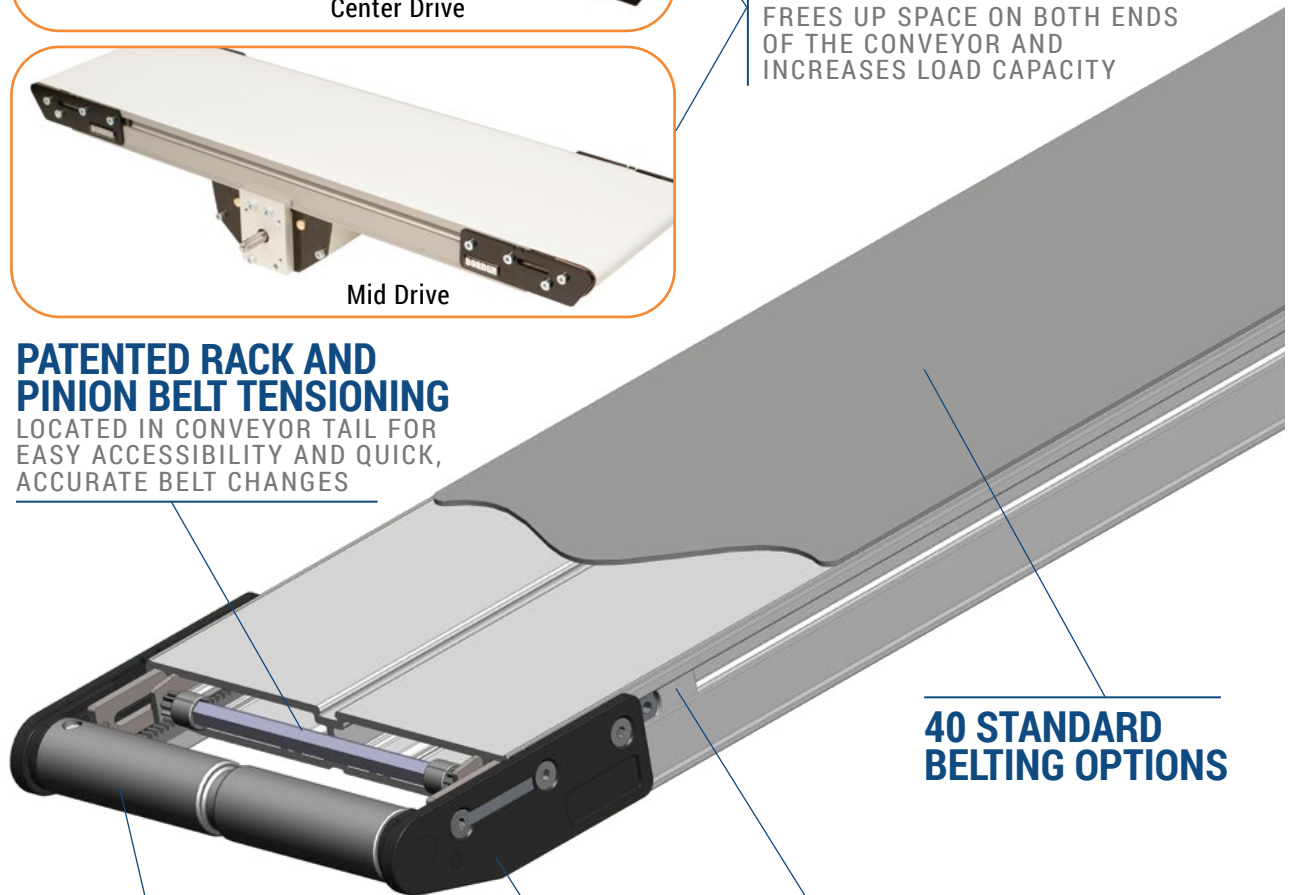

**40 STANDARD BELTING OPTIONS**

**VARIETY OF GUIDING OPTIONS**

**SPHERICAL, SEALED BALL BEARINGS**

FOR LONG, MAINTENANCE FREE LIFE

**TAIL PLATES**

MINIMAL LENGTH TAIL PLATES FOR MAXIMUM T-SLOT EXPOSURE

**PRECISE CAM TRACKING**

FOR FINE ADJUSTMENTS OF NON V-GUIDED BELTS



**5/8" & 5/16" NOSEBAR TAIL OPTIONS**

FOR SMALL PART TRANSFERS



## Specifications

- Loads up to 36 kg (80 lbs)\*
- Belt speeds up to 122 m/min (400 ft/min)
- Belt widths: 44 to 610 mm (1.75 to 24 in)
- Conveyor lengths: 457 to 5,486 mm (18 in to 18 ft)
- 32 mm (1.25 in) diameter drive and idler pulleys turn approximately 107 mm (4.2 in) of belt per revolution
- V-groove bedplate with guided belt provides belt tracking, even under demanding side load applications
  - Cam tracking standard on Non V-Guided belt conveyors
- 12 mm diameter integral drive shaft with auxiliary shaft location options



### OPTIONAL: 16 mm (5/8 in) High Speed Nose Bar Transfer Tail

Available at non-driven end.  
V-guide supported.  
Speeds up to 61 m/min (200 ft/min)



### OPTIONAL: 8 mm (5/16 in) Nose Bar Transfer Tail

Available at non-driven end.  
Speeds up to 22 m/min (75 ft/min)

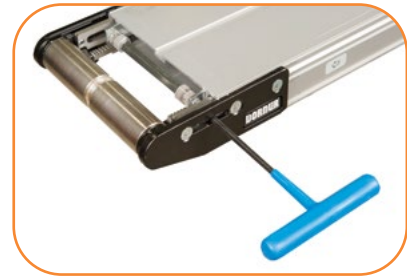

### STANDARD FEATURE: Rack and Pinion

Allows the tail section to be easily  
slid back for quick belt adjustments  
and removal

## 2200 Series Flat Belt End Drive Conveyor

22 E D M W W - L L L L 1 0 A P P P B B - X T<sup>1</sup> T<sup>2</sup> T<sup>3</sup> T<sup>4</sup>

Conveyor Tail Options X (if required) \*See Drive Shaft Position Chart on next page

A or B = Drive Shaft (T<sup>1</sup> only) C or D = Drive Shaft (T<sup>2</sup> only)

O = No Shaft

K = Keyed Auxiliary Shaft

S = Stub Shaft

M = Magnet Location (T<sup>3</sup> or T<sup>4</sup> only)

Belt Type

Profile (D side)

Profile (A side)

Flow/Drive Shaft Position: A, B, C or D

Idler Tail Type: 0 = Standard 32 mm (1.25 in), 3 = Nose Bar 8 mm (5/16 in), 5 = Nose Bar 16 mm (5/8 in)

V-Guide & Mounting Bracket Options:

1 = Non V-Guided Belt, includes mounting brackets and return rollers

4 = V-Guided Belt, without mounting brackets and return rollers

2 = V-Guided Belt, includes mounting brackets and return rollers

5 = Non V-Guided Belt, without mounting brackets, includes return rollers

3 = Non V-Guided Belt, without mounting brackets and return rollers

6 = V-Guided Belt, without mounting brackets, includes return rollers

Conveyor Length Reference: LLLL in feet

Conveyor Width Reference

Documentation Language: M = US, U = Europe

\* Conveyor load capacity depends on conveyor size, incline, motor position, accumulated loads and other factors.

Order gearmotor mounting packages and gearmotors separately, see pages 73-78  
For support stands and accessories, see pages 90-95

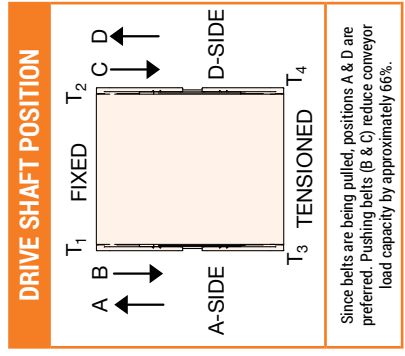
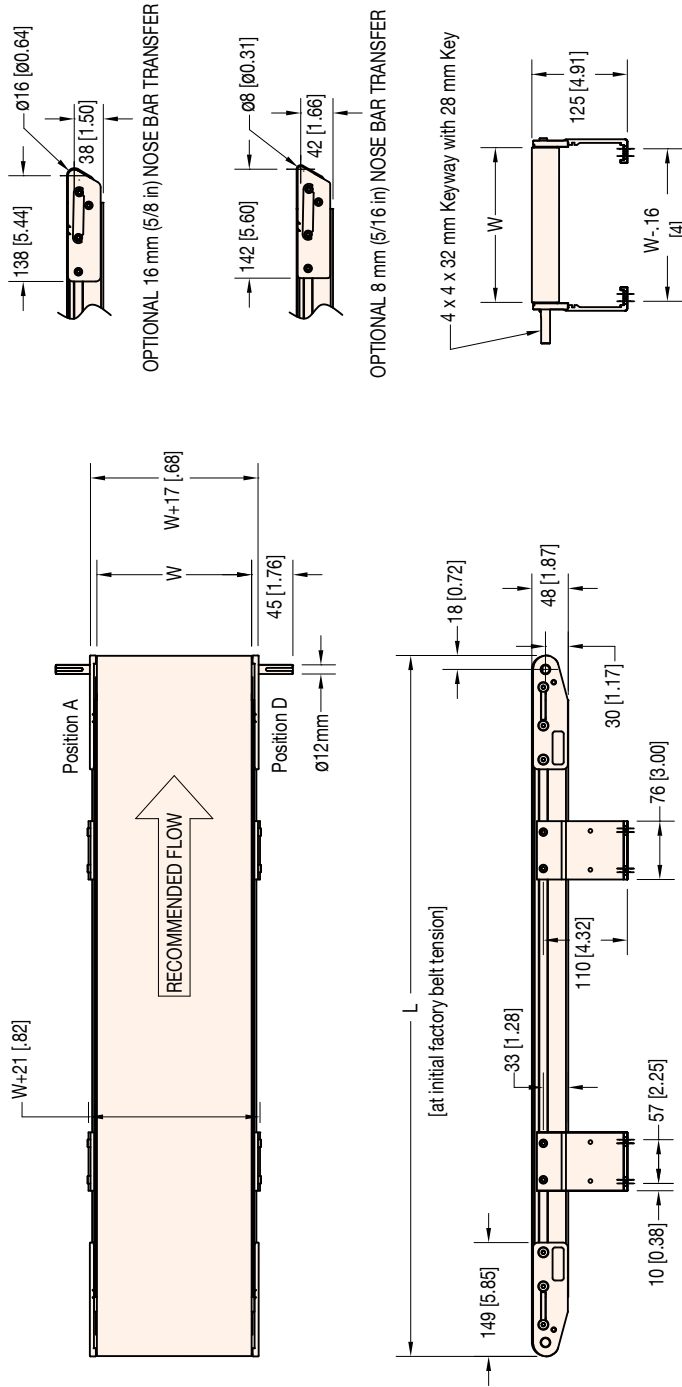

W = Conveyor Belt Width Dim = mm (in)

STANDARD SIZES		W = Conveyor Belt Width Dim = mm (in)												
<b>Conveyor Width Reference</b>	02	03	04	05	06	08	10	12	14	16	18	20	22	24
<b>Conveyor Belt Width (W)</b>	44 mm (1.75 in)	70 mm (2.75 in)	95 mm (3.75 in)	127 mm (5 in)	152 mm (6 in)	203 mm (8 in)	254 mm (10 in)	305 mm (12 in)	356 mm (14 in)	406 mm (16 in)	457 mm (18 in)	508 mm (20 in)	559 mm (22 in)	610 mm (24 in)
<b>Conveyor Length Reference</b>	0150	0001 increments up to...										1800		
<b>Conveyor Length (L)</b>	457 mm (1.5 ft)	3 mm (0.12 in) increments up to...										5,486 mm (18 ft)*		

NOTE: Conveyor widths 44-127 mm (1.75 to 5 in) wide available to 3657 mm (144 in) long only.  
 NOTE: Conveyor longer than 3,658 mm (12 ft) will be constructed using two equal length frames.  
 \*NOTE: Max length varies based on tail section.



Center Drive



**OPTIONAL:  
Compact Mid Drive**  
Small footprint to fit in tight spaces

## Specifications

- Loads up to 54 kg (120 lbs)\* (Center Drive)  
Loads up to 36 kg (80 lbs)\* (Mid Drive)
- Belt speeds up to 122 m/min (400 ft/min)
- Belt widths: 44 to 610 mm (1.75 to 24 in)
- Conveyor lengths: 457 to 7,315 mm (18 to 288 in)
- 32 mm (1.25 in) diameter drive and idler pulleys turn approximately 107 mm (4.2 in) of belt per revolution
- V-groove bedplate with guided belt provides belt tracking, even under demanding side load applications
  - Cam tracking standard on Non V-Guided belt conveyors
- 12 mm diameter integral drive shaft with auxiliary shaft location options



**OPTIONAL: 16 mm (5/8 in) High Speed  
Nose Bar Transfer Tail**

Available at non-driven end. V-guide supported.  
Speeds up to 61 m/min (200 ft/min)



**OPTIONAL: 8 mm (5/16 in) Nose  
Bar Transfer Tail**

Available at non-driven end.  
Speeds up to 22 m/min (75 ft/min)

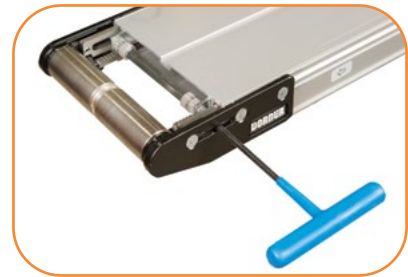

**STANDARD FEATURE:  
Rack and Pinion**

Allows the tail section to be easily slid back  
for quick belt adjustments and removal

### 2200 Series Flat Belt Mid/Center Drive Conveyor

22 CD M W W - L L L L 1 0 0 A P P P B B - X T<sup>1</sup> T<sup>2</sup> T<sup>3</sup> T<sup>4</sup>

Conveyor Tail Options X (if required) \*See Drive Shaft Position Chart on next page

0 = No Shaft

K = Keyed Auxiliary Shaft

S = Stub Shaft

M = Mag Location (T<sup>3</sup> or T<sup>4</sup> only)

Belt Type

Profile (D side)

Profile (A side)

Center/Mid Drive Shaft Position: A = A side, D = D side, E = Both sides

Tension Tail Type: 0 = Standard 32 mm (1.25 in), 3 = Nose Bar 8 mm (5/16 in), 5 = Nose Bar 16 mm (5/8 in)

Fixed Tail Type: 0 = Standard 32 mm (1.25 in), 3 = Nose Bar 8 mm (5/16 in), 5 = Nose Bar 16 mm (5/8 in)

V-Guide & Mounting Bracket Options:

1 = Non V-Guided Belt, includes mounting brackets and return rollers

4 = V-Guided Belt, without mounting brackets and return rollers

2 = V-Guided Belt, includes mounting brackets and return rollers

5 = Non V-Guided Belt, without mounting brackets, includes return rollers

3 = Non V-Guided Belt, without mounting brackets and return rollers

6 = V-Guided Belt, without mounting brackets, includes return rollers

Conveyor Length Reference: L L L L in feet

Conveyor Width Reference

Documentation Language: M = US, U = Europe

Drive Type: CD = Center Drive, MD = Mid Drive

\* Conveyor load capacity depends on conveyor size, incline, motor position, accumulated loads and other factors.

Order gearmotor mounting packages and gearmotors separately, see pages 73-78  
For support stands and accessories, see pages 90-95

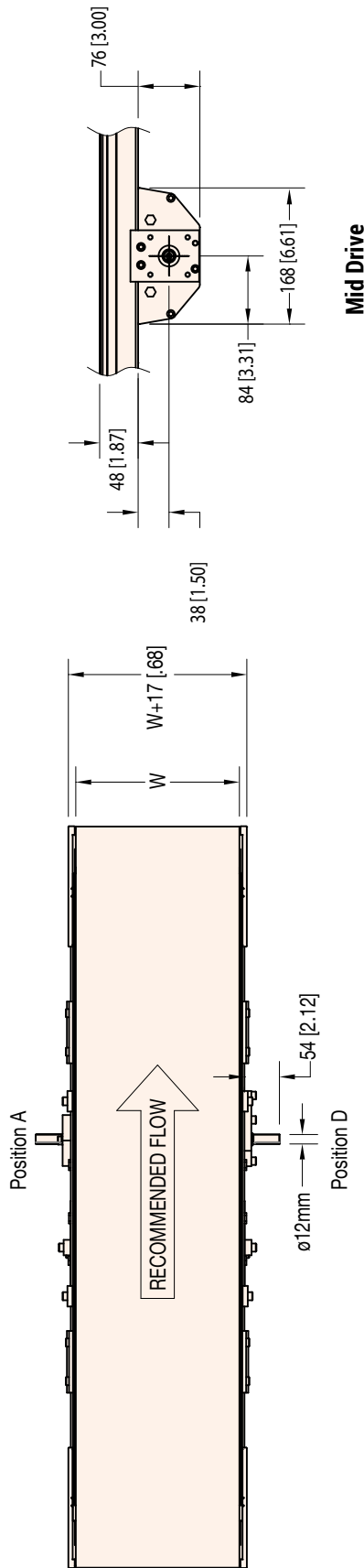

**Mid Drive**

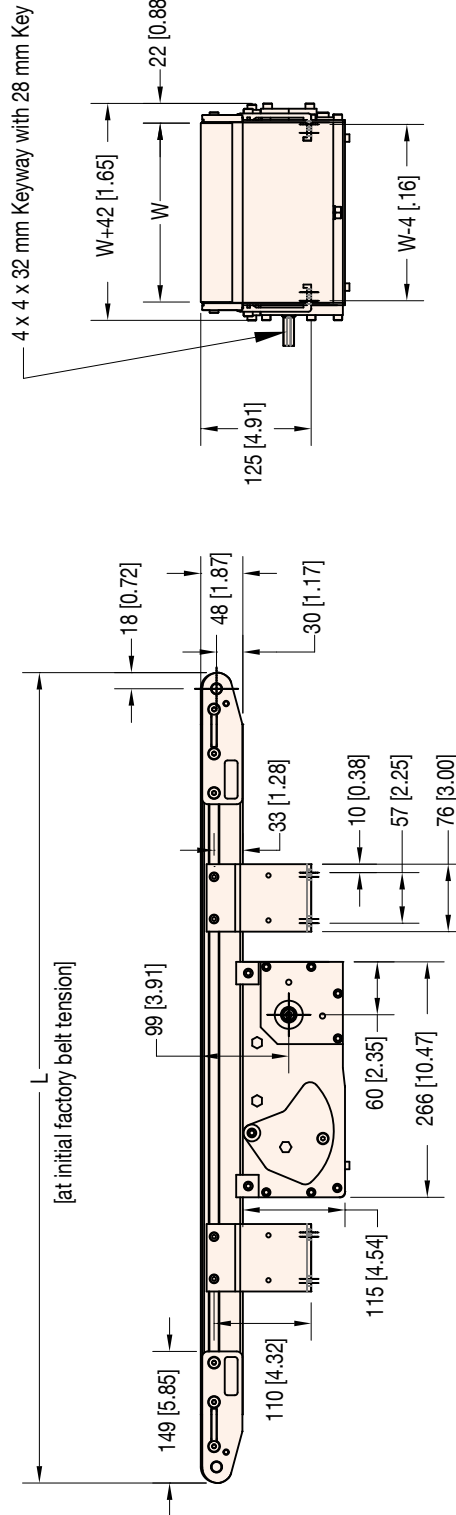

**W = Conveyor Belt Width Dim = mm (in)**

**DRIVE SHAFT POSITION**

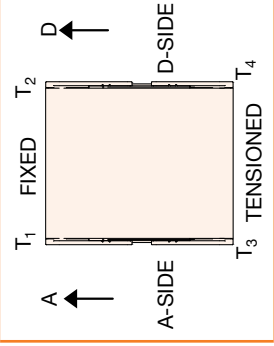

**STANDARD SIZES**

Conveyor Width Reference	02	03	04	05	06	08	10	12	14	16	18	20	22	24
Conveyor Belt Width (W)	44 mm (1.75 in)	70 mm (2.75 in)	95 mm (3.75 in)	127 mm (5 in)	152 mm (6 in)	203 mm (8 in)	254 mm (10 in)	305 mm (12 in)	356 mm (14 in)	406 mm (16 in)	457 mm (18 in)	508 mm (20 in)	559 mm (22 in)	610 mm (24 in)
Conveyor Length Reference	0150													
Conveyor Length (L)	457 mm (1.5 ft)													
Conveyor Length Reference	0150													
Conveyor Length (L)	3 mm (0.12 in) increments up to... 7,315 mm (24 ft)*													

NOTE: Conveyor widths 44-127 mm (1.75 to 5 in) wide available to 3657 mm (144 in) long only.  
 \*NOTE: Max length varies based on tail section.



## Specifications

- Loads up to 36 kg (80 lbs)\*
- Belt speeds up to 122 m/min (400 ft/min)
- Belt widths: 44 to 610mm (1.75 to 24 in)
- Conveyor lengths: 457 to 5,486 mm (18 in to 18 ft)
- Cleats available from 6 to 60 mm to (0.24 to 2.36 in) high
- 32 mm (1.25 in) diameter drive and idler pulleys turn approximately 107 mm (4.2 in) of belt per revolution
- V-groove bedplate with guided belt provides belt tracking, even under demanding side load applications
  - Cam tracking standard on Non V-Guided belt conveyors
- 12 mm diameter integral drive shaft with auxiliary shaft location options



### OPTIONAL: Fixed and Tension Tail Shafts and Sensor Accessories

Easily allows for common driven applications or monitoring devices to be added

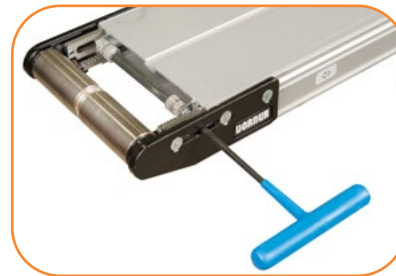

### STANDARD FEATURE: Rack and Pinion

Allows the tail section to be easily slid back for quick belt adjustments and removal

#### 2200 Series Cleated Belt End Drive Conveyor

22	C	T	M	WW	-	LLLL	1	A	C	P	SSSS	L	-	X	T <sup>1</sup>	T <sup>2</sup>	T <sup>3</sup>	T <sup>4</sup>
															Conveyor Tail Options X (if required) *See Drive Shaft Position Chart on next page			
															A or B = Drive Shaft (T <sup>1</sup> only)		C or D = Drive Shaft (T <sup>2</sup> only)	
															O = No Shaft		K = Keyed Auxiliary Shaft	
															S = Stub Shaft		M = Mag Location (T <sup>3</sup> or T <sup>4</sup> only)	
															Belt Type: L = Low Friction Belt, H = Standard Belt			
															Cleat Spacing: SS.SS in inches			
															Profile Type			
															Cleat Type			
															Flow/Drive Shaft Position: A, B, C or D			
															V-Guide & Mounting Bracket Options:			
															1 = Non V-Guided Belt, includes mounting brackets and return rollers		4 = V-Guided Belt, without mounting brackets and return rollers	
															2 = V-Guided Belt, includes mounting brackets and return rollers		5 = Non V-Guided Belt, without mounting brackets, includes return rollers	
															3 = Non V-Guided Belt, without mounting brackets and return rollers		6 = V-Guided Belt, without mounting brackets, includes return rollers	
															Conveyor Length Reference: LLLL in feet			
															Conveyor Width Reference			
															Documentation Language: M = US, U = Europe			

\* Conveyor load capacity depends on conveyor size, incline, motor position, accumulated loads and other factors.

Order gearmotor mounting packages and gearmotors separately, see pages 73-78  
For support stands and accessories, see pages 90-95

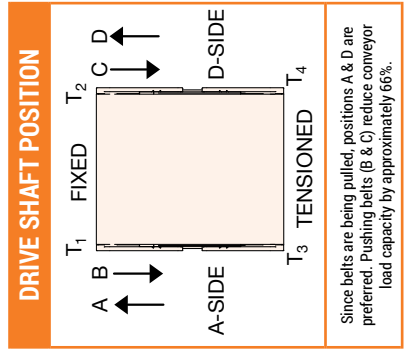
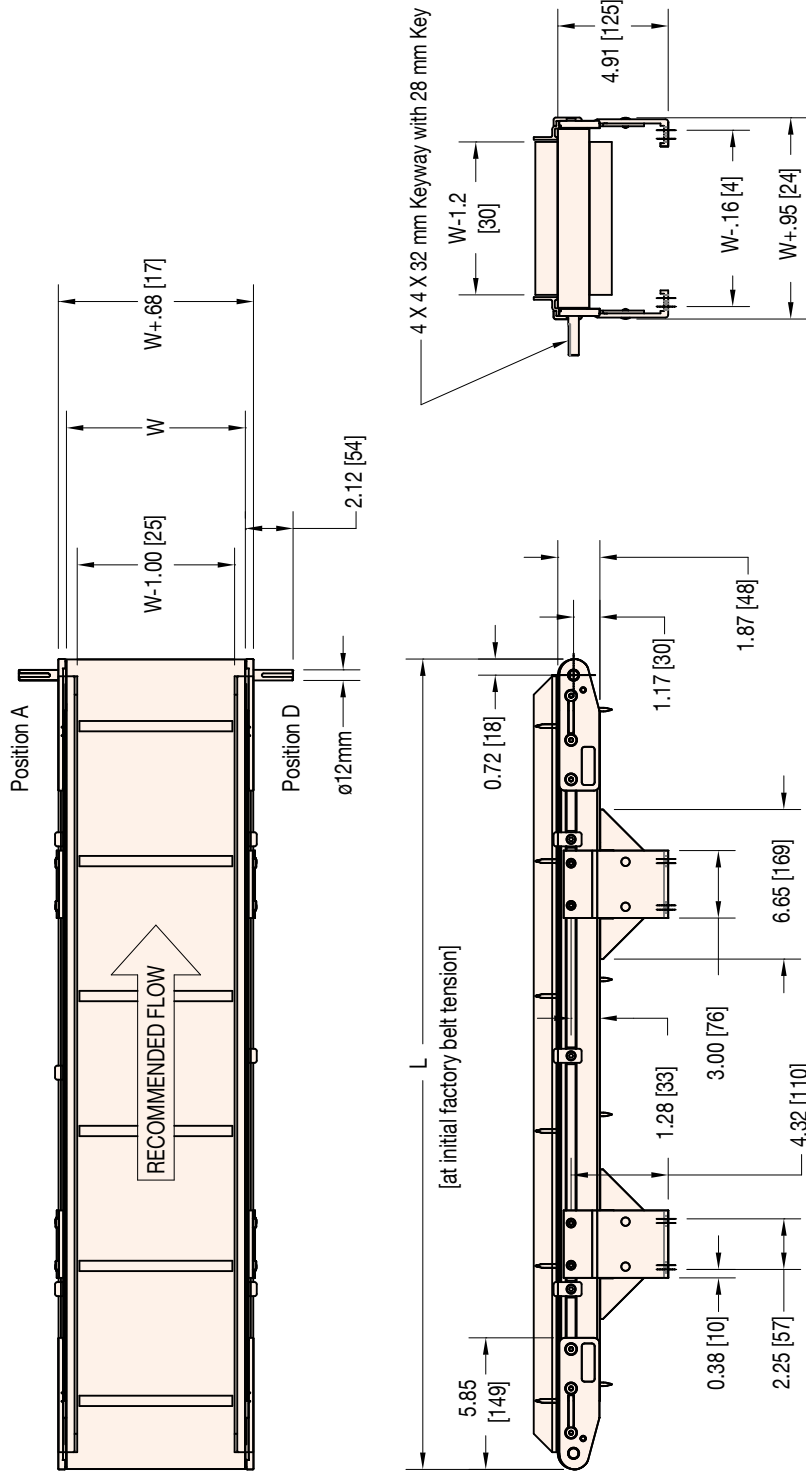

W = Conveyor Belt Width Dim = mm (in)

STANDARD SIZES														
<b>Conveyor Width Reference</b>	02	03	04	05	06	08	10	12	14	16	18	20	22	24
<b>Conveyor Belt Width (W)</b>	44 mm (1.75 in)	70 mm (2.75 in)	95 mm (3.75 in)	127 mm (5 in)	152 mm (6 in)	203 mm (8 in)	254 mm (10 in)	305 mm (12 in)	356 mm (14 in)	406 mm (16 in)	457 mm (18 in)	508 mm (20 in)	559 mm (22 in)	610 mm (24 in)
<b>Conveyor Length Reference</b>	0150													
<b>Conveyor Length (L)</b>	457 mm (1.5 ft)													
0001 increments up to...														
3 mm (0.12 in) increments up to...														
1800														
5,486 mm (18 ft)														

NOTE: Conveyor widths 44-127 mm (1.75 to 5 in) wide available to 3657 mm (144 in) long only.  
 NOTE: Conveyors longer than 3,658 mm (12 ft) will be constructed using two equal length frames.

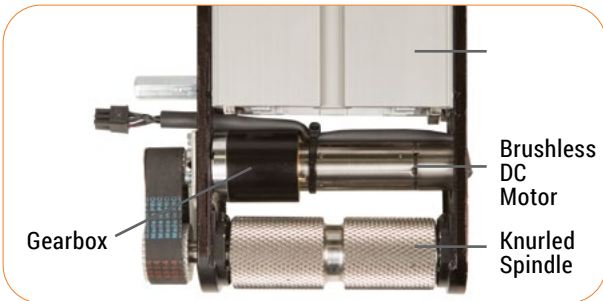

## Specifications

- Conveyor Load Capacity (non-accumulated, distributed load):
  - 0.5 to 5 m/min (1.7 to 17 ft/min) – Up to 11.3 kg (25 lbs)
  - 0.9 to 7 m/min (3 to 24 ft/min) – Up to 11.3 kg (25 lbs)
  - 1.5 to 15 m/min (5 to 50 ft/min) – Up to 11.3 kg (25 lbs)
  - 2 to 21 m/min (7 to 70 ft/min) – Up to 5.4 kg (12 lbs)
- Belt Speeds: Variable Speed, (4) Speed Options
  - 0.5 to 5 m/min (1.7 to 17 ft/min)
  - 0.9 to 7 m/min (3 to 24 ft/min)
  - 1.5 to 15 m/min (5 to 50 ft/min)
  - 2 to 21 m/min (7 to 70 ft/min)
- Belt Widths: 51 to 610 mm (2 to 24 in)
- Conveyor Lengths: 457 to 2,438 mm (18 in to 8 ft)
- V-groove bedplate with guided belt provides belt tracking, even under demanding side load applications
  - Cam tracking standard on Non V-Guided belt conveyors
- Indexing Capable – Up to 30 indexes per minute
- iDrive Controls
  - Integrated Forward/Off/Reverse switch and variable speed pot
  - Flying leads remote start/stop with integrated direction switch and speed pot.
  - Power supply available

### 2200 Series Flat Belt iDrive Conveyor

22	E	D	M	W	W	-	L	L	L	L	I	O	A	P	P	P	B	B	-	F	D	C	P	S
																							Speed Range: A = 7-70 FPM, B = 5-50 FPM, C = 3-24 FPM, D = 1.7-17 FPM	
																							Power Supply: P = Power Supply Included, N = No Power Supply	
																							Control Type: M = Mounted Full Control, Q = Remote Start/Stop w/6' cord, R = Remote Start/Stop w/9 m (30ft) cord	
																							Integrated Frame Drive	
																							Belt Type	
																							Profile (D side)	
																							Profile (A side)	
																							Controls/Flow/Drive Shaft Position: A, B, C or D	
																							Idle Tail Type: 0 = Standard 32 mm (1.25 in), 3 = Nose Bar 8 mm (5/16 in), 5 = Nose Bar 16 mm (5/8 in)	
																							V-Guide & Mounting Bracket Options:	
																							1 = Non V-Guided Belt, includes mounting brackets and return rollers	
																							2 = V-Guided Belt, includes mounting brackets and return rollers	
																							3 = Non V-Guided Belt, without mounting brackets and return rollers	
																							4 = V-Guided Belt, without mounting brackets and return rollers	
																							5 = Non V-Guided Belt, without mounting brackets, includes return rollers	
																							6 = V-Guided Belt, without mounting brackets, includes return rollers	
																							Conveyor Length Reference: LLLL in feet	
																							Conveyor Width Reference	
																							Documentation Language: M = US, U = Europe	

### 2200 Series Cleated Belt iDrive Conveyor

22	C	T	M	W	W	-	L	L	L	L	I	A	C	P	S	S	S	S	S	L	-	F	D	C	P	S	
																											Speed Range: A = 7-70 FPM, B = 5-50 FPM, C = 3-24 FPM, D = 1.7-17 FPM
																											Power Supply: P = Power Supply Included, N = No Power Supply
																											Control Type: M = Mounted Full Control, Q = Remote Start/Stop w/6' cord, R = Remote Start/Stop w/9 m (30ft) cord
																											Integrated Frame Drive
																											Belt Type: L = Low Friction Belt, H = Standard Belt
																											Cleat Spacing: SS.SS in inches
																											Profile Type
																											Cleat Type
																											Controls/Flow/Drive Shaft Position: A, B, C or D
																											V-Guide & Mounting Bracket Options:
																											1 = Non V-Guided Belt, includes mounting brackets and return rollers
																											2 = V-Guided Belt, includes mounting brackets and return rollers
																											3 = Non V-Guided Belt, without mounting brackets and return rollers
																											4 = V-Guided Belt, without mounting brackets and return rollers
																											5 = Non V-Guided Belt, without mounting brackets, includes return rollers
																											6 = V-Guided Belt, without mounting brackets, includes return rollers
																											Conveyor Length Reference: LLLL in feet
																											Conveyor Width Reference
																											Documentation Language: M = US, U = Europe

\* Conveyor load capacity depends on conveyor size, incline, motor position, accumulated loads and other factors.

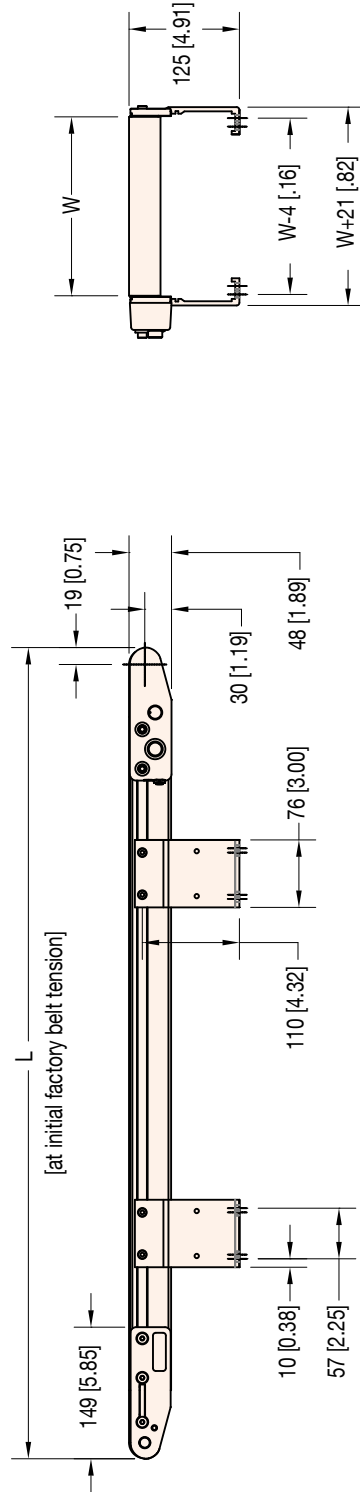
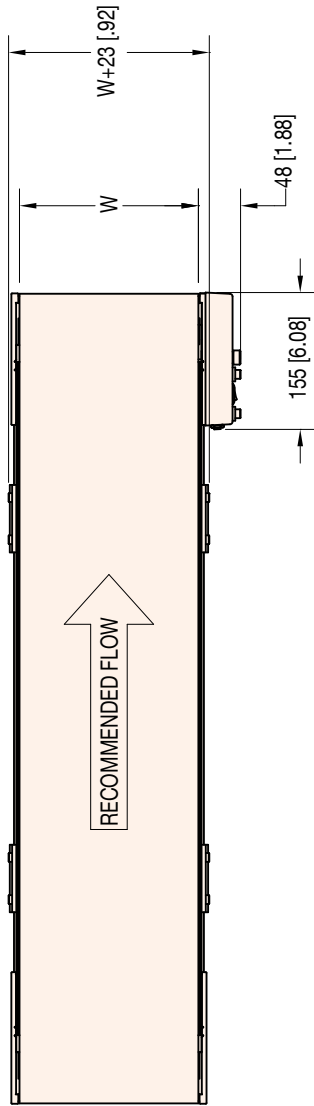

### DRIVE SHAFT POSITION

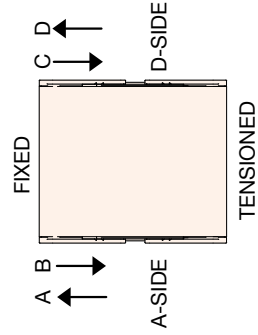

W = Conveyor Belt Width Dim = mm (in)

STANDARD SIZES		W = Conveyor Belt Width Dim = mm (in)												
Conveyor Width Reference	02	03	04	05	06	08	10	12	14	16	18	20	22	24
Conveyor Belt Width (W)	44 mm (1.75 in)	70 mm (2.75 in)	95 mm (3.75 in)	127 mm (5 in)	152 mm (6 in)	203 mm (8 in)	254 mm (10 in)	305 mm (12 in)	356 mm (14 in)	406 mm (16 in)	457 mm (18 in)	508 mm (20 in)	559 mm (22 in)	610 mm (24 in)
Conveyor Length Reference	0150	0001 increments up to...												
Conveyor Length (L)	457 mm (1.5 ft)	3 mm (0.12 in) increments up to...												
		0800												
		2,438 mm (8 ft)*												

NOTE: Duty cycle not continuous rated.  
 NOTE: Conveyors longer than 3,658 mm (12 ft) will be constructed using two equal length frames.  
 \*NOTE: Max length varies based on tail section.



## Specifications

- Loads up to 36 kg (80 lbs)\*
- Belt speeds up to 76 m/min (250 ft/min)
- Belt widths: 44 to 610 mm (1.75 to 24 in)
- Conveyor lengths: 610 to 5,486 mm (24 in to 18 ft)
- Fixed angle: 5°, 10°, 15°, and 20°
- 32 mm (1.25 in) diameter drive and idler pulleys turn approximately 107 mm (4.2 in) of belt per revolution
- V-groove bedplate with guided belt provides positive belt tracking, even under demanding side load applications

## Configurations

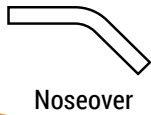

Noseover



### OPTIONAL: 16 mm (5/8 in) High Speed Nose Bar Transfer Tail

Available at non-driven end.  
V-guide supported. Speeds up to  
61 m/min (200 ft/min)



### OPTIONAL: Fixed and Tension Tail Shafts and Sensor Accessories

Easily allows for common driven  
applications or monitoring devices  
to be added

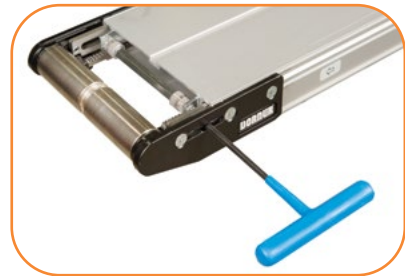

### STANDARD FEATURE: Rack and Pinion

Allows the tail section to be easily  
slid back for quick belt adjustments  
and removal

## 2200 Series Z-Frame Flat Belt End Drive Conveyor

22 E D M W W - L L L L - L L L L A A E 1 0 A P P B B - X T<sup>1</sup> T<sup>2</sup> T<sup>3</sup> T<sup>4</sup>

Conveyor Tail Options X (if required) \*See Drive Shaft Position Chart on next page

A or B = Drive Shaft (T<sup>1</sup> only)

C or D = Drive Shaft (T<sup>2</sup> only)

O = No Shaft

K = Keyed Auxiliary Shaft

S = Stub Shaft

M = Mag Location (T<sup>3</sup> or T<sup>4</sup> only)

Belt Type

Profile

Flow/Drive Shaft Position: A, B, C or D

Idler Tail Type: 0 = Standard 32 mm (1.25 in), 5 = Nose Bar 16 mm (5/8 in)

V-Guide & Mounting Bracket Options:

1 = Non V-Guided Belt, includes mounting brackets and return rollers

4 = V-Guided Belt, without mounting brackets and return rollers

2 = V-Guided Belt, includes mounting brackets and return rollers

5 = Non V-Guided Belt, without mounting brackets, includes return rollers

3 = Non V-Guided Belt, without mounting brackets and return rollers

6 = V-Guided Belt, without mounting brackets, includes return rollers

Belt Direction: E = Incline D = Decline

Angle: 05 = 5°, 10 = 10°, 15 = 15°, 20 = 20°

Incline Section Length Reference: L.L.L.L in feet

Horizontal Section Length Reference: L.L.L.L in feet

Conveyor Width Reference

Documentation Language: M = US, U = Europe

\* Conveyor load capacity depends on conveyor size, incline, motor position, accumulated loads and other factors.

Order gearmotor mounting packages and gearmotors separately, see pages 73-78  
For support stands and accessories, see pages 90-95

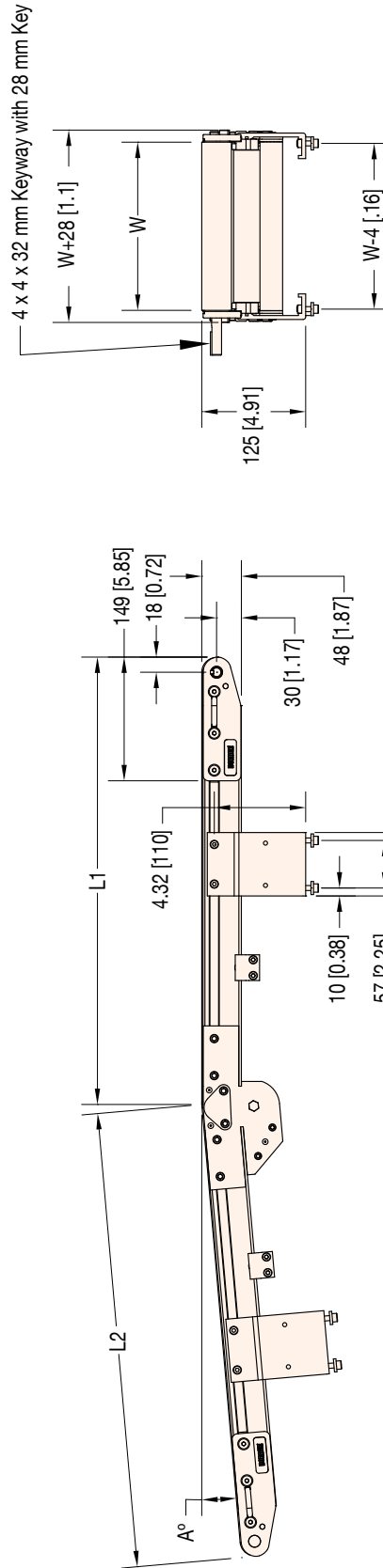
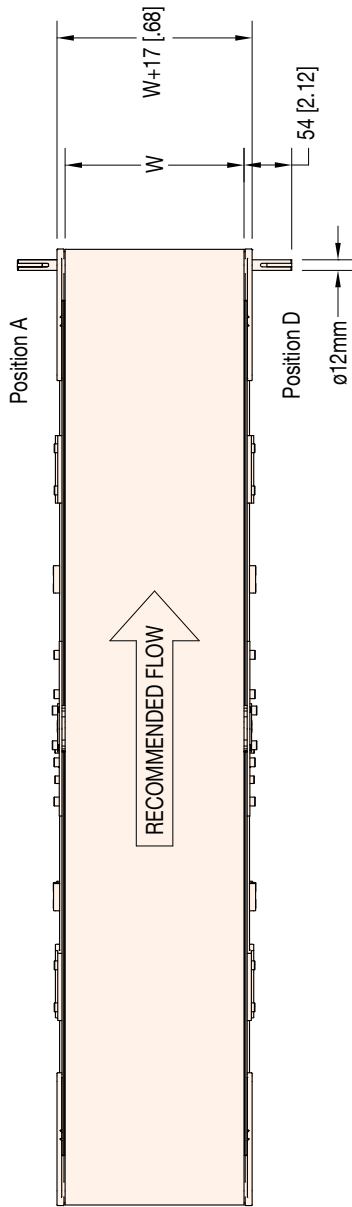

**W = Conveyor Belt Width Dim = mm (in)**  
**Note: Belt direction is not reversible**

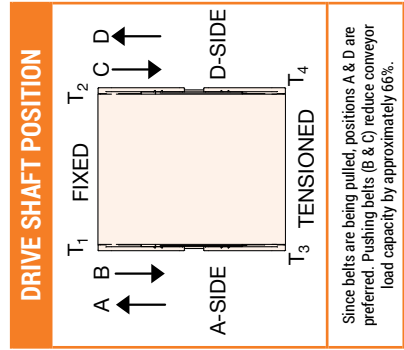

Since belts are being pulled, positions A & D are preferred. Pushing belts (B & C) reduce conveyor load capacity by approximately 66%.

STANDARD SIZES														
Conveyor Width Reference	02	03	04	05	06	08	10	12	14	16	18	20	22	24
Conveyor Belt Width (W)	44 mm (1.75 in)	70 mm (2.75 in)	95 mm (3.75 in)	127 mm (5 in)	152 mm (6 in)	203 mm (8 in)	254 mm (10 in)	305 mm (12 in)	356 mm (14 in)	406 mm (16 in)	457 mm (18 in)	508 mm (20 in)	559 mm (22 in)	610 mm (24 in)
Conveyor Length Reference	0200													
Section Length (L1 or L2)	610 mm (2 ft)													
L1 + L2 Maximum Conveyor Length	3658mm (12 ft)													
	0001 increments up to...													
	3 mm (0.12 in) increments up to...													
	1000													
	3048 mm (10 ft)													
	5486 mm (18 ft)*													

\*NOTE: Max length varies based on tail section.



## Specifications

- Loads up to 23 kg (50 lbs)\*
- Belt speeds up to 76 m/min (250 ft/min)
- Belt widths: 44 to 610 mm (6 to 24 in)
- Conveyor lengths: 610 to 5,486 mm (24 in to 18 ft)
- Fixed angle: 30°, 45°, and 60°
- Cleats available from 6 to 60 mm (0.24 to 2.36 in) high
- 32 mm (1.25 in) diameter drive and idler pulleys turn approximately 107 mm (4.2 in) of belt per revolution
- V-groove bedplate with guided belt provides positive belt tracking, even under demanding side load applications

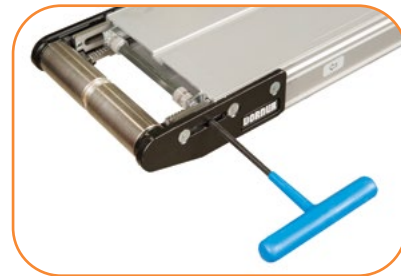

### STANDARD FEATURE: Rack and Pinion

Allows the tail section to be easily slid back for quick belt adjustments and removal

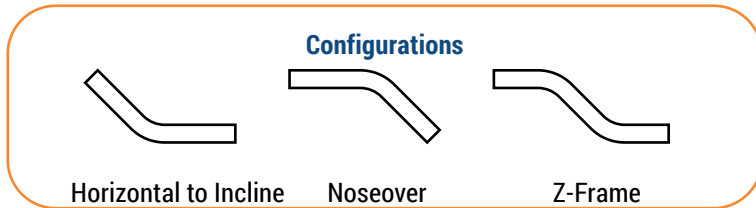

### 2200 Series Z-Frame Cleated Belt End Drive Conveyor

22	C	T	M	W	W	-	L	L	L	L	-	L	L	L	L	L	A	A	E	1	A	C	P	S	S	S	S	-	X	T <sup>1</sup>	T <sup>2</sup>	T <sup>3</sup>	T <sup>4</sup>
<p><b>Conveyor Tail Options X</b> (if required) *See Drive Shaft Position Chart on next page  <b>A or B</b> = Drive Shaft (T<sup>1</sup> only)      <b>C or D</b> = Drive Shaft (T<sup>2</sup> only)  <b>O</b> = No Shaft      <b>K</b> = Keyed Auxiliary Shaft  <b>S</b> = Stub Shaft      <b>M</b> = Mag Location (T<sup>3</sup> or T<sup>4</sup> only)</p> <p><b>Cleat Spacing:</b> SS.SS in inches</p> <p><b>Profile Type</b></p> <p><b>Cleat Type</b></p> <p><b>Flow/Drive Shaft Position:</b> A, B, C or D</p> <p><b>V-Guide &amp; Mounting Bracket Options:</b>                      1 = Non V-Guided Belt, includes mounting brackets and return rollers      5 = Non V-Guided Belt, without mounting brackets, includes return rollers                      2 = V-Guided Belt, includes mounting brackets and return rollers      6 = V-Guided Belt, without mounting brackets, includes return rollers</p> <p><b>Belt Direction:</b> E = Incline D = Decline</p> <p><b>Angle:</b> 30 = 30°, 45 = 45°, 60 = 60°</p> <p><b>L3 Section Length Reference:</b> LL.LL in feet</p> <p><b>L2 Section Length Reference:</b> LL.LL in feet</p> <p><b>L1 Section Length Reference:</b> LL.LL in feet</p> <p><b>Conveyor Width Reference</b></p> <p><b>Documentation Language:</b> M = US, U = Europe</p>																																	

\* Conveyor load capacity depends on conveyor size, incline, motor position, accumulated loads and other factors.

Order gearmotor mounting packages and gearmotors separately, see pages 73-78  
 For support stands and accessories, see pages 90-95

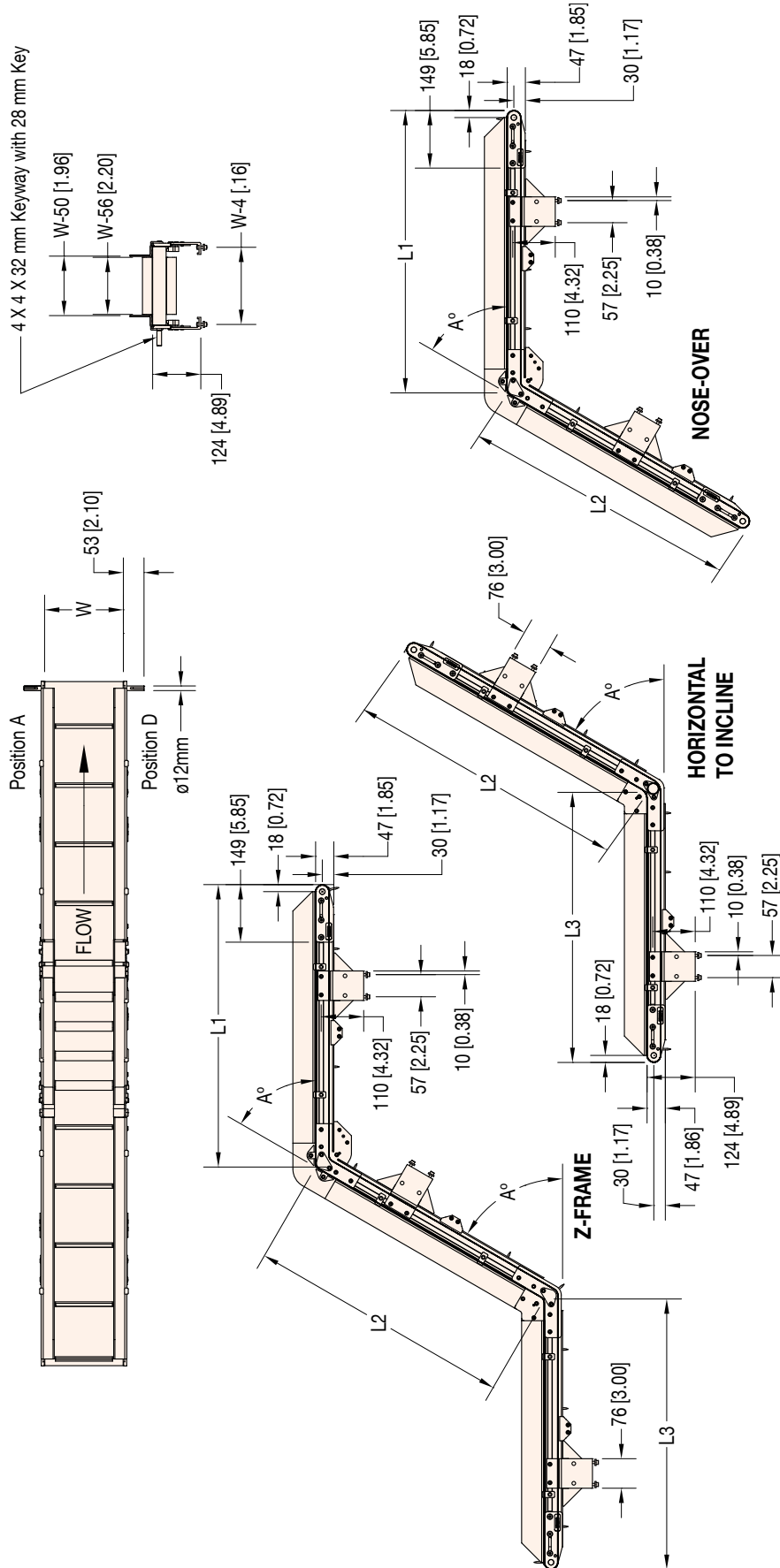

W = Conveyor Belt Width Dim = mm (in)  
 Note: Belt direction is not reversible

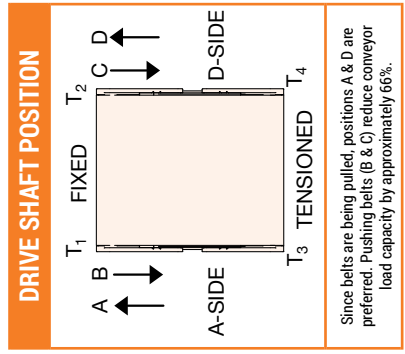

STANDARD SIZES		W = Conveyor Belt Width Dim = mm (in)									
Conveyor Width Reference	06	08	10	12	14	16	18	20	22	24	
Conveyor Belt Width (W)*	152 mm (6 in)	203 mm (8 in)	254 mm (10 in)	305 mm (12 in)	356 mm (14 in)	406 mm (16 in)	457 mm (18 in)	508 mm (20 in)	559 mm (22 in)	610 mm (24 in)	
Pocket Width	102 mm (4 in)	152 mm (6 in)	203 mm (8 in)	254 mm (10 in)	305 mm (12 in)	356 mm (14 in)	406 mm (16 in)	457 mm (18 in)	508 mm (20 in)	559 mm (22 in)	
Conveyor Length Reference	0200										1000
Section Length (L1, L2, or L3)	610 mm (2 in)										3048 mm (10 ft)**
L1 + L2 + L3 Maximum Conveyor Length	0001 increments up to...										5486 mm (18 ft)

\*Note: 30 deg knuckles available for 152 - 406 mm (6 - 16 in) belt widths only  
 \*\*NOTE: Max length varies based on tail section.



## IDrive2 CONTINUOUS DUTY 24VDC MOTORS

THE MOST COMPACT CONVEYOR DRIVE PACKAGE. INTERNAL GEARMOTOR ALLOWS THE CONVEYOR TO FIT IN TIGHT SPACES

## HARD ANODIZED ALUMINUM BEDPLATE

PROVIDES DURABILITY WITHOUT ADDING WEIGHT

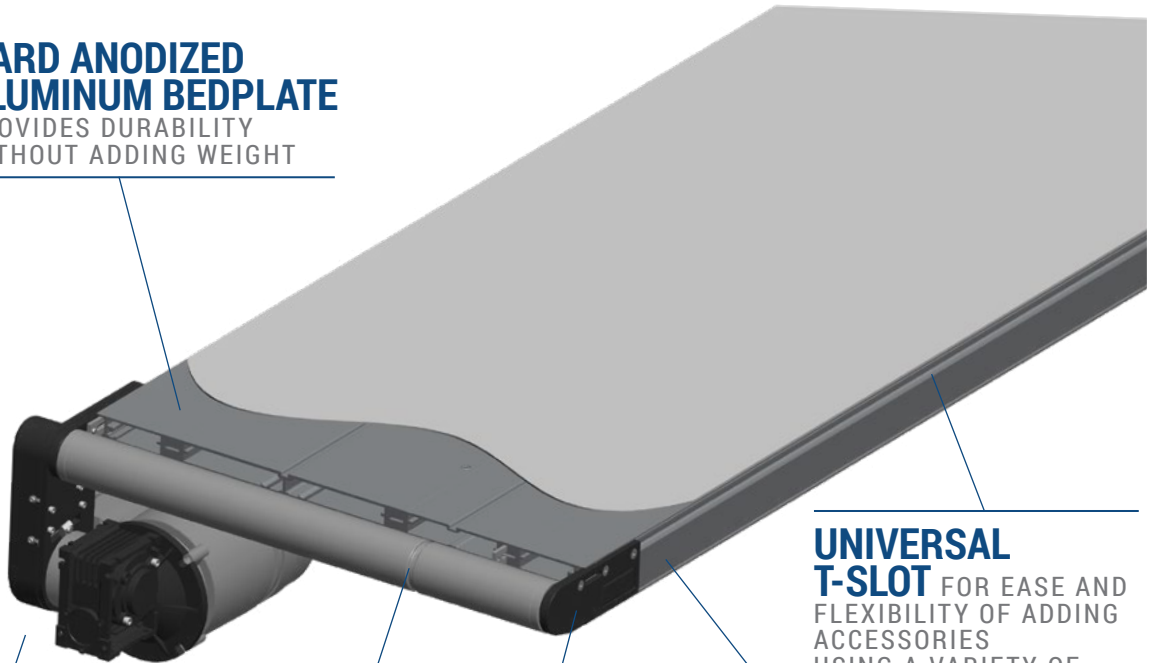

## MOTOR MOUNT PACKAGES

VARIETY OF CONFIGURATIONS PROVIDES THE FLEXIBILITY TO SELECT THE EXACT PRODUCT FOR THE APPLICATION

## STANDARD PRECISE CAM TRACKING

FOR FINE ADJUSTMENTS OF NON V-GUIDED BELTS

## UNIVERSAL T-SLOT

FOR EASE AND FLEXIBILITY OF ADDING ACCESSORIES USING A VARIETY OF INDUSTRY AVAILABLE HARDWARE

## V-GROOVED BEDPLATE AND V-GUIDED BELTS

PROVIDE MAINTENANCE-FREE BELT TRACKING AND ALLOW CONVEYOR TO BE WIDER THAN LONG FOR AGV/ARM APPLICATIONS

## SMALL CONVEYOR FRAME HEIGHT WITH LARGE BEARINGS

MAKING THIS CONVEYOR COMPACT WHILE ABLE TO HANDLE LARGE LOADS



## AUXILIARY SHAFT

ADDITIONAL SHAFTS ON ANY CORNER OF THE CONVEYOR FOR EASY INTEGRATION OF SENSORS OR ATTACHMENTS



**MID DRIVE OPTION**  
FREES UP SPACE ON BOTH  
ENDS OF THE CONVEYOR

**PATENTED RACK AND  
PINION BELT TENSIONING**  
LOCATED IN CONVEYOR TAIL FOR  
EASY ACCESSIBILITY AND QUICK,  
ACCURATE BELT CHANGES

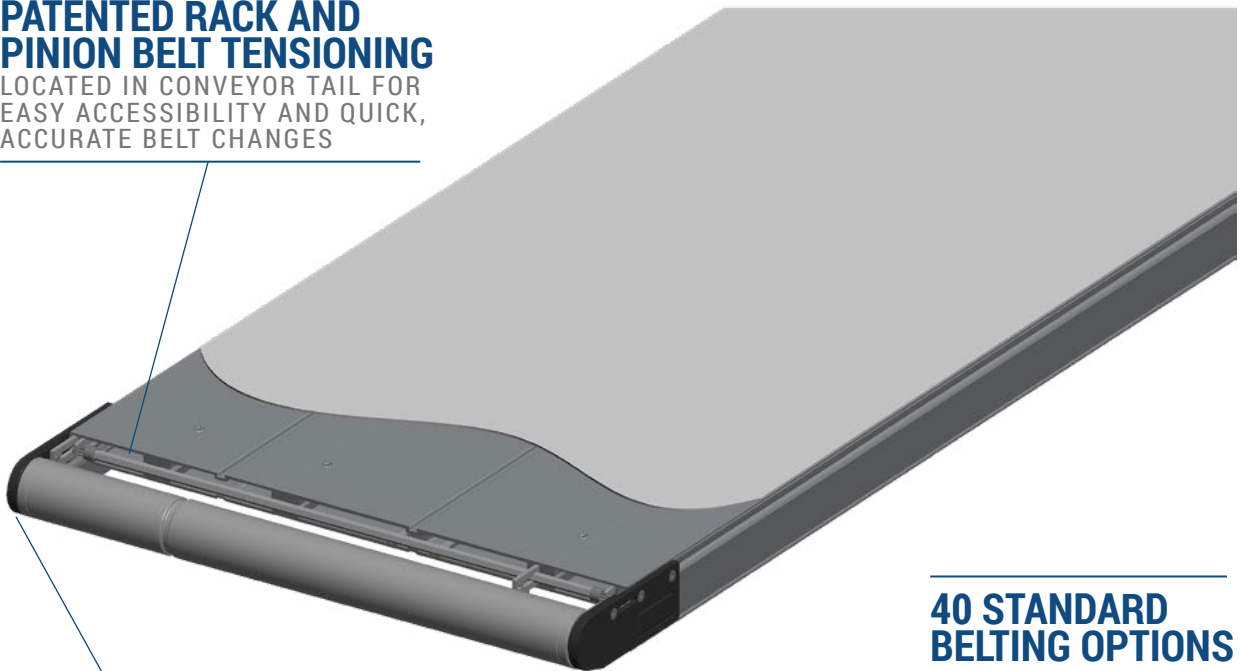

**40 STANDARD  
BELTING OPTIONS**

**LARGE CAPACITY,  
SEALED BALL  
BEARINGS**  
FOR LONG, MAINTENANCE  
FREE LIFE

**TAIL PLATES**  
MINIMAL LENGTH  
TAIL PLATES FOR  
MAXIMUM T-SLOT  
EXPOSURE

**VARIETY OF  
GUIDING OPTIONS**



**5/8" NOSEBAR TAIL OPTIONS**  
FOR PRECISE SMALL PART TRANSFER



## Specifications

- Loads up to 68 kg (150 lbs)\*
- Belt speeds up to 122 m/min (400 ft/min)
- Belt widths: 203 to 914 mm (8 to 36 in)
- Conveyor lengths: 508 to 7315 mm (20 in to 24 ft)
- 60 mm (2.4 in) diameter drive and idler pulleys turn approximately 189 mm (7.4 in) of belt per revolution
- V-groove bedplate with guided belt provides belt tracking, even under demanding side load applications
  - Cam tracking standard on Non V-Guided belt conveyors
- 15 mm diameter integral drive shaft with auxiliary shaft location options



### OPTIONAL:

#### 16 mm (5/8 in) High Speed Nose Bar Transfer Tail

Available at non-driven end.  
V-guide supported.  
Speeds up to 61 m/min (200 ft/min)



### OPTIONAL:

#### 15 mm diameter integrated auxiliary shaft

Available on any corner of the conveyor



### STANDARD FEATURE: Rack and Pinion

Allows the tail section to be easily slid back for quick belt adjustments and removal

### 2700 Series Flat Belt End Drive Conveyor

2 L E D M W W - L L L L 1 0 A P P P B B - X T<sup>1</sup> T<sup>2</sup> T<sup>3</sup> T<sup>4</sup>

Conveyor Tail Options X (if required) 0 = No Shaft, K = Keyed Auxiliary Shaft

Belt Type See Note

Profile (D side)

Profile (A side) See Pages 34-37

Drive Shaft Position: A, B, C or D

Idler Tail Type: 0 = Standard 60 mm (2.4 in), 5 = Nose Bar 16 mm (5/8 in)

V-Guide & Mounting Bracket Options:

1 = Non V-Guide belt, conveyor to include mounting brackets & return roller 4 = V-Guide belt, conveyor NOT to include mounting brackets & no return rollers

2 = V-Guide belt, conveyor to include mounting brackets & return rollers 5 = Non V-Guide belt, conveyor NOT to include mounting brackets, with return rollers

3 = Non V-Guide belt, conveyor NOT to include mounting brackets & no return rollers 6 = V-Guide belt, conveyor NOT to include mounting brackets, with return rollers

Conveyor Length Reference: 0170 to 2400 in 0001 foot increments

Conveyor Width Reference: 8 to 36 in inches

Documentation Language: M = US English, U = Europe English, D = German, F = French, S = Spanish

Prefix: 2L = 2700 Series Belted, ED = End Drive Flat Belt

\* Conveyor load capacity depends on conveyor size, incline, motor position, accumulated loads and other factors.

Order gearmotor mounting packages and gearmotors separately, see pages 73-78  
For support stands and accessories, see pages 90-95

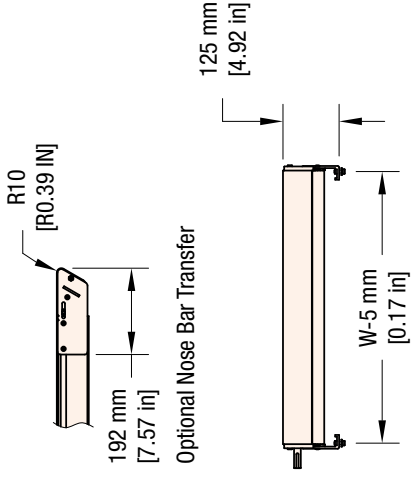
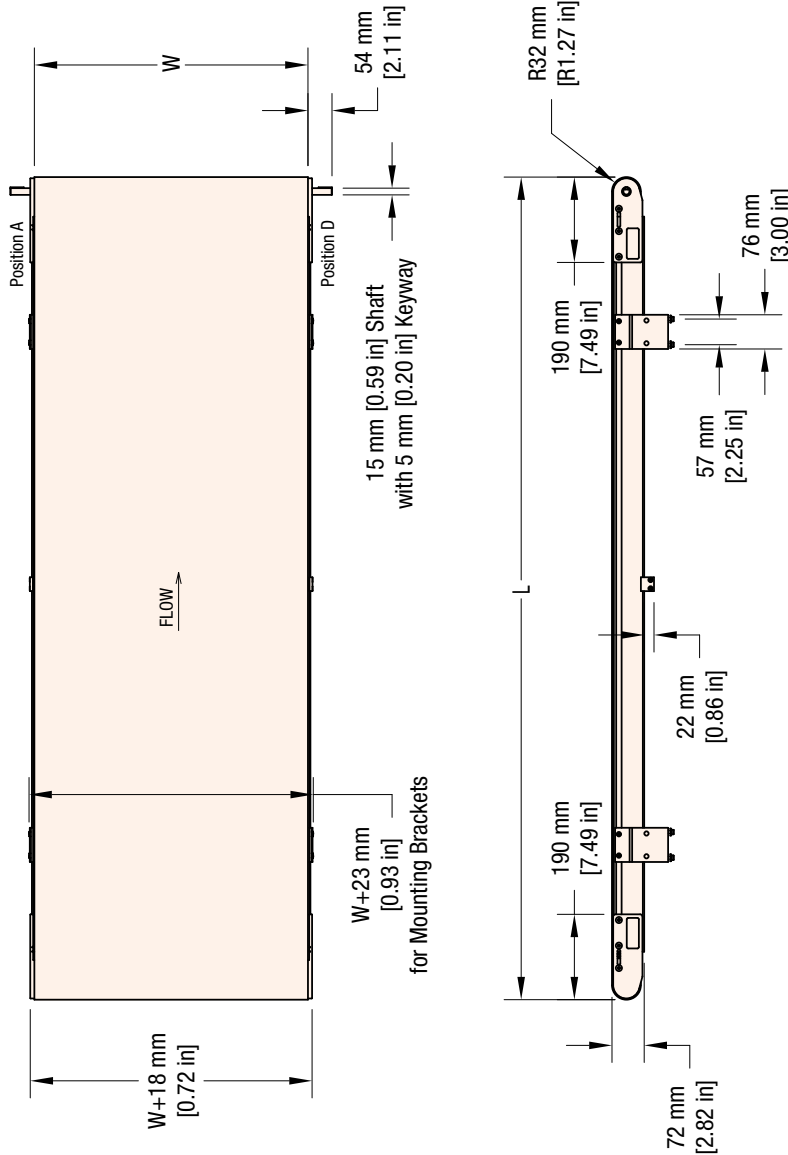
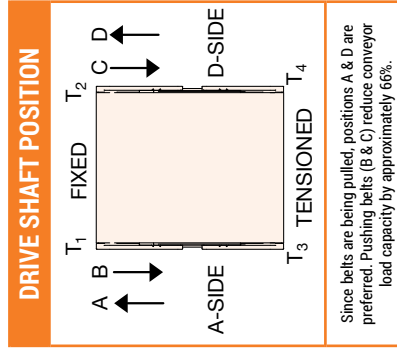

W = Conveyor Belt Width Dim = mm (in)

STANDARD SIZES															
Conveyor Width Reference	08	10	12	14	16	18	20	22	24	26	28	30	32	34	36
Conveyor Belt Width (W)	203 mm (8 in)	254 mm (10 in)	305 mm (12 in)	356 mm (14 in)	406 mm (16 in)	457 mm (18 in)	508 mm (20 in)	559 mm (22 in)	610 mm (24 in)	660 mm (26 in)	711 mm (28 in)	762 mm (30 in)	813 mm (32 in)	864 mm (34 in)	914 mm (36 in)
Conveyor Length Reference	0170														
Conveyor Length (L)	508 mm (1.7 ft)														
													0001 increments up to...		
													3 mm (0.12 in) increments up to...		
													2400		
													7,315 mm (24 ft)		

NOTE: Conveyor longer than 3,658 mm (12 ft) will be constructed using two equal length frames.  
 \*NOTE: Max length varies based on tail section.



## Specifications

- Loads up to 68 kg (150 lbs)\*
- Belt speeds up to 122 m/min (400 ft/min)
- Belt widths: 203 to 914 mm (8 to 36 in)
- Conveyor lengths: 610 to 7315 mm (24 in to 24 ft)
- 60 mm (2.4 in) diameter drive and idler pulleys turn approximately 189 mm (7.4 in) of belt per revolution
- V-groove bedplate with guided belt provides belt tracking, even under demanding side load applications
  - Cam tracking standard on Non V-Guided belt conveyors
- 15 mm diameter integral drive shaft with auxiliary shaft location options



### OPTIONAL: 16 mm (5/8 in) High Speed Nose Bar Transfer Tail

Available at non-driven end.  
V-guide supported.  
Speeds up to 61 m/min (200 ft/min)



### STANDARD FEATURE: Rack and Pinion

Allows the tail section to be easily  
slid back for quick belt adjustments  
and removal

#### 2700 Series Flat Belt Mid Drive Conveyor

2 L M D M W W - L L L L 1 0 0 A P P P P B B - X T<sup>1</sup> T<sup>2</sup> T<sup>3</sup> T<sup>4</sup>

— Conveyor Tail Options X (if required) 0 = No Shaft, K = Keyed Auxiliary Shaft

— Belt Type See Note

— Profile (D side)

— Profile (A side) See Pages 34-37

— Shaft Position: A = A side, D = D side, E = Both sides

— Tension Tail Type: 0 = Standard 60 mm (2.4 in), 5 = Nose Bar 16 mm (5/8 in)

— Fixed Tail Type: 0 = Standard 60 mm (2.4 in), 5 = Nose Bar 16 mm (5/8 in)

— V-Guide & Mounting Bracket Options:

1 = Non V-Guide belt, conveyor to include mounting brackets & return roller

4 = V-Guide belt, conveyor NOT to include mounting brackets & no return rollers

2 = V-Guide belt, conveyor to include mounting brackets & return rollers

5 = Non V-Guide belt, conveyor NOT to include mounting brackets, with return rollers

3 = Non V-Guide belt, conveyor NOT to include mounting brackets & no return rollers

6 = V-Guide belt, conveyor NOT to include mounting brackets, with return rollers

— Conveyor Length Reference: 0200 to 2400 in 0001 ft increments

— Conveyor Width Reference: 8 to 36 in inches

— Documentation Language: M = US English, U = Europe English, D = German, F = French, S = Spanish

— Prefix: 2L = 2700 Series Belted, MD = Mid Drive Flat Belt

\* Conveyor load capacity depends on conveyor size, incline, motor position, accumulated loads and other factors.

Order gearmotor mounting packages and gearmotors separately, see pages 73-78  
For support stands and accessories, see pages 90-95

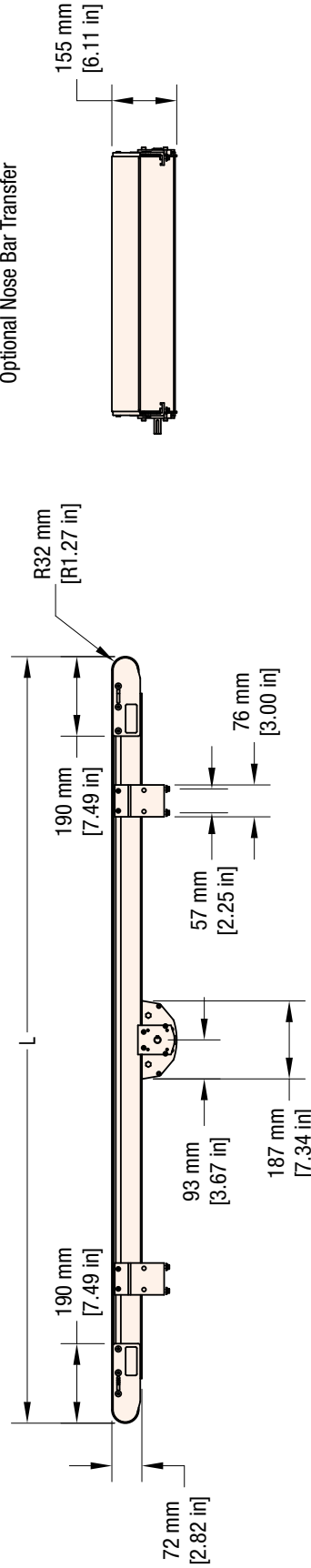
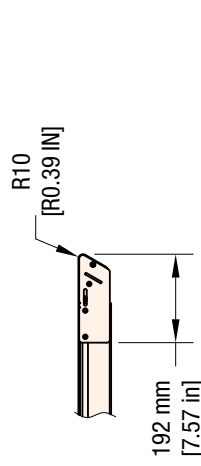
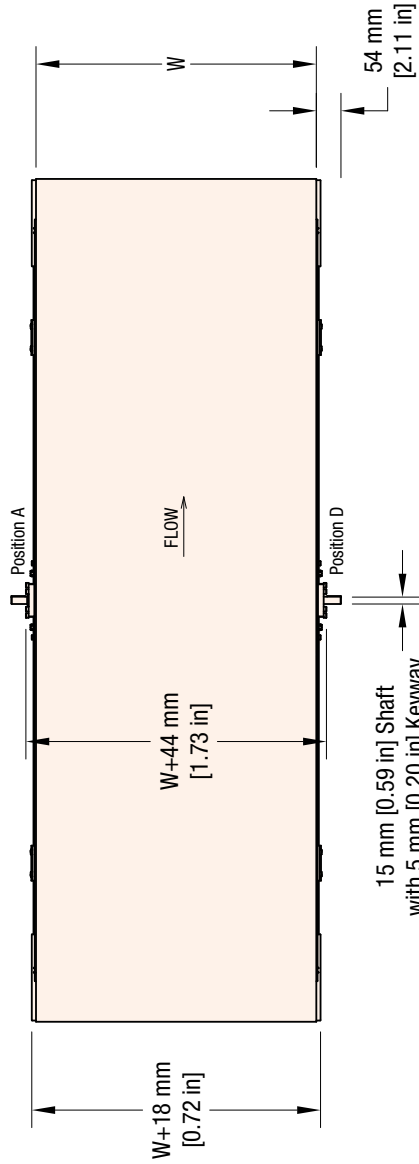
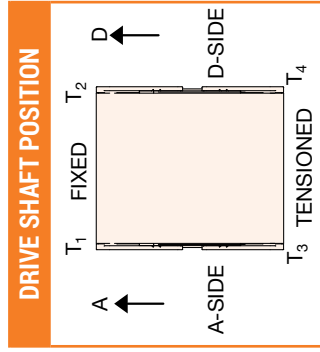

W = Conveyor Belt Width Dim = mm (in)

STANDARD SIZES															
Conveyor Width Reference	08	10	12	14	16	18	20	22	24	26	28	30	32	34	36
Conveyor Belt Width (W)	203 mm (8 in)	254 mm (10 in)	305 mm (12 in)	356 mm (14 in)	406 mm (16 in)	457 mm (18 in)	508 mm (20 in)	559 mm (22 in)	610 mm (24 in)	660 mm (26 in)	711 mm (28 in)	762 mm (30 in)	813 mm (32 in)	864 mm (34 in)	914 mm (36 in)
Conveyor Length Reference	0200														
Conveyor Length (L)	610 mm (2.0 ft)														
	0001 increments up to...														
	2400														
	7,315 mm (24 ft)														

\*NOTE: Max length varies based on tail section.



## Specifications

- Conveyor Load Capacity (non-accumulated, distributed load):
  - 10 m/min (33 ft/min) – Up to 75 kg (165 lbs)
  - 15 m/min (49 ft/min) – Up to 49 kg (108 lbs)
  - 20 m/min (66 ft/min) – Up to 34 kg (75 lbs)
  - 25 m/min (82 ft/min) – Up to 27 kg (59 lbs)
  - 45 m/min (148 ft/min) – Up to 12 kg (26 lbs)
  - 61 m/min (200 ft/min) – Up to 7 kg (15 lbs)
- Belt Speeds: Variable Speed, (6) Speed Options
  - 1 to 10 m/min (3.3 to 33 ft/min)
  - 1.5 to 15 m/min (4.9 to 49 ft/min)
  - 2 to 20 m/min (6.6 to 66 ft/min)
  - 2.5 to 25 m/min (8.2 to 82 ft/min)
  - 4.5 to 45 m/min (14.8 to 148 ft/min)
  - 6.1 to 61 m/min (20 to 200 ft/min)
- Belt Widths: 245 to 914 mm (10 to 36 in)
- Conveyor Lengths: 508 to 2940 mm (20 in to 10 ft)
- V-groove bedplate with guided belt provides belt tracking, even under demanding side load applications
  - Cam tracking standard on Non V-Guided belt conveyors
- Indexing Capable – Up to 30 indexes per minute
- iDrive2 Controls: 3 control options available
  - **Keypad Control:** Includes electrical box with speed and direction control switches, compact NEMA1 control box can be mounted directly on to conveyor via T-Slot, 115VAC power supply is optional.
  - **Remote Switch Control:** Includes electrical box with cable grip for control wiring, compact NEMA1 control box can be mounted directly on to conveyor via T-Slot, 115VAC power supply is optional.
  - **Drive Controller only:** Includes motor controller to be mounted by others in centralized control box, no power supply is available for this option

### 2700 Series Flat Belt End Drive iDrive2 Conveyor

2	L	E	D	M	W	W	-	L	L	L	L	1	0	A	P	P	P	P	B	B	-	F	D	F	P	B
<p>– Speed Range: A = 201 FPM, B = 147 FPM, C = 120 FPM, D = 82 FPM, E = 67 FPM, F = 49 FPM, G = 33 FPM</p> <p>– Power Supply: P = Power Supply (115V) included, N = No power supply included</p> <p>– Control Type: F = Two speed &amp; on/off conveyor mounted control R = Mounted controller with remote switched control C = Controller only for customer mounting and switching</p> <p>– Integrated Frame Drive: FD = Integrated Frame Drive</p> <p>– Belt Type See Note</p> <p>– Profile (D side)</p> <p>– Profile (A side) See Pages 34-37</p> <p>– Drive Shaft Position: A, B, C or D</p> <p>– Idler Tail Type: 0 = Standard 60 mm (2.4 in), 5 = Nose Bar 16 mm (5/8 in)</p> <p>– V-Guide &amp; Mounting Bracket Options:</p> <p>1 = Non V-Guide belt, conveyor to include mounting brackets &amp; return roller    4 = V-Guide belt, conveyor NOT to include mounting brackets &amp; no return rollers</p> <p>2 = V-Guide belt, conveyor to include mounting brackets &amp; return rollers    5 = Non V-Guide belt, conveyor NOT to include mounting brackets, with return rollers</p> <p>3 = Non V-Guide belt, conveyor NOT to include mounting brackets &amp; no return rollers    6 = V-Guide belt, conveyor NOT to include mounting brackets, with return rollers</p> <p>– Conveyor Length Reference: 0170 to 1000 in 0001 foot increments</p> <p>– Conveyor Width Reference: 10 to 36 in inches</p> <p>– Documentation Language: M = US English, U = Europe English, D = German, F = French, S = Spanish</p> <p>– Prefix: 2L = 2700 Series Belted, ED = End Drive Flat Belt</p>																										

\* Conveyor load capacity depends on conveyor size, incline, motor position, accumulated loads and other factors.

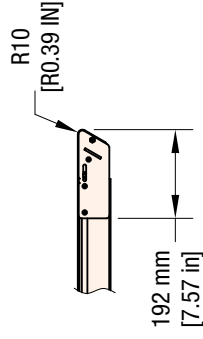
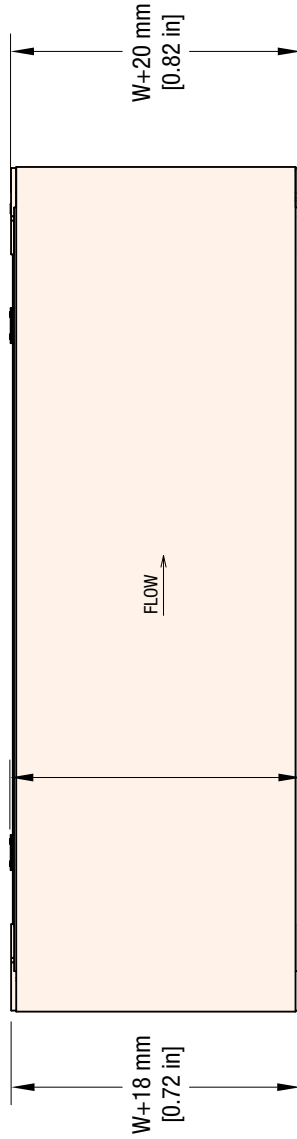
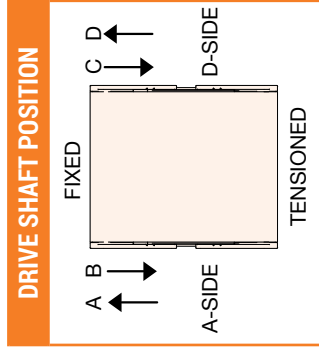

Optional Nose Bar Transfer

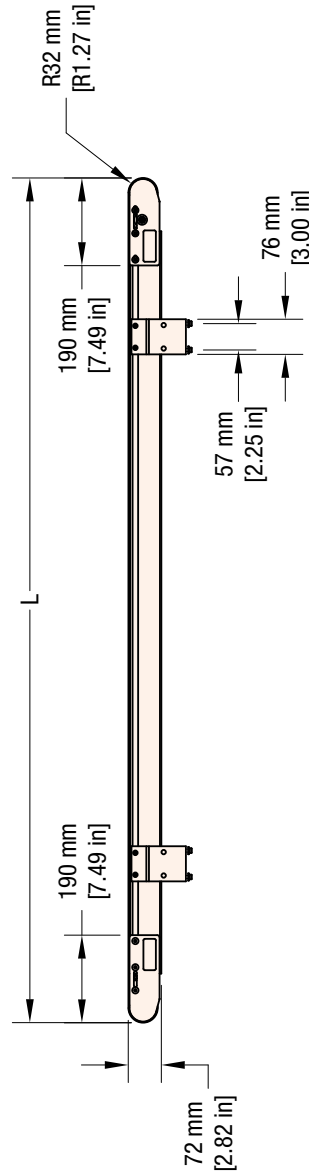
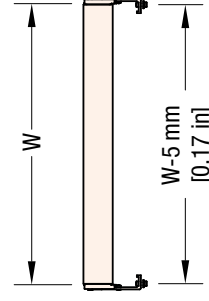

W = Conveyor Belt Width Dim = mm (in)

STANDARD SIZES														
Conveyor Width Reference	10	12	14	16	18	20	22	24	26	28	30	32	34	36
Conveyor Belt Width (W)	254 mm (10 in)	305 mm (12 in)	356 mm (14 in)	406 mm (16 in)	457 mm (18 in)	508 mm (20 in)	559 mm (22 in)	610 mm (24 in)	660 mm (26 in)	711 mm (28 in)	762 mm (30 in)	813 mm (32 in)	864 mm (34 in)	914 mm (36 in)
Conveyor Length Reference	0170												1000	
Conveyor Length (L)	508 mm (1.7 ft)												3,048 mm (10 ft)	

0001 increments up to...

3 mm (0.12 in) increments up to...

NOTE: Conveyor longer than 3,658 mm (12 ft) will be constructed using two equal length frames.  
 \*NOTE: Max length varies based on tail section.

# 2200 SERIES PRECISION MOVE FLAT & CLEATED BELT END DRIVE

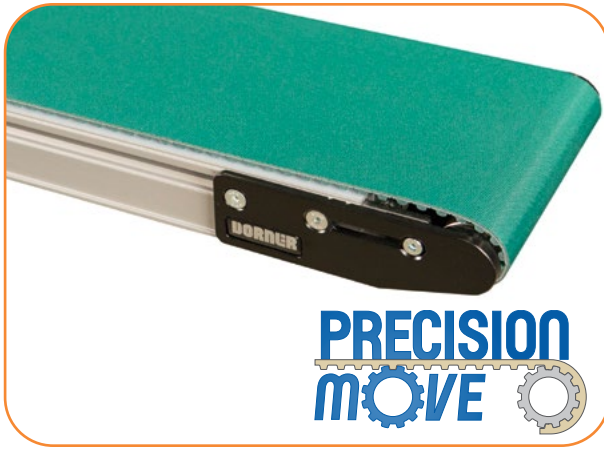

## Specifications

- Loads up to 91 kg (200 lbs)\*
- Belt speeds up to 113 m/min (370 ft/min)
- Belt widths: 25 to 610 mm (1 to 24 in)
- Conveyor lengths: 457 to 9,144 mm (18 in to 30 ft)
- 38 mm (1.5 in) pitch diameter drive pulley turns approximately 121 mm (4.7 in) of belt per revolution
- T10 profile cogged belt with 12 tooth drive pulley
- Conveyor mechanical accuracy  $\pm 0.5$  mm ( $\pm 0.02$  in)
- Conveyor package w/servo motor index accuracy  $\pm 1$  mm ( $\pm 0.04$  in)
- 12 mm diameter integral drive shaft
- Reverse V-Guide provides positive belt tracking, even under demanding side load applications



### STANDARD FEATURE: Reverse V-Guide

Provides positive tracking along the entire length of the conveyor



### Positive Drive Belting

Positivity driven belt ensures belt does not slip and allows for higher load capacity



### OPTIONAL: 3 Cleat Heights Available (20 mm, 36 mm, or 52 mm)

#### 2200 Series Precision Move Flat Belt End Drive Conveyor

22	PM	M	WW	-	LLLL	1	A	PP	PP	BB	-	X	T <sup>1</sup>	T <sup>2</sup>	T <sup>3</sup>	T <sup>4</sup>	
												Conveyor Tail Options X (if required)					
												A or B = Drive Shaft (T <sup>1</sup> only)		C or D = Drive Shaft (T <sup>2</sup> only)		S = Stub Shaft	
												O = No Shaft				K = Keyed Auxiliary Shaft	
												Belt Type					
												Profile (D side)					
												Profile (A side)					
												Flow/Drive Shaft Position: A, B, C or D					
												Return Roller & Mounting Bracket Options: 2 = V-Guided Belt, includes mounting brackets and return rollers					
												4 = V-Guided Belt, without mounting brackets and return rollers					
												6 = V-Guided Belt, without mounting brackets, includes return rollers					
												Conveyor Length Reference: L.L.L.L in feet					
												Conveyor Width Reference					
												Documentation Language: M = US, U = Europe					

#### 2200 Series Precision Move Cleated Belt End Drive Conveyor

22	PM	M	WW	-	LLLL	1	A	PP	A	3	SSSS	-	X	T <sup>1</sup>	T <sup>2</sup>	T <sup>3</sup>	T <sup>4</sup>
												Conveyor Tail Options X (if required) *See Drive Shaft Position Chart on next page					
												A or B = Drive Shaft (T <sup>1</sup> only)		C or D = Drive Shaft (T <sup>2</sup> only)		S = Stub Shaft	
												O = No Shaft				K = Keyed Auxiliary Shaft	
												Cleat Spacing: SS.SS in inches					
												Base Belt: 3 = High Friction					
												Cleat Height: A = 19 mm (.75 in), B = 35.6 mm (1.4 in), C = 50 mm (2 in)					
												Profile: 01 = Low Side, 02 = 25 mm (1 in) Cleated, 03 = 50 mm (2 in) Cleated					
												Flow/Drive Shaft Position: A, B, C or D					
												Return Roller & Mounting Bracket Options: 2 = V-Guided Belt, includes mounting brackets and return rollers					
												4 = V-Guided Belt, without mounting brackets and return rollers					
												6 = V-Guided Belt, without mounting brackets, includes return rollers					
												Conveyor Length Reference: L.L.L.L in feet					
												Conveyor Width Reference					
												Documentation Language: M = US, U = Europe					

\* Conveyor load capacity depends on conveyor size, incline, motor position, accumulated loads and other factors.

Order gearmotor mounting packages and gearmotors separately, see pages 73-78  
For support stands and accessories, see pages 90-95

# PRECISION MOVE FLAT & CLEATED BELT END DRIVE 2200 SERIES

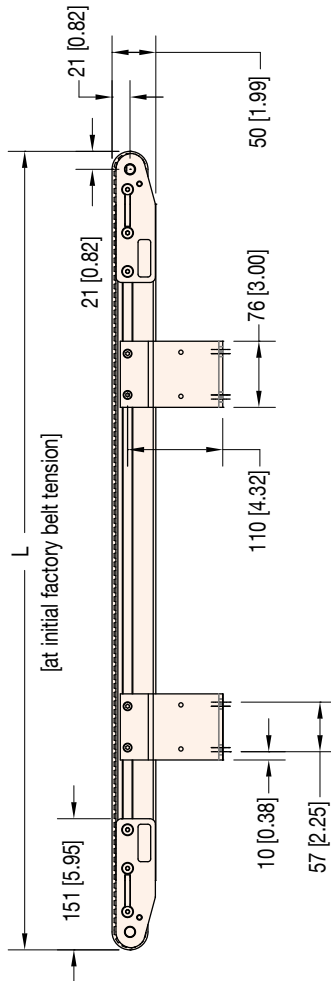
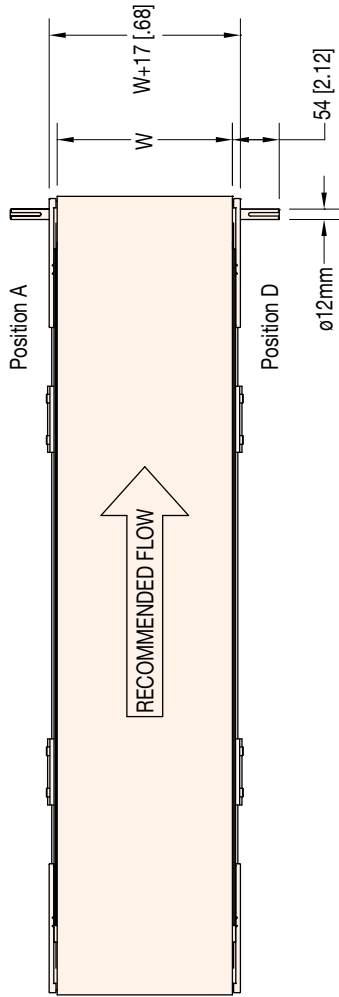
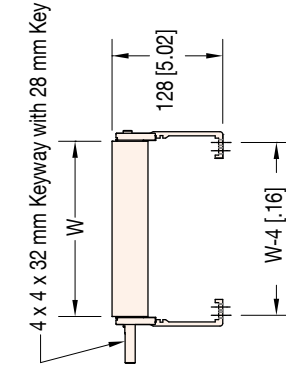
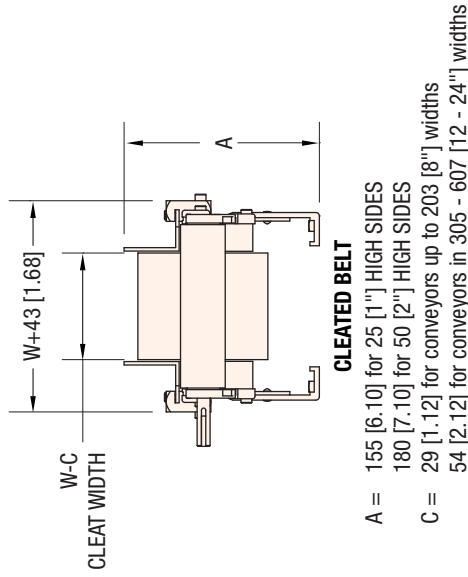

W = Conveyor Belt Width Dim = mm (in)

## STANDARDS

Conveyor Width Reference	01	02	03	04	06	08	12	18	24
Conveyor Belt Width (W)	25 mm (1 in)*	45 mm (1.75 in)	70 mm (2.75 in)	95 mm (3.75 in)	152 mm (6.0 in)	203 mm (8.0 in)	305 mm (12.0 in)	457 mm (18.0 in)	607 mm (24.0 in)
Conveyor Length Reference	0150		0001 increments up to...						
Conveyor Length	457 mm (1.5 ft)		2.54 mm (0.1 in) increments up to...						
			9,144 mm (30 ft)						

**NOTE:** Actual conveyor length may need to be adjusted to match belt pitch.

Conveyors longer than 305 to 457 mm (12.01 to 18.00 ft) will be constructed using two equal length frame sections.

Conveyors 5486 to 8229 mm (18.01 to 27.00 ft) in length will be constructed using three equal length frame sections.

Conveyors 8229 to 9144 (27.01 to 30.00 ft) in length will be constructed using four equal length frame sections.

\*Cleats not available for 25 mm (1 in) wide Precision Move Conveyors.

## DRIVE SHAFT POSITION

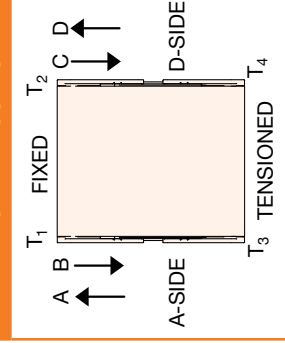

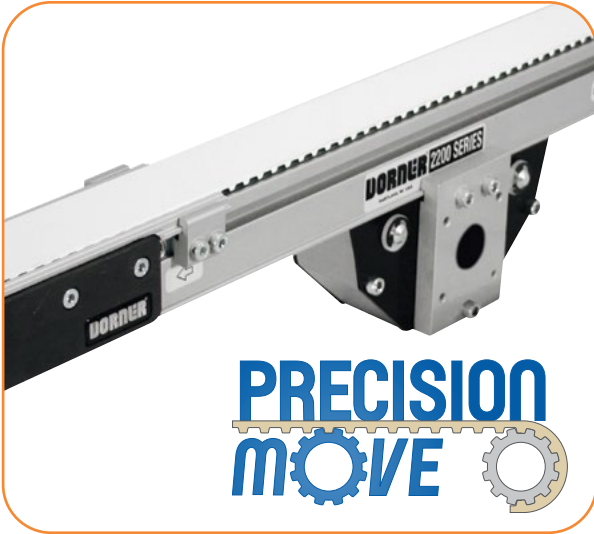

## Specifications

- Loads up to 91 kg (200 lbs)\*
- Belt speeds up to 113 m/min (370 ft/min)
- Belt widths: 25 to 610 mm to (1 to 24 in)
- Conveyor lengths: 18" (457 mm) to 30' (9,144 mm)
- 51 mm (2 in) pitch diameter drive pulley turns approximately 160 mm (6.3 in) of belt per revolution
- T10 profile cogged belt with 16 tooth drive pulley
- Conveyor mechanical accuracy  $\pm 0.5$  mm ( $\pm 0.02$  in)
- Drive shaft options:
  - 12 mm diameter integral drive shaft
  - 16 tooth 13 mm (0.5 in) diameter hollow spline drive
- Reverse V-Guide provides positive belt tracking, even under demanding side load applications



### STANDARD FEATURE: Reverse V-Guide

Provides positive tracking along the entire length of the conveyor



### Positive Drive Belting

Positively driven belt ensures belt does not slip and allows for higher load capacity

### 2200 Series Precision Move Flat Belt Mid Drive Conveyor

22	PD	M	W	W	-	L	L	L	L	L	1	A	P	P	P	P	B	B	-	X	T <sup>1</sup>	T <sup>2</sup>	T <sup>3</sup>	T <sup>4</sup>
																				Conveyor Tail Options X (if required) *See Drive Shaft Position Chart on next page				
																				O = No Shaft				
																				K = Keyed Auxiliary Shaft				
																				S = Stub Shaft				
																				Belt Type				
																				Profile (D side)				
																				Profile (A side)				
																				Mid Drive Shaft Position: A = A side, D = D side, E = Both side, G = Gang				
																				V-guide & Mounting Bracket Options:				
																				2 = V-Guided Belt, includes mounting brackets and return rollers				
																				4 = V-Guided Belt, without mounting brackets and return rollers				
																				6 = V-Guided Belt, without mounting brackets, includes return rollers				
																				Conveyor Length Reference: L.L.L.L in feet				
																				Conveyor Width Reference				
																				Documentation Language: M = US, U = Europe				

\* Conveyor load capacity depends on conveyor size, incline, motor position, accumulated loads and other factors.

Order gearmotor mounting packages and gearmotors separately, see pages 73-78  
For support stands and accessories, see pages 90-95

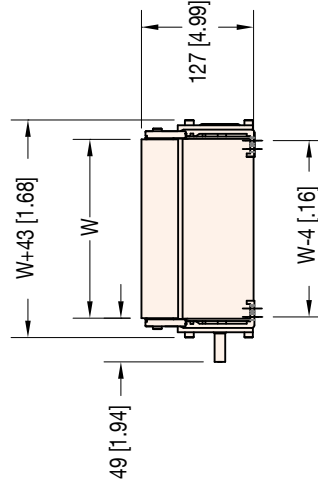
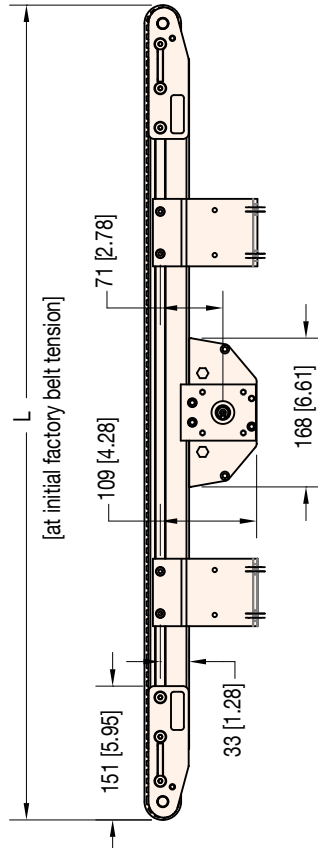
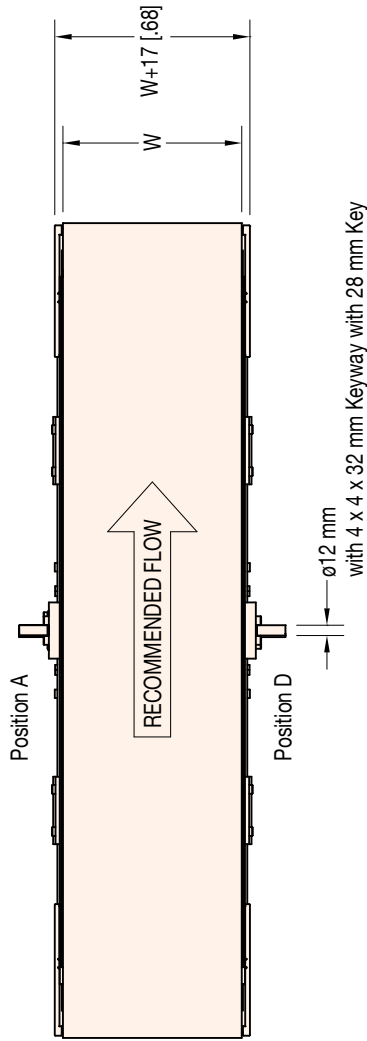

W = Conveyor Belt Width Dim = mm (in)

### STANDARD SIZES

Conveyor Width Reference	01	02	03	04	06	08	12	18	24
Conveyor Belt Width (W)	25 mm (1 in)	45 mm 1.75 in)	70 mm 2.75 in)	95 mm (3.75 in)	152 mm (6.0 in)	203 mm (8.0 in)	305 mm (12.0 in)	457 mm (18.0 in)	607 mm (24.0 in)
Conveyor Length Reference	0150		0001 increments up to...						
Conveyor Length	457 mm (1.5 ft)		2.54mm (0.1 in) increments up to... 9,144mm (30 ft)						

**NOTE:** Actual conveyor length may need to be adjusted to match belt pitch. Conveyors longer than 305 to 457 mm (12.01 to 18.00 ft) will be constructed using two equal length frame sections. Conveyors 5486 to 8229 mm (18.01 to 27.00 ft) in length will be constructed using three equal length frame sections. Conveyors 8229 to 9144 (27.01 to 30.00 ft) in length will be constructed using four equal length frame sections.

### DRIVE SHAFT POSITION

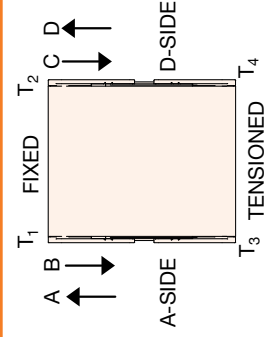

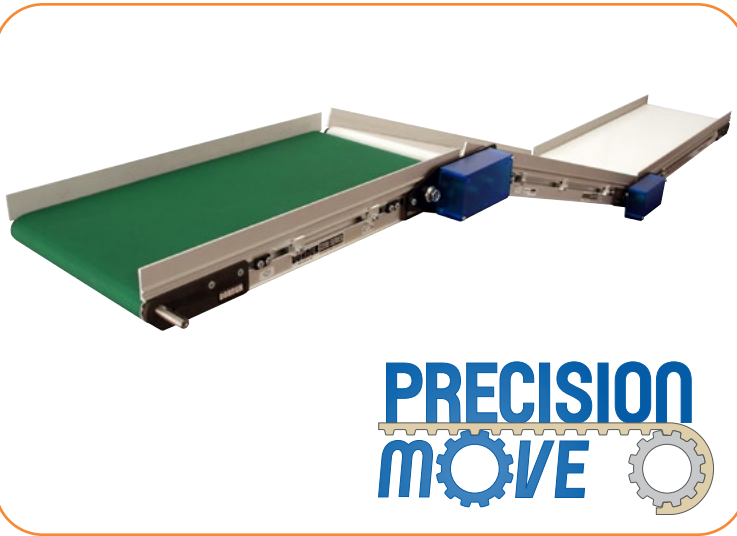

## Specifications

- Link multiple conveyors with 1 drive
- Adjustable angle from 0° to 25°
- Variety of timing belt ratios available
  - 1:1, 1.27:1, 1.75:1, 2:1 can be used to speed or slow down the conveyor
- Maximum number of conveyors = 3
- Pull or close gaps between product
- Change belt types on each conveyor
- Includes tie plates, pulley kit, tension adjustment and guard
- Utilize low, high friction belts, and/or multiple speeds in a single configuration
- Can not be used with cleated belt applications

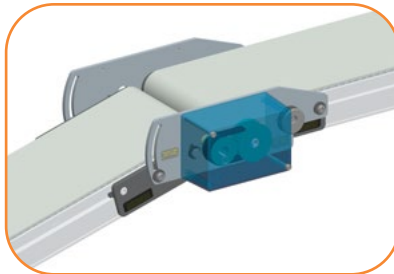

Part Number	Drive Teeth	Driven Teeth	Infeed Conveyor Speed Condition
202363-1632	16	32	2X Speed Up
202363-1628	16	28	1.75X Speed Up
202363-2228	22	28	1.27X Speed Up
202363-2222	22	22	Same Speed
202363-2822	28	22	0.78X Slow Down
202363-2816	28	16	0.57X Slow Down
202363-3216	32	16	2X Slow Down

### STANDARD FEATURE: Series Drive Kit

Includes tie plates for both sides of conveyor and timing belt / pulleys and guard

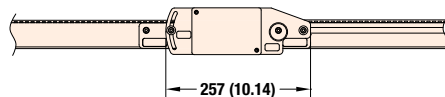
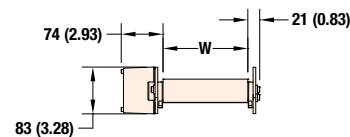
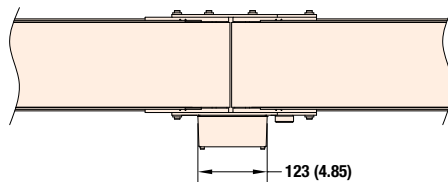

Dim = mm (in)

Due to the wide variety of drive set ups and applications, point of installation guarding is the responsibility of the end user.

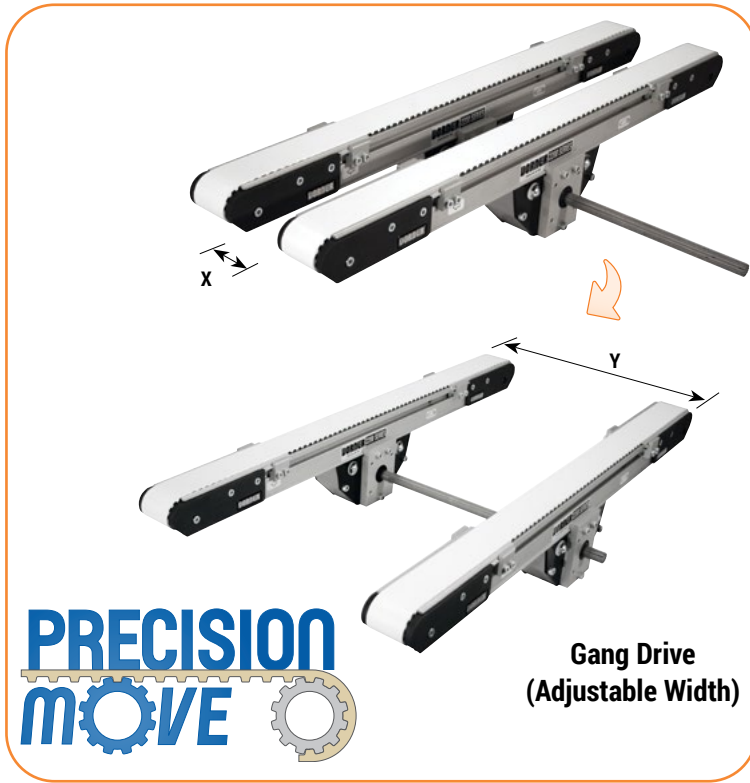

**Mid Drive Gang Driven Conveyors**

**Specifications**

- Adjustable for various product widths
- Drive moveable between tails
- Frees up ends of conveyor
- Conveyor center distances can be moved while conveyor is running
- Minimum width (x) = 101 mm (4 in) belt to belt (with std. guarding)
- Minimum width (x) = 45 mm (1.75 in) belt to belt without guarding (end user responsible for point of installation guarding)
- Maximum width (y) = 1,219 mm (48 in) belt to belt
- Maximum total torque = 9.0 Nm (80 in-lbs)
- Compatible with side mount gearmotor package
- Requires 13 mm (½ in) diameter 16 tooth spline drive shaft

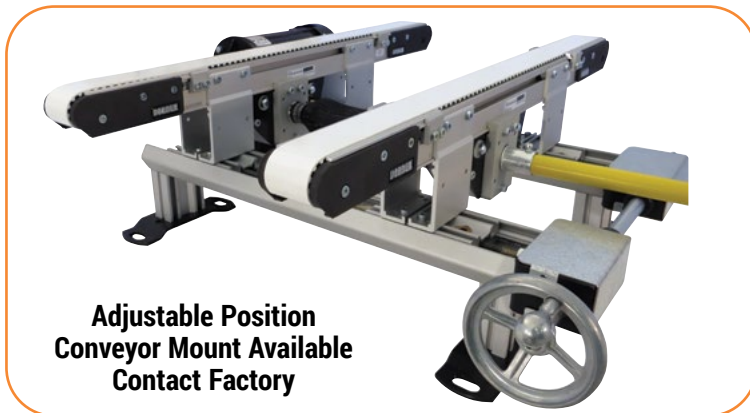

**Gang Driven Side Mount Package**

**Specifications**

- Compatible with all standard load and heavy load 90° gearmotors
- Conveyor position is adjustable along length of spline drive shaft
- Includes shafts, couplings, and expandable shaft guarding
- Mount package is attached to the first conveyor
- Maximum number of conveyors = 3
- Maximum total torque = 9.0 Nm (80 in-lbs)

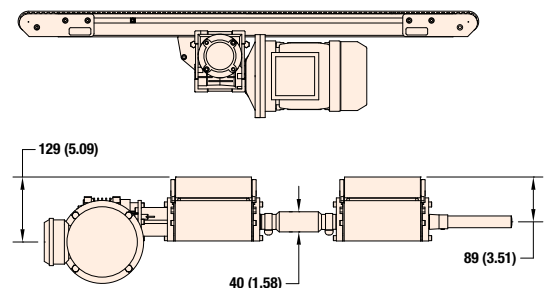
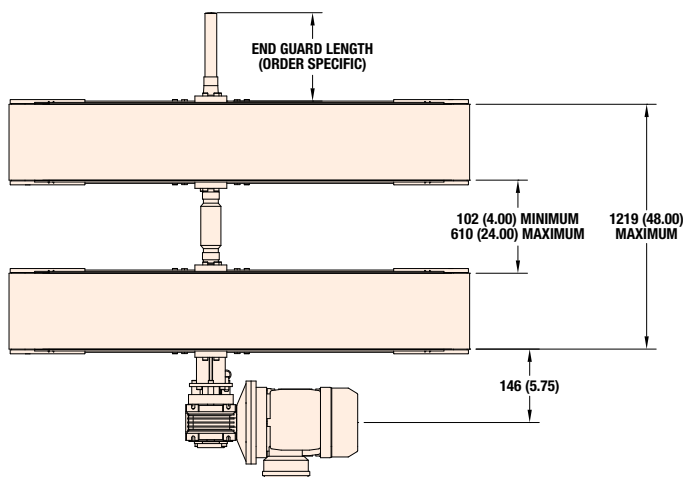

**Refer to page 55 for belt speed options.**  
 Due to the wide variety of drive set ups and applications, point of installation guarding is the responsibility of the end user.

Dim = mm (in)

## Precision Move Servo Gearmotor

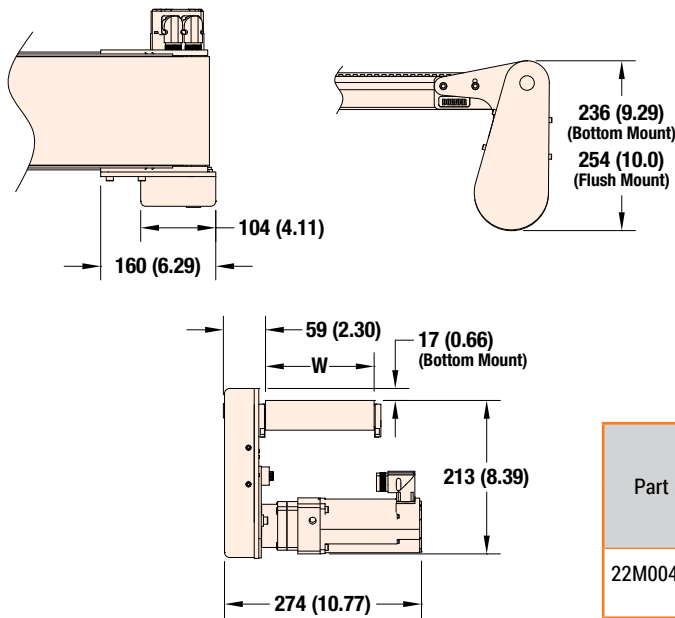
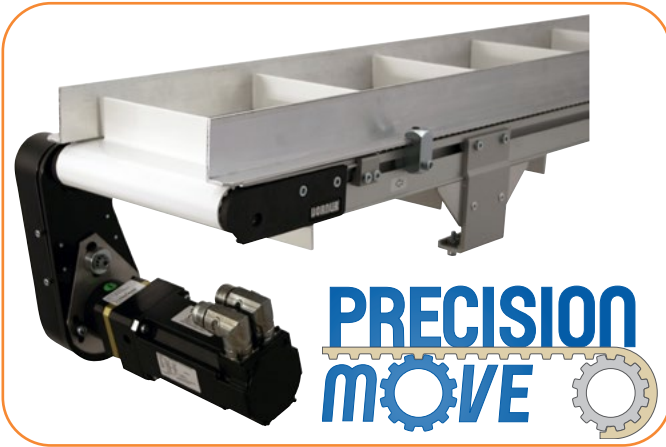

### Specifications

- Standard bottom and flush mount bottom drive configurations
- Indexes per minute rating = 100 per minute
- Conveyor/Drive Package Index accuracy =  $\pm 0.040$

### Motor:

- Kollmorgen AKM Series Motor
- Brushless DC Servo motor with encoder
- 80 mm Frame
- 1.02 kW
- Up to 640 VDC input
- Up to 2.62 amps
- Quick disconnect power and communication fittings
- UL, CE, RoHS Compliant

### Gearbox:

- Inline Planetary Reducer
- 4:1 Ratio
- 93% efficient
- 13 arc-minute backlash
- 20,000 hr rated
- RoHS compliant

Part Number	Controller Voltage	Max Belt Speed (Ft/min)		Min Belt Speed (Ft/min)	Torque (in-lb)	RPM
		Bottom Mount	Flush Mount			
22M004PR2B1KW	115V input	166	253	10	79	325
	230V input	276	420	10	79	625



## Precision Move Servo Bottom and Flush Mount Package

### Specifications

- Capable of standard bottom mount position and flush mount for wide product handling
- Includes rack and pinion timing belt tension system allowing reversing capability
- Includes high strength timing belt drive pulleys

### Servo Gearmotor or Reducer Only

Description	Part Number	Gearmotor Pulley	Conveyor Pulley
Bottom Mount	202436-A*	36 tooth	32 tooth
Flush Mount	202437-A*	36 tooth	21 tooth

\*A = Mount position (A, B, C, D)

Dim = mm (in)

Due to the wide variety of drive set ups and applications, point of installation guarding is the responsibility of the end user.

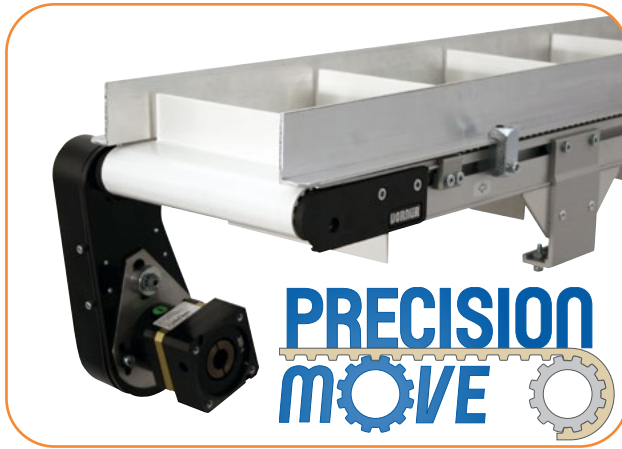

Precision Move Servo Gearhead Only

Specifications

- Offered as mount package and gearhead only
- Inline planetary reducer
- 3:1, 4:1, 5:1, 7:1, and 10:1 ratios available
- 93% efficient
- 13 arc-minute backlash
- 20,000 hr rated
- RoHS compliant

Gear Reducer for Customer Specified Motor

Generalized Sizes						
Shaft Diameter		Shaft Length		Bolt Circle		Pilot Diameter
Min	Max	Min	Max	Min	Max	Max
6 (0.24)	14 (0.55)	17 (0.67)	39 (1.54)	60 (2.36)	105 (4.13)	80 (3.15)

Dim: mm (in)

NOTE: These are generalized guidelines for mating adapters. Consult DTools or customer service to identify proper adapter for given motor.

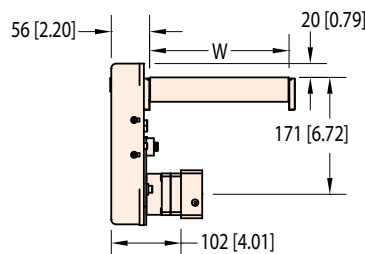
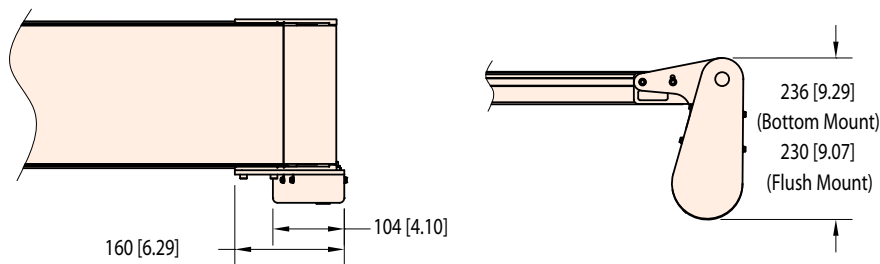
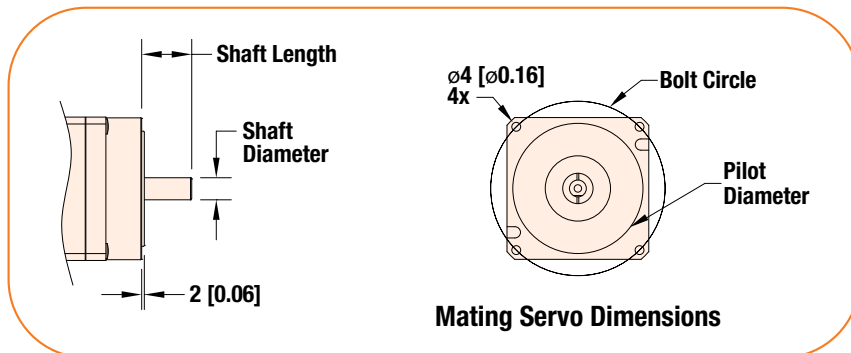

Dim = mm (in)

Due to the wide variety of drive set ups and applications, point of installation guarding is the responsibility of the end user.

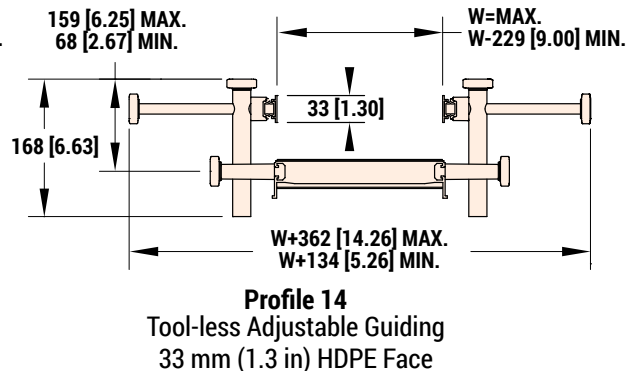
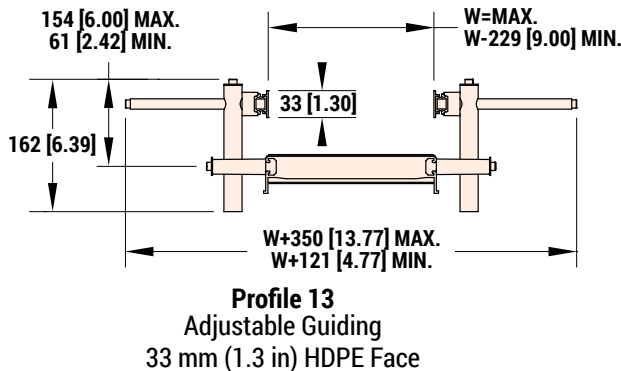
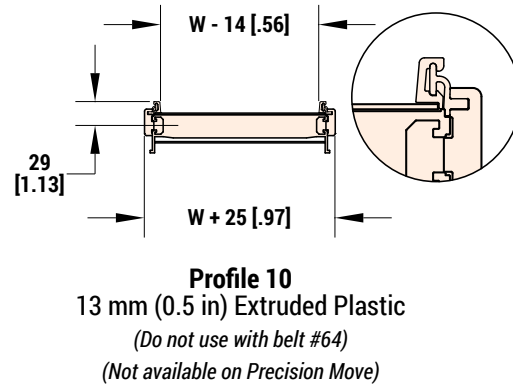
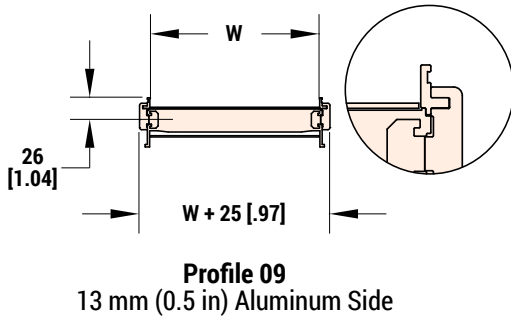
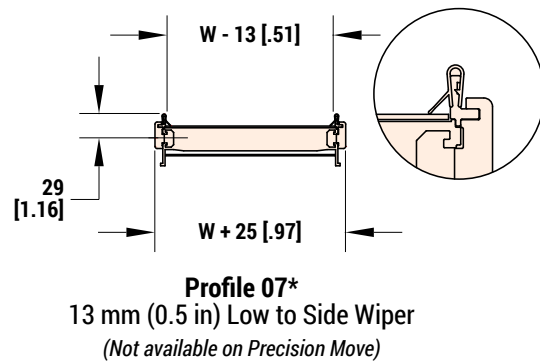
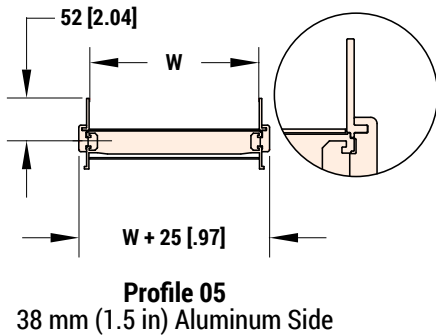
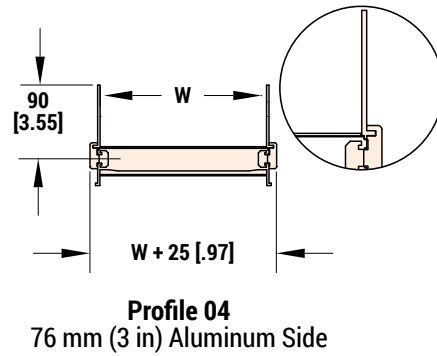
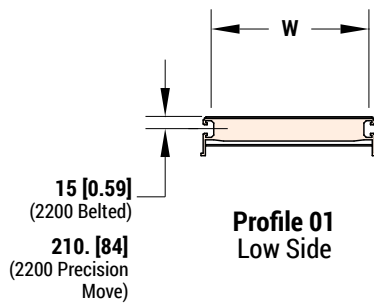

\* = Not available on Gravity Roller Conveyors and do not use with high friction belts

W = Conveyor Belt Width Dim = mm (in)

Due to the wide variety of drive set ups and applications, point of installation guarding is the responsibility of the end user.

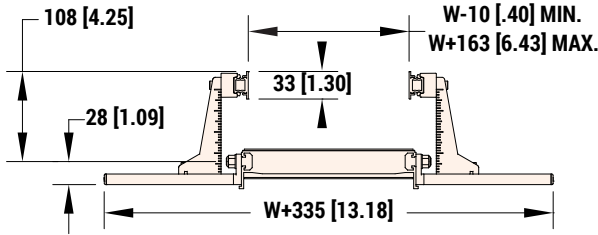

**Profile 16**  
Outboard Adjustable Guiding  
33 mm (1.3 in) HDPE Face

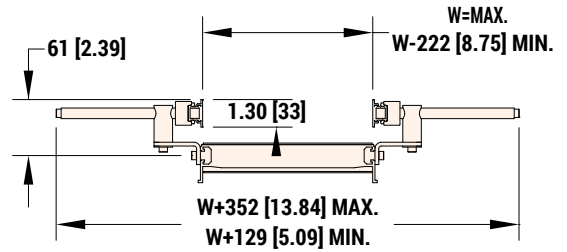

**Profile 19**  
Horizontal Adjustable Guiding  
33 mm (1.3 in) HDPE Face

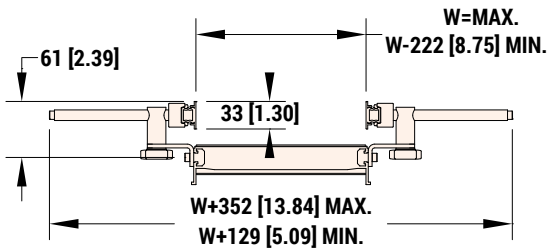

**Profile 20**  
Tool-less Horizontal Adjustable Guiding  
33 mm (1.3 in) HDPE Face

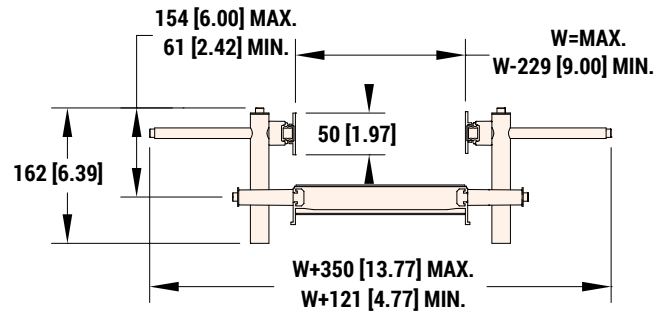

**Profile 33**  
Adjustable Guiding  
50 mm (2 in) HDPE Face

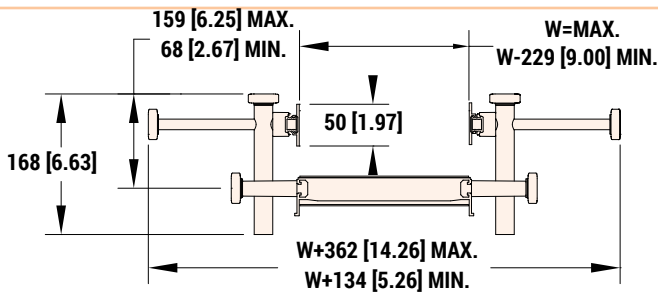

**Profile 34**  
Tool-less Adjustable Guiding  
50 mm (2 in) HDPE Face

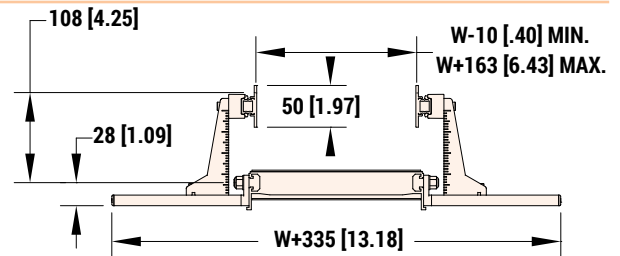

**Profile 36**  
Outboard Adjustable Guiding  
50 mm (2 in) HDPE Face

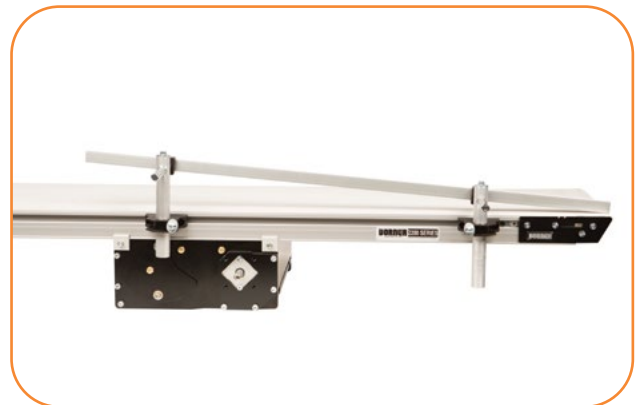

**Profile 13 Flat Belt - Adjustable Guiding**

W = Conveyor Belt Width Dim = mm (in)

Due to the wide variety of drive set ups and applications, point of installation guarding is the responsibility of the end user.

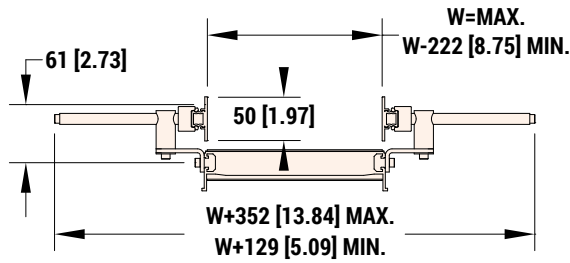

**Profile 39**  
Horizontal Adjustable Guiding  
50 mm (2 in) HDPE Face

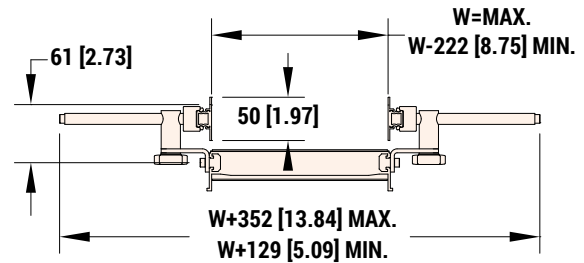

**Profile 40**  
Tool-less Horizontal Adjustable Guiding  
50 mm (2 in) HDPE Face

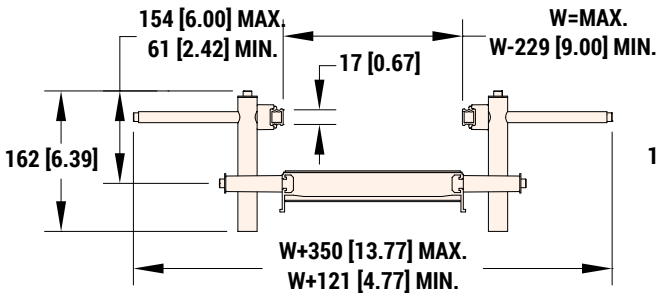

**Profile 43**  
Adjustable Guiding  
Aluminum Face

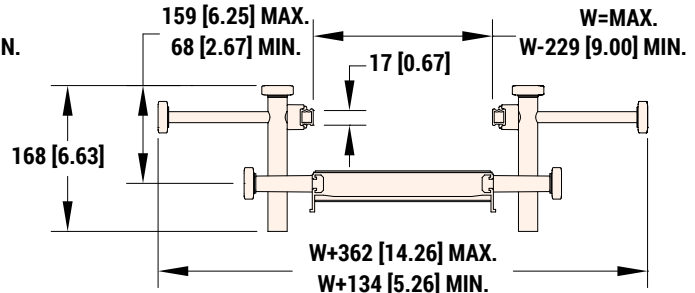

**Profile 44**  
Tool-less Adjustable Guiding  
Aluminum Face

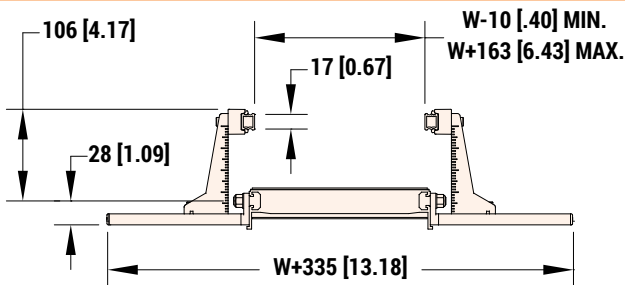

**Profile 46**  
Outboard Adjustable Guiding  
Aluminum Face

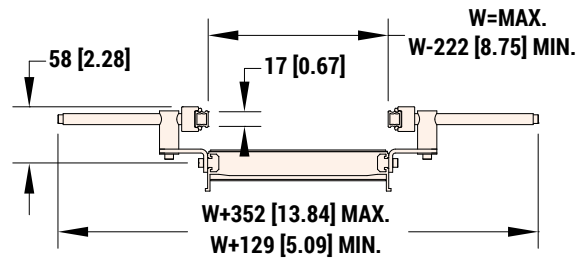

**Profile 49**  
Horizontal Adjustable Guiding  
Aluminum Face

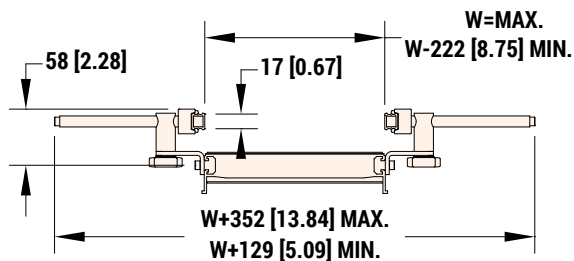

**Profile 50**  
Tool-less Horizontal Adjustable Guiding  
Aluminum Face

W = Conveyor Belt Width Dim = mm (in)

Due to the wide variety of drive set ups and applications, point of installation guarding is the responsibility of the end user.

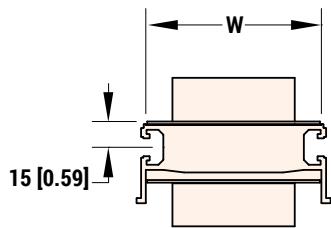

**Cleated Profile 0**  
Low Side Cleated

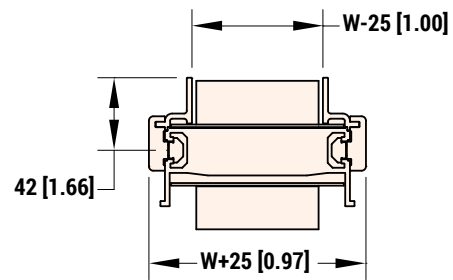

**Cleated Profile 2/4**  
25 mm (1 in) Aluminum Side  
**Note:** Profile 2 is cut 45 degree on both end - for reversing applications  
Profile 4 is cut 45 degree on infeed end, 90 degree on discharge

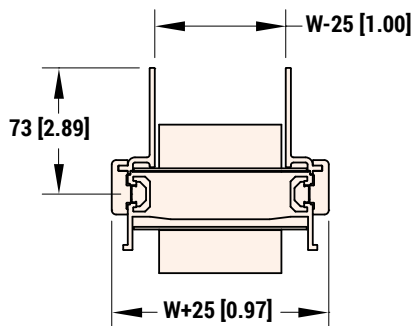

**Cleated Profile 3/5**  
64 mm (2.5 in) Aluminum Side  
**Note:** Profile 3 is cut 45 degree on both end - for reversing applications  
Profile 5 is cut 45 degree on infeed end, 90 degree on discharge

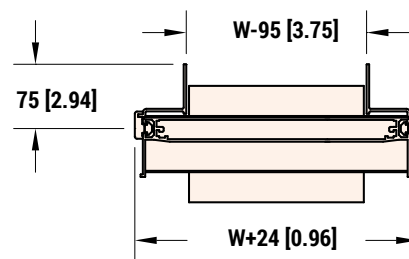

**Cleated LPZ Profile 3**  
64 mm (2.5 in) Aluminum Side



**Profile 04 Flat Belt - Aluminum Side**



**Profile 3 Cleated LPZ - Aluminum Side**

**W** = Conveyor Belt Width    **Dim** = mm (in)

*Due to the wide variety of drive set ups and applications, point of installation guarding is the responsibility of the end user.*



## Standard Belt Selection Guide

Standard belt material is stocked at Dorner, then cut & spliced at the factory for fast conveyor shipment.

Belt Type - Finger Splice	Belt Type - Plastic Clipper	Belt Type - Metal Clipper	Belt Specifications	V-Guidable	8 mm (5/16 in) Nose Bar	16 mm (5/8 in) Nose Bar	Belt Thickness	Surface Material	Maximum Part Temperature	Coefficient of Friction	FDA Approved	Anti-Static	ESD	Chemical Resistance	Special Characteristics or Applications
01	A1	1A	FDA Accumulation	x			1.7 (0.067)	Urethane	212°F (100°C)	Low	x	x		Good	Packaging, clean room and inspection
02	A2	2A	General Purpose	x			1.8 (0.071)	Urethane	212°F (100°C)	Med	x	x		Good	Most versatile belt offering
03	A3	3A	FDA High Friction	x			1.7 (0.067)	Urethane	212°F (100°C)	High	x	x		Good	Packaging, clean room and inspection
05	A5	5A	Accumulation	x	x		1.2 (0.047)	Urethane	212°F (100°C)	V-Low	x	x		Good	Accumulation of products
06	A6	6A	Static Dissipative	x			1.6 (0.063)	Urethane	176°F (80°C)	V-Low		x	x	Good	Electronics Handling
08	A8	8A	High Friction	x			2.1 (0.083)	PVC	158°F (70°C)	V-High		x		Poor	Conveys up to 35° inclines*
09			iDrive General Purpose	x		x	1.5 (0.059)	Urethane	212°F (100°C)	High	x			Good	Lower No Load Torque

Dim = mm (in)

**Note:** See below for splice details. Plastic Clipper splice requires longer lead times. Clipper splice not available on Z-Frame Series Conveyors.

**Note:** Belts with V-Guiding may have a slight high spot or rib on the top surface. This rib would run longitudinally along the center of the belt. Consult factory with applications for which this may cause interference.

\*Incline varies due to factors like dust, fluids and part material.

## BELT SPLICING

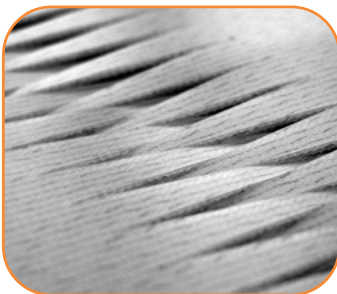

### Finger Splice

All belts are available with a standard Thermoformed finger splice. This splice makes the belt continuous and is virtually undetectable. Splice bonding methods vary by belt type. Consult factory for details.

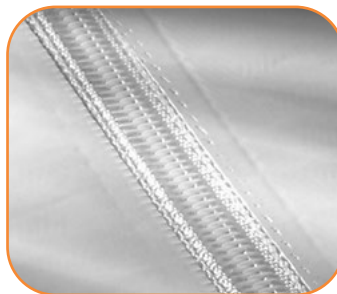

### Plastic Clipper\*\*

An optional plastic clipper splice is available for quick removal of belts or when conveyors are installed in tight spaces.

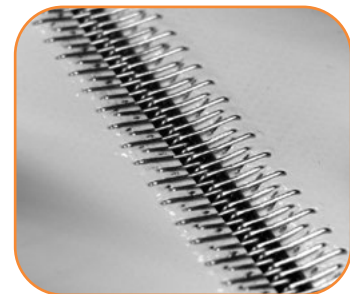

### Metal Clipper\*\*

An optional metal clipper splice is also available for quick removal of belts or when conveyors are installed in tight spaces.

\*\* See belt charts for compatibility. Not for use with 2200 Series Nose Bar Transfers. Plastic and Metal Clippers are slightly thicker than base belt. Contact factory for details.



## Specialty Belt Selection Guide

*Specialty belt material is not stocked at Dorner and needs to be custom ordered for your special conveyor needs.*

Belt Type - Finger Splice	Belt Type - Plastic Clipper	Belt Type - Metal Clipper	Belt Specifications	V-Guideable	8 mm (5/16 in) Nose Bar	16 mm (5/8 in) Nose Bar	Belt Thickness	Surface Material	Maximum Part Temperature	Coefficient of Friction	FDA Approved	Anti-Static	Static Conductive	Chemical Resistance	Special Characteristics or Applications
19			Nose bar High friction	x	x		0.7 (0.03)	Urethane	212°F (100°C)	High	x	x		Good	8 mm (5/16 in) Nose bar, high friction
50			Heat Resistant				1.3 (0.05)	Silicone	356°F (180°C)	Low		x		V-Good	High temperature
53			Translucent	x	x		0.02 (0.5)	Urethane	212°F (100°C)	V-Low	x			Good	Back lit inspection
54	F4	4F	FDA Sealed Edge**	x			1.6 (0.06)	Urethane	176°F (80°C)	Low	x	x		Good	Packaging, clean room and inspection
55	F5	5F	FDA Sealed Edge**	x			1.6 (0.06)	Urethane	176°F (80°C)	High	x	x		Good	Packaging, clean room and inspection
56		6F	Cut Resistant	x			2.1 (0.08)	Urethane	212°F (100°C)	Med.		x		Good	Oily product release, metal stamping
57		7F	Cut Resistant	x			2.5 (0.10)	Nitrile	176°F (80°C)	Med.		x		Poor	Felt-like, dry metal stamping, glass and ceramic
58		8F	Cut Resistant	x			1.6 (0.06)	Urethane	194°F (90°C)	Low		x		Good	Surface gold colored
59	F9	9F	Color Contrasting	x			1.6 (0.06)	PVC	158°F (70°C)	Med.		x		Poor	Black colored, hides overspray from ink jet
60	G0	0G	Color Contrasting	x	x		0.05 (1.3)	Urethane	212°F (100°C)	Low	x	x		Good	Green colored
61	G1	1G	Color Contrasting	x	x		0.05 (1.3)	Urethane	212°F (100°C)	Low	x			Good	Blue colored
63		3G	Electrically Conductive	x			0.05 (1.2)	Urethane	176°F (80°C)	Low		x	x	Good	Static conductive, electronics handling
64		4G	High Friction	x			4.4 (0.17)	PVC	176°F (80°C)	V-High		x		Poor	Dark Green colored, rough top surface, product cushioning, incline/decline apps
66		6G	Chemical Resistant	x			1.7 (0.07)	Polyester	212°F (100°C)	Med.	x	x		V-Good	Good cut resistance, metal stamping apps
67			Low Friction Cleated (Do not use with Z-Frame)	x			1.6 (0.06)	Polyester	212°F (100°C)	n/a	x			Good	Excellent product release, consult factory for part number and how to specify low friction
68	G8		FDA Encased**	x			1.5 (0.06)	Urethane	176°F (80°C)	Low	x	x		Good	Urethane enclosed for added sanitary protection
69	G9		FDA Encased**	x			2.2 (0.09)	Urethane	176°F (80°C)	Med.	x	x		Good	Urethane enclosed for added sanitary protection
71			FDA High Release	x			1.8 (0.07)	Urethane	212°F (100°C)	Low	x			Good	High release cover
72			Nose bar	x		x	1.2 (0.05)	Urethane	212°F (100°C)	Med.	x	x		Good	16 mm (5/8 in) Nose bar, medium friction
73			Nose bar Low friction		x	x	0.9 (0.03)	Urethane	212°F (100°C)	Low	x	x		Good	8 mm (5/16 in) Nose bar, low friction
75			Black Urethane	x			1.5 (0.06)	Urethane	176°F (80°C)	Low		x		Good	
76			Black Nose bar	x		x	1.2 (0.05)	Urethane	176°F (80°C)	Med.		x		Good	Black Color, 8 mm (5/16 in) nose bar
77			High Friction, green	x			2.2 (0.09)	Urethane	212°F (100°C)	High		x		Good	Green color, high friction, urethane, grooved
78			Chemical, Polyolefin, HF				1.4 (0.05)	Polyolefin	140°F (60°C)	High	x			V-Good	Chemical resistant, food grade
79			Chemical, Polyolefin, LF				1.3 (0.05)	Polyolefin	140°F (60°C)	Med.	x	x		V-Good	Chemical resistant, food grade
80			High Friction, silicone	x		x	1 (0.04)	Silicone	176°F (80°C)	High	x			Good	Silicone material, high friction
81			Low Friction, silicone	x		x	1 (0.04)	Silicone	212°F (100°C)	Med.	x			Good	Silicone material, low to medium friction

Dim = mm (in)

Note: Clipper Splices not available on Z-Frame Series Conveyors.

Note: Conveyors wider than 1,016 mm (40 in) require V-Guide belt tracking

Note: Belts with V-Guiding may have a slight high spot or rib on the top surface. This rib would run longitudinally along the center of the belt. Consult factory with applications for which this may cause interference.

\*\* Not available in 51 mm (2 in) widths

## Cleated Belt Profiles

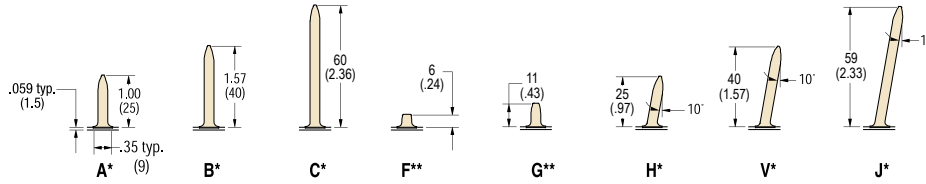

## Cleated Belt Selection Guide

Cleat Type	Base Belt	Belt Thickness	Surface Material	Color	Coefficient of Friction	V-Guidable	Maximum Part Temperature	FDA Approved	Chemical Resistance
A,B,C,F,G,H,V,J	Standard Base Belt	1.4 (.055)	Urethane	White	High	X	212°F (100°C)	Yes	Good
A,B,C,F,G,H,V,J	Low Friction Base Belt	1.5 (0.06)	Urethane	Natural	Low	X	212°F (100°C)	Yes	Good
A,B,C	Wide Cleated Base	1.5 (0.06)	Urethane	White	Medium	X	212°F (100°C)	Yes	Good

## Cleated Belt Spacing

- Minimum cleat spacing = 29 mm (1.13 in) - Cleat Selection could impact the minimum spacing. Contact the factory for details.

\*Maximum cleat spacing for 457 mm (18 in) and wider conveyors = 508 mm (20 in)

\*\*Maximum cleat spacing for 2 m (7 ft) and longer conveyors = 508 mm (20 in)  
18" and wider conveyors are limited to 2 m (7 ft) long

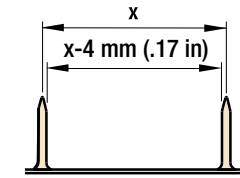

Tolerance  $\pm 2$  mm (.08 in)

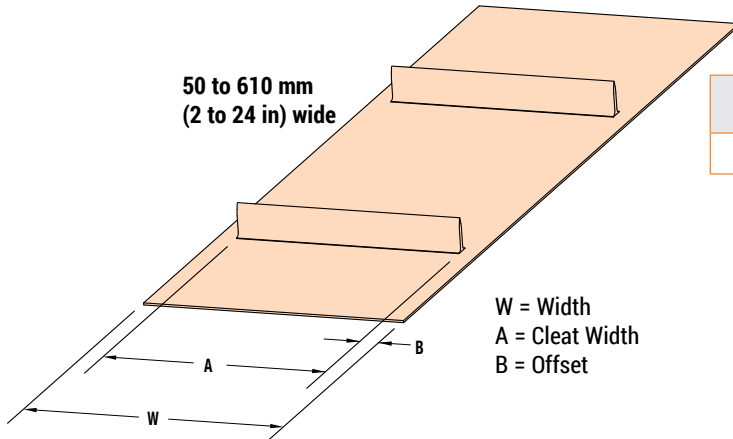

Cleat Type	Cleat Width (A)	Offset (B)
A,B,C,F, G,H,V,J	W- 30 mm (1.20 in)	15 mm (0.60 in)

W = Width  
A = Cleat Width  
B = Offset

Dim = mm (in)

Precision Move Belting

Precision Move Belt Selection Guide												
Part Number Reference	Belt Specifications	Tooth Pitch	Thickness	Material	Top Surface	Color	Maximum Part Temperature	Coefficient of Friction	Durometer	FDA Approved	Chemical Resistance	Max Width
1P	Low Friction	10 mm	4.5 (0.175)	Urethane with nylon top	Carcass	Green	195°F (91°C)	V-Low	N/A		Good	610 (24)
3P	High Friction	10 mm	4.5 (0.175)	Urethane	Smooth	White	195°F (91°C)	High	85A	x	Good	610 (24)
2T	High Strength	10 mm	4.6 (0.180)	Urethane with Kevlar cords	Smooth	Natural	160°F (71°C)	Med	88A		Good	152 (6)

Dim = mm (in)

Precision Move Cleat Profiles

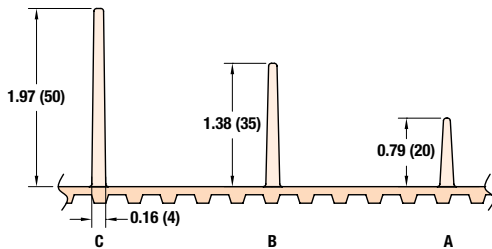

Specifications

- Base Belt Material: Belt 3P, 4.5 mm (0.175 in) thick, high friction FDA approved urethane, 195°F (91°C) maximum part temperature
- Cleat spacing in 10 mm increments
- Cleats are centered over tooth
- Minimum cleat spacing is approximately 50 mm (1.97 in) Consult Factory.

**NOTE:** 2200 Precision Move cleated belt widths 457 mm (18 in) and over will have a 20 mm (3/4 in) gap in the center cleats and use a return assembly that has a center support bearing.

Dim = mm (in)

## OPEN FRAME CONSTRUCTION

FOR WATER AND CHEMICAL DRAINAGE AND AIR COOLING

## ALL BELTS FULLY CONTAINED IN UHMW GUIDING

FOR MAINTENANCE FREE TRACKING

## UNIVERSAL T-SLOT

FOR EASE AND FLEXIBILITY OF ADDING ACCESSORIES USING A VARIETY OF INDUSTRY AVAILABLE HARDWARE

## eDRIVE®

LOW INERTIA ROTOR ALUMINUM BODY MOTORS PROVIDE LOWER TEMPERATURES IN SMALLER PACKAGE

## UNIVERSAL DRIVE

SINGLE PART NUMBER MOTOR/MOUNT/DRIVE PACKAGE COVERS ALL SPEED, LOAD AND MOUNTING POSITIONS FOR END DRIVE CONVEYORS





**CENTER DRIVE OPTION**  
FREES UP SPACE ON BOTH  
ENDS OF THE CONVEYOR

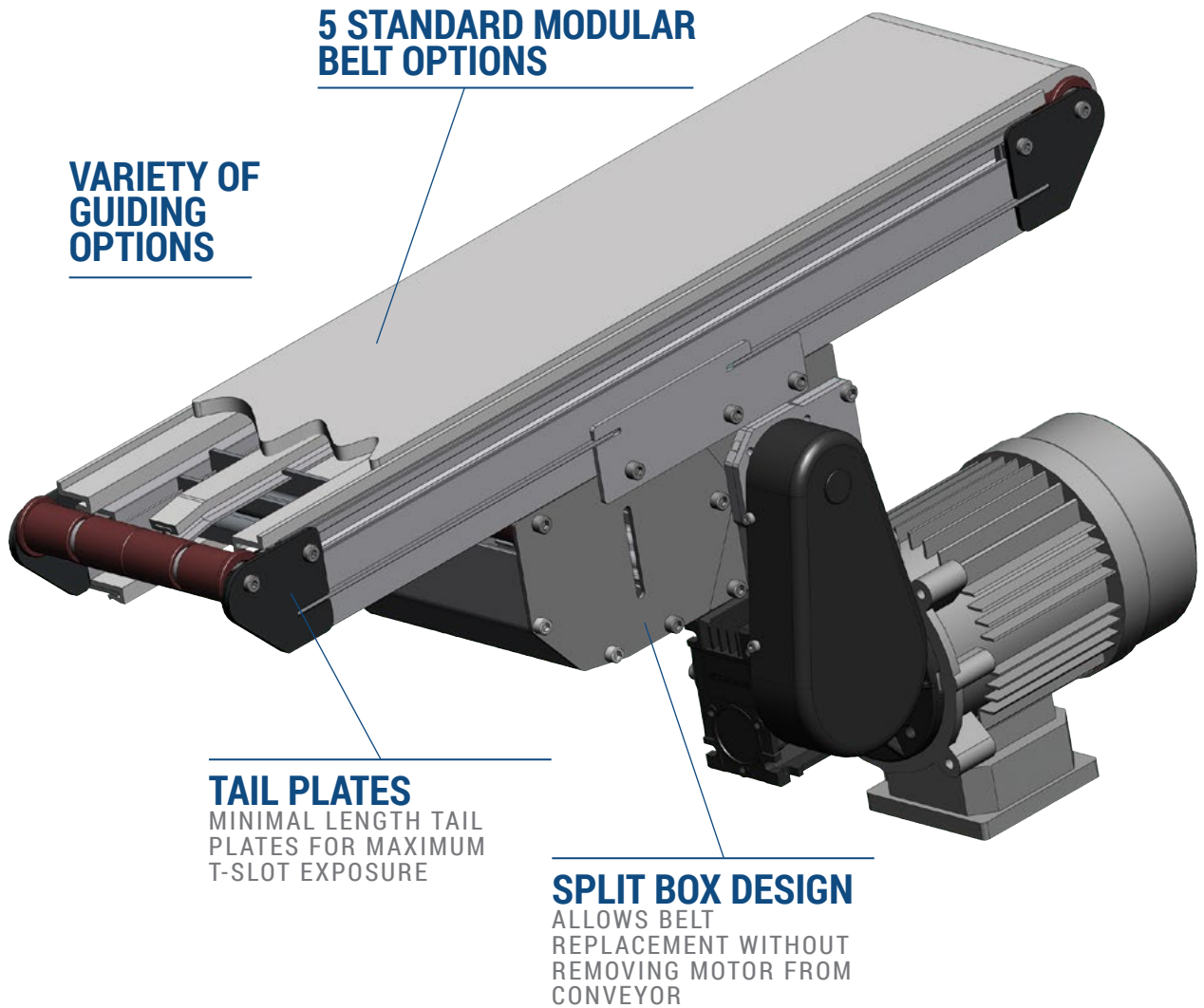

**5 STANDARD MODULAR  
BELT OPTIONS**

**VARIETY OF  
GUIDING  
OPTIONS**

**TAIL PLATES**  
MINIMAL LENGTH TAIL  
PLATES FOR MAXIMUM  
T-SLOT EXPOSURE

**SPLIT BOX DESIGN**  
ALLOWS BELT  
REPLACEMENT WITHOUT  
REMOVING MOTOR FROM  
CONVEYOR



**7.9 MM (0.31 IN) NOSEBAR TAIL OPTION**  
FOR SMALL PART TRANSFERS



Micropitch Belt

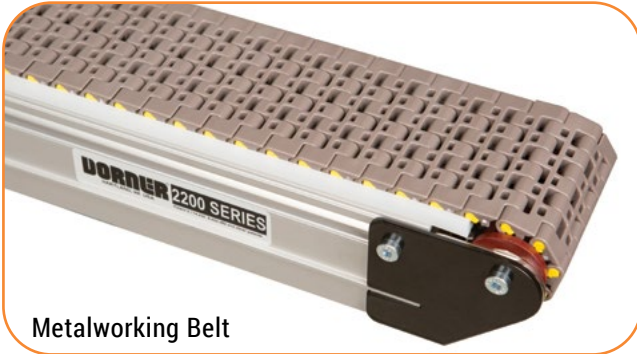

Metalworking Belt

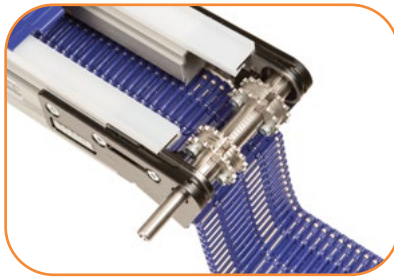

**STANDARD FEATURE:**  
**Open Frame Design**  
for water and chemical drainage  
and air cooling



**OPTIONAL: 7.9 mm (0.31 in)**  
**Nose Bar Transfer**  
Belt Speed up to 53.3 m/min (175 ft/  
min) (Micropitch Modular Belt only)

## Specifications

- Loads up to 68 kg (150 lbs)\*
- Belt speeds up to 76 m/min (250 ft/min)
- Belt widths: 76 to 610 mm (3 to 24 in)\*\*
- Conveyor lengths: 457 to 9,144 mm (18 in to 30 ft)
- Belt options:
  - Micropitch (General Purpose) Belts
    - 8 mm (0.33 in) micropitch modular belt
    - 43.2 mm (1.70 in) pitch diameter 17 tooth drive pulley turns approximately 136 mm (5.35 in) of belt per revolution
  - Metalworking Belts
    - 15 mm (0.60 in) pitch modular belt
    - 47.8 mm (1.88 in) pitch diameter 10 tooth drive pulley turns approximately 150 mm (5.91 in) of belt per revolution
- 12 mm diameter integral drive shaft
- Fully encapsulated in frame belt return

### 2200 Series Modular Belt End Drive Conveyor

22 MT E M W W - L L L L 1 1 A P P P P B B - X T<sup>1</sup> T<sup>2</sup> T<sup>3</sup> T<sup>4</sup>

- Conveyor Tail Options X (if required) \*See Drive Shaft Position Chart on next page
  - A = Drive Shaft (T<sup>1</sup> only)
  - D = Drive Shaft (T<sup>2</sup> only)
  - O = No Shaft
  - K = Keyed Auxiliary Shaft (T<sup>1</sup> and T<sup>2</sup> only)
  - S = Stub Shaft (T<sup>1</sup> and T<sup>2</sup> only)
- Belt Type
- Profile (D side)
- Profile (A side)
- Flow/Drive Shaft Position: A or D
- Infeed Tail Code: 0 = Standard idler, 1 = Nose Bar
- Mounting Bracket Options: 1 = Conveyor to include mounting brackets, 3 = Conveyor not to include mounting brackets
- Conveyor Length Reference: L.L.L.L in feet
- Conveyor Width Reference
- Documentation Language: M = US, U = Europe

\* Conveyor load capacity depends on conveyor size, incline, motor position, accumulated loads and other factors.

\*\* Belt selection limits width options

Order gearmotor mounting packages and gearmotors separately, see pages 73-78  
For support stands and accessories, see pages 90-95

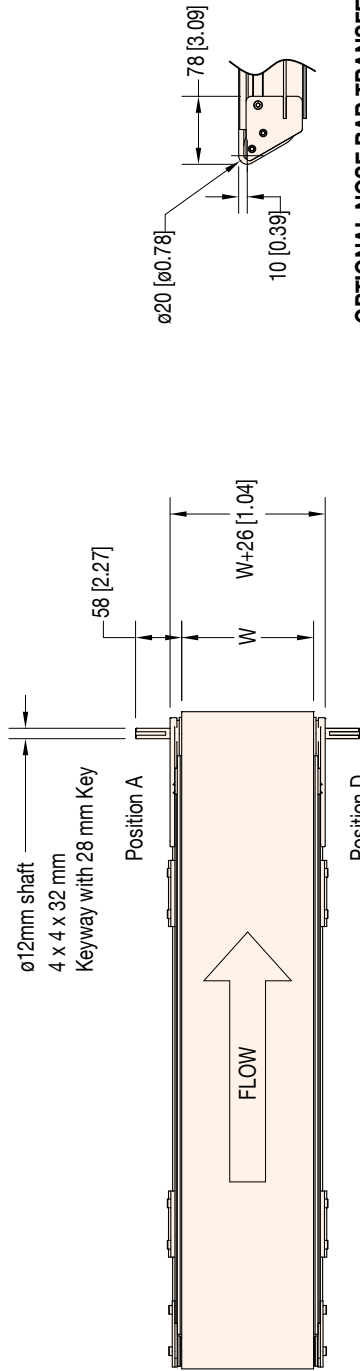

### OPTIONAL NOSE BAR TRANSFER

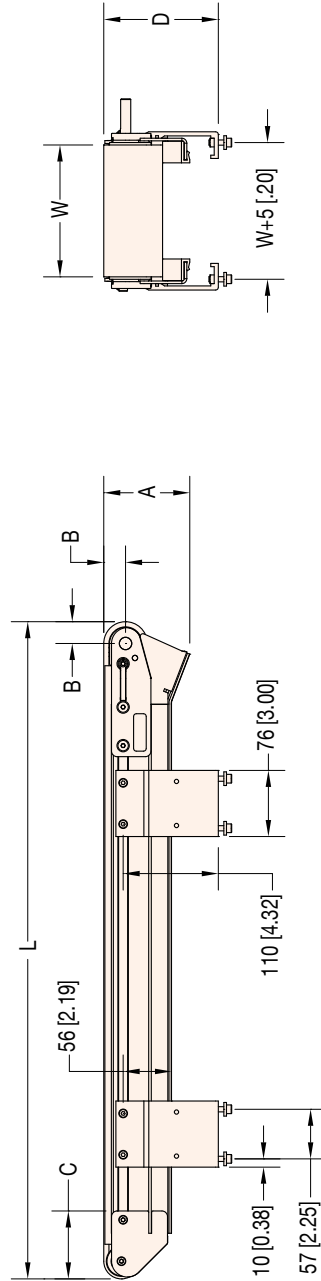

- A=99 [3.90] FOR MICROPITCH BELT
- 102 [4.00] FOR METALWORKING BELT
- B=25 [.99] FOR MICROPITCH BELT
- 28 [1.09] FOR METALWORKING BELT
- C=78 [3.08] FOR MICROPITCH BELT
- 81 [3.18] FOR METALWORKING BELT
- D=132 [5.20] FOR MICROPITCH BELT
- 135 [5.32] FOR METALWORKING BELT

W = Conveyor Belt Width Dim = mm (in)

Standard Micropitch Sizes		Standard Metalworking Sizes				
Conveyor Width Reference	04	06	08	12	18	24
Conveyor Belt Width (W)	102 mm (4 in)	152 mm (6 in)	203 mm (8 in)	305 mm (12 in)	457 mm (18 in)	610 mm (24 in)
Conveyor Length Reference	0150	0001 increments up to...				
Conveyor Length (L)	457 mm (1.5 ft)	3 mm (0.1 in) increments up to...				
Conveyor Width Reference	03	06	09	12	18	24
Conveyor Belt Width (W)	76 mm (3 in)	152 mm (6 in)	229 mm (9 in)	305 mm (12 in)	457 mm (18 in)	610 mm (24 in)
Conveyor Length Reference	0150	0001 increments up to...				
Conveyor Length (L)	457 mm (1.5 ft)	3 mm (0.1 in) increments up to...				

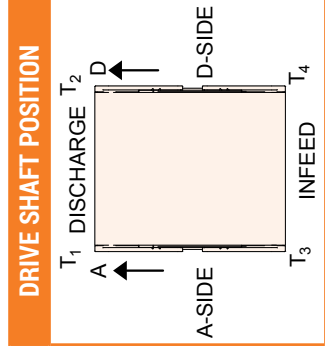

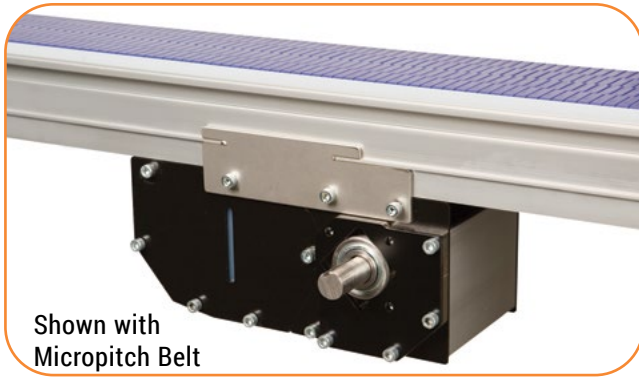

## Specifications

- Loads up to 68 kg (150 lbs)\*
- Belt speeds up to 76 m/min (250 ft/min)
- Belt widths: 76 to 610 mm (3 to 24 in)\*\*
- Conveyor lengths: 813 to 9,144 mm (32 in to 30 ft)
- Belt options:
  - Micropitch (General Purpose) Belts
    - 8 mm (0.33 in) micropitch modular belt
    - 43.2 mm (1.70 in) pitch diameter 17 tooth drive pulley turns approximately 136 mm (5.35 in) of belt per revolution
  - Metalworking Belts
    - 15 mm (0.60 in) pitch modular belt
    - 47.8 mm (1.88 in) pitch diameter 10 tooth drive pulley turns approximately 150 mm (5.91 in) of belt per revolution
- 20 mm (3/4 in) diameter integral drive shaft
- Fully encapsulated in frame belt return



**STANDARD FEATURE:**  
**Open Frame Design**  
for water and chemical drainage  
and air cooling



**OPTIONAL: 7.9 mm (0.31 in)**  
**Nose Bar Transfer**  
Belt Speed up to 153.3 m/min (75 ft/min)  
(Micropitch Modular Belt only)

### 2200 Series Modular Belt Center Drive Conveyor

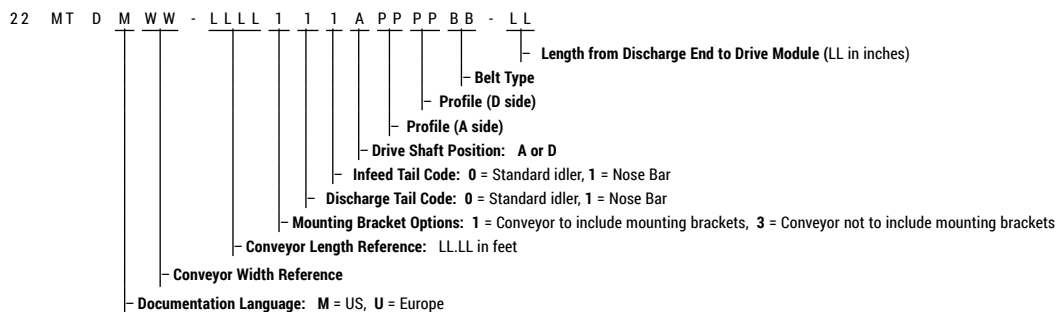

\* Conveyor load capacity depends on conveyor size, incline, motor position, accumulated loads and other factors.

\*\* Belt selection limits width options

Order gearmotor mounting packages and gearmotors separately, see pages 73-78  
For support stands and accessories, see pages 90-95

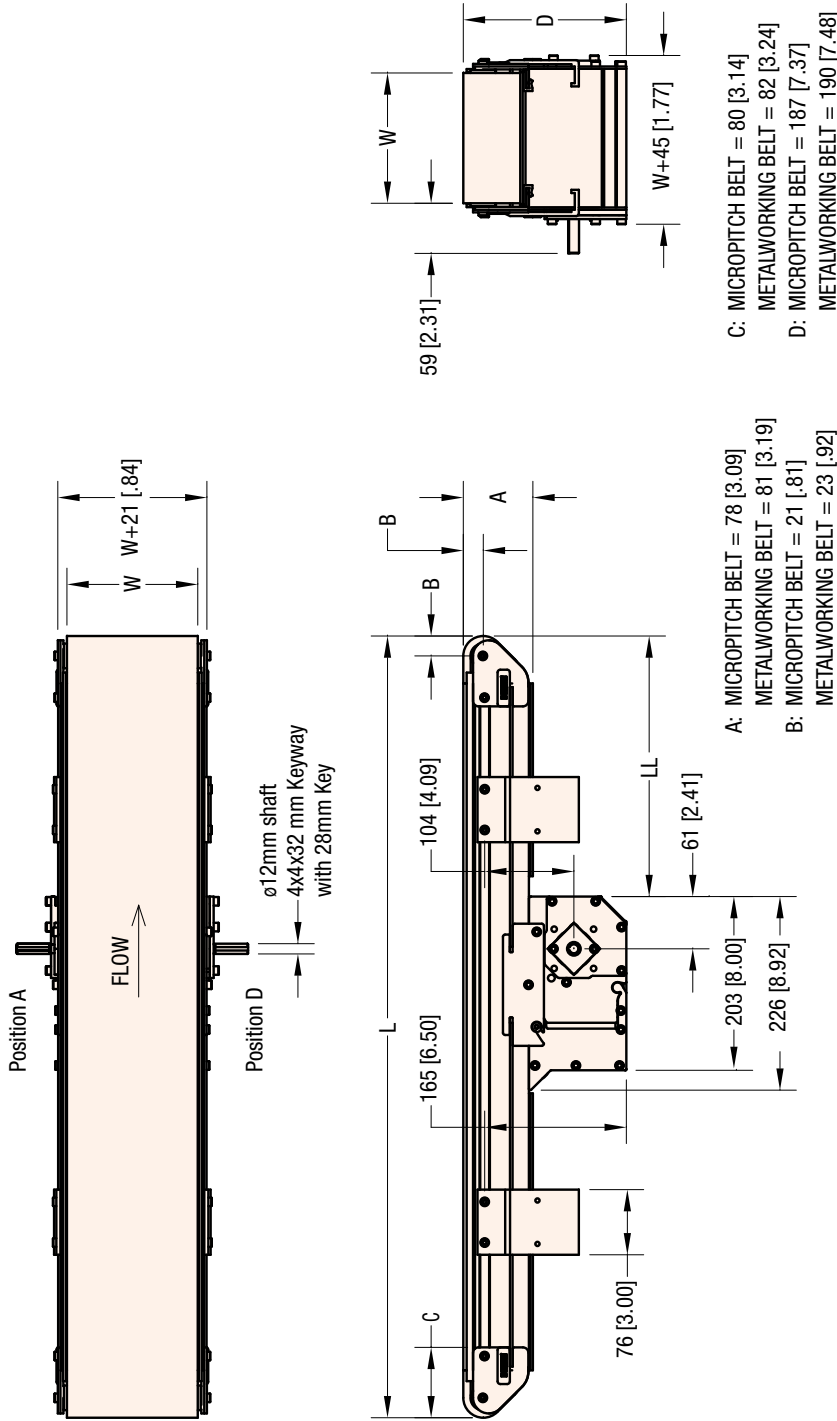

LL (Min = 10, MAX = 60) W = Conveyor Belt Width Dim = mm (in)

Standard Micropitch Sizes						
Conveyor Width Reference	04	06	08	12	18	24
Conveyor Belt Width (W)	102 mm (4 in)	152 mm (6 in)	203 mm (8 in)	305 mm (12 in)	457 mm (18 in)	610 mm (24 in)
Conveyor Length Reference	0150	0001 increments up to...				
Conveyor Length (L)	813 mm (2.67 ft)	3 mm (0.1 in) increments up to...				
Standard Metalworking Sizes						
Conveyor Width Reference	03	06	09	12	18	24
Conveyor Belt Width (W)	76 mm (3 in)	152 mm (6 in)	229 mm (9 in)	305 mm (12 in)	457 mm (18 in)	610 mm (24 in)
Conveyor Length Reference	0150	0001 increments up to...				
Conveyor Length (L)	813 mm (2.67 ft)	3 mm (0.1 in) increments up to...				

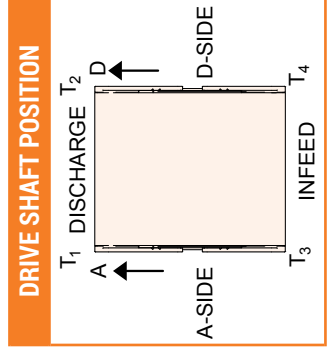



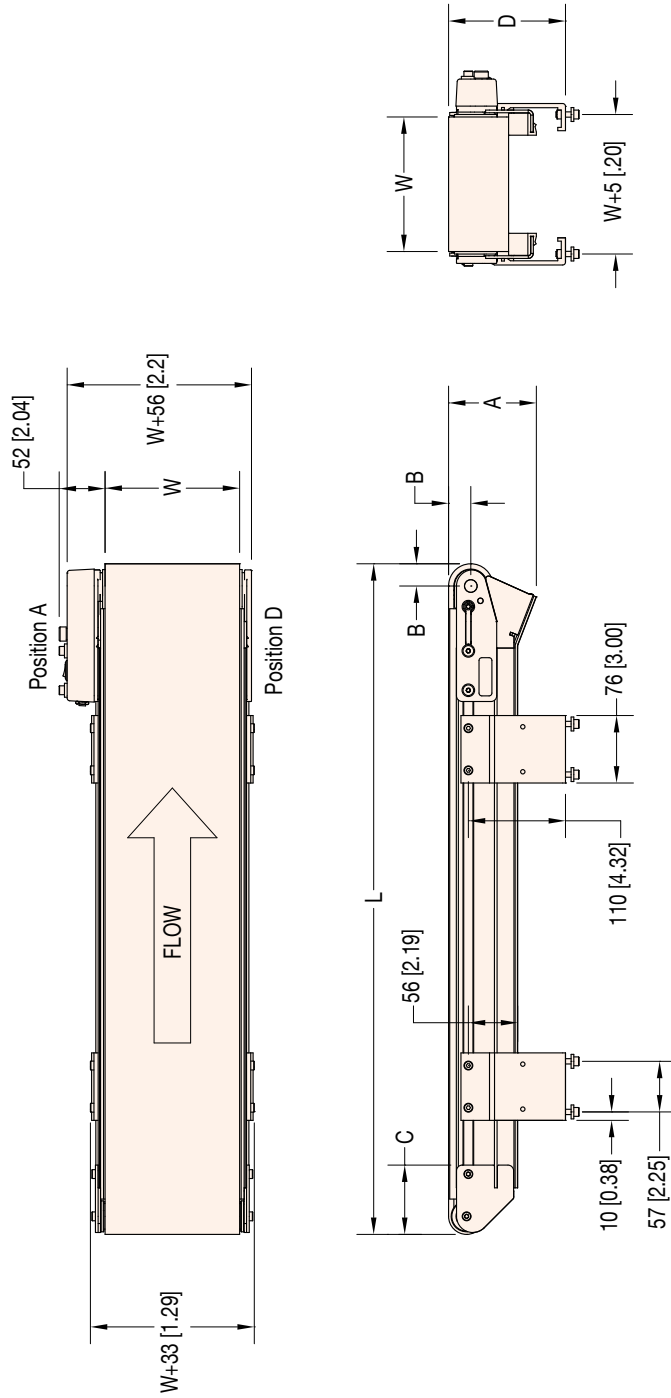

- A=99 [3.90] FOR MICROPITCH BELT
- 102 [4.00] FOR METALWORKING BELT
- B=25 [.99] FOR MICROPITCH BELT
- 28 [1.09] FOR METALWORKING BELT
- C=78 [3.08] FOR MICROPITCH BELT
- 81 [3.18] FOR METALWORKING BELT
- D=132 [5.20] FOR MICROPITCH BELT
- 135 [5.32] FOR METALWORKING BELT

W = Conveyor Belt Width Dim = mm (in)

Standard Micropitch Sizes						
Conveyor Width Reference	04	06	08	12	18	24
Conveyor Belt Width (W)	102 mm (4 in)	152 mm (6 in)	203 mm (8 in)	305 mm (12 in)	457 mm (18 in)	610 mm (24 in)
Conveyor Length Reference	0150	0001 increments up to...		3000		
Conveyor Length (L)	457 mm (1.5 ft)	3 mm (0.1 in) increments up to...		9144 mm (30 ft)		
Standard Metalworking Sizes						
Conveyor Width Reference	03	06	09	12	18	24
Conveyor Belt Width (W)	76 mm (3 in)	152 mm (6 in)	229 mm (9 in)	305 mm (12 in)	457 mm (18 in)	610 mm (24 in)
Conveyor Length Reference	0150	0001 increments up to...		1000		
Conveyor Length (L)	457 mm (1.5 ft)	3 mm (0.1 in) increments up to...		3048 mm (10 ft)		

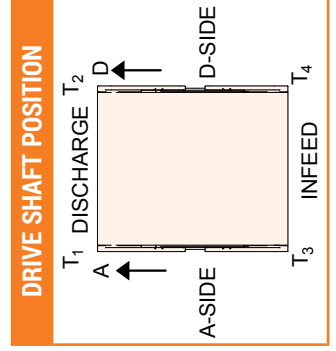

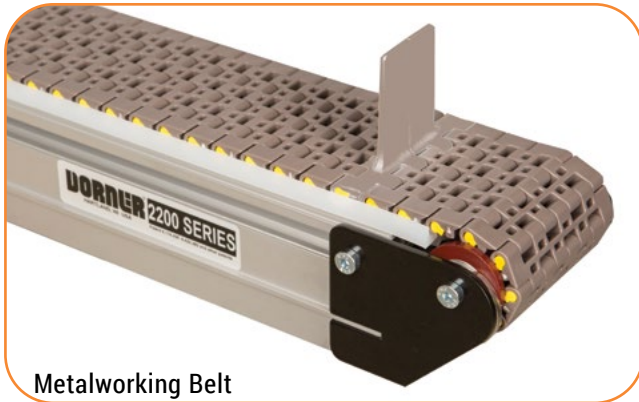

## Specifications

- Loads up to 68 kg (150 lbs)\*
- Belt speeds up to 76 m/min (250 ft/min)
- Belt widths: 76 to 610 mm (3 to 24 in)\*\*
- Conveyor lengths: 457 to 9,144 mm (18 in to 30 ft)
- Belt options:
  - Metalworking Belt
    - 47.8 mm (1.88 in) pitch diameter 10 tooth drive pulley turns approximately 150 mm (5.91 in) of belt per revolution
- 12 mm diameter integral drive shaft
- Fully encapsulate in frame belt return

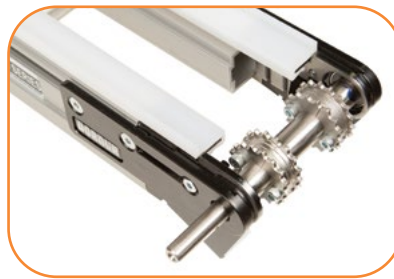

## STANDARD FEATURE: OPEN FRAME DESIGN

for water and chemical drainage  
and air cooling

### 2200 Series Modular Cleated Belt Conveyor

22	MT	C	M	WW	-	LLLL	1	A	P	A	B	B	S	S	S	S	-	X	T <sup>1</sup>	T <sup>2</sup>	T <sup>3</sup>	T <sup>4</sup>
																		- Conveyor Tail Options X (if required) *See Drive Shaft Position Chart on next page				
																		A = Drive Shaft (T <sup>1</sup> only)		C = Drive Shaft (T <sup>2</sup> only)		
																		O = No Shaft		K = Keyed Auxiliary Shaft		
																		S = Stub Shaft		M = Mag Location (T <sup>3</sup> or T <sup>4</sup> only)		
																		- Cleat Spacing: SS.SS in inches				
																		- Belt Type				
																		- Cleat Height				
																		- Profile: 0 = Low Side, 2 = 25 mm (1 in) Cleated, 3 = 50 mm (2 in) Cleated				
																		- Flow/Drive Shaft Position: A or D				
																		- Mounting Bracket Options: 1 = Conveyor to include mounting brackets, 3 = Conveyor not to include mounting brackets				
																		- Conveyor Length Reference: L.L.L.L in feet				
																		- Conveyor Width Reference				
																		- Documentation Language: M = US, U = Europe				

\* Conveyor load capacity depends on conveyor size, incline, motor position, accumulated loads and other factors.

\*\* Belt selection limits width options

Order gearmotor mounting packages and gearmotors separately, see pages 73-78  
For support stands and accessories, see pages 90-95

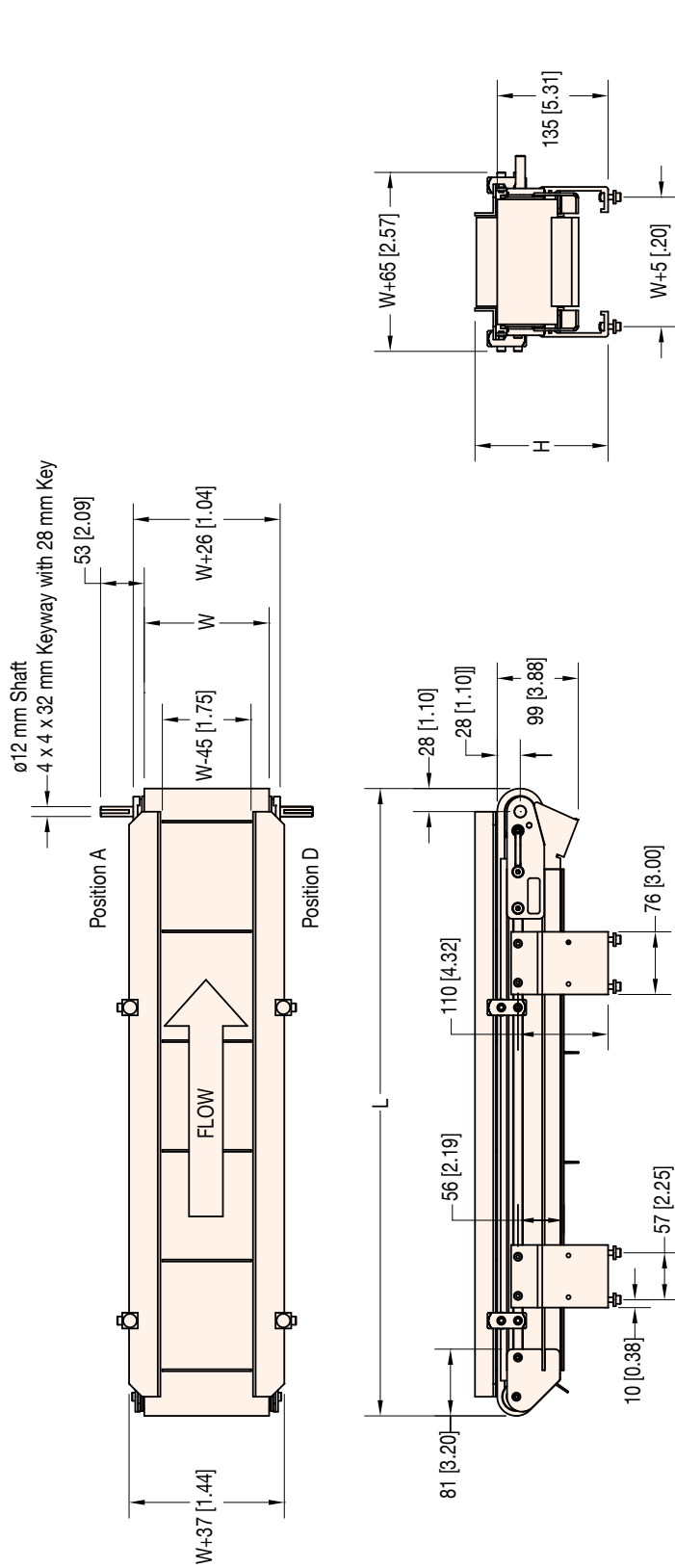

H=162 [6.38] FOR 25 mm [1 in] TALL CLEATED PROFILE  
 H=188 [7.38] FOR 50 mm [2 in] TALL CLEATED PROFILE

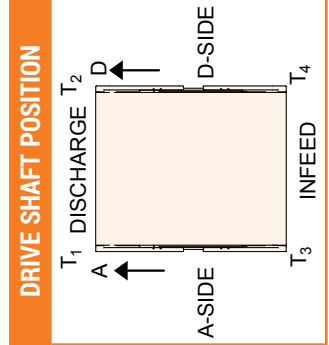

W = Conveyor Belt Width Dim = mm (in)

Standard Metalworking Sizes						
Conveyor Width Reference	03	06	09	12	18	24
Conveyor Belt Width (W)	76 mm (3 in)	152 mm (6 in)	229 mm (9 in)	305 mm (12 in)	457 mm (18 in)	610 mm (24 in)
Conveyor Length Reference	0150		0001 increments up to...		3000	
Conveyor Length (L)	457 mm (1.5 ft)		3 mm (0.1 in) increments up to...		9144 mm (30 ft)	

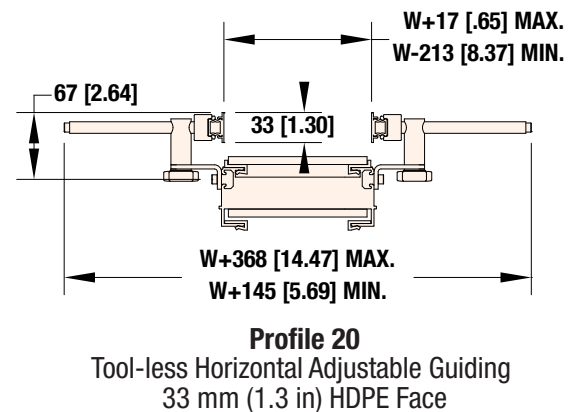
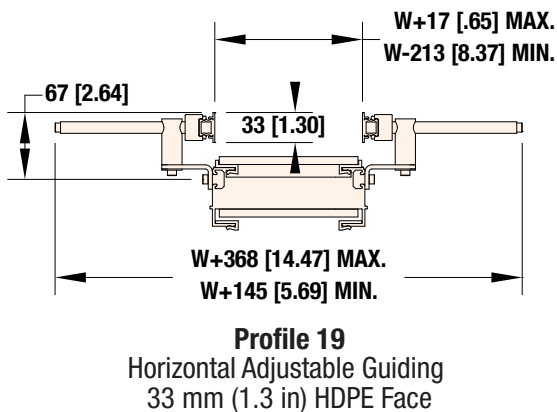
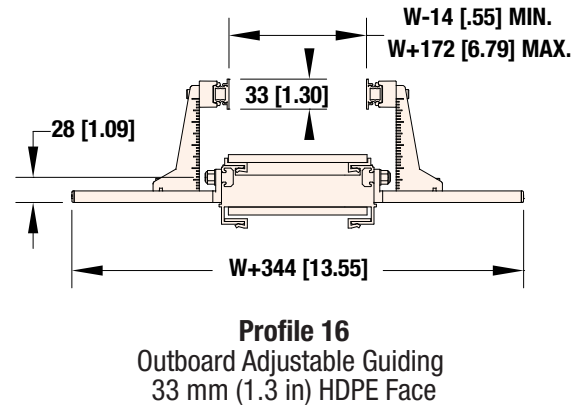
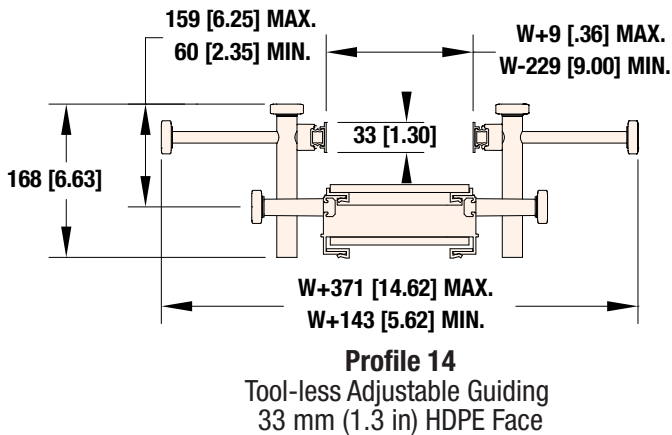
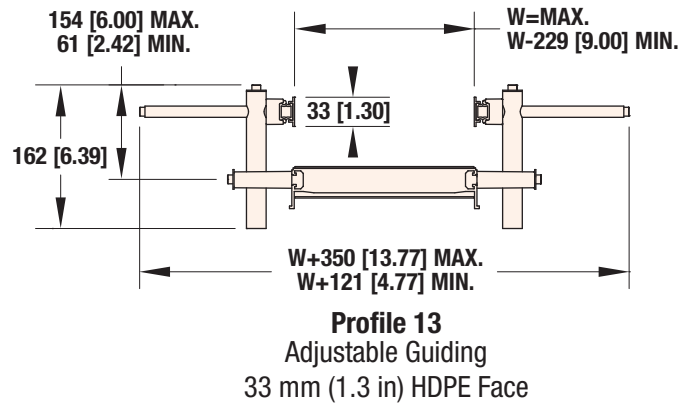
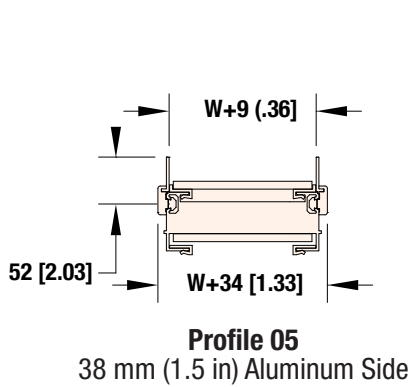
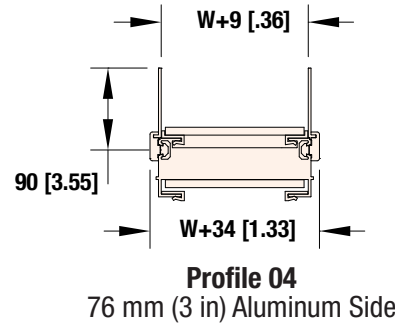
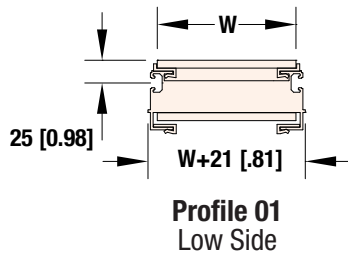

W = Conveyor Belt Width Dim = mm (in)

Due to the wide variety of drive set ups and applications, point of installation guarding is the responsibility of the end user.

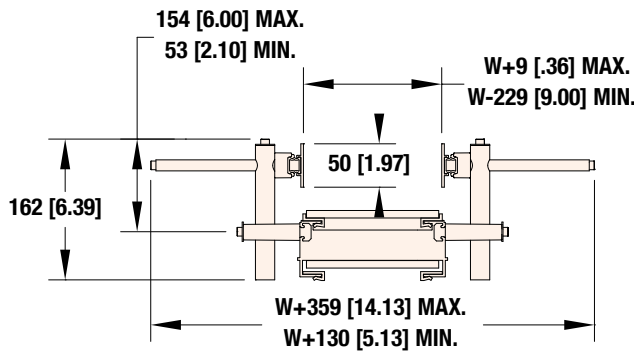

**Profile 33**  
Adjustable Guiding  
50 mm (2 in) HDPE Face

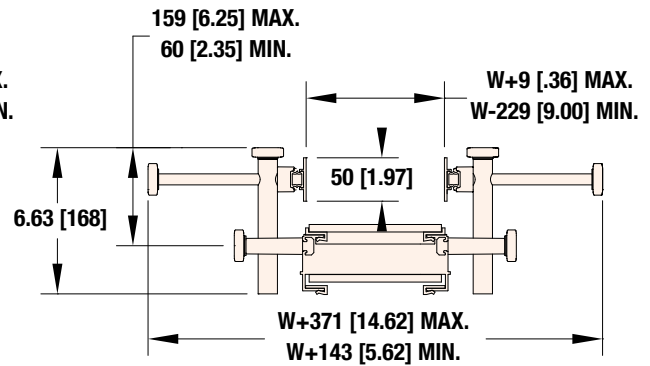

**Profile 34**  
Tool-less Adjustable Guiding  
50 mm (2 in) HDPE Face

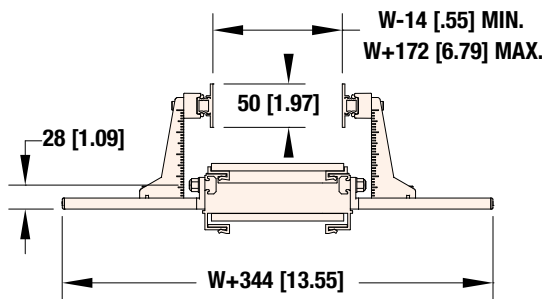

**Profile 36**  
Outboard Adjustable Guiding  
50 mm (2 in) HDPE Face

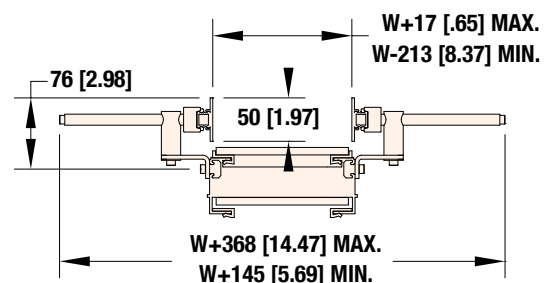

**Profile 39**  
Horizontal Adjustable Guiding  
50 mm (2 in) HDPE Face

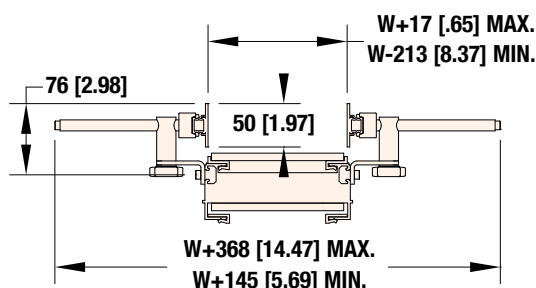

**Profile 40**  
Tool-less Horizontal Adjustable Guiding  
50 mm (2 in) HDPE Face

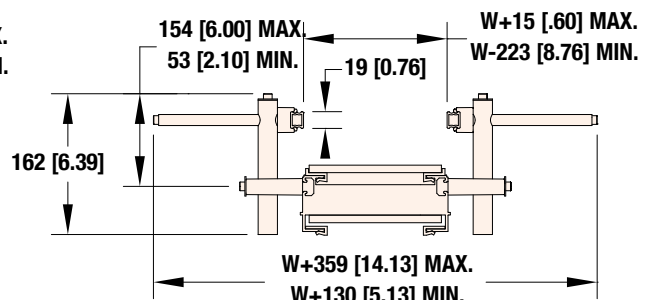

**Profile 43**  
Adjustable Guiding  
Aluminum Face

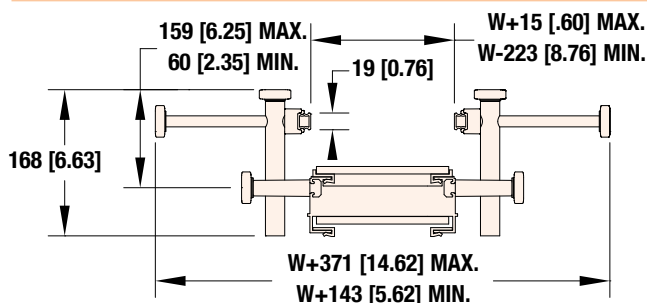

**Profile 44**  
Tool-less Adjustable Guiding  
Aluminum Face

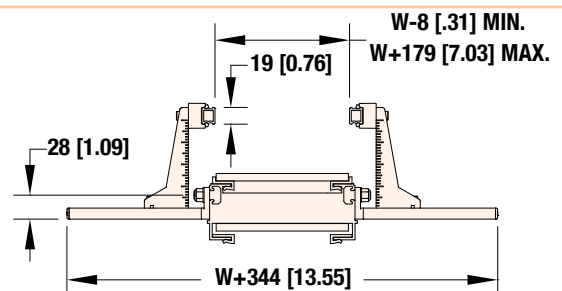

**Profile 46**  
Outboard Adjustable Guiding  
Aluminum Face

W = Conveyor Belt Width Dim = mm (in)

Due to the wide variety of drive set ups and applications, point of installation guarding is the responsibility of the end user.

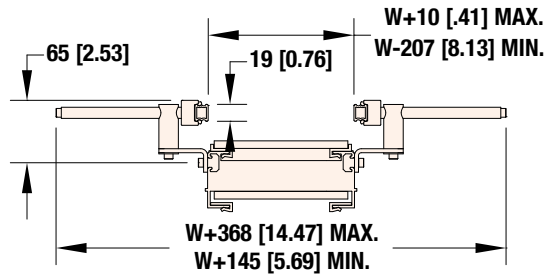

**Profile 49**  
Horizontal Adjustable Guiding  
Aluminum Face

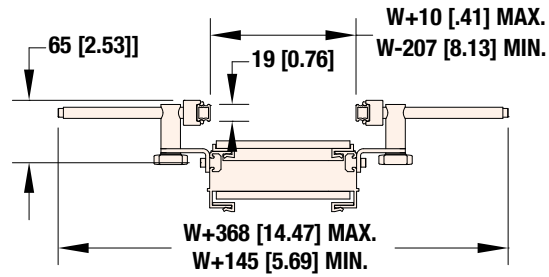

**Profile 50**  
Tool-less Horizontal Adjustable Guiding  
Aluminum Face

## Standard Modular Belt Selection Guide

Belt Type	Description	Percent Open	Tooth Pitch	Thickness	Material	Color	Maximum Part Temperature	Coefficient of Friction	FDA Approved	Nose Bar	Cleated	Chemical Resistance
01	Micropitch, Closed Mesh	N/A	8.1 (0.32)	6 (0.236)	Acetal	Blue	200 deg F (93 deg C)	0.25	X	X		Good
30	Metalworking Accumulation, Open Mesh	26%	15 (0.59)	8.7 (0.34)	Acetal	Brown	180 deg F (82 deg C)	0.22	X		X	Good
31	Metalworking Chemical Resistant, Open Mesh	26%	15 (0.59)	8.7 (0.34)	Polypropylene	White	220 deg F (104 deg C)	0.33	X		X	Excellent
40	Metalworking Accumulation, Closed Mesh	N/A	15 (0.59)	8.7 (0.34)	Acetal	Brown	180 deg F (82 deg C)	0.22	X		X	Good
41	Metalworking Chemical Resistant, Closed Mesh	N/A	15 (0.59)	8.7 (0.34)	Polypropylene	White	220 deg F (104 deg C)	0.33	X		X	Excellent

Note: White belt is available, contact factory for details.

## Specialty Modular Belt Selection Guide

Belt Type	Description	Percent Open	Tooth Pitch	Thickness	Material	Color	Maximum Part Temperature	Coefficient of Friction	FDA Approved	Nose Bar	Cleated	Chemical Resistance
02	Micropitch, Open Mesh	34%	8.1 (0.32)	6 (0.236)	Acetal	Blue	200 deg F (93 deg C)	0.3	X	X		Good
32	Metalworking Heat Resistant, Open Mesh*	26%	15 (0.59)	8.7 (0.34)	Nylon	Black	375 deg F (190 deg C)	0.3				Good
42	Metalworking Heat Resistant, Closed Mesh*	N/A	15 (0.59)	8.7 (0.34)	Nylon	Black	375 deg F (190 deg C)	0.3				Good

Note: White belt is available, contact factory for details.

\* Although the belt material can handle temperatures up to 375°F, the core temperature of belt must not exceed 220°F. Please consult the factory for details. Also note: the conveyor wearstrip material located under the belt is designed for temperatures up to 175°F. For applications exceeding these temperatures contact the factory.

## Cleated Belt Profiles

- Metalworking belt conveyors only. See page 42 & 43 for more details.

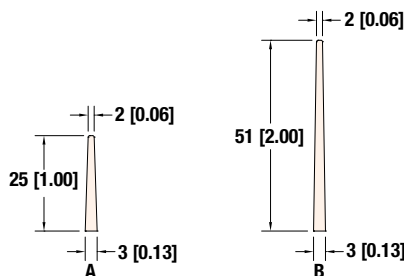

Dim = mm (in)

## Gearmotors Mounting Package & Gearmotor Selection Steps

- Step 1:** Select a **Gearmotor Mounting Package**. For End Drive conveyors, select a side, bottom, top, flush or bolster drive mount (pages 48-55). If a Center Drive or Mid Drive conveyor is being outfitted, refer to the Center Drive section on pages 56-57. Be sure to note if it is for a **90°** or **Parallel Shaft Gearmotor**.
- Step 2:** Using **Belt Speed and Load Requirements**, determine the required **Gearmotor Type** (Light, Heavy or Standard) for your application using the chart below.
- Step 3:** Find the appropriate set of Belt Speed Charts (pages 51, 52, 54, 55, 57 and 58) for the Mounting Package you selected and choose between the **Fixed** or **Variable Speed** chart.
- Step 4:** Go down the first column of the Belt Speed Chart and locate the required **Belt Speed** for your application. If the desired belt speed is not listed, round up to the next higher speed. (Dorner offers much more than just the belt speeds listed in the tables, contact the factory for complete details)
- Step 5:** From the row containing your required **Belt Speed**, check to be sure that speed is available for the **Mount Package** you chose. (End Drive Only - Top, Bottom or Side)
- Step 6:** Use the Drive / Driven Pulley Kit combination to complete your Mounting Package Part Number
- Step 7:** Note the **RPM from Gearmotor**, it will be needed to select the correct Gearmotor from the Gearmotor Chart.
- Step 8:** Reference the **Gearmotor Chart #** to locate a compatible Gearmotor Chart on pages 59-64. Be sure to select a Gearmotor Chart to match your **Gearmotor Type** (Light, Standard or Heavy) and your **Mounting Package** while meeting your electrical requirements.  
(Red = Parallel Shaft or Blue = 90°)
- Step 9:** Using the **RPM from Gearmotor** (Step 6), locate the **Part Number** for your Gearmotor from the Gearmotor Table.

	GEARMOTOR TYPE		Conveyor Load - Kg )Lbs)											
	Light Load	Standard Load	(4.5 (10)	9.1 (20)	13.6 (30)	18.2 (40)	22.7 (50)	27.3 (60)	31.8 (70)	36.4 (80)	40.9 (90)	45.5 (100)	50 (110)	54.5 (120)
	Standard Load	Heavy Load												
	Heavy Load													
Belt Speed - m/min (Ft/min)	0-4.6 (0-15)													
	4.9-9.1 (16-30)													
	9.5-13.7 (31-45)													
	14-18.3 (46-60)													
	18.6-22.9 (61-75)													
	23.2-27.4 (76-90)													
	27.7-33.5 (91-110)													
	33.8-39.6 (111-130)													
	39.9-45.7 (131-150)													
	46-53.4 (151-175)													
	53.7-61 (176-200)													
	61.3-68.6 (201-225)													
	68.9-76.2 (226-250)													
	76.5-83.8 (251-275)													

Gearmotor Mounting Package Selection Guide		APPLICATION										
		Wet Products / Environments	76 (3 in) and taller products	Manual / Automated Assembly	Table top mounting	Tight machine interface	Aesthetics	Driving multiple conveyors	Clearance at discharge	Operator Ergonomics	Test and Inspect	Metal Forming
MOUNT PACKAGE	Side Mount Package	X	X		X				X			
	Top Mount Package	X			X				X			
	Bottom Mount Package		X	X			X		X	X		
	Center Drive Conveyor					X			X	X		
	Flush Mount								X	X		
	Bolster Mount Package							X				X
	Common Drive Package							X				



## Specifications

- Complete package including motor, mount package, and controller
- Compatible with all 2200 Series End Drive Conveyors including Belted, Modular Belt, and Precision Move
- 21 unique mounting positions including 12 outboard positions and 9 inboard positions
- Belt speed = Variable 1.5 to 70.1 m/min (5-230 ft/min)
- Load Capacity:
  - Up to 36.3 kg (80 lbs) for belt speeds to 45.7 m/min (150 ft/min)
  - Up to 18.1 kg (40 lbs) for belt speeds to 70.1 m/min (230 ft/min)

## Motor:

- Transverse Flux Motor technology
  - Small form factor motor eliminates gearbox
  - High torque at low speeds
- Provides constant output torque from 10 to 300 rpm
- 300 Watt
- Totally Enclosed Non-ventilated
- IP 54
- 89% efficient
- CE Certified
- UL Listed
- RoHS Compliant

## Variable Speed Controller:

- Nema 1 / IP 20 Enclosure
- Input Voltage
  - 115V, 1 Phase, 60 Hz
  - 200-240V, 1 or 3 Phase, 47 to 63 Hz
- Includes membrane keypad for start/stop and speed control
- Multi-setting parameter menu
- Discrete I/O control capable
- Includes digital readout for speed and parameter setting
- 115 V , 1 Phase unit includes power cord
- 200-240 V units, input power wiring by others
- CE Certified (EMI Filter by others)
- UL Listed
- RoHS Compliant



## STANDARD FEATURE:

Mounts in Multiple Positions

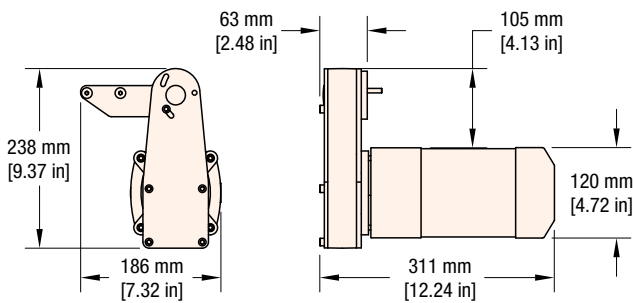

Standard Load Parallel Shaft Gearmotor

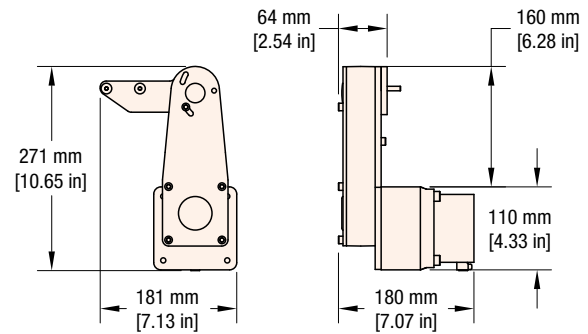

Brushless DC Parallel Shaft Gearmotor

Part Number	Input voltage	Input phase	Input Hz	Peak Input Amps	Motor Power	Motor Face	Reversing	Motor RPM*	In-Lbs	N-m
22UM1	115	1	47-63	10	0.5 Hp (3.7 Kw)	NEMA 100	Yes	10 - 300/500	49/44	5.5/4.9
22UM2	208/230	1 or 3	47-63	5	0.5 Hp (3.7 Kw)	NEMA 100	Yes	10 - 300/500	49/44	5.5/4.9

Dim = mm (in)

## Side Mount Package, 90° Gearmotor

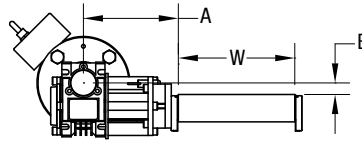
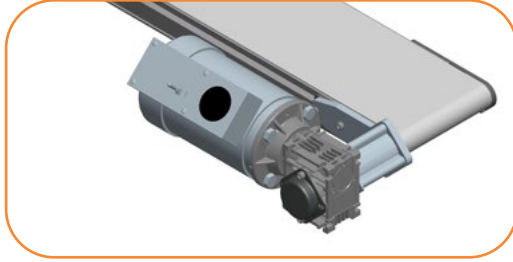

A:	2200 = 123 [4.85]	2700 = 145 [5.71]
B:	2200 = 15 [0.59]	2700 = 6 [0.23]
C:	2200 = 27 [1.05]	2700 = 12 [0.48]

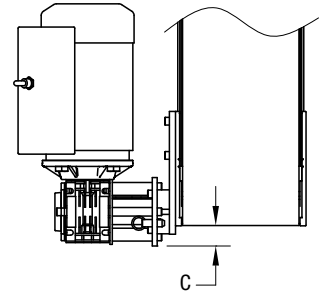

- Includes gearmotor mounting bracket, coupling, coupling guard and mounting hardware

## Bottom Mount Package, 90° Gearmotor (2200 only\*)

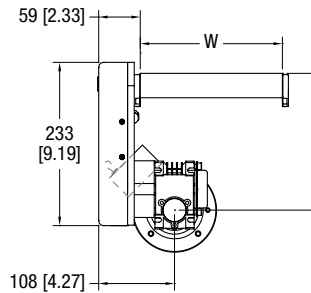
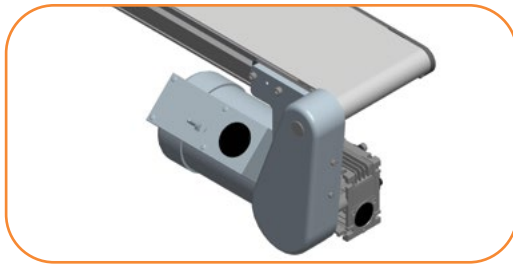

A: Standard Load Flat Belt = 138 (5.43)  
Standard Load Cleated Belt = 198 (7.89)

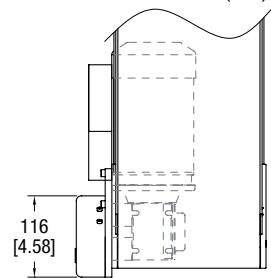

- Includes gearmotor mounting bracket, timing belt and pulleys, guard cover and mounting hardware

\*for 2700 see flush bottom mount

## Top Mount Package, 90° Gearmotor

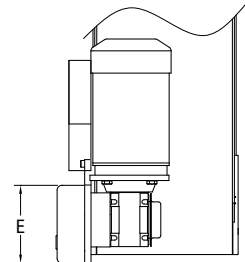
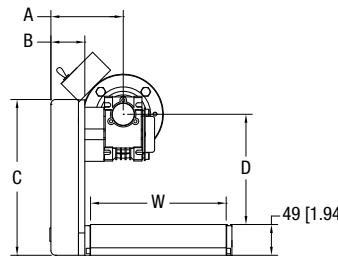
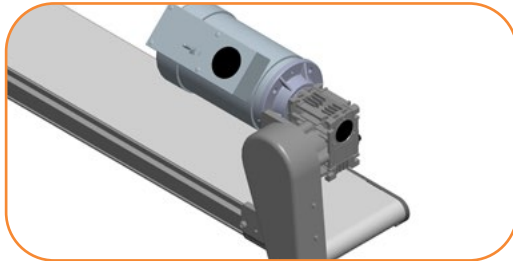

- Includes gearmotor mounting bracket, timing belt and pulleys, guard cover and mounting hardware

A:	2200 = 108 [4.27]	2700 = 105 [4.12]
B:	2200 = 51 [2.00]	2700 = 49 [1.94]
C:	2200 = 233 [9.19]	2700 = 235 [9.25]
D:	2200 = 162 [6.40]	2700 = 160 [6.31]
E:	2200 = 116 [4.58]	2700 = 103 [4.06]

## 90° Gearmotor Location Options

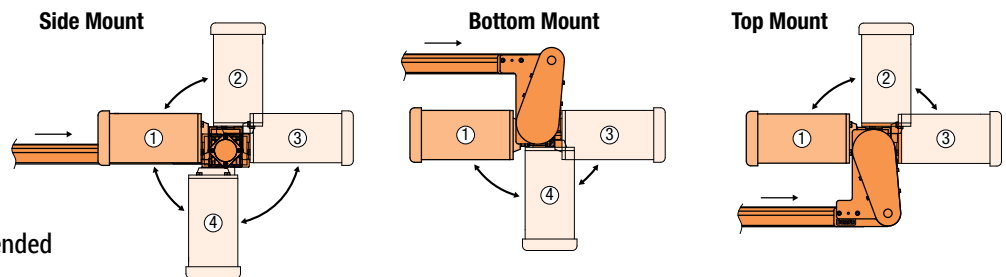

**Note:** Position 1 recommended

Consult factory for details

Note: Conveyor and gearmotor are not included in the mounting package and must be ordered separately. **W** = Conveyor Belt Width **Dim** = mm (in)

For ordering information, see page 66

# 2200/2700 SERIES

# END DRIVE MOUNTING PACKAGES

## Side Mount Package, Parallel Shaft Gearmotor (2200 only)

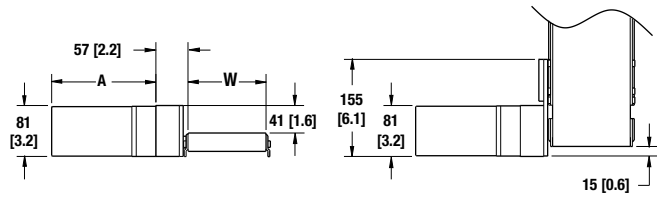

A: Light Load, Fixed Speed and VFD Variable Speed	= 117 (4.6)
Light Load, DC Variable	= 170 (6.7)
Light Load CE Fixed Speed	= 183 (7.2)

### Light load gearmotors only

- Includes gearmotor mounting bracket, coupling, coupling guard and mounting hardware

## Bottom Mount Package, Parallel Shaft Gearmotor (2200 only\*)

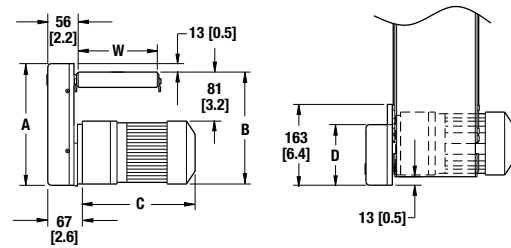

A: Light Load Flat Belt	= 175 (6.9)	C: Light Load, Fixed Speed and VFD Variable Speed	= 117 (4.6)
Light Load Cleated Belt	= 226 (8.9)	Light Load, DC Variable Speed	= 170 (6.7)
Standard Load Flat Belt	= 234 (9.2)	Standard Load	= 267 (10.5)
Standard Load Cleated Belt	= 234 (9.2)	D: Light Load Flat Belt	= 155 (6.1)
B: Light Load Flat Belt	= 158 (6.2)	Light Load Cleated Belt	= 142 (5.6)
Light Load Cleated Belt	= 211 (8.3)	Standard Load Flat Belt	= 116 (4.6)
Standard Load Flat Belt	= 216 (8.5)	Standard Load Cleated Belt	= 116 (4.6)
Standard Load Cleated Belt	= 262 (10.3)		

- Includes gearmotor mounting bracket, timing belt and pulleys, guard cover and mounting

\*for 2700 see flush bottom mount hardware

## Top Mount Package, Parallel Shaft Gearmotor

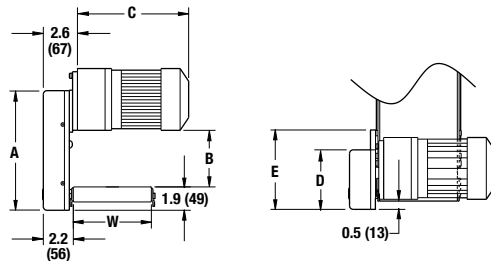
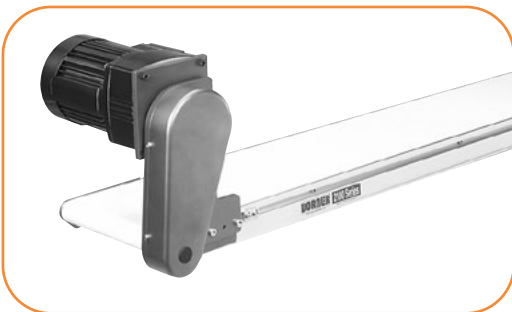

- Includes gearmotor mounting bracket, timing belt and pulleys, guard cover and mounting hardware

A: Light Load	= 226 (8.9)	C: Light Load, Fixed Speed and VFD Variable Speed	= 117 (4.6)
Standard Load	= 234 (9.2)	Light Load, DC Variable Speed	= 170 (6.7)
B: Light Load	= 100 (3.9)	Standard Load	= 267 (10.5)
Standard Load 2200	= 96 (3.8)	D: Light Load	= 142 (5.6)
Standard Load 2700	= 83 (3.3)	Standard Load 2200	= 116 (4.6)
		Standard Load 2700	= 103 (4.1)
		E: 2200	= 155 (6.1)
		2700	= 189 (7.4)

Note: Conveyor and gearmotor are not included in the mounting package and must be ordered separately. **W = Conveyor Belt Width** **Dim = mm (in)**

For ordering information, see page 66

## 2200 End Drive Belt Speed

Fixed Speed															
2200 Belt		2200 Precision Move		2200 Modular Belt				RPM From Gearmotor	Mount Package		Pulley Kit		Gearmotor Chart		
m/min	ft/min	m/min	ft/min	Micropitch Belts 01 and 02		Metalworking Belts 30 thru 42			Top & Bottom	Side	Drive Pulley	Driven Pulley	Light Load	Standard Load	Heavy Load
0.6	2	0.7	2.3	0.8	2.6	0.9	2.9	10	x		22	32		5	
0.9	3	1.1	3.5	1.2	3.9	1.3	4.3	10	x		28	28		5	
1.5	5	1.8	5.8	2.0	6.5	2.2	7.2	10	x		44	22		5	
1.8	6	2.1	6.9	2.4	7.8	2.6	8.6	29	x		19	32		4	12, 13
3.1	10	3.5	12	4.0	13.0	4.4	14.3	29	x	x	28	28		4, 5	12, 13
4.0	13	4.6	15	5.2	17	5.7	19	42	x		28	32	1		
4.6	15	5.3	17	5.9	20	6.5	21	42	x	x	28	28	1		
4.6	15	5.3	17	5.9	20	6.5	21	43	x	x	28	28		4, 19	12, 13
4.9	16	5.6	18	6.3	21	7.0	23	29	x		44	28		4, 5	12, 13
6.4	21	7.4	24	8.3	27	9.2	30	42	x		32	22	1		
7.3	24	8.4	28	9.5	31	10.5	34	43	x		44	28		4	12, 13
8.8	29	10.2	33	11.5	38	12.6	41	42	x		44	22	1		
9.2	30	10.5	35	11.9	39	13.1	43	86	x	x	28	28		4, 5	12, 13
10.7	35	12.3	40	13.9	46	15.3	50	100	x	x	28	28	1	19	
14.6	48	16.8	55	19.0	62	20.9	69	86	x		44	28		4, 5	12, 13
16.8	55	19.3	63	21.8	72	24.0	79	100	x		44	28	1		
18.6	61	21.4	70	24.2	79	26.6	87	173	x	x	28	28		4, 5	12, 13
29.0	95	33.3	109	37.7	124	41.4	136	173	x		44	28		4, 5	12, 13
31.7	104	36.5	120	41.2	135	45.4	149	173	x		48	28		4, 5	12, 13
36.9	121	42.4	139	48.0	157	52.8	173	345	x	x	28	28		4, 5	12, 13
42.1	138	48.4	159	54.7	179	60.2	197	345	x		32	28		4, 5	12, 13
53.7	176	61.7	202	69.8	229	76.8	252	345	x		32	22		4, 5	12, 13
63.4	208	73.0	239	82.5	270			345	x		48	28		4, 5	12, 13
73.8	242	84.9	278					345	x		44	22		4, 5	12, 13
80.5	264	92.6	304					345	x		48	22		4, 5	12, 13
Ⓢ Gearmotor RPM at 50 Hz.															
1.5	5	1.8	5.8	2.0	6.5	2.2	7.2	23*	x		19	32		6	
2.4	8	2.8	9.2	3.2	10.4	3.5	11.4	23*	x	x	28	28		6	
3.7	12	4.2	13.8	4.8	15.6	5.2	17.2	35*	x	x	28	28		6	
5.8	19	6.7	22	7.5	25	8.3	27	35*	x		44	28			
6.4	21	7.4	24	8.3	27	9.2	30	41*	x		32	22	2		
7.6	25	8.8	29	9.9	33	10.9	36	70*	x	x	28	28		6	
11.9	39	13.7	45	15.5	51	17.0	56	70*	x		44	28		6	
14.9	49	17.2	56	19.4	64	21.4	70	140*	x	x	28	28		6	
15.3	50	17.5	58	19.8	65	21.8	72	144*	x	x	28	28	2		
23.5	77	27.0	89	30.5	100	33.6	110	140*	x		44	28		6	
29.3	96	33.7	110	38.1	125	41.9	137	280*	x	x	28	28		6	
34.2	112	39.3	129	44.4	146	48.8	160	280*	x		32	28		6	
43.6	143	50.2	164	56.7	186	62.4	204	280*	x		32	22		6	
51.5	169	59.3	194	67.0	220	73.7	242	280*	x		48	28		6	
60.1	197	69.1	227	78.1	256			280*	x		44	22		6	
65.3	214	75.1	246					280*	x		48	22		6	
81.7	268	94.0	308					280*	x		60	22		6	

Cleated Belts operate at maximum 280 ft/min (86 m/min)

Red = Parallel Shaft, Blue = 90°

Other speeds available. See [www.dorner.com](http://www.dorner.com) and run the DTools program for a full list of belt speeds.

Refer to the Gearmotor Selection Steps on page 55 for instructions on using Belt Speed Charts

## 2700 End Drive Belt Speed

Fixed Speed								
2700 Belt		RPM From Gearmotor	Mount Package		Pulley Kit		Gearmotor Chart	
m/min	ft/min		Top & Bottom	Side	Drive Pulley	Driven Pulley	Standard Load	Heavy Load
1.9	6.2	10	x	x	28	28	5	
2.1	6.9	10	x		32	28	5	
2.8	9.2	10	x		48	32	5	
3.2	11	10	x		48	28	5	
5.5	18	29	x	x	28	28	4, 5	12
6.2	20	29	x		32	28	4, 5	12
8.1	27	43	x	x	28	28	4	12
8.2	27	29	x		48	32	4, 5	12
8.7	29	46	x	x	28	28	19	
9.3	31	43	x		32	28	4	12
9.4	31	29	x		48	28	4, 5	12
9.9	33	46	x		32	28	19	
11	36	58	x	x	28	28	5	
12	40	43	x		48	32	4, 5	12
13	41	58	x		32	28	5	
13	43	46	x		48	32	19	
14	46	43	x		48	28	4	12
15	49	46	x		48	28	19	
16	53	86	x	x	28	28	4, 5	12
16	54	58	x		48	32	5	
19	61	86	x		32	28	4, 5	12
19	61	58	x		48	28	5	
21	67	109	x	x	28	28	19	
24	77	109	x		32	28	19	
24	80	86	x		48	32	4, 5	12
28	91	86	x		48	28	4, 5	12
31	101	109	x		48	32	19	
33	107	173	x	x	28	28	4, 5	12
35	116	109	x		48	28	19	
37	122	173	x		32	28	4, 5	12
41	136	219	x	x	28	28	19	
47	155	219	x		32	28	19	
49	160	173	x		48	32	4, 5	12
56	183	173	x		48	28	4, 5	12
62	203	219	x		48	32	19	
65	213	345	x	x	28	28	4, 5	12
71	232	219	x		48	28	19	
74	244	345	x		32	28	4, 5	12
98	320	345	x		48	32	4, 5	12
111	366	345	x		48	28	4, 5	12
127	415	672	x	x	28	28		12
145	475	672	x		32	28		12
190	623	672	x		48	32		12
217	712	672	x		48	28		12
 Gearmotor RPM at 50 Hz.								
2.5	8.2	23	x		48	28	6	
2.9	9.5	23	x		48	32	6	
3.8	13	35	x		48	28	6	
3.8	13	23	x		32	28	6	
4.3	14	23	x	x	28	28	6	
4.4	14	35	x		48	32	6	
5.8	19	35	x		32	28	6	
6.6	22	35	x	x	28	28	6	
7.7	25	70	x		48	28	6	
8.8	29	70	x		48	32	6	
12	38	70	x		32	28	6	
13	43	70	x	x	28	28	6	
15	51	140	x		48	28	6	
18	58	140	x		48	32	6	
23	76	140	x		32	28	6	
26	87	140	x	x	28	28	6	
31	101	280	x		48	28	6	
35	116	280	x		48	32	6	
46	152	280	x		32	28	6	
53	173	280	x	x	28	28	6	

Cleated Belts operate at maximum 280 ft/min (86 m/min)  
 Red = Parallel Shaft, Blue = 90°

Other speeds available. See [www.dorner.com](http://www.dorner.com) and run the DTools program for a full list of belt speeds.

Refer to the Gearmotor Selection Steps on page 55 for instructions on using Belt Speed Charts

## 2200 End Drive Belt Speed

Variable Speed															
2200 Belt		2200 Precision Move		2200 Modular Belt				RPM From Gearmotor	Mount Package		Pulley Kit		Gearmotor Chart		
m/min	Ft/min	m/min	Ft/min	Micropitch Belts 01 and 02		Metalworking Belts 30 thru 42			Top & Bottom	Side	Drive Pulley	Driven Pulley	Light Load	Standard Load	Heavy Load
0.1 - 1	0.4 - 3.4	0.1 - 1.2	0.5 - 3.9	0.5 - 4.4	0.2 - 1.3	0.2 - 1.5	0.6 - 4.9	14	x		22	32		10	
0.2 - 1.5	0.6 - 5	0.2 - 1.8	0.7 - 5.8	0.8 - 6.5	0.2 - 2	0.3 - 2.2	0.9 - 7.2	14	x		28	28		10	
0.2 - 1.8	0.6 - 6	0.2 - 2.1	0.7 - 6.9	0.8 - 7.8	0.2 - 2.4	0.3 - 2.6	0.9 - 8.6	29	x		19	32		8	15, 16
0.3 - 3.1	1 - 10	0.4 - 3.5	1.2 - 11.5	1.3 - 13	0.4 - 4	0.4 - 4.4	1.4 - 14.3	29	x		28	28		8, 11	15, 16
0.5 - 4.3	1.8 - 14	0.6 - 4.9	2 - 16	2 - 18	0.7 - 5.6	0.8 - 6.1	2.6 - 20	42	x	x	28	28	3	7, 10, 20	14
0.5 - 4.6	1.5 - 15	0.5 - 5.3	2 - 17	2 - 20	0.6 - 5.9	0.7 - 6.5	2.1 - 21	43	x		28	28		9	15, 16
0.8 - 6.7	2.6 - 22	0.9 - 7.7	3 - 25	3 - 29	1 - 8.7	1.1 - 9.6	3.7 - 31	63	x	x	28	28		8	14
0.9 - 7	2.8 - 23	1 - 8	3 - 26	4 - 30	1.1 - 9.1	1.2 - 10	4 - 33	42	x		44	28	3	8	14
1.1 - 9	3.5 - 29	1.2 - 10	4 - 33	5 - 38	1.4 - 11.5	1.5 - 12.6	5 - 41	83	x		28	28		11	
0.9 - 9	3 - 30	1.1 - 11	3 - 35	4 - 39	1.2 - 11.9	1.3 - 13.1	4.3 - 43	86	x		28	28		8, 11	15, 16
1.6 - 13	5.3 - 44	1.9 - 15	6 - 51	7 - 57	2.1 - 17.4	2.3 - 19.2	7.6 - 63	125	x	x	28	28		7, 10, 20	14
1.8 - 15	6 - 49	2.1 - 17	7 - 56	8 - 64	2.4 - 19.4	2.6 - 21.4	8.6 - 70	139	x	x	28	28	3		
1.8 - 18	6 - 60	2.1 - 21	7 - 69	8 - 78	2.4 - 23.8	2.6 - 26.2	8.6 - 86	173	x		28	28		8, 11	15, 16
2.7 - 23	9 - 77	3.2 - 27	10 - 89	12 - 100	3.6 - 30.5	3.9 - 33.6	12.9 - 110	139	x		44	28	3		
3.1 - 27	10 - 88	3.5 - 31	12 - 101	13 - 114	4 - 34.9	4.4 - 38.4	14.3 - 126	250	x	x	28	28		7, 10	14
3.1 - 32	10 - 104	3.5 - 36	12 - 120	13 - 135	4 - 41.2	4.4 - 45.4	14.3 - 149	173	x		48	28		8, 11	15, 16
3.7 - 37	12 - 121	4.2 - 42	14 - 139	16 - 157	4.8 - 48	5.2 - 52.8	17.2 - 173	345	x		28	28		8, 11	15, 16
5.2 - 42	17 - 138	6 - 48	20 - 159	22 - 179	6.7 - 54.7	7.4 - 60.2	24.3 - 197	250	x		44	28		7, 10	14
6.4 - 54	21 - 176	7.4 - 62	24 - 202	27 - 229	8.3 - 69.8	9.2 - 76.8	30 - 252	500	x	x	28	28		7, 10	14
7.9 - 81	26 - 264	9.1 - 93	30 - 304					345	x		48	22		8, 11	15, 16
10.1 - 84	33 - 276	11.6 - 97	38 - 317					500	x		44	28		7, 10	14
CE Gearmotor															
0.7 - 1.8	2.4 - 6	0.8 - 2.1	2.8 - 6.9	1 - 2.4	3.1 - 7.8	1 - 2.6	3.4 - 8.6	39	x		19	32		9	
1.3 - 3.1	4.1 - 10	1.4 - 3.5	4.7 - 11.5	1.6 - 4	5.3 - 13	1.8 - 4.4	5.9 - 14.3	29	x	x	28	28		9	
1.8 - 4.6	6 - 15	2.1 - 5.3	6.9 - 17.3	2.4 - 5.9	7.8 - 19.5	2.6 - 6.5	8.6 - 21.5	44	x	x	28	28		9	
3.7 - 9.5	12 - 31	4.2 - 10.9	14 - 36	4.8 - 12	16 - 40	5 - 14	17 - 44	88	x	x	28	28		9	
7.6 - 18.9	25 - 62	8.8 - 21.7	29 - 71	9.9 - 25	33 - 81	11 - 27	36 - 89	176	x	x	28	28		9	
12 - 30	39 - 97	14 - 34	45 - 112	15.5 - 38	51 - 126	17 - 42	56 - 139	176	x		44	28		9	
15 - 38	49 - 124	17 - 43	56 - 143	19.4 - 49	64 - 161	21 - 54	70 - 177	353	x	x	28	28		9	
23 - 59	77 - 195	27 - 68	89 - 224	30.5 - 77	100 - 254	34 - 85	110 - 279	353	x		44	28		9	
33 - 82	107 - 270	38 - 95	123 - 311					353	x		48	22		9	

**Note:** Nose Bar transfers operate at maximum 23.5 m/min (77 ft/min) belt speed

Red = Parallel Shaft, Blue = 90°

Other speeds available. See [www.dorner.com](http://www.dorner.com) and run the DTools program for a full list of belt speeds.

Refer to the Gearmotor Selection Steps on page 55 for instructions on using Belt Speed Charts

## 2700 End Drive Belt Speed

Variable Speed								
2700 Belt		RPM From Gearmotor	Mount Package		Pulley Kit		Gearmotor Chart	
m/min	Ft/min		Top & Bottom	Side	Drive Pulley	Driven Pulley	Standard Load	Heavy Load
0.2 - 1.9	0.6 - 6.2	10	x	x	28	28	11	
0.2 - 2.1	0.7 - 6.9	10	x		32	28	11	
0.3 - 2.8	0.9 - 9.2	10	x		48	32	11	
0.3 - 3.2	1 - 11	10	x		48	28	11	
0.6 - 5.5	2 - 18	29	x	x	28	28	8, 11, 28	15, 29
0.6 - 6.2	2 - 20	29	x		32	28	8, 11, 28	15, 29
0.8 - 8.1	3 - 27	43	x	x	28	28	8, 28	15, 29
0.8 - 8.2	3 - 27	29	x		48	32	8, 11, 28	15, 29
0.9 - 8.7	3 - 29	46	x	x	28	28	20	
0.9 - 9.3	3 - 31	43	x		32	28	8, 28	15, 29
0.9 - 9.4	3 - 31	29	x		48	28	8, 11, 28	15, 29
1 - 9.9	3 - 33	46	x		32	28	20	
1 - 11	4 - 36	58	x	x	28	28	11	
1 - 11	4 - 37	60	x	x	28	28	26	
1 - 12	4 - 40	43	x		48	32	8, 28	15, 29
1 - 13	4 - 41	58	x		32	28	11	
1 - 13	4 - 42	60	x		32	28	26	
1 - 13	4 - 43	46	x		48	32	20	
1 - 14	5 - 46	43	x		48	28	8, 28	15, 29
2 - 15	5 - 49	46	x		48	28	20	
2 - 16	5 - 53	86	x	x	28	28	8, 11, 28	15, 29
2 - 16	5 - 54	58	x		48	32	11	
2 - 17	6 - 56	60	x		48	32	26	
2 - 19	6 - 61	86	x		32	28	8, 11, 28	15, 29
2 - 19	6 - 61	58	x		48	28	11	
2 - 19	6 - 64	60	x		48	28	26	
2 - 21	7 - 67	109	x	x	28	28	20	
2 - 24	8 - 77	109	x		32	28	20	
2 - 24	8 - 80	86	x		48	32	8, 11, 28	15, 29
3 - 28	9 - 91	86	x		48	28	8, 11, 28	15, 29
3 - 28	9 - 93	150	x	x	28	28	26	
3 - 31	10 - 101	109	x		48	32	20	
3 - 32	11 - 106	150	x		32	28	26	
3 - 33	11 - 107	173	x		32	32	8, 11, 28	15, 29
4 - 35	12 - 116	109	x		48	28	20	
4 - 37	12 - 122	173	x		32	28	8, 11, 28	15, 29
4 - 38	12 - 124	200	x	x	28	28	26	
4 - 41	14 - 136	219	x	x	28	28	20	
4 - 42	14 - 139	150	x		48	32	26	
4 - 43	14 - 141	200	x		32	28	26	
5 - 47	15 - 155	219	x		32	28	20	
5 - 48	16 - 159	150	x		48	28	26	
5 - 49	16 - 160	173	x		48	32	8, 11, 28	15, 29
6 - 56	18 - 183	173	x		48	28	8, 11, 28	15, 29
6 - 57	19 - 185	200	x		48	32	26	
6 - 62	20 - 203	219	x		48	32	20	
7 - 65	21 - 212	200	x		48	28	26	
7 - 65	21 - 213	345	x	x	28	28	8, 11, 28	15, 29
7 - 71	23 - 232	219	x		48	28	20	
7 - 74	24 - 244	345	x		32	28	8, 11, 28	15, 29
10 - 98	32 - 320	345	x		48	32	8, 11, 28	15, 29
11 - 111	37 - 366	345	x		48	28	8, 11, 28	15, 29
13 - 127	42 - 415	672	x	x	28	28		15
14 - 145	47 - 475	672	x		32	28		15
19 - 190	62 - 623	672	x		48	32		15
22 - 217	71 - 712	672	x		48	28		15

Variable Speed								
2700 Belt		RPM From Gearmotor	Mount Package		Pulley Kit		Gearmotor Chart	
m/min	Ft/min		Top & Bottom	Side	Drive Pulley	Driven Pulley	Standard Load	Heavy Load
<b>CE Gearmotor RPM at 50Hz.</b>								
0.6 - 5.5	2 - 18	29	x		28	28	9	
0.6 - 6.2	2 - 20	29	x		32	28	9	
0.8 - 8.2	3 - 27	29	x		48	32	9	
0.8 - 8.3	3 - 27	44	x		28	28	9	
0.9 - 9.4	3 - 31	29	x		48	28	9	
1 - 9.5	3 - 31	44	x		32	28	9	
1 - 12	4 - 41	44	x		48	32	9	
1 - 14	5 - 47	44	x		48	28	9	
2 - 17	6 - 55	88	x		28	28	9	
2 - 19	6 - 62	88	x		32	28	9	
3 - 25	8 - 82	88	x		48	32	9	
3 - 28	9 - 93	88	x		48	28	9	
3 - 33	11 - 109	176	x		28	28	9	
4 - 38	12 - 124	176	x		32	28	9	
5 - 50	16 - 163	176	x		48	32	9	
6 - 57	19 - 186	176	x		48	28	9	
7 - 67	22 - 218	353	x		28	28	9	
8 - 76	25 - 249	353	x		32	28	9	
10 - 100	33 - 327	353	x		48	32	9	
11 - 114	37 - 374	353	x		48	28	9	

**Note:** Nose Bar transfers operate at maximum 23.5 m/min (77 ft/min) belt speed  
**Red** = Parallel Shaft, **Blue** = 90°

Other speeds available. See [www.dorner.com](http://www.dorner.com) and run the DTools program for a full list of belt speeds.

Refer to the Gearmotor Selection Steps on page 55 for instructions on using Belt Speed Charts

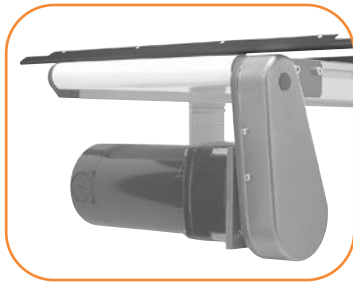

### Product Applications/Uses:

- Wide product transfers
- Product stops/escapements
- Product detection
- Lift stations
- Sheet handling

## Flush Bottom Mount Package, Parallel Shaft Gearmotor

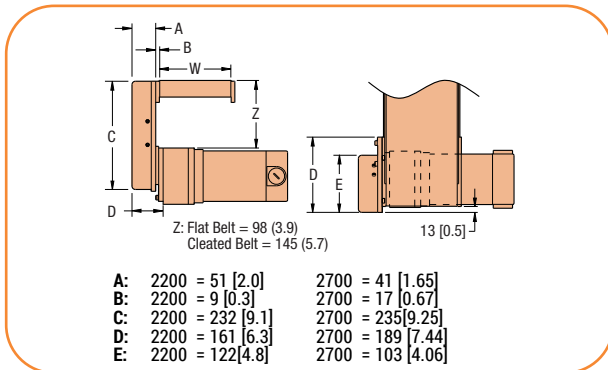

**Standard Load**

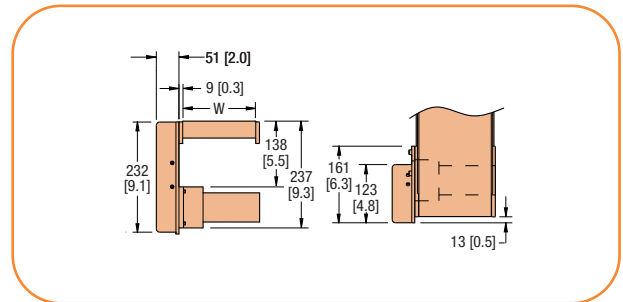

**Light Load (2200 only)**

## Flush Bottom Mount Package, 90° Gearmotor

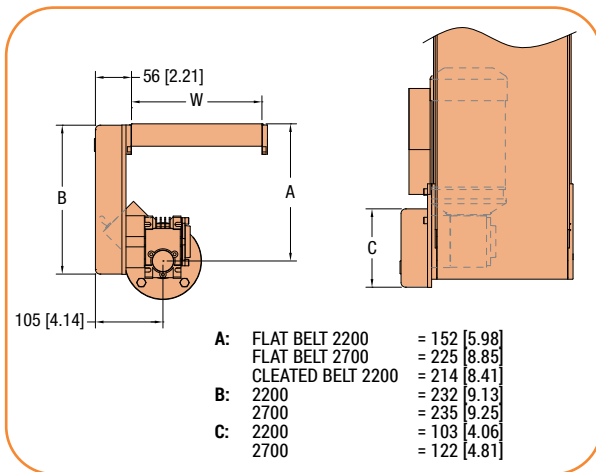

**Standard Load**

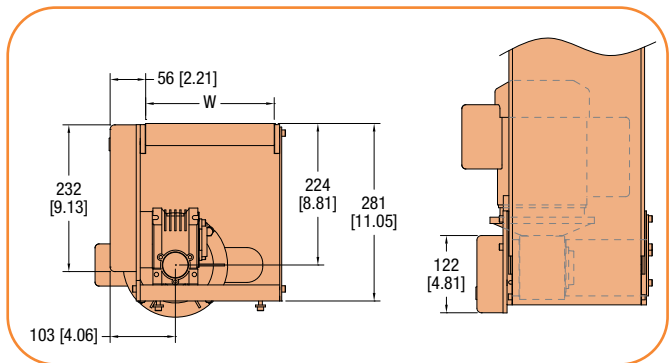

**Heavy Load (2200 only)**

Dim = mm (in)

Refer to the Gearmotor Selection Steps on page 55 for instructions on using Belt Speed Charts

## 2200 Flush Bottom Belt Speed

Fixed Speed													
2200 Belt		2200 Precision Move		2200 Modular Belt				RPM From Gearmotor	Pulley Kit		Gearmotor Chart		
				Micropitch Belts 01 and 02		Metalworking Belts 30 thru 42			Drive Pulley	Driven Pulley	Light Load	Standard Load	Heavy Load
m/min	ft/min	m/min	ft/min	m/min	ft/min	m/min	ft/min						
1.8	5.9	2.1	6.8	2.3	7.7	2.6	8.4	10	28	16		5	
3.1	10.1	3.7	12	4.0	13.1	4.4	14.4	10	48	16		5	
5.5	18	6.4	21	7.1	23	7.9	26	29	28	16		4, 5	12, 13
8.5	28	9.8	32	11.1	36	12.2	40	29	44	16		4, 5	12, 13
7.6	25	8.8	29	9.9	33	10.9	36	42	28	16	1		
12.2	40	14	46	16	52	17.4	57	42	44	16	1		
12.5	41	14.3	47	16.3	53	17.9	59	43	44	16		4, 19	12, 13
16.8	55	19.2	63	21.8	72	24.0	79	58	44	16		5	
25.3	83	29.0	95	32.9	108	36.2	119	86	44	16		4, 5	12, 13
32.3	106	37.2	122	42.0	138	46.2	152	173	28	16	1	4, 5	12, 13
50.9	167	58.6	192	66.2	217	72.8	239	173	44	16		4, 5	12, 13
64.7	212	74.4	244					345	28	16	1	4, 5	12, 13
Ⓢ Ⓢ Gearmotor RPM at 50 Hz.													
4.3	14	4.9	16	5.6	18	5.6	18	23	28	16		6	
7.0	23	8.1	26	9.1	30	9.1	30	23	44	16		6	
10.4	34	11.9	39	13.5	44	13.5	44	35	44	16		6	
7.6	25	8.8	29	9.9	33	9.9	33	41	28	16	2		
11.9	39	13.7	45	15.5	51	15.5	51	41	44	16	2		
13.1	43	15.1	49	17.0	56	17.0	56	70	28	16		6	
20.4	67	23.5	77	26.6	87	26.6	87	70	44	16		6	
26.2	86	30.2	99	34.1	112	34.1	112	140	28	16		6	
41.2	135	47.4	155	53.5	176	53.5	176	140	44	16		6	
52.5	172	60.3	198	68.2	224	68.2	224	280	28	16		6	
82.4	270	94.7	311					280	44	16		6	

Variable Speed													
2200 Belt		2200 Precision Move		2200 Modular Belt				RPM From Gearmotor	Pulley Kit		Gearmotor Chart		
				Micropitch Belts 01 and 02		Metalworking Belts 30 thru 42			Drive Pulley	Driven Pulley	Light Load	Standard Load	Heavy Load
m/min	ft/min	m/min	ft/min	m/min	ft/min	m/min	ft/min						
0.5 - 4	1.6 - 13	0.6 - 4.6	1.8 - 15	1 - 5	2 - 17	1 - 6	2 - 19	14	44	16		10	
0.9 - 8.5	2.8 - 28	1 - 9.8	3.2 - 32.2	1 - 11	4 - 36	1 - 12	4 - 40	29	44	16		8, 11	15, 16
1 - 8	3.1 - 26	1 - 9	4 - 30	1 - 10	4 - 34	1 - 11	4 - 37	42	28	16	3	7, 10	14
1 - 12	4.8 - 40	2 - 14	6 - 46	2 - 16	6 - 52	2 - 17	7 - 57	42	44	16	3	7, 10	14
1 - 13	4.2 - 42	1 - 15	5 - 48	2 - 17	5 - 55	2 - 18	6 - 60	43	44	16		8, 20	15, 16
2 - 18	7 - 60	2 - 21	8 - 69	3 - 24	9 - 78	3 - 26	10 - 86	63	44	16		7	14
3 - 25	10 - 81	4 - 28	12 - 93	4 - 32	13 - 105	4 - 35	14 - 116	83	44	16		10	
2 - 25	8 - 83	3 - 29	9 - 95	3 - 33	10 - 108	3 - 36	11 - 119	86	44	16		8, 11	15, 16
4 - 37	14 - 121	5 - 42	16 - 139	6 - 48	18 - 157	6 - 53	20 - 173	125	44	16		7, 10	14
3 - 26	10 - 85	4 - 30	12 - 98	4 - 34	13 - 111	4 - 37	14 - 122	139	28	16	3		
5 - 54	17 - 177	6 - 62	20 - 204	7 - 70	22 - 230	7 - 77	24 - 253	173	44	16		8, 11	15, 16
6 - 65	21 - 212	7 - 74	24 - 244					345	28	16		8, 11	15, 16
9 - 74	29 - 241	10 - 85	33 - 277					250	44	16		7, 10	14
Ⓢ Ⓢ Gearmotor													
2.1 - 5.5	7 - 18	2.5 - 6.3	8.1 - 20.7	3 - 7	9 - 23	3 - 8	10 - 26	29	28	16		9	
3.4 - 8.5	11 - 28	3.9 - 9.8	12.7 - 32.2	4 - 11	14 - 36	5 - 12	16 - 40	29	44	16		6	
5 - 13	17 - 43	6 - 15	20 - 49	7 - 17	22 - 56	7 - 19	24 - 61	44	44	16		6	
10 - 26	34 - 85	12 - 30	39 - 98	13 - 34	44 - 111	15 - 37	49 - 122	88	44	16		9	
13 - 33	43 - 108	15 - 38	49 - 124	17 - 43	56 - 140	19 - 47	61 - 154	176	28	16		9	
21 - 52	68 - 170	24 - 60	78 - 196	27 - 67	88 - 221	30 - 74	97 - 243	176	44	16		6	
26 - 66	86 - 216	30 - 76	99 - 248					353	28	16		6	

Red = Parallel Shaft, Blue = 90°

Refer to the Gearmotor Selection Steps on page 55 for instructions on using Belt Speed Charts

Other speeds available. See [www.dorner.com](http://www.dorner.com) and run the DTools program for a full list of belt speeds.

## Gang Mid Drive Belt Speed Charts

Fixed Speed				
2200 Precision Move		RPM From Gearmotor	Gearmotor Chart	
m/min	Ft/min		Standard Load	Heavy Load
4.6	15	29	4	12
7.0	23	43	4	12
13.7	45	86	4	12
27.8	91	173	4	12
55.2	181	345	4	12
CE Gearmotor RPM at 50 Hz.				
3.7	12	23	6	
5.5	18	35	6	
11.3	37	70	6	
22.3	73	140	6	
44.8	147	280	6	

Variable Speed				
2200 Precision Move		RPM From Gearmotor	Gearmotor Chart	
m/min	Ft/min		Standard Load	Heavy Load
0.6 - 4.6	2 - 15	29	8	15
0.9 - 6.7	3 - 22	42	7	14
0.9 - 7	3 - 23	43	8	15
1.2 - 10.1	4 - 33	63	7	14
1.5 - 13.7	5 - 45	86	8	15
2.1 - 20.1	7 - 66	125	7	14
2.7 - 27.8	9 - 91	173	8	15
4 - 40	13 - 131	250	7	14
5.5 - 55.2	18 - 181	345	8	15
7.9 - 79.9	26 - 262	500	7	14
CE RPM from CE/50 Hz gearmotors VFD drive at 63 Max. Hz. output				
1.8 - 4.6	6 - 15	29	9	
2.7 - 7	9 - 23	44	9	
5.8 - 14.3	19 - 47	88	9	
11.3 - 28.1	37 - 92	176	9	
22.6 - 56.4	74 - 185	353	9	

Red = Parallel Shaft, Blue = 90°

# 2200/2700 SERIES CENTER & MID DRIVE MOUNTING PACKAGES

## 2200 Series Bottom, Top & Flush Mount End Drive Mounting Package

2 2 M B P S 06 A - 2828

- Drive / Driven Pulley Combination (Top and Bottom mounts only)
- Belt Style: "-" = Flat Belt or add Cleat Type: A, B, C, F, G, H, J, V
- Gearmotor Mounting Position: A, B, C, D
- Conveyor Width Reference
- Gearmotor Type: L, A, V, S, B, H, K
- Gearmotor Output Shaft: P = Parallel Shaft E = eDrive® 90° W = Sew 90°
- Mount Style: B = Bottom Mount T = Top Mount F = Flush Bottom Mount
- Documentation Language: M = US, U = Europe

## 2200 Series Side Mount End Drive Motor Mounting Package

2 2 M S E S A T

- T = High Torque (not available for L or V)
- Position: A, B, C, D
- Gearmotor Type: L, V, S, H, K
- Gearmotor Output Shaft: P = Parallel Shaft E = eDrive® 90° W = Sew 90°
- Mount Style: S = Side
- Documentation Language: M = US, U = Europe

### BELT DRIVE SHAFT POSITION

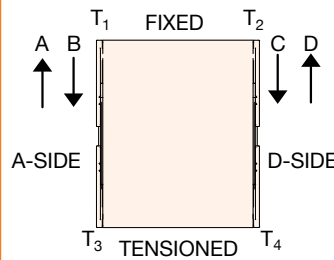

Since belts are being pulled, positions A & D are preferred. Pushing belts (B & C) reduce conveyor load capacity by approximately 66%.

### MODULAR BELT DRIVE SHAFT POSITION

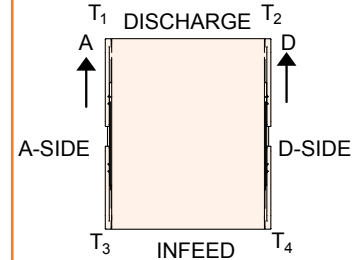

## 2200 Precision Move Gang Drive Side Mounting Package

2 2 M G E S - WW O G G A

- Position: A or D
- End Guard Length: (00 to 20)
- Conveyor Quantity: D = Double T = Triple
- Distance Between Outer Conveyor Edges (05 to 48)
- Load Type: S = Standard H = Heavy K = Standard VFD
- Shaft Type: E = eDrive®
- Documentation Language: M = US, U = Europe

## 2700 Series Drive Mount Packages

2 L M B P S A - 3 2 3 2

- Drive / Driven Pulley Combination pulley options see note
- Controls/Flow/Drive Shaft Position: A, B, C or D A or D only for MID drive
- Gearmotor Type: S = Standard Load, H = Heavy Load
- Gearmotor Output Shaft: P = Parallel, E = eDrive 90, W = Sew 90
- Mount Style: B = Bottom Mount, T = Top Mount, S = Side Mount, N = MID drive Side Mount, M = MID drive Bottom Mount
- Documentation Language: M = US, U = Europe
- Prefix: 2L = End drive mount packages for 2700 Product

For Universal Drive, see page 56

# CENTER & MID DRIVE BELT SPEED CHARTS 2200/2700 SERIES

## Center Drive (2200 Series ONLY)

### TYPE 1 - Vertical Mount

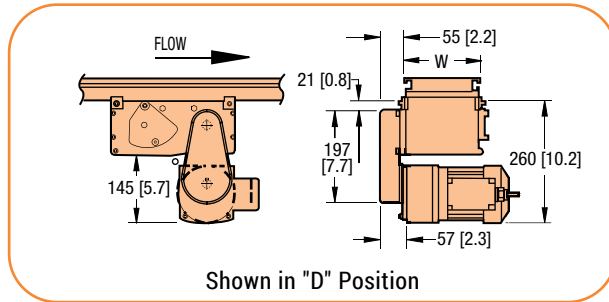

Shown in "D" Position

#### Parallel Shaft Gearmotor

### TYPE 2 - Horizontal Mount

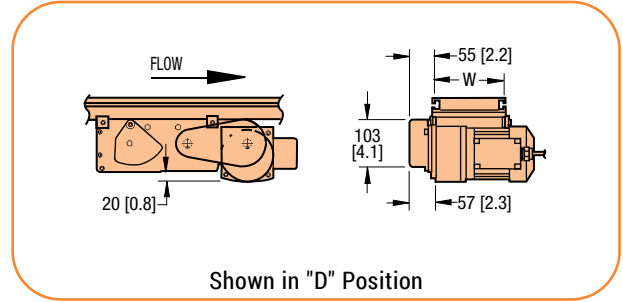

Shown in "D" Position

#### Parallel Shaft Gearmotor

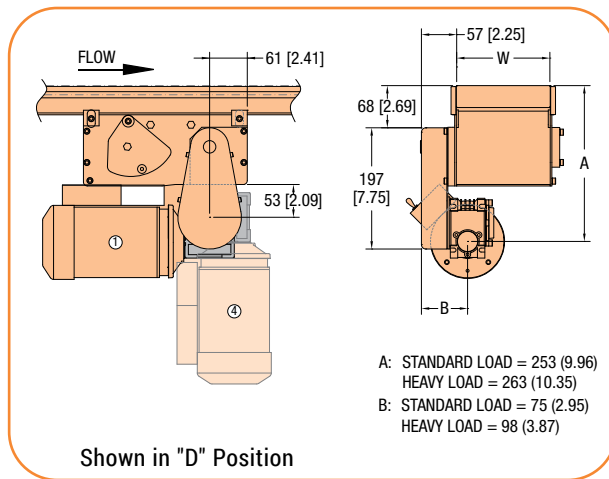

Shown in "D" Position

#### 90° Gearmotor

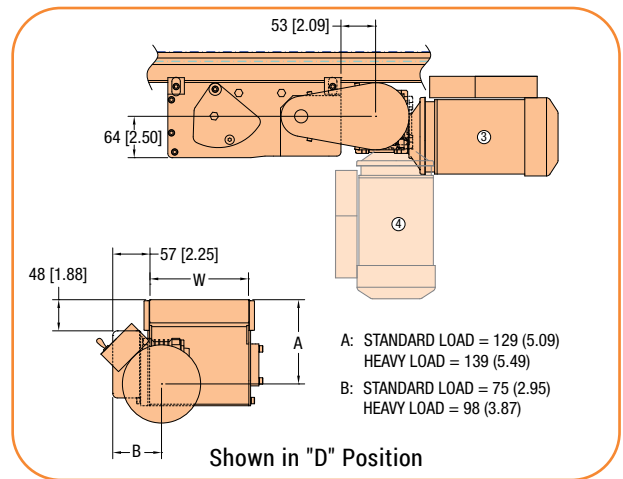

Shown in "D" Position

#### 90° Gearmotor

Standard position shown, can be reconfigured to alternative phantom position.

TYPE 2 recommended for tight spaces and allows for easy access to the drive module.

\* Gearmotor not included in mounting package, see page 47 for gearmotor ordering information.

## Mid Drive, Bottom Mount

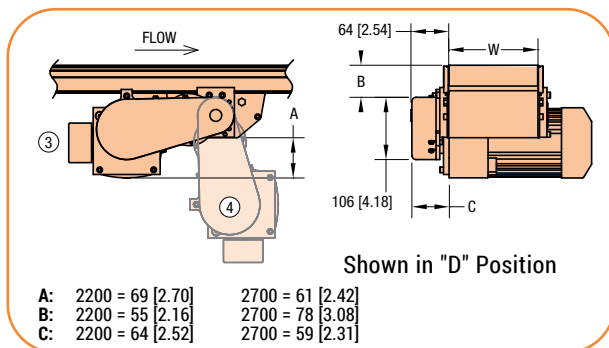

Shown in "D" Position

#### Parallel Shaft Gearmotor

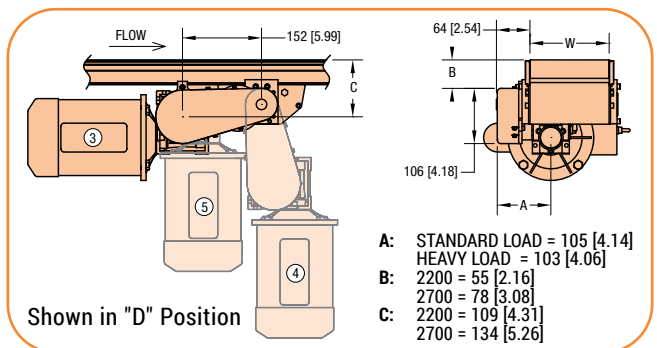

Shown in "D" Position

#### 90° Gearmotor

Standard position shown, can be reconfigured to alternative phantom position.

Dim = mm (in)

For ordering information, see page 72

Refer to the Gearmotor Selection Steps on page 55 for instructions on using Belt Speed Charts

# 2200/2700 SERIES CENTER & MID DRIVE BELT SPEED CHARTS

## Mid Drive, Side Mount

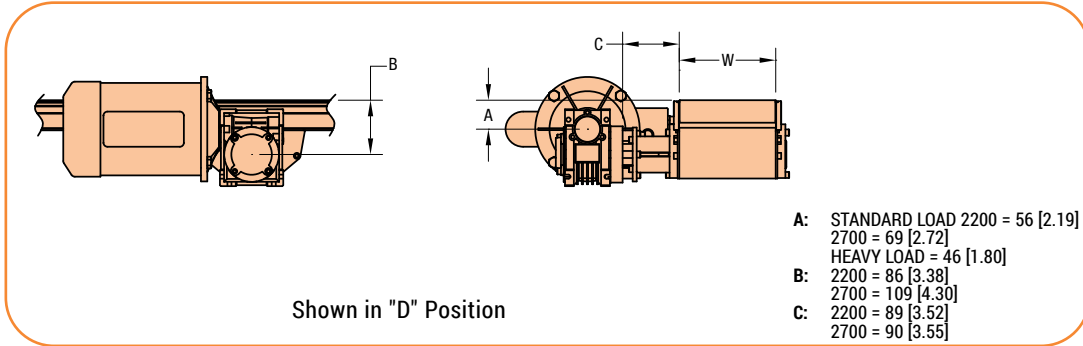

90° Gearmotor

## 2200 Center & Mid Drive Belt Speed

Fixed Speed													
2200 Belt		2200 Precision Move		2200 Modular Belt				RPM From Gearmotor	Side Drive	Pulley Kit		Gearmotor Chart	
				Micropitch Belts 01 and 02		Metalworking Belts 30 thru 42				Drive Pulley	Driven Pulley	Standard Load	Heavy Load
m/min	ft/min	m/min	ft/min	m/min	ft/min	m/min	ft/min						
0.6	2	0.9	3.1	0.8	2.6	0.9	2.9	10		22	32	5	
0.9	3	1.4	4.6	1.2	3.9	1.3	4.3	10	x	32	32	5	
1.8	6	2.8	9.2	2.4	7.8	2.6	8.6	29		19	32	4	11, 12
3.1	10	4.7	15.3	4.0	13.0	4.4	14.3	29	x	32	32	4, 5	11, 12
4.6	15	7.0	23	5.9	20	6.5	21	43	x	32	32	4, 19	11, 12
6.1	20	9.3	31	7.9	26	8.7	29	58	x	32	32	5	
7.0	23	10.7	35	9.1	30	10.0	33	43		48	32	4	11, 12
9.2	30	14.0	46	11.9	39	13.1	43	86	x	32	32	4, 5	11, 12
18.6	61	28.5	93	24.2	79	26.6	87	173	x	32	32	4, 5	11, 12
27.8	91	42.5	139	36.1	118	39.7	130	173		48	32	4, 5	11, 12
36.9	121	56.5	185	48.0	157	52.8	173	345	x	32	32	4, 5	11, 12
47.0	154	71.9	236	61.1	200	67.2	220	345		28	22	4, 5	11, 12
55.2	181	84.5	277	71.8	235	78.9	259	345		48	28	4, 5	11, 12
63.4	208	97.1	318					345		48	28	4, 5	11, 12
80.5	264	123.2	404					345		48	22	4, 5	11, 12
⌚ Gearmotor RPM at 50 Hz.													
1.5	5	2.3	7.7	2.0	6.5	2.2	7.2	23		19	32	6	
2.4	8	3.7	12.2	3.2	10.4	3.5	11.4	23	x	32	32	6	
3.7	12	5.6	18.4	4.8	15.6	5.2	17.2	35	x	32	32	6	
5.5	18	8.4	27.5	7.1	23	7.9	26	35		48	32	6	
7.6	25	11.7	38	9.9	33	10.9	36	70	x	32	32	6	
11.3	37	17.3	57	14.7	48	16.1	53	70		48	32	6	
14.9	49	22.9	75	19.4	64	21.4	70	140	x	32	32	6	
22.6	74	34.5	113	29.3	96	32.3	106	140		48	32	6	
29.9	98	45.7	150	38.9	127	42.7	140	280	x	32	32	6	
45.1	148	69.1	226	58.7	192	64.6	212	280		48	32	6	
51.5	169	78.9	259	67.0	220	73.7	242	280		48	28	6	
65.3	214	99.9	327					280		48	22	6	
75.6	248	115.7	379					280		48	19	6	

Note: Nose Bar transfers operate at maximum 23.5 m/min (77 ft/min) belt speed  
 Red = Parallel Shaft, Blue = 90°

Dim = mm (in)

# CENTER & MID DRIVE BELT SPEED CHARTS **2200/2700 SERIES**

## 2200 Center & Mid Drive Belt Speed

Variable Speed															
2200 Belt		2700 Belt		2200 Precision Move		2200 Modular Belt				RPM From Gearmotor	Side Drive	Pulley Kit		Gearmotor Chart	
m/min	ft/min	m/min	ft/min	m/min	ft/min	Microptich Belts 01 and 02		Metalworking Belts 30 thru 42				Drive Pulley	Driven Pulley	Standard Load	Heavy Load
0.1 - 1	0.4 - 3.4	0.1 - 1	0.4 - 3.4	0.2 - 1.6	0.6 - 5.2	0.2 - 1.3	0.5 - 4.4	0.2 - 1.5	0.6 - 4.9	14		22	32	10	
0.2 - 1.5	0.6 - 4.9	0.2 - 1.5	0.6 - 4.9	0.3 - 2.3	0.9 - 7.5	0.2 - 1.9	0.8 - 6.4	0.3 - 2.1	0.9 - 7	14	x	32	32	10	
0.2 - 1.8	0.7 - 6	0.2 - 1.8	0.7 - 6	0.3 - 2.8	1.1 - 9.2	0.3 - 2.4	0.9 - 7.8	0.3 - 2.6	1 - 8.6	29		19	32	8	15, 16
0.3 - 2.7	1 - 9	0.3 - 2.7	1 - 9	0.5 - 4.2	1.5 - 13.8	0.4 - 3.6	1.3 - 11.7	0.4 - 3.9	1.4 - 12.9	42		19	32	7, 10	14
0.4 - 3.1	1.2 - 10	0.4 - 3.1	1.2 - 10	0.6 - 4.7	1.8 - 15.3	0.5 - 4	1.6 - 13	0.5 - 4.4	1.7 - 14.3	29	x	32	32	8, 11	15, 16
0.5 - 4.6	1.8 - 15	0.5 - 4.6	1.8 - 15	0.8 - 7	2.8 - 23	1 - 6	2 - 20	1 - 7	3 - 21	42	x	32	32	7, 10	14
0.5 - 4.6	1.8 - 15	0.5 - 4.6	1.8 - 15	0.8 - 7	2.8 - 23	1 - 6	2 - 20	1 - 7	3 - 21	43	x	32	32	8, 20	15, 16
0.8 - 6.7	2.6 - 22	0.8 - 6.7	2.6 - 22	1.2 - 10.3	4 - 33.7	1 - 9	3 - 29	1 - 10	4 - 31	63	x	32	32	7	14
1.1 - 9	3.5 - 29	1.1 - 9	3.5 - 29	2 - 14	5 - 44	1 - 11	5 - 38	2 - 13	5 - 41	83	x	32	32	10	
1.1 - 9	3.6 - 30	1.1 - 9	3.6 - 30	2 - 14	6 - 46	1 - 12	5 - 39	2 - 13	5 - 43	86	x	32	32	8, 11	15, 16
1.6 - 13	5.3 - 44	1.6 - 13	5.3 - 44	2 - 21	8 - 67	2 - 17	7 - 57	2 - 19	8 - 63	125	x	32	32	7, 10	14
2.1 - 19	7 - 61	2.1 - 19	7 - 61	3 - 28	11 - 93	3 - 24	9 - 79	3 - 27	10 - 87	173	x	32	32	8, 11	15, 16
3.1 - 27	10 - 88	3.1 - 27	10 - 88	5 - 41	15 - 135	4 - 35	13 - 114	4 - 38	14 - 126	250	x	32	32	7, 10	14
3.7 - 32	12 - 104	3.7 - 32	12 - 104	6 - 49	18 - 159	5 - 41	16 - 135	5 - 45	17 - 149	173		48	28	8, 11	15, 16
4.3 - 37	14 - 121	4.3 - 37	14 - 121	7 - 56	21 - 185	6 - 48	18 - 157	6 - 53	20 - 173	345	x	32	32	8, 11	15, 16
5.5 - 46	18 - 150	5.5 - 46	18 - 150	8 - 70	28 - 230	7 - 59	23 - 195	8 - 65	26 - 215	250		48	28	7, 10	14
6.4 - 54	21 - 176	6.4 - 54	21 - 176	10 - 82	32 - 269	8 - 70	27 - 229	9 - 77	30 - 252	500	x	32	32	7, 10	14
7 - 58	23 - 190	7 - 58	23 - 190	11 - 89	35 - 291	9 - 75	30 - 247			345		44	28	8, 11	15, 16
8.2 - 68	27 - 224	8.2 - 68	27 - 224	13 - 105	41 - 343					500		28	22	7, 10	14
8.8 - 74	29 - 242	8.8 - 74	29 - 242	14 - 113	44 - 370					345		44	22	8, 11	15, 16
9.5 - 78	31 - 255	9.5 - 78	31 - 255	14 - 119	47 - 390					500		32	22	7, 10	14
 gearmotors, VFD drive at 63 max. Hz. output.															
0.7 - 1.8	2.4 - 6	0.7 - 1.8	2.4 - 6	1.1 - 2.8	3.7 - 9.2	1 - 2.4	3.1 - 7.8	1 - 2.6	3.4 - 8.6	29		19	32	9	
1.3 - 3.1	4.1 - 10	1.3 - 3.1	4.1 - 10	1.9 - 4.7	6.3 - 15.3	1.6 - 4	5.3 - 13	1.8 - 4.4	5.9 - 14.3	29	x	32	32	9	
1.8 - 4.9	6 - 16	1.8 - 4.9	6 - 16	2.8 - 7.5	9.2 - 24.5	2.4 - 6.3	8 - 21	2.6 - 7	8.6 - 22.9	44	x	32	32	9	
3.7 - 9	12 - 31	3.7 - 9	12 - 31	6 - 14	18 - 47	5 - 12	16 - 40	5 - 14	17 - 44	88	x	32	32	9	
7.3 - 19	24 - 62	7.3 - 19	24 - 62	11 - 29	37 - 95	10 - 25	31 - 81	10 - 27	34 - 89	176	x	32	32	9	
11.3 - 28	37 - 93	11.3 - 28	37 - 93	17 - 43	57 - 142	15 - 37	48 - 121	16 - 41	53 - 133	176		48	32	9	
14.9 - 38	49 - 124	14.9 - 38	49 - 124	23 - 58	75 - 190	19 - 49	64 - 161	21 - 54	70 - 177	353	x	32	32	9	
22.6 - 57	74 - 186	22.6 - 57	74 - 186	35 - 87	113 - 285	29 - 74	96 - 242	32 - 81	106 - 266	355		48	32	9	
29.9 - 76	98 - 248	29.9 - 76	98 - 248	46 - 116	150 - 379					353		44	22	9	

**Note:** Nose Bar transfers operate at maximum 23.5 m/min (77 ft/min) belt speed

Red = Parallel Shaft, Blue = 90°

Refer to the Gearmotor Selection Steps on page 55 for instructions on using Belt Speed Charts

# 2200/2700 SERIES CENTER & MID DRIVE BELT SPEED CHARTS

## 2700 Mid Drive Belt Speed

Fixed Speed								
2700 Belt		RPM From Gearmotor	Mount Package		Pulley Kit		Gearmotor Chart	
m/min	ft/min		Top & Bottom	Side	Drive Pulley	Driven Pulley	Standard Load	Heavy Load
1.9	6.2	10	x	x	28	28	5	
2.1	6.9	10	x		32	28	5	
2.8	9.2	10	x		48	32	5	
3.2	11	10	x		48	28	5	
5.5	18	29	x	x	28	28	4, 5	12
6.2	20	29	x		32	28	4, 5	12
8.1	27	43	x	x	28	28	4	12
8.2	27	29	x		48	32	4, 5	12
8.7	29	46	x	x	28	28	19	
9.3	31	43	x		32	28	4	12
9.4	31	29	x		48	28	4, 5	12
9.9	33	46	x		32	28	19	
11	36	58	x	x	28	28	5	
12	40	43	x		48	32	4, 5	12
13	41	58	x		32	28	5	
13	43	46	x		48	32	19	
14	46	43	x		48	28	4	12
15	49	46	x		48	28	19	
16	53	86	x	x	28	28	4, 5	12
16	54	58	x		48	32	5	
19	61	86	x		32	28	4, 5	12
19	61	58	x		48	28	5	
21	67	109	x	x	28	28	19	
24	77	109	x		32	28	19	
24	80	86	x		48	32	4, 5	12
28	91	86	x		48	28	4, 5	12
31	101	109	x		48	32	19	
33	107	173	x	x	28	28	4, 5	12
35	116	109	x		48	28	19	
37	122	173	x		32	28	4, 5	12
41	136	219	x	x	28	28	19	
47	155	219	x		32	28	19	
49	160	173	x		48	32	4, 5	12
56	183	173	x		48	28	4, 5	12
62	203	219	x		48	32	19	
65	213	345	x	x	28	28	4, 5	12
71	232	219	x		48	28	19	
74	244	345	x		32	28	4, 5	12
98	320	345	x		48	32	4, 5	12
111	366	345	x		48	28	4, 5	12
127	415	672	x	x	28	28		12
145	475	672	x		32	28		12
190	623	672	x		48	32		12
217	712	672	x		48	28		12
 Gearmotor RPM at 50 Hz.								
2.5	8.2	23	x		48	28	6	
2.9	9.5	23	x		48	32	6	
3.8	13	35	x		48	28	6	
3.8	13	23	x		32	28	6	
4.3	14	23	x	x	28	28	6	
4.4	14	35	x		48	32	6	
5.8	19	35	x		32	28	6	
6.6	22	35	x	x	28	28	6	
7.7	25	70	x		48	28	6	
8.8	29	70	x		48	32	6	
12	38	70	x		32	28	6	
13	43	70	x	x	28	28	6	
15	51	140	x		48	28	6	
18	58	140	x		48	32	6	
23	76	140	x		32	28	6	
26	87	140	x	x	28	28	6	
31	101	280	x		48	28	6	
35	116	280	x		48	32	6	
46	152	280	x		32	28	6	
53	173	280	x	x	28	28	6	

Cleated Belts operate at maximum 280 ft/min (86 m/min)  
 Red = Parallel Shaft, Blue = 90°

Other speeds available. See [www.dorner.com](http://www.dorner.com) and run the DTools program for a full list of belt speeds.

Refer to the Gearmotor Selection Steps on page 55 for instructions on using Belt Speed Charts

# CENTER & MID DRIVE BELT SPEED CHARTS **2200/2700 SERIES**

## 2700 Mid Drive Belt Speed

Variable Speed								
2700 Belt		RPM From Gearmotor	Mount Package		Pulley Kit		Gearmotor Chart	
m/min	Ft/min		Top & Bottom	Side	Drive Pulley	Driven Pulley	Standard Load	Heavy Load
0.2 - 1.9	0.6 - 6.2	10	x	x	28	28	11	
0.2 - 2.1	0.7 - 6.9	10	x		32	28	11	
0.3 - 2.8	0.9 - 9.2	10	x		48	32	11	
0.3 - 3.2	1 - 11	10	x		48	28	11	
0.6 - 5.5	2 - 18	29	x	x	28	28	8, 11, 28	15, 29
0.6 - 6.2	2 - 20	29	x		32	28	8, 11, 28	15, 29
0.8 - 8.1	3 - 27	43	x	x	28	28	8, 28	15, 29
0.8 - 8.2	3 - 27	29	x		48	32	8, 11, 28	15, 29
0.9 - 8.7	3 - 29	46	x	x	28	28	20	
0.9 - 9.3	3 - 31	43	x		32	28	8, 28	15, 29
0.9 - 9.4	3 - 31	29	x		48	28	8, 11, 28	15, 29
1 - 9.9	3 - 33	46	x		32	28	20	
1 - 11	4 - 36	58	x	x	28	28	11	
1 - 11	4 - 37	60	x	x	28	28	26	
1 - 12	4 - 40	43	x		48	32	8, 28	15, 29
1 - 13	4 - 41	58	x		32	28	11	
1 - 13	4 - 42	60	x		32	28	26	
1 - 13	4 - 43	46	x		48	32	20	
1 - 14	5 - 46	43	x		48	28	8, 28	15, 29
2 - 15	5 - 49	46	x		48	28	20	
2 - 16	5 - 53	86	x	x	28	28	8, 11, 28	15, 29
2 - 16	5 - 54	58	x		48	32	11	
2 - 17	6 - 56	60	x		48	32	26	
2 - 19	6 - 61	86	x		32	28	8, 11, 28	15, 29
2 - 19	6 - 61	58	x		48	28	11	
2 - 19	6 - 64	60	x		48	28	26	
2 - 21	7 - 67	109	x	x	28	28	20	
2 - 24	8 - 77	109	x		32	28	20	
2 - 24	8 - 80	86	x		48	32	8, 11, 28	15, 29
3 - 28	9 - 91	86	x		48	28	8, 11, 28	15, 29
3 - 28	9 - 93	150	x	x	28	28	26	
3 - 31	10 - 101	109	x		48	32	20	
3 - 32	11 - 106	150	x		32	28	26	
3 - 33	11 - 107	173	x		32	32	8, 11, 28	15, 29
4 - 35	12 - 116	109	x		48	28	20	
4 - 37	12 - 122	173	x		32	28	8, 11, 28	15, 29
4 - 38	12 - 124	200	x	x	28	28	26	
4 - 41	14 - 136	219	x	x	28	28	20	
4 - 42	14 - 139	150	x		48	32	26	
4 - 43	14 - 141	200	x		32	28	26	
5 - 47	15 - 155	219	x		32	28	20	
5 - 48	16 - 159	150	x		48	28	26	
5 - 49	16 - 160	173	x		48	32	8, 11, 28	15, 29
6 - 56	18 - 183	173	x		48	28	8, 11, 28	15, 29
6 - 57	19 - 185	200	x		48	32	26	
6 - 62	20 - 203	219	x		48	32	20	
7 - 65	21 - 212	200	x		48	28	26	
7 - 65	21 - 213	345	x	x	28	28	8, 11, 28	15, 29
7 - 71	23 - 232	219	x		48	28	20	
7 - 74	24 - 244	345	x		32	28	8, 11, 28	15, 29
10 - 98	32 - 320	345	x		48	32	8, 11, 28	15, 29
11 - 111	37 - 366	345	x		48	28	8, 11, 28	15, 29
13 - 127	42 - 415	672	x	x	28	28		15
14 - 145	47 - 475	672	x		32	28		15
19 - 190	62 - 623	672	x		48	32		15
22 - 217	71 - 712	672	x		48	28		15

Variable Speed								
2700 Belt		RPM From Gearmotor	Mount Package		Pulley Kit		Gearmotor Chart	
m/min	Ft/min		Top & Bottom	Side	Drive Pulley	Driven Pulley	Standard Load	Heavy Load
<b>CE</b> Gearmotor RPM at 50Hz.								
0.6 - 5.5	2 - 18	29	x		28	28	9	
0.6 - 6.2	2 - 20	29	x		32	28	9	
0.8 - 8.2	3 - 27	29	x		48	32	9	
0.8 - 8.3	3 - 27	44	x		28	28	9	
0.9 - 9.4	3 - 31	29	x		48	28	9	
1 - 9.5	3 - 31	44	x		32	28	9	
1 - 12	4 - 41	44	x		48	32	9	
1 - 14	5 - 47	44	x		48	28	9	
2 - 17	6 - 55	88	x		28	28	9	
2 - 19	6 - 62	88	x		32	28	9	
3 - 25	8 - 82	88	x		48	32	9	
3 - 28	9 - 93	88	x		48	28	9	
3 - 33	11 - 109	176	x		28	28	9	
4 - 38	12 - 124	176	x		32	28	9	
5 - 50	16 - 163	176	x		48	32	9	
6 - 57	19 - 186	176	x		48	28	9	
7 - 67	22 - 218	353	x		28	28	9	
8 - 76	25 - 249	353	x		32	28	9	
10 - 100	33 - 327	353	x		48	32	9	
11 - 114	37 - 374	353	x		48	28	9	

**Note:** Nose Bar transfers operate at maximum 23.5 m/min (77 ft/min) belt speed  
**Red** = Parallel Shaft, **Blue** = 90°

Other speeds available. See [www.dorner.com](http://www.dorner.com) and run the DTools program for a full list of belt speeds.

Refer to the Gearmotor Selection Steps on page 55 for instructions on using Belt Speed Charts

## 2200 Series Belted & Modular Belt Center Drive Mounting Package

2 2 M 2 P S 06 A - 3 2 3 2

- Drive / Driven Pulley Combination (Type 1 & 2 only)
- "-" = Belted, C = Modular Belt
- Gearmotor Mounting Position: A or D
- Conveyor Width Reference
- Gearmotor Type: S, H or W
- Gearmotor Output Shaft: P = Parallel Shaft or E = eDrive®
- Mount Style: 1 = Type 1, Vertical Mount  
2 = Type 2, Horizontal Mount S = Side
- Documentation Language: M = US, U = Europe

## 2200 Belted and Precision Move Mid Drive Mounting Package

2 2 M 6 P E S A - 2 8 2 8

- Pulley Kit (Drive/Driven) (Bottom only)
- Position: A or D
- Load Type: S = Standard  
H = Heavy K = Standard VFD
- Shaft Type: E = eDrive®  
P = Parallel W = SEW
- Position: B = Bottom S = Side
- Documentation Language: M = US, U = Europe

## 2700 Series Drive Mount Packages

2 L M B P S A - 3 2 3 2

- Drive / Driven Pulley Combination pulley options see note
- Controls/Flow/Drive Shaft Position: A, B, C or D A or D only for MID drive
- Gearmotor Type: S = Standard Load, H = Heavy Load
- Gearmotor Output Shaft: P = Parallel, E = eDrive 90, W = Sew 90
- Mount Style: B = Bottom Mount, T = Top Mount, S = Side Mount, N = MID drive Side Mount, M = MID drive Bottom Mount
- Documentation Language: M = US, U = Europe
- Prefix: 2L = End drive mount packages for 2700 Product

## Light Load, Fixed Speed

Chart 1		Parallel Shaft									
<ul style="list-style-type: none"> <li>• Sealed gearmotor</li> <li>• Totally enclosed, non-ventilated</li> <li>• Includes switch, cord and overload protection on 1 Phase unit</li> <li>• 115V, 1 Phase</li> <li>• 230V, 3 Phase</li> <li>• 60 Hz</li> </ul>										<p>Regulatory Approvals</p>	
Part Number	RPM	Gearmotor Type	Hp	kW	1 Phase			3 Phase			Starter Chart
					FLA	in.-lbs.	Nm	FLA	in.-lbs.	Nm	
62M036PL4(vp)F(N)	42	L	0.03	0.025	0.46	26	2.9	0.22	37	4.2	H
62M015PL4(vp)F(N)	100	L	0.03	0.025	0.46	12	1.4	0.22	16.8	1.9	H

(vp) = Voltage and Phase 11 = 115V, 1 phase 23 = 230V, 3 phase (n) = Reversing capability **N** = No reversing switch **R** = With reversing switch

## Light Load, Variable Speed

Chart 18		Parallel Shaft VFD Rated									
<ul style="list-style-type: none"> <li>• VFD Variable Speed</li> <li>• 230V, 3 Phase, 10 to 60 Hz</li> <li>• Totally enclosed, non-ventilated</li> <li>• Order controller separately, see page 65-67</li> </ul>										<p>Regulatory Approvals</p>	
Part Number	MAX RPM	MIN RPM	Gearmotor Type	Hp	kW	FLA	in.-lbs.	Nm	Vari - Speed Control Chart		
62M036PL423EN	42	7	L	0.03	0.025	0.22	37	4.2	E		
62M015PL423EN	100	17	L	0.03	0.025	0.22	16.8	1.9	E		

Chart 25		Parallel Shaft Brushless DC									
<ul style="list-style-type: none"> <li>• Closed loop brushless DC with hall effect feedback</li> <li>• Sealed gearbox</li> <li>• IP65 totally enclosed non-ventilated motor</li> <li>• 100 to 3000 rpm motor</li> <li>• Includes motor cord with quick disconnect</li> <li>• Order controller separately, see page 65-67</li> </ul>										<p>Regulatory Approvals</p>	
Part Number	MAX RPM	MIN RPM	Gearmotor Type	Hp	kW	FLA	in.-lbs.	Nm	Vari-Speed Control Chart		
62M050PLBDDENB	60	2	A	0.083	0.06	see control	70	7.7	F		
62M020PLBDDENB	150	5	A	0.083	0.06	see control	25	2.8	F		
62M015PLBDDENB	200	7	A	0.083	0.06	see control	18	2	F		

FLA = Full Load Amperes

Some motors and gear reducers may normally operate hot to the touch. Consult factory for specific operating temperatures. Dim = mm (in)

## Standard Load, Fixed Speed

Chart 4		90°									
<ul style="list-style-type: none"> <li>Sealed gearmotor</li> <li>NEMA 42 CZ C Face</li> <li>Totally enclosed, fan cooled</li> <li>115V 1 phase includes switch, cord and overload protection</li> <li>208-230/460 Volts, 3 phase wiring by others</li> <li>60 Hz</li> <li>Order 3 phase starter separately, see page 68</li> </ul>										Regulatory Approvals 	
Part Number	RPM	Gearmotor Type	1 Phase			3 Phase			in.-lbs.	Nm	3 Phase Starter Chart
			Hp	kW	FLA	Hp	kW	FLA			
62M060ES4(vp)FN	29	S	0.25	0.19	3.1	0.38	0.29	1.9 / 0.95	134/134	15.1/15.1	M
62M040ES4(vp)FN	43	S	0.25	0.19	3.1	0.38	0.29	1.9 / 0.95	160/160	18.1/18.1	M
62M020ES4(vp)FN	86	S	0.25	0.19	3.1	0.38	0.29	1.9 / 0.95	133/151	15/17.1	M
62M010ES4(vp)FN	173	S	0.25	0.19	3.1	0.38	0.29	1.9 / 0.95	75/114	8.5/12.9	M
62M005ES4(vp)FN	345	S	0.25	0.19	3.1	0.38	0.29	1.9 / 0.95	39/60	4.4/6.8	M

(vp) = Voltage and Phase      11 = 115V, 1 phase    23 = 208 - 230 / 460V, 3 phase

Chart 5		Parallel Shaft										
<ul style="list-style-type: none"> <li>Sealed gearmotor</li> <li>Totally enclosed, fan cooled</li> <li>115V 1 phase includes switch, cord and overload protection</li> <li>230/460 Volts, 3 phase wiring by others</li> <li>60 Hz</li> <li>Order 3 phase starter separately, see page 68</li> </ul>										Regulatory Approvals 		
Part Number	RPM	Gearmotor Type	1 Phase				3 Phase				Nm	3 Phase Starter Chart
			Hp	kW	FLA	in.-lbs.	Hp	kW	FLA	in.-lbs.		
62M180PS4(vp)F(n)	10	S	0.17	0.13	1.9	341	0.17	0.13	1.0 / 0.5	341	38.5	L
62M060PS4(vp)F(n)	29	S	0.17	0.13	1.9	270	0.17	0.13	1.0 / 0.5	270	30.5	L
62M030PS4(vp)F(n)	58	S	0.17	0.13	1.9	135	0.38	0.28	1.9 / 0.95	250	15.3	M
62M020PS4(vp)F(n)	86	S	0.17	0.13	1.9	90	0.38	0.28	1.9 / 0.95	167	10.2	M
62M010PS4(vp)F(n)	173	S	0.17	0.13	1.9	45	0.38	0.28	1.9 / 0.95	115	5.1	M
62M005PS4(vp)F(n)	345	S	0.17	0.13	1.9	25	0.38	0.28	1.9 / 0.95	58	2.8	M

(vp) = Voltage and Phase    11 = 115V, 1 phase    23 = 230/460V, 3 phase  
 (n) = Reversing Capability    N = No reversing switch    R = With reversing switch (115V, 1 phase only)

## Standard Load, Fixed Speed (continued)

**Chart 6**    **CE 90°**

- Sealed gearmotor
- IEC 63 B5 C Face
- IP 55 protection rating
- Totally enclosed, fan cooled
- Non-reversing
- 50 Hz
- Order starter separately, see page 68

### eDrive®

Part Number	RPM	Gearmotor Type	1Ph		3 Ph		Nm	Starter Chart
			kW	FLA	kW	FLA		
62Z060ES4(vp)FN	23	S	0.18	1.6	0.25	1.56/0.9	36/36	I
62Z040ES4(vp)FN	35	S	0.18	1.6	0.25	1.56/0.9	26.9/35.5	I
62Z020ES4(vp)FN	70	S	0.18	1.6	0.25	1.56/0.9	16/21.2	I
62Z010ES4(vp)FN	140	S	0.18	1.6	0.25	1.56/0.9	8.7/11.4	I
62Z005ES4(vp)FN	280	S	0.18	1.6	0.25	1.56/0.9	4.5/5.9	I

(vp) = Voltage and Phase    21 = 230V, 1 phase  
 23 = 230V, 3 phase    43 = 400V, 3 phase

**CE Note:** When buying a gearmotor only without the starter, the customer must supply their own on/off switch and motor overload protection to comply with the CE Safety Directive.

**Chart 19**    **90° SEW**

- SEW WA20 Gearmotor
- Bottom, Center and Side mount packages available
- 230 / 460 V 3 Phase
- VFD Compatible with constant torque from 10 to 60 Hz
- Sealed gear head, totally enclosed fan cooled motor

Part Number	RPM	Gearmotor Output Shaft	Gearmotor Type	Hp	kW	FLA	in-lbs	Nm	3 Phase Starter Chart
22M039WS423EN	46	W	S	0.25	0.19	0.89 / 0.44	203	22.9	L
22M017WS423EN	109	W	S	0.33	0.25	1.24 / 0.62	159	18.0	L
22M008WS423EN	219	W	S	0.50	0.37	1.84 / 0.92	132	14.9	M

FLA = Full Load Amperes

Some motors and gear reducers may normally operate hot to the touch. Consult factory for specific operating temperatures. Dim = mm (in)

## Standard Load, Variable Speed

**Chart 28** 90° VFD Rated

- Variable frequency drive, 10 to 60 Hz
- Sealed gearbox
- Nema 42CZ C face
- Totally enclosed, fan cooled
- 230/460Volts, 3 Phase
- Order controller separately
- UL and CSA Listed, RoHS compliant

**Regulatory Approvals**  
UL  
SP

Part Number	MAX RPM	MIN RPM	Gearmotor Type	Hp	kW	FLA	in-lbs	Nm	Vari-Speed Control Chart
62M060ES423EN	29	5	S	0.38	0.28	1.9 / 0.95	134	15.1	D and E
62M040ES423EN	43	7	S	0.38	0.28	1.9 / 0.95	160	18.1	D and E
62M020ES423EN	86	14	S	0.38	0.28	1.9 / 0.95	151	17.1	D and E
62M010ES423EN	173	29	S	0.38	0.28	1.9 / 0.95	114	12.9	D and E
62M005ES423EN	345	58	S	0.38	0.28	1.9 / 0.95	60	6.8	D and E

**Chart 8** 90° VFD Rated

**eDrive®**

- Variable frequency drive, 6 - 60 Hz
- Sealed gearmotor
- NEMA 56C C Face
- Totally enclosed, fan cooled
- 208-230/460 Volts, 3 phase
- Order controller separately, see page 65-67

**Regulatory Approvals**  
RU  
SP

Part Number	MAX RPM	MIN RPM	Gearmotor Type	Hp	kW	FLA	in.-lbs.	Nm*	Vari-Speed Control Chart
32M060EL423EN	29	3	K	0.5**	0.37	1.76-1.71 / 1.14	319	36	D and E
32M040EL423EN	43	4	K	0.5**	0.37	1.76-1.71 / 1.14	238	26.9	D and E
32M020EL423EN	86	9	K	0.5**	0.37	1.76-1.71 / 1.14	142	16.0	D and E
32M010EL423EN	173	17	K	0.5**	0.37	1.76-1.71 / 1.14	77	8.7	D and E
32M005EL423EN	345	35	K	0.5**	0.37	1.76-1.71 / 1.14	40	4.5	D and E

\* = At 60 Hz \*\* = Motor de-rated to 0.25 Hp for full torque throughout speed range.

**Chart 9** CE 90°

**eDrive®**

- Variable frequency drive, 25-63 Hz
- Sealed gearmotor
- IEC 63 B5 C Face
- IP 55 protection rating
- Totally enclosed, fan cooled
- 230/400 Volts, 3 phase
- Order controller separately, see page 65-67

Part Number	MAX RPM	MIN RPM	Gearmotor Type	3 Ph kW	3 Ph FLA	Nm*	Vari-Speed Control Chart
62Z060ES423EN	29	12	S	0.25	1.56 / 0.9	36	B
62Z040ES423EN	44	18	S	0.25	1.56 / 0.9	35.5	B
62Z020ES423EN	88	35	S	0.25	1.56 / 0.9	21.2	B
62Z010ES423EN	176	70	S	0.25	1.56 / 0.9	11.4	B
62Z005ES423EN	353	140	S	0.25	1.56 / 0.9	5.9	B

\* = At 50 Hz

**CE Note:** When buying a gearmotor only without the starter, the customer must supply their own on/off switch and motor overload protection to comply with the CE Safety Directive.

**FLA = Full Load Amperes**

Some motors and gear reducers may normally operate hot to the touch. Consult factory for specific operating temperatures. Dim = mm (in)

Standard Load, Variable Speed (continued)

Chart 11		Parallel Shaft VFD Rated								Regulatory Approvals UL CE
<ul style="list-style-type: none"> <li>• Variable frequency drive, 10 to 60 Hz</li> <li>• Sealed gearmotor</li> <li>• Totally enclosed, fan cooled</li> <li>• 230/460 Volts / 3 Phase, VFD duty</li> <li>• Order controller separately, see page 65-67</li> </ul>										
Part Number	MAX RPM	MIN RPM	Gearmotor Type	Hp	kW	FLA	in.-lbs.	Nm	Vari - Speed Control Chart	
62M180PS423EN	10	2	S	0.17	0.13	1.0 / 0.5	341	38.5	D and E	
62M060PS423EN	29	5	S	0.17	0.13	1.0 / 0.5	270	30.5	D and E	
62M030PS423EN	58	10	S	0.38	0.28	1.9 / 0.95	250	28.3	D and E	
62M020PS423EN	86	14	S	0.38	0.28	1.9 / 0.95	167	18.9	D and E	
62M010PS423EN	173	29	S	0.38	0.28	1.9 / 0.95	115	13.0	D and E	
62M005PS423EN	345	58	S	0.38	0.28	1.9 / 0.95	58	6.5	D and E	

Chart 26		Parallel Shaft Brushless DC								Regulatory Approvals UL CE RoHS
<ul style="list-style-type: none"> <li>• Closed loop brushless DC with hall effect feedback</li> <li>• Sealed gearbox</li> <li>• IP65 totally enclosed non-ventilated motor</li> <li>• 100 to 3000 rpm motor</li> <li>• Includes motor cord with quick disconnect</li> <li>• Order controller separately, see page 65-67</li> </ul>										
Part Number	MAX RPM	MIN RPM	Gearmotor Type	Hp	kW	FLA	in.-lbs.	Nm	Vari-Speed Control Chart	
62M050PSBDDENB	60	2	B	0.25	0.2	see control	240	27.1	F	
62M020PSBDDENB	150	5	B	0.25	0.2	see control	101	11.4	F	
62M010PSBDDENB	300	10	B	0.25	0.2	see control	50	5.6	F	

Chart 20		90° SEW								Regulatory Approvals UL CE
<ul style="list-style-type: none"> <li>• SEW WA20 Gearmotor</li> <li>• Bottom, Center and Side mount packages available</li> <li>• 230 / 460 V 3 Phase</li> <li>• VFD Compatible with constant torque from 10 to 60 Hz</li> <li>• Sealed gear head, totally enclosed fan cooled motor</li> </ul>										
Part Number	MAX RPM	MIN RPM	Gearmotor Output Shaft	Gearmotor Type	Hp	kW	FLA	in.-lbs.	Nm	Vari - Speed Control Chart
22M039WS423EN	46	8	W	S	0.25	0.19	0.89 / 0.44	203	22.9	D and E
22M017WS423EN	109	18	W	S	0.33	0.25	1.24 / 0.62	159	18.0	D and E
22M008WS423EN	219	37	W	S	0.50	0.37	1.84 / 0.92	132	14.9	D and E

FLA = Full Load Amperes

Some motors and gear reducers may normally operate hot to the touch. Consult factory for specific operating temperatures. Dim = mm (in)

## Heavy Load, Fixed Speed

Chart 12		90°									
<ul style="list-style-type: none"> <li>Sealed gearmotor</li> <li>NEMA 56 C Face</li> <li>Totally enclosed, fan cooled</li> <li>115V 1 phase includes switch, cord and overload protection</li> <li>208-230/460 Volts, 3 phase wiring by others</li> <li>60 Hz</li> <li>Order 3 phase starter separately, see page 68</li> </ul>										<p>Regulatory Approvals</p>	
Part Number	RPM	Gearmotor Type	1 Phase			3 Phase			in.-lbs.	Nm	3 Phase Starter Chart
			Hp	kW	FLA	Hp	kW	FLA			
32M060ES4(vp)FN	29	H	0.5	0.37	5.7	0.5	0.37	1.76-1.71 / 1.14	319	36	M
32M040ES4(vp)FN	43	H	0.5	0.37	5.7	0.5	0.37	1.76-1.71 / 1.14	378	42.7	M
32M020ES4(vp)FN	86	H	0.5	0.37	5.7	0.5	0.37	1.76-1.71 / 1.14	285	32.2	M
32M010ES4(vp)FN	173	H	0.5	0.37	5.7	0.5	0.37	1.76-1.71 / 1.14	153	17.3	M
32M005ES4(vp)FN	345	H	0.5	0.37	5.7	0.5	0.37	1.76-1.71 / 1.14	80	9	M
32M005ES223FN	672	H	-	-	-	0.75	0.55	2.15 / 1.37	33	3.7	M

(vp) = Voltage and Phase

11 = 115V, 1 phase    23 = 208 - 230 / 460V, 3 phase

## Heavy Load, Variable Speed

Chart 15		90° VFD Rated									
<ul style="list-style-type: none"> <li>Variable frequency drive, 6 - 60 Hz</li> <li>Sealed gearmotor</li> <li>NEMA 56 C Face</li> <li>Totally enclosed, fan cooled</li> <li>230/460 Volts, 3 Phase</li> <li>Order controller separately, see page 65-67</li> </ul>										<p>Regulatory Approvals</p>	
Part Number	MAX RPM	MIN RPM	Gearmotor Type	3 Ph Hp	3 Ph kW	3 Ph FLA	in.-lbs.*	Nm*			
32M060ES423EN	29	3	H	0.75**	0.55	2.6 / 1.3	319	36			
32M040ES423EN	43	4	H	0.75**	0.55	2.6 / 1.3	378	42.7			
32M020ES423EN	86	9	H	0.75**	0.55	2.6 / 1.3	285	32.2			
32M010ES423EN	173	17	H	0.75**	0.55	2.6 / 1.3	153	17.3			
32M005ES423EN	345	35	H	0.75**	0.55	2.6 / 1.3	80	9			
32M005ES223EN	672	67	H	0.75**	0.55	2.15 / 1.37	33	3.7			

\* = At 60 Hz    \*\* = Motor de-rated to 0.5 Hp for full torque throughout speed range

Chart 29		90° VFD Rated									
<ul style="list-style-type: none"> <li>Variable frequency drive, 6 - 60 Hz</li> <li>Sealed gearmotor</li> <li>NEMA 56 C Face</li> <li>Totally enclosed, fan cooled</li> <li>575 Volts, 3 Phase</li> </ul>										<p>Regulatory Approvals</p>	
Part Number	MAX RPM	MIN RPM	Gearmotor Type	3 Ph Hp	3 Ph kW	3 Ph FLA	in.-lbs.*	Nm*	Vari Speed Control Chart		
32M060ES453EN	29	3	H	0.5	0.37	0.76	319		Customer Supplied		
32M040ES453EN	43	4	H	0.5	0.37	0.76	378		Customer Supplied		
32M020ES453EN	86	9	H	0.5	0.37	0.76	285		Customer Supplied		
32M010ES453EN	173	17	H	0.5	0.37	0.76	153		Customer Supplied		
32M005ES453EN	345	34	H	0.5	0.37	0.76	80		Customer Supplied		

\* = At 60 Hz

FLA = Full Load Amperes

Some motors and gear reducers may normally operate hot to the touch. Consult factory for specific operating temperatures. Dim = mm (in)

Control Product Family



**2700 iDrive2 Controls**

(see page 24)

Brushless DC Controls, 24VDC with preset speeds programed ready to use package



**Basic VFD Control**

(see page 81)

Simple on/off, direction, and speed control right at the side of the conveyor



**Full Feature VFD Control**

(see page 80)

All the features of a Basic VFD with options to control remotely from a Dorner accessory, discrete I/O, or using a variety of industrial network protocols



**Full Feature VFD with Accessory**

(see page 80, 85-86)

Full feature control with M12 Accessory port for a variety of applications



**Brushless DC Control**

(see page 81)

Provides a compact alternative to other solutions while providing indexing capabilities of 60 indexes per minute with accuracy less than 3.2 mm (1/16 in)



**Servo Motor Control**

(see page 83-84)

Provides programmable move profiles and indexing control up to 100 per minute at accuracies of 1 mm (0.040 in)

## Variable Speed Controllers

**Chart B** VFD Controller, Full CE Compliance

- VFD control
- IP 65 enclosure
- EMC filter
- Variable speed
- Mounting hardware
- Line cord and motor cord
- Motor cord only on 460V

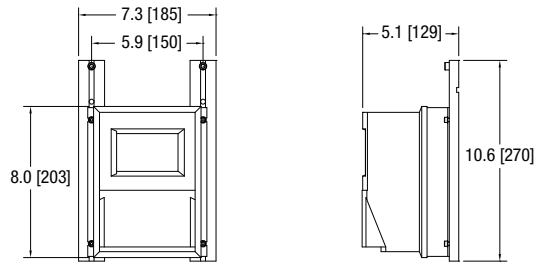

Regulatory Approvals

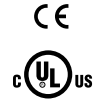

Part Number	Input Volts	Input Phase	Input Hz	Output Volts	Output Phase	Max Kw*	Max Amps	Reversing
62UV2121(O)	230	1	50	230	3	0.75	4.2	Yes
62UV4341(O)	400	3	50	400	3	0.75	2.1	Yes
62UV2127(O)	230	1	50	230	3	1.50	6.8	Yes
62UV4347(O)	400	3	50	400	3	1.50	3.4	Yes

(O) = Optional M12 Accessory Port No Option = No Accessory Port E = M12 Port wired for End Stop Photo Eye Application I = M12 port wired for Index Photo Eye Application

Note: E or I options will work with Dorner Control Stop or Jog Button Accessories

**Chart D** Full Feature VFD Controller

- Full feature VFD control
- NEMA 4 enclosure
- Digital display
- Keypad with Start/Stop, Forward/Reverse and speed variations
- Includes cord to motor
- Power to controller by others
- 62MV1122 includes line cord to controller
- Mounting hardware

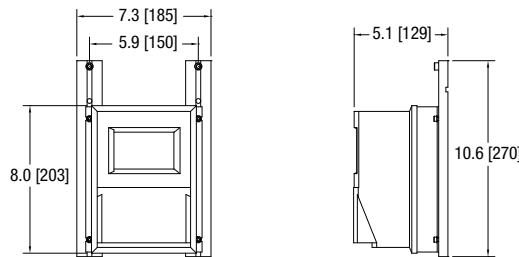

Regulatory Approvals

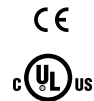

Part Number	Input Volts	Input Phase	Input Hz	Output Volts	Output Phase	Max Hp	Output Amps*	Reversing
32MV1122(O)	115	1	60	230	3	0.5	2.2	Yes
32MV2122(O)	230	1	60	230	3	0.5	2.2	Yes
32MV1121(O)	115	1	60	230	3	1.0	4.0	Yes
32MV2121(O)	230	1	60	230	3	1.0	4.0	Yes
32MV2127(O)	230	1	60	230	3	2.0	6.8	Yes
32MV2322(O)	230	3	60	230	3	0.5	2.2	Yes
32MV2327(O)	230	3	60	230	3	2.0	6.8	Yes
32MV4341(O)	460	3	60	460	3	1.0	2.0	Yes
32MV4347(O)	460	3	60	460	3	2.0	3.4	Yes

In order for this drive to meet full CE requirements for European application a separate CE approve RFI filter must be installed. Product shown in chart B above have this filter pre-installed and are recommended for use in the European Union.

(O) = Optional M12 Accessory Port No Option = No Accessory Port E = M12 Port wired for End Stop Photo Eye Application

I = M12 port wired for Index Photo Eye Application

Note: E or I options will work with Dorner Control Stop or Jog Button Accessories

\* = See FLA from motor charts Dim = mm (in)

## Variable Speed Controllers (continued)

Chart E		Basic VFD Controller						
<ul style="list-style-type: none"> <li>• Variable Speed Drive</li> <li>• On/off buttons and knob for speed on keypad</li> <li>• Direction setting via parameter change</li> <li>• Includes mounting bracket that can mount drive to vertical or horizontal T-slot</li> <li>• Includes 10ft input power cord with three prong standard 120V outlet plug</li> <li>• Includes 10ft motor output cord for 3 phase motor connection with flying leads</li> <li>• IP 20 rating with electrical finger safe connections</li> <li>• Pre-programmed to match motor parameters and locked parameter settings for ease of uses</li> <li>• cULus and CE compliant</li> </ul>							<p>Regulatory Approvals</p> <p>CE</p> <p>RoHS</p> <p>cULus</p>	
Part Number	Input Volts	Input Phase	Input Hz	Output Volts	Output Phase	Max Hp	Max Amps	Reversing
22MV1126T	115	1	60	230	3	0.125-0.5	2.6	Yes*

\*Reversing is controlled by parameter change

Chart F		Brushless DC Controller						
<ul style="list-style-type: none"> <li>• Closed loop brushless DC with hall effect feedback</li> <li>• Nema 1 plastic enclosure</li> <li>• Digital keypad and display</li> <li>• Programmable speed, acceleration and deceleration</li> <li>• Remote on / off and speed capable with wire access hole in enclosure provided</li> <li>• Includes motor cord with quick disconnect and power cord (single phase only)</li> <li>• Includes mounting brackets and hardware</li> </ul>							<p>Regulatory Approvals</p> <p>RU</p> <p>CE</p>	
Part Number	Input Volts	Input Phase	Input Hz	Max Input Amps	Output	Max Watts	Reversing	
63MBD11B60B	115	1	60	4.5	BDC	60	Yes	
63MBD23B60B	230	3	60	1.5	BDC	60	Yes	
63MBD11B200B	115	1	60	8.8	BDC	200	Yes	
63MBD23B200B	230	3	60	3.4	BDC	200	Yes	

\* = See FLA from motor charts Dim = mm (in)

## Manual Motor Starters

Manual motor starts are manual electronic disconnects that provide motor overload protection and are required by the National Electric Code (NEC) for safe motor operation.

- IP 55 Enclosure
- Push button Start / Stop
- Includes mounting hardware

Regulatory Approvals

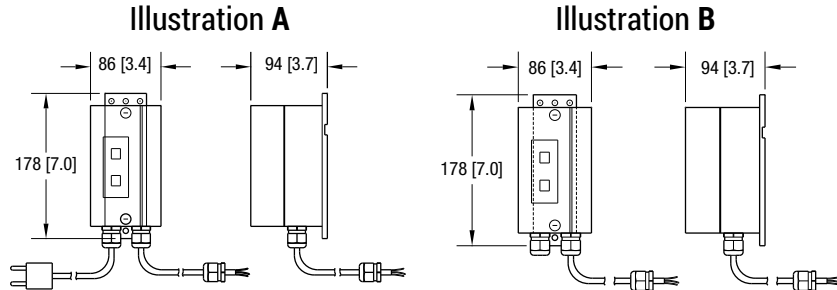

Chart H		CE		
<ul style="list-style-type: none"> <li>• 230V, 1 phase includes cord, plug &amp; starter</li> <li>• 230/400 Volts, 3 phase wiring to starter by others</li> <li>• Wiring between motor and starter provided when ordered together</li> <li>• 50 Hz</li> </ul>				
Part Number	In Volts	In Phase	Amp Range	Illustration
62UM21H	230	1	0.25 - 0.4	A
62UM23H	230	3	0.16 - 0.25	B
62UM43H	400	3	0.1 - 0.16	B

Chart I		230/400V 50Hz to 2.5 amp		
<ul style="list-style-type: none"> <li>• 230 Volts, 1 phase includes cord, plug and starter</li> <li>• 230/400 Volts, 3 phase wiring to starter by others</li> <li>• Wiring between motor and starter provided when ordered together</li> <li>• 50 Hz</li> </ul>				
Part Number	In Volts	In Phase	Amp Range	Illustration
62UM21T	230	1	1.6 - 2.5	A
62UM23T	230	3	1.0 - 1.6	B
62UM43T	400	3	0.63 - 1.0	B

Chart L		230/460V 60 Hz to 1.6 amp		
<ul style="list-style-type: none"> <li>• 230/460 Volts, 3 phase wiring to starter by others</li> <li>• Wiring between motor and starter provided when ordered together</li> <li>• 60 Hz</li> </ul>				
Part Number	In Volts	In Phase	Amp Range	Illustration
62MM23L	230	3	1.0 - 1.6	B
62MM43L	460	3	0.4 - .63	B

Chart M		230/460V 60Hz to 2.5 amp		
<ul style="list-style-type: none"> <li>• 230/460 Volts, 3 phase wiring to starter by others</li> <li>• Wiring between motor and starter provided when ordered together</li> <li>• 60 Hz</li> </ul>				
Part Number	In Volts	In Phase	Amp Range	Illustration
62MM23M	208 -	3	1.6 - 2.5	B
62MM43M	230 460	3	1.0 - 1.6	B

**| CE Note:** When buying a gearmotor only without the starter, the customer must supply their own on/off switch and motor overload protection to comply with NEC and CE safety directive.

Dim = mm (in)

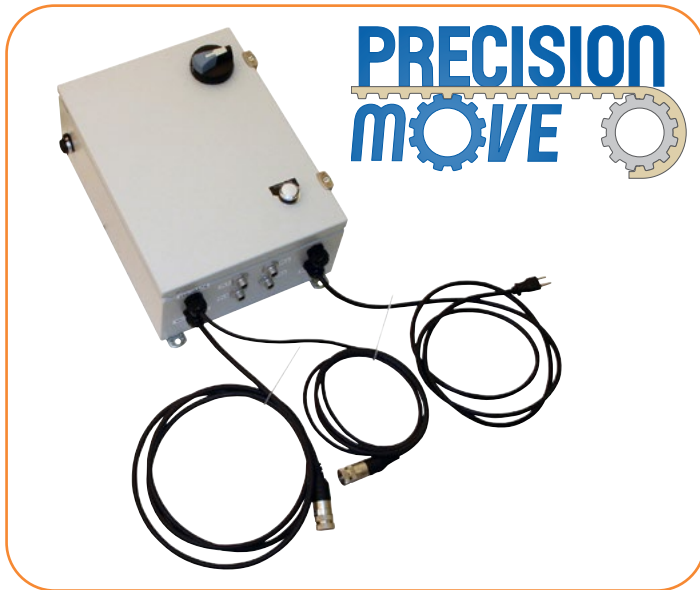

**Specifications**

- Quick disconnect cables compatible with Dorner Servo Gearmotors
- Graphical user interface and icons make programming easy
- Spreadsheet-like position programming
- Real time performance feedback software
- Click of a button auto-tuning and wizard tuning per application
- Multiple homing options
- Kollmorgen AKD Series Control
- 1100 watts capacity
- (2) Input voltage options:
  - 115 Volt Single Phase input
  - 230 Volt Single Phase input
- UL listed, CE marked and RoHS compliant drive and components
- UL Labeled Controller Package
- Housed in a Nema 12 enclosure
- Includes high voltage fusing and low voltage power supply
- Quick disconnect motor cabling
- Quick disconnect sensor locations

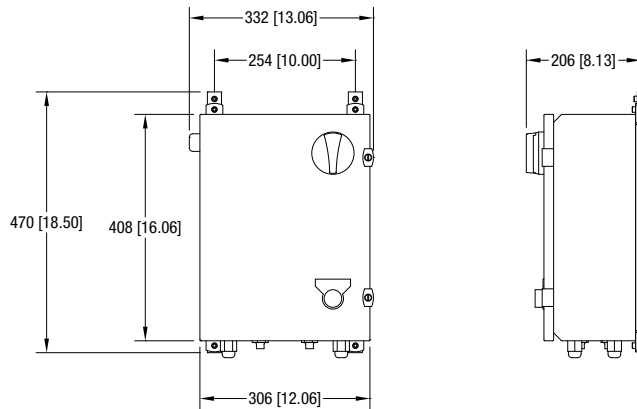

**Compatible Servo Motors Available**



See pages 20 - 25 for more information.

**Gearmotor Compatibility**

Part Number	Controller Voltage	Max Belt Speed (Ft/min)		Min Belt Speed (Ft/min)	Torque (in-lb)	RPM
		Bottom Mount	Flush Mount			
22M004PR2B1KW	115V input	166	253	10	79	325
	230V input	276	420	10	79	625

Model	Part Number	Input Volts	Input Phase	Input Hz	Cont. Amps	Peak Amps	Cont. Watts
115V Stand Alone*	75M-S1-11-3	115	1	60	3	9	1100
115V External Control	75M-S2-11-3	115	1	60	3	9	1100
230V Stand Alone*	75M-S1-21-3	230	1	60	3	9	1100
230V External Control	75M-S2-21-3	230	1	60	3	9	1100

\* Note: For Stand Alone Control Applications, Enable / Index Kit (75M-EN-1) is recommended. See page 81 for details.

Due to the wide variety of conveyor and stand options along with possible configurations, stability of the final setup is the responsibility of the end user.

Dim = mm (in)

For Accuracy and Repeatability Chart see page 120

# 2200/2700 SERIES PRECISION MOVE SERVO MOTOR INDEXERS

## (2) Servo Control Methods

### Stand Alone Control:

Servo Package is self-contained and the control signal is provided by a connected sensor or push button.

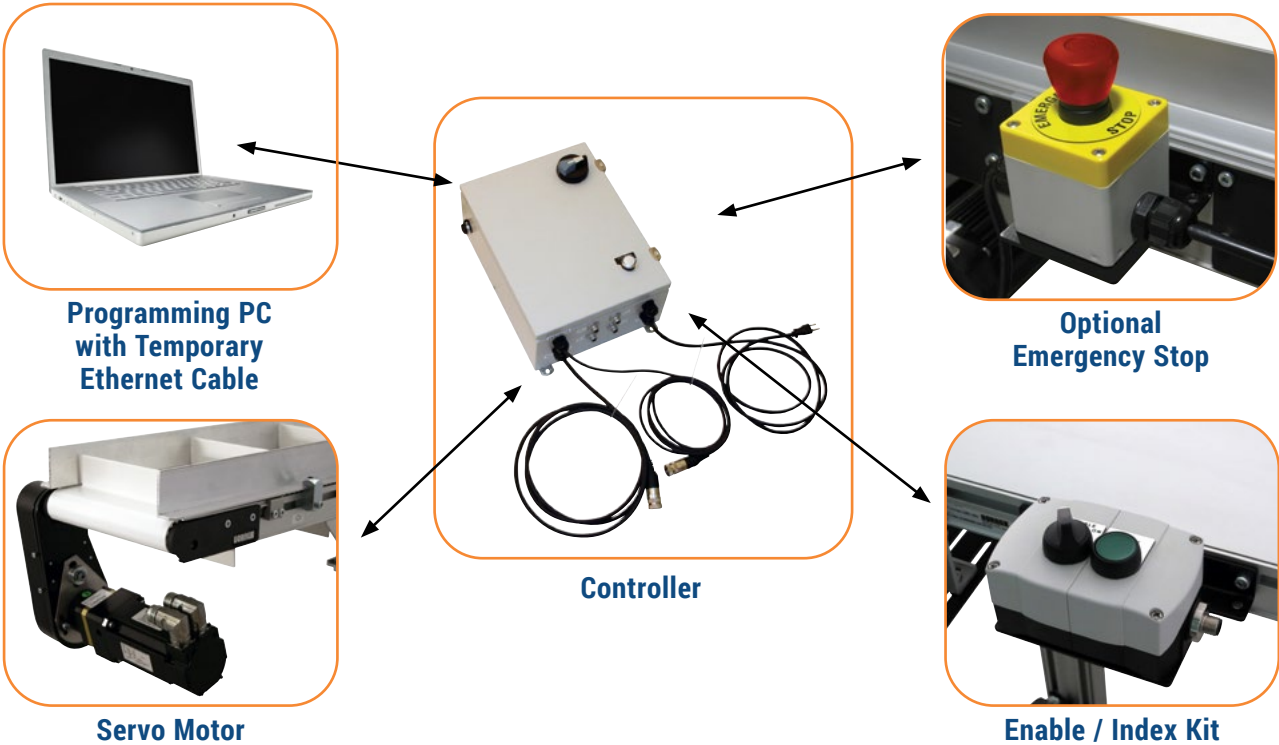

### External Control:

Servo control signal is controlled by an external source such as a PLC or PC.

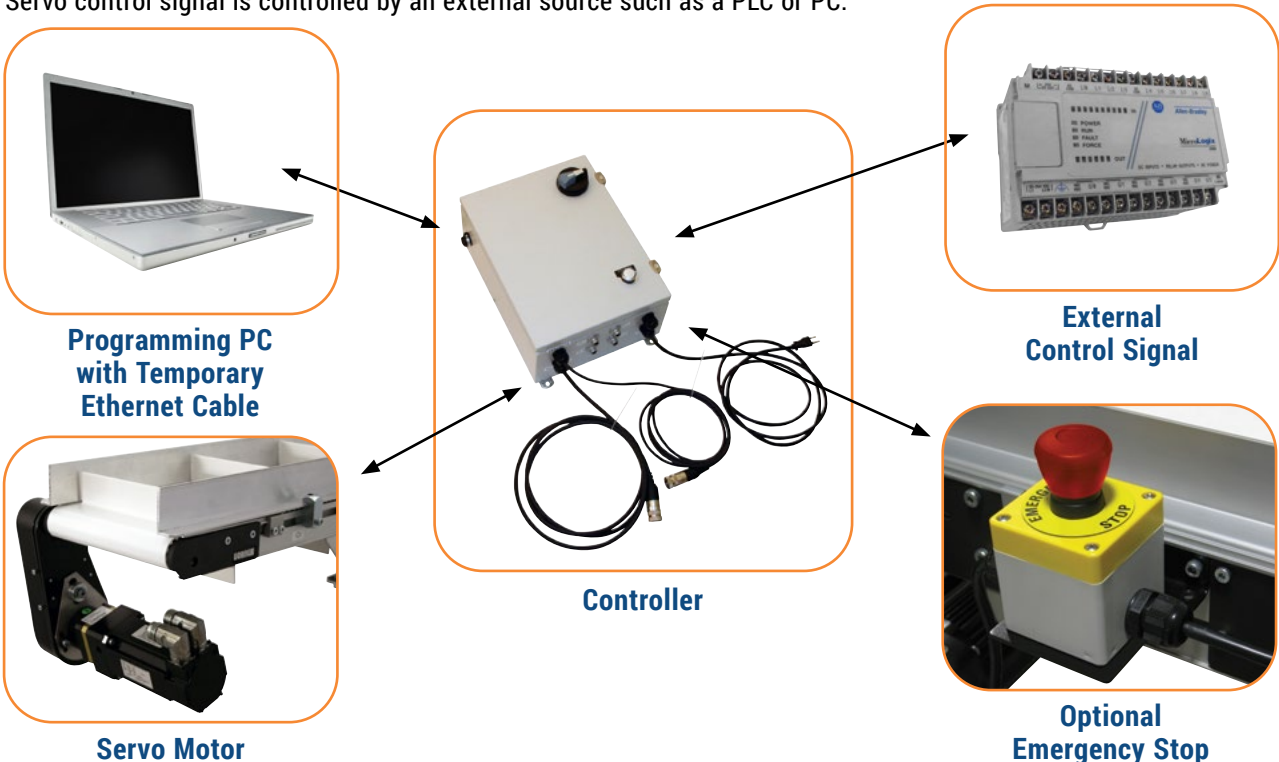

Stand Alone Servo Control – Enable / Index Kit



Specifications

- For use with stand alone servo motor controls
- Contains servo enable on/off and index initiate button
- Quick disconnect cable fittings
- Includes mounting bracket and hardware

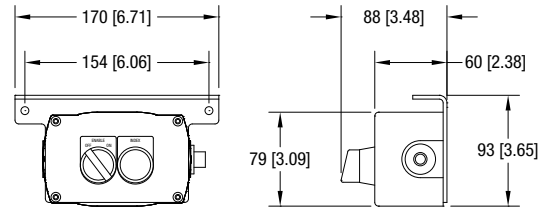

Part Number	75M-EN-1
-------------	----------

Servo Control – Emergency Stop Kit



Specifications

- For use with both stand alone and external control servos motor controls
- Plastic Nema 12 Enclosure
- Quick disconnect cable fittings
- Horizontal or vertical mount
- Includes mounting bracket and hardware

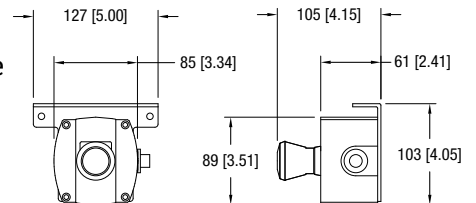

Part Number	Description
75M-ES-2	Non-Lighted E-Stop Kit

In-Line Cord Emergency Stop Kit



Specifications

- Push to stop/pull to start push button
- Plastic Nema 12 enclosure
- 115V single phase
- 1/2 hp (0.37 kW) and smaller motors
- Includes power and outlet cords
- Mounting for 2200/3200 and Support Stands
- Horizontal or vertical mount

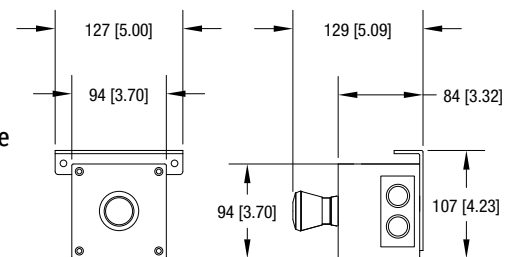

Part Number	75M-ES-1
-------------	----------

Photo Eye Kits



Specifications

- 24V DC Retro Reflective Sensor
- Quick disconnect plug
- Includes reflector and mounting
- Fully adjustable mount for 2200/3200 Series conveyors
- 50 mm (2 in) and 127 mm (5 in) adjustment height ranges

Part Number	Description
75M-PE-1	50 mm (2 in) Height Adjustment
75M-PE-2	127 mm (5 in) Height Adjustment
75M-PM-1	50 mm (2 in) Height Adjustment, Bracket Only, Retroreflective
75M-PM-2	127 mm (5 in) Height Adjustment, Bracket Only, Retroreflective
75M-PM-3	50 mm (2 in) Height Adjustment, Bracket Only, Through Beam
75M-PM-4	127 mm (5 in) Height Adjustment, Bracket Only, Through Beam
75M-PM-5	50 mm (2 in) Height Adjustment, Bracket Only, Convergence
75M-PM-6	127 mm (5 in) Height Adjustment, Bracket Only, Convergence

Not compatible with Brushless DC Controllers

Dim = mm (in)

## Jog Push Button Kit



### Specifications

- Momentary contact push button
- Plastic Nema 12 enclosure
- Quick disconnect receptacle
- Mounting for 2200/3200 and Support Stands
- Horizontal or vertical mount

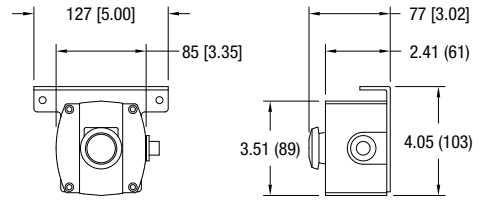

Part Number 75M-JG-1



Horizontal Mount

Not compatible with Brushless DC Controllers

## Control Stop Kit



### Specifications

- Push to stop/pull to start maintained push button
- Plastic Nema 12 enclosure
- Quick disconnect receptacle
- Mounting for 2200/3200 and Support Stands
- Horizontal or vertical mount

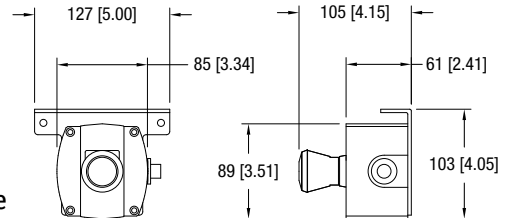

Part Number 75M-CS-1



Horizontal Mount

Not compatible with Brushless DC Controllers

## Linking Cable Kits (for VFD Indexers)



### Specifications

- Quick disconnect cable for all control devices
- 2 meter and 5 meter lengths
- Includes mounting hardware for T-slots

Part Number	Description
75M-LC-1	1.83 m (6 ft) cable
75M-LC-2	4.57 m (15 ft) cable

Dim = mm (in)

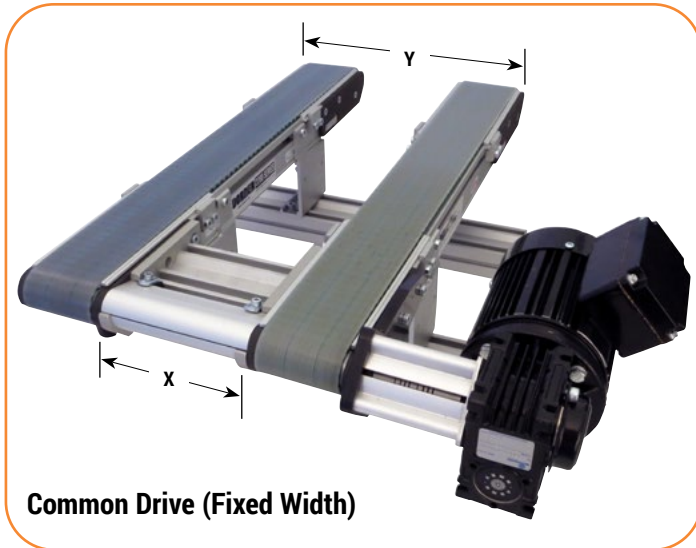

**Common Drive (Fixed Width)**

### Specifications

- Parts can be wider than conveyor
- Conveyors can be different widths & lengths
- Minimum width (x) = 69 mm (2.70 in)
- Maximum width (y) = 914 mm (36 in) belt to belt
- Maximum number of conveyors = 3
- Maximum total torque = 100 in-lbs
- Keyless coupling allows belt synchronization between conveyors
- Includes shafts, couplings and guards
- Order conveyor tie kits separately
- Requires stub output shafts between conveyors

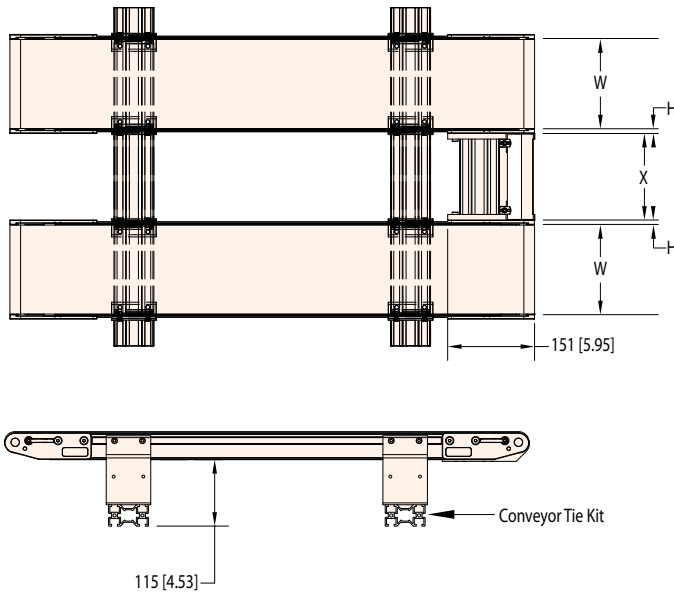

#### Headplate offset "H"

- Belted = 8.6 (.34)
- Precision Move = 8.6 (.34)
- Modular Belt = 13.2 (.52)

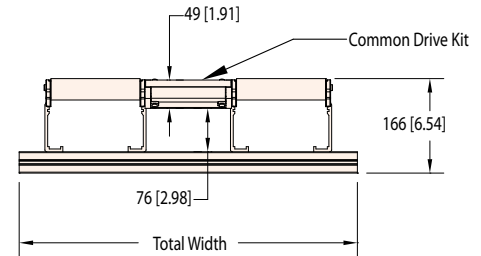

#### 2200 Series Common Drive Kit

22CDMK G G G G

00270 (68.9 mm [2.70 in]) to  
03600 (914 mm [36.00 in])

**Note:** One kit must be ordered for each pair of conveyors

#### Kit Includes:

- Shafts, couplings and guards
- Rigid tie plate for alignment
- Conveyor must be ordered with stubshaft on fixed end

#### 2200 Series Common Drive Table Mount Tie Kit

39MCT W W - Y

Number of Conveyors: 1 to 6  
Total Width: 02 to 48

#### Kit Includes:

- Conveyor mounting brackets
- Support extrusion

Dim = mm (in)

Due to the wide variety of drive set ups and applications, point of installation guarding is the responsibility of the end user.



## Specifications

- Loads up to 119 kg/m (80 lbs/ft)\*
- Conveyor widths: 152 mm (6 in), 305 mm (12 in), 457 mm (18 in) and 610 mm (24 in)
- Conveyor lengths: 610 mm (2 ft) to 3,658 mm (12 ft) in 152 mm (6 in) increments
- Single piece frame lengths to 12' long
- Rollers: 25 mm (1 in) diameter rollers on 31 mm (1.2 in), 61 mm (2.4 in) or 91 mm (3.6 in) centers
- Roller Material: Anodized aluminum tube with steel ball bearing
- Side T-slot fits Dorner drop in hardware
- T-slot fits standard M6 square nuts



### OPTIONAL: End Stop

(See page 86 for more details)

### Load Capacity

Length	Max. Load**	# of Support Stands
610 (2)	36 kg (80 lbs/ft)*	2
914 (3)	36 kg (80 lbs/ft)*	2
1,219 (4)	18 kg (40 lbs/ft)*	2
1,524 (5)	9 kg (20 lbs/ft)*	2
1,829 (6)	4.5 kg (10 lbs/ft)*	2
2,134 (7)	36 kg (80 lbs/ft)*	3
2,438 (8)	18 kg (40 lbs/ft)*	3
2,743 (9)	18 kg (40 lbs/ft)*	3
3,048 (10)	9 kg (20 lbs/ft)*	3
3,353 (11)	9 kg (20 lbs/ft)*	3
3,658 (12)	4.5 kg (10 lbs/ft)*	3

Dim = mm (ft)

\* Adding Supports increases capacity to 80lbs/ft.

\*\* Evenly distributed loads

### Roller Quantity

Length	Roller Centers		
	1.2 (31)	2.4 (61)	3.6 (91)
610 (2)	20	10	6
914 (3)	30	15	10
1,219 (4)	40	20	13
1,524 (5)	50	25	16
1,829 (6)	60	30	20
2,134 (7)	70	35	23
2,438 (8)	80	40	26
2,743 (9)	90	45	30
3,048 (10)	100	50	33
3,353 (11)	110	55	36
3,658 (12)	120	60	40

Dim = mm (ft)

It is recommended that 3 rollers be in contact with the product at all times.

### Connecting Assembly

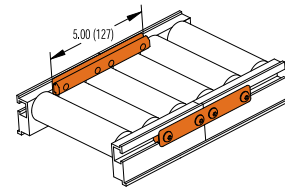

- Includes: Connecting Plates, T-Bars and Attaching Hardware

Part Number	Description
202596M	Model 2260

For support stands and accessories, see pages 76-81.

### 2200 Series Gravity Roller

2 2 6 0 M 0 6 - 0 4 5 0 0 1 / 1 2

- Roller Center Reference
- Select Profile
- Conveyor Length Reference LLLL = Length Reference
- Conveyor Width Reference
- Documentation Language: M = English

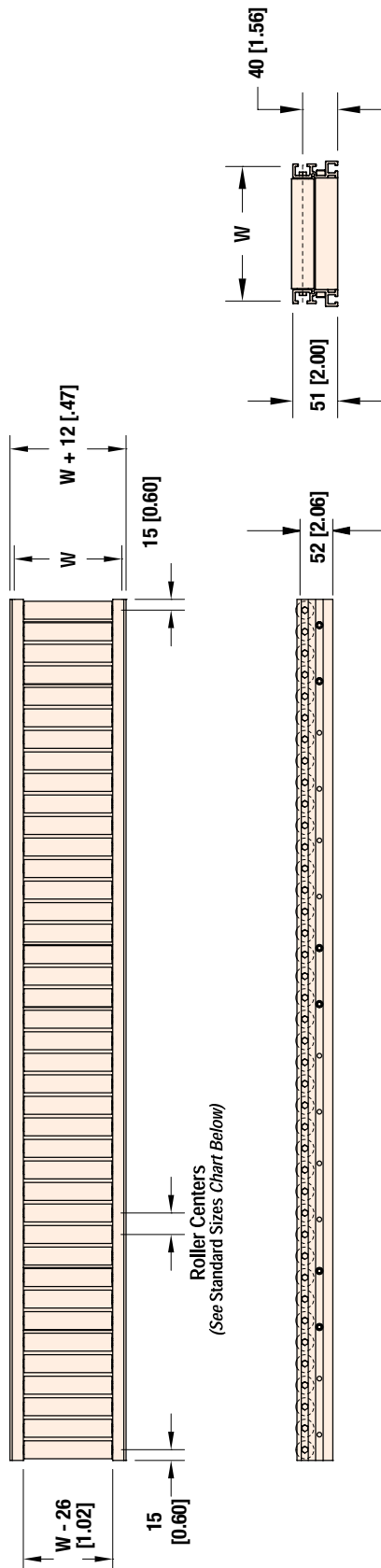

All conveyors are shipped with a roller at each end. Depending on roller centers, one odd roller space may occur. All frames are punched for rollers 15 mm (.60 in) from each end on 31 mm (1.2 in) centers.

$W$  = Conveyor Belt Width     $Dim$  = mm (in)

STANDARD SIZES				
Conveyor Width Reference	06	12	18	24
Conveyor Roller Width (W)	152 mm (6 in)	305 mm (12 in)	457 mm (18 in)	610 mm (24 in)
Conveyor Length Reference	0200	0050 increments up to...		
Conveyor Length (L)	610 mm (2 ft)	152 mm (6 in) increments up to...		
Roller Center Reference	12	24	36	
Roller Centers	31 mm (1.2 in)	61 mm (2.4 in)	91 mm (3.6 in)	

## Fixed Height Supports Stands

Fixed Foot Model			
Stand Width (WW)	305 mm (12 in)	51 mm (2 in) increments up to...	1,219 mm (48 in)
Part # Reference	12	in 02 increments up to...	48
Stand Height (HH)* Belt	381 - 483 mm (15 - 19 in)	in 25 mm (1 in) increments up to...	2,413 - 2,515 mm (95 - 99 in)
Part # Reference Belt	1519	in 0101 increments up to...	9599

- 102 mm (4 in) Height Adjustment
- Provides most access to outside T-Slots
- Includes height indicator

\* Dependent on stand width, stands over 1,067 mm (42 in) may include outriggers (see page 81)

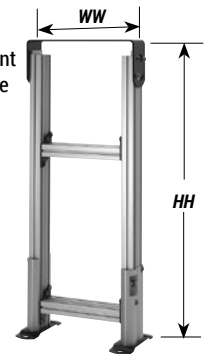

Swivel Locking Caster Model			
Stand Width (WW)	305 mm (12 in)	51 mm (2 in) increments up to...	1,219 mm (48 in)
Part # Reference	12	in 02 increments up to...	48
Stand Height (HH)* Belt	508 - 610 mm (20 - 24 in)	in 25 mm (1 in) increments up to...	1,727 - 1,829 mm (68 - 72 in)
Part # Reference Belt	2024	in 0101 increments up to...	6872

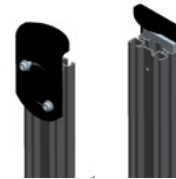

For both the Fixed and Adjustable height stands, width's 305 mm (12 in) and below have a full width plate. For widths larger than 305 mm (12 in) have split brackets.

## Adjustable Height Supports Stands

Fixed Foot Model											
Stand Width (WW)	305 mm (12 in)			51 mm (2 in) increments up to...				1,219 mm (48 in)			
Part # Reference	12			in 02 increments up to...				48			
Stand Height (HH) Belt	12" - 13" (305-330mm)	13" - 15" (330-381mm)	14" - 17" (356-432mm)	16" - 21" (406-660mm)	19" - 26" (483-686mm)	24" - 36" (610-914mm)	30" - 48" (762-1,219mm)	42" - 60"* (1,067-1,524mm)	54" - 72"* (1,372-1,829mm)	66" - 84"* (1,676-2,134mm)	78" - 96"* (1,981-2,438mm)
Part # Reference Belt	1213	1315	1417	1621	1926	2436	3048	4260	5472	6684	7896

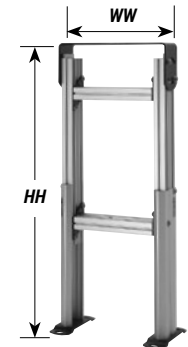

Swivel Locking Caster Model											
Stand Width (WW)	305 mm (12 in)			51 mm (2 in) increments up to...				1,219 mm (48 in)			
Part # Reference	12			in 02 increments up to...				48			
Stand Height (HH) Belt	432-457 mm (17 - 18 in)	457-508 mm (18 - 20 in)	483-559 mm (19 - 22 in)	533-660 mm (21 - 26 in)	610-787 mm (24 - 31 in)	737-1,041 mm (29 - 41 in)	762-1,346 mm (35 - 53 in)	1,194-1,651 mm (47 - 65 in)*	1,499-1,956 mm (59 - 77)*		
Part # Reference Belt	1718	1820	1922	2126	2431	2941	3553	4765	5977		

- Up to 457 mm (18 in) height adjustment range
- Includes height indicator

\* Dependent on stand width, stands over 1,067 mm (42 in) may include outriggers (see page 81)

## Short Support Stands

Fixed Foot Model			
Stand Width (WW)	305 mm (12 in)	51 mm (2 in) increments up to...	1,219 mm (48 in)
Part # Reference	12	in 02 increments up to...	48
Stand Height (HH)* Belt	152 - 203 mm (06 - 08 in)	in 25 mm (1 in) increments up to...	305 - 356 mm (12 - 14 in)
Part # Reference Belt	0608	in 0101 increments up to...	1214

Swivel Locking Caster Model			
Stand Width (WW)	305 mm (12 in)	51 mm (2 in) increments up to...	1,219 mm (48 in)
Part # Reference	12	in 02 increments up to...	48
Stand Height (HH)* Belt	279 - 330 mm (11 - 13 in)	in 25 mm (1 in) increments up to...	305 - 483 mm (17 - 19 in)
Part # Reference Belt	1113	in 0101 increments up to...	1719

- For top belt heights below 508 mm (20 in)
- Full width is top plate on 305 mm (12 in) wide stands only

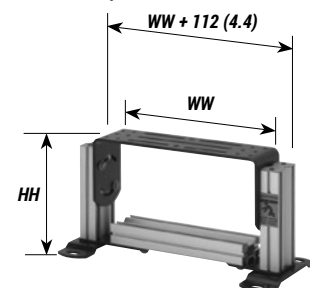

**Note:** Due to the wide variety of conveyor and stand options along with possible configurations, stability of the final setup is the responsibility of the end user.

For ordering information, see page 91

## Fully Adjustable Support Stands

Fixed Foot Model							
Stand Width (WW)	44 mm (1.75 in)	70 mm (2.75 in)	95 mm (3.75 in)	127 mm (5 in)	152 mm (6 in)	51 mm (2 in) increments up to...	1,219 mm (48 in)
Part # Reference	02	03	04	05	06	in 02 increments up to...	48
Top of Belt Range	179 - 483 mm (7 - 19 in)		305 - 787 mm (12 - 31 in)		305 - 1,097 mm (12 - 43 in)		305 - 1,397 mm (12 - 55 in)
Stand Height Reference	0719		1231		1243		1255
Swivel Locking Caster Model							
Stand Width (WW)	44 mm (1.75 in)	70 mm (2.75 in)	3.75" (95 mm)	127 mm (5 in)	152 mm (6 in)	51 mm (2 in) increments up to...	1,219 mm (48 in)
Part # Reference	02	03	04	05	06	in 02 increments up to...	48
Top of Belt Range	305 - 483 mm (12 - 19 in)		432 - 787 mm (17 - 31 in)		432 - 1,097 mm (17 - 43 in)		432 - 1,397 mm (17 - 55 in)
Stand Height Reference	1219		1731		1743		1755

- Provides maximum height adjustment range
- Conveyor is located between stand legs

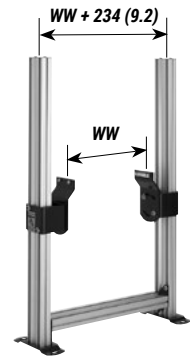

## Quick Adjust Stands

Fixed Foot Model			
Stand Width (WW)*	305 mm (12 in)	5 mm (2 in) increments up to...	914 mm (36 in)
Part # Reference	12	in 02 increments up to...	36
Stand Height (HH)* Belt	610 - 762 mm (24 - 30 in)	in 25 mm (1 in) increments up to...	1,676 - 1,829 mm (66 - 72 in)
Part # Reference Belt	2430	in 0101 increments up to...	6672
Swivel Locking Caster Model			
Stand Width (WW)*	305 mm (12 in)	5 mm (2 in) increments up to...	914 mm (36 in)
Part # Reference	12	in 02 increments up to...	36
Stand Height (HH)* Belt	686 - 838 mm (27 - 33 in)	in 25 mm (1 in) increments up to...	1,524 - 1,676 mm (60 - 66 in)
Part # Reference Belt	2733	in 0101 increments up to...	6066

- Metric fasteners
- +/- 76 mm (3 in) Height Adjustment
- Allows for Quick Height Adjustment
- Tool-less lock and adjustment handles



Fixed Foot Model      Swivel Locking Caster Model

\* Under 305 mm (12 in) wide use full top plate option

### 2200 & 2700 Series Support Stands

3	9	M	T	T	W	W	-	HH (min)	HH (max)	F
										Feet or Casters: F = fixed foot pad    C = total lock swivel caster
										Height Reference
										Width Reference
										Stand Type:
										LH = short stand      FH = fixed height      FA = fully adjustable
										FT = tall fixed*      AT = tall adjustable*
										QA = quick adjust      AH = adjustable height
										Documentation Language: M = US

**EXAMPLE:** 39MAH12-2126CP

**Note:** Due to the wide variety of conveyor and stand options along with possible configurations, stability is final setup of the responsibility of the end user.

\*Tall stands are required when the stand width is 3.5 times the stand height.

**Note:** Due to the wide variety of conveyor and stand options along with possible configurations, stability of the final setup is the responsibility of the end user.

## Support Post Stands

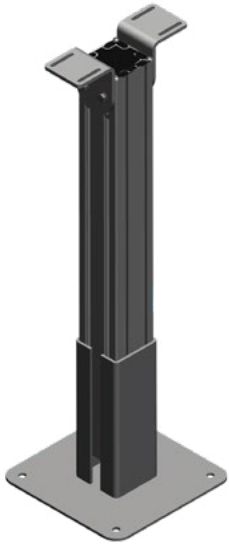

### Specifications

- $\pm 51$  mm (2 in) height adjustment
- Compatible with 51 - 305 mm (2 - 12 in) wide conveyors
- Top of Belt Heights:
  - Minimum = 508 mm (20 in)
  - Maximum = 2,464 mm (97 in)
  - Available in 25 mm (1 in) height increments
- Mounting Configurations:
  - $\pm 30^\circ$  angle mount
- Equipped with a steel base plate for floor mounting
- Stand must be lagged to the floor

#### 2200 Series: Support Post - Beam Type

3 2 0 R P M W W - L H U H

- Tallest Height to Top of Bracket (in inches)
- Lowest Height to Top of Bracket (in inches)
- Width Reference
- Documentation Language: M = US
- Width Range: 3 = 51 - 127 mm (2 - 5 in), 4 = 152 - 203 mm (6 - 8 in), 5 = 254 - 304 mm (10 - 12 in)

## Cantilever Stand Mount (Belted Conveyor Only)



**Easy Access for Quick Belt Removal**

### Specifications

- Widths: 51 mm (2 in) to 610 mm (24 in) available in 25 mm (1 in) increments
- Conveyors up to 152 mm (6 in) wide are supported with a single cantilever bracket only
- Conveyors 203 mm (8 in) and wider include a pivoting outboard support post
- Mounts the conveyor from one side only for quick maintenance of the conveyor belt
- Compatible with the 2200 and 3200 Series Conveyors
- (2) Models
  - Table Top Bracket
  - Support Stand Mount Bracket

#### 2200 Series Cantilever Stand Mount

3 9 M C B W W - T

- Mount Type: T = Table Top Mount S = Support Stand Mount
- Belt Width: 02 to 24



**152 mm (6 in) and narrower**



**203 mm (8 in) and wider**

**Note:** Due to the wide variety of conveyor and stand options along with possible configurations, stability of the final setup is the responsibility of the end user.

## Quantity Charts

Support Stands	
Conveyor Length	Number of Supports
610 - 2743 mm (2 - 9 ft)	2
2744 - 5486 mm (9.01 - 18 ft)	3
5487 - 8230 mm (18.01 - 27 ft)	4
8231 - 9144 mm (27.01 - 30 ft)	5

Required Return Roller Quantity Chart																				
Maximum Distance Between Rollers mm (in)																				
Conveyor Width mm (in)	44 (1.75)	70 (2.75)	95 (3.75)	127 (5)	152 (6)	203 (8)	254 (10)	305 (12)	356 (14)	406 (16)	457 (18)	508 (20)	559 (22)	610 (24)	660 (26)	711 (28)	762 (30)	813 (32)	864 (34)	914 (36)
Flat Belt	2667 (105)	2667 (105)	2286 (90)	2286 (90)	2134 (84)	2057 (81)	1829 (72)	1829 (72)	1829 (72)	1829 (72)	1676 (66)	1676 (66)	1676 (66)	1372 (54)	1372 (54)	1219 (48)	1219 (48)	1219 (48)	1219 (48)	1219 (48)
Cleated Belt	1753 (69)	1753 (69)	1600 (63)	1600 (63)	1448 (57)	1372 (54)	1219 (48)	1219 (48)	1219 (48)	1219 (48)	1067 (42)	1067 (42)	1067 (42)	914 (36)	n/a	n/a	n/a	n/a	n/a	n/a

Quantity of return rollers required = whole  $\frac{\text{conveyor length in mm}}{\text{max distance between return rollers in mm}}$   
 number result of:

**Example:** 2200 flat belt 203 mm wide x 4267 mm long  $\frac{4267 \text{ mm}}{2057} = 2.07$  **2 return rollers required**

**Example:** 2200 flat belt 8 in wide x 14 ft long  $\frac{14 \text{ ft}}{6.75} = 2.07$  **2 return rollers required**

## Mounting Brackets

**Cleated Belt Stand Mounting Bracket**

Part Number	Description
240838	Cleated Belt Conveyor

**Flat Belt & Modular Belt Stand Mounting Bracket**

Part Number	Description
240839	Belted Conveyor 2200
202389	Modular Belt Conveyor
208427	Belted Conveyor 2700
208449	Belted Conveyor 2700 (head plate mount)

**Note:** Conveyors can be ordered with the required number of mounting brackets. If desired, order additional mounting brackets separately.

Dim = mm (in)

**Note:** Due to the wide variety of conveyor and stand options along with possible configurations, stability of the final setup is the responsibility of the end user.

## Return Rollers (Belted Conveyors Only)

### Cleated Belt Return Roller

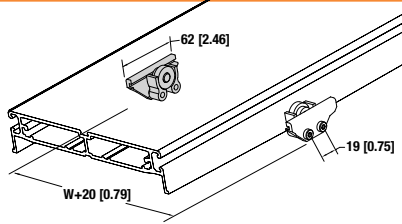

Part Number	Description
206521	Return Roller for Cleated Belt Conveyors

### Flat Belt Return Roller for 44 to 152 mm (2 to 6 in) Wide Conveyors

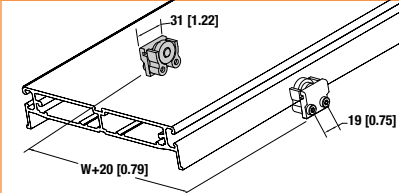

Part Number	Description
206522	Return Roller for 44 mm - 152 mm (2 - 6 in) wide Flat Belt Conveyors

### Flat Belt Return Roller for 203 to 1,219 mm (8 to 48 in) Wide Conveyors

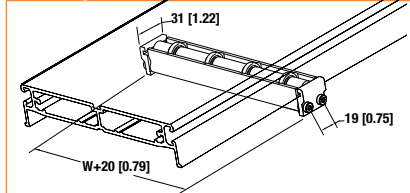

Part Number	Description
206523-WW	Return Roller for 203 - 1,219 mm (8 - 48 in) wide Flat Belt Conveyors

## Stand Accessories

### Adjustable Tie Bracket



- Compatible with steel and aluminum support stands
- Secure critical stand and conveyor locations
- Length (L) adjusts + 0, - 286 mm (11.25 in)
- Includes metric mounting hardware

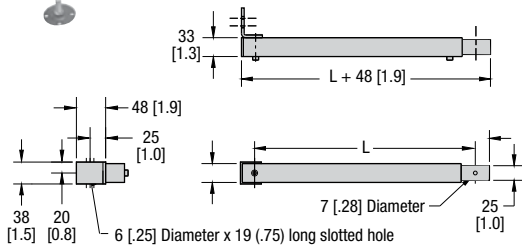

Part Number	Description
27M400-02	Adjustable Tie Bracket, 610 mm (2 ft)
27M400-03	Adjustable Tie Bracket, 914 mm (3 ft)
27M400-04	Adjustable Tie Bracket, 1,219 mm (4 ft)
27M400-05	Adjustable Tie Bracket, 1,524 mm (5 ft)
27M400-06	Adjustable Tie Bracket, 1,829 mm (6 ft)

### Diagonal Bracing



- For use on steel, aluminum and single post support stands with casters
- Metric fastener mounting hardware included
- For use on all stands with casters and any stands over 1829 mm (72 in) tall
- One brace per stand for conveyors up to 610 mm (24 in) wide
- Two braces per stand for conveyors over 610 mm (24 in) wide

Part Number	Description
39MB-TS	for two-legged H style stands up to 762 mm (30 in) tall
39MB-TT	for two-legged H style stands over 762 mm (30 in) tall

**Note:** Due to the wide variety of conveyor and stand options along with possible configurations, stability of the final setup is the responsibility of the end user.

Dim = mm (in)



## Adjustable Lane Guiding (2200 Belted Conveyors only)

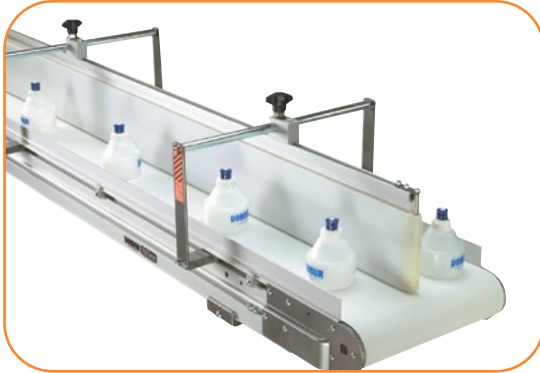

### Specifications

- UHMW guide surface on an anodized aluminum mounting rail
- Painted Steel mounting hardware
- Available in standard 305 mm (1 ft) increments or can be ordered to any length
- 127 mm (5 in) maximum, 7 mm (0.25 in) minimum part height
- 6 mm (0.25 in) minimum lane width
- Package includes one lane guide, mounting hardware and adjusting knobs
- For conveyors up to 610 mm (24 in) wide – Consult factory for wider lane guide availability
- Compatible with standard Dorner bolt-on profiles
- Easily adjusts for quick product change over
- Attach additional guides to create multiple lanes
- Create lanes, plows, merges and transfers
- Order additional lane kits separately

### 2200 Series Adjustable Lane Guiding

27M GGG - WW LL

— Conveyor Length Reference  
— Conveyor Width Reference

— Guide Type:

500 = 2200 Package (Belted)  
502 = Additional Lane Guide

Example: 27M500-0620

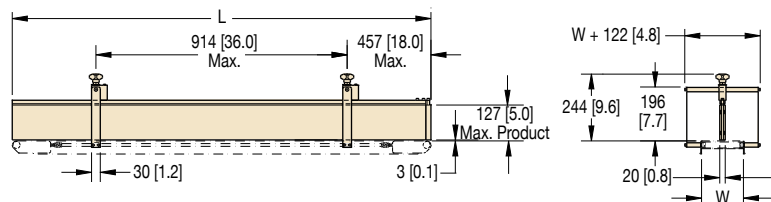

**Important:** Exceeding 127 mm (5 in) product height will produce a pinch point.

## Side Tables



### Specifications

- Provides a 152 mm (6 in) or 305 mm (12 in) wide working surface
- Adjusts in/out and up/down (7 mm [0.25 in] max above bedplate) for product transfer on/off conveyor belts
- Can be positioned anywhere along the conveyor
- Anodized aluminum work surface
- Max load: 6 kg/m (5 lbs/ft), use Adjustable Tie Brackets for added capacity
- Available in 305 mm (1 ft) increments from 305 mm (1 ft) to 30,175 mm (99 ft)

### 2200 Series Side Tables

27M TTT - 06 LLLL

— Table Length  
ex. 0200 = 610 mm (2 ft)

— Table Width:  
06 = 152 mm (6 in)  
12 = 610 mm (12 in)

— Conveyor / Table Type:

601 = one side  
602 = two sides

Example: 27M601-060200

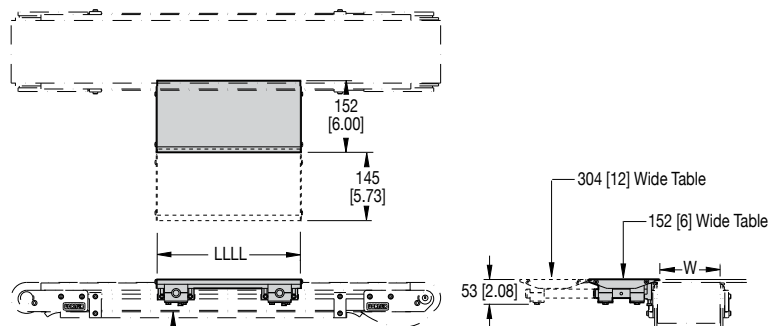

Supports can be positioned anywhere along table

LLLL = 305 to 30,175 mm (1 to 99 ft); Maximum 2,438 mm (8 ft) length single piece

Dim = mm (in)

90° Adjustable Transfer (2200 Belted Conveyor Only)

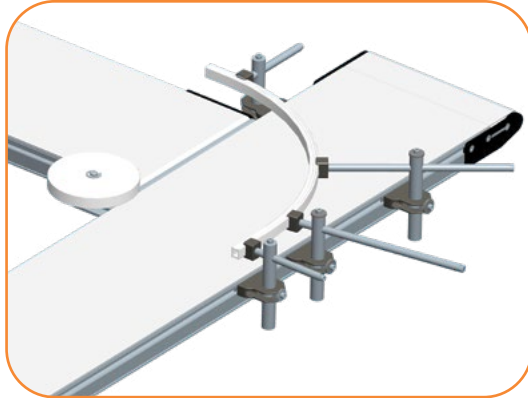

Specifications

- For conveyors up to 305 mm (12 in) wide
- Requires low side conveyors
- 6 mm (0.25 in) minimum part thickness
- Hard coat anodized transfer plate
- Painted steel mounting hardware
- 1,219 mm (48 in) long UHMW outside turn guide, customer can trim to fit
- Maximum recommended part weight is 9 kg (20 lbs) at 15 m/min (50 ft/min) belt speed – Consult factory regarding applications for higher product weights or faster belt speeds.
- 22 mm (0.88 in) minimum product size for 2200 Series
- Package includes outside turn guide, guide wheel, adjustable mounting hardware and extruded aluminum transfer plate
- Pre-engineered guided turns adjust to a variety of products
- Accepts standard Dorner bolt-on profiles outside of transfer area
- Place adjusting rods where required
- Easily adjusts for quick product change-over

Part Number	Description
206524-WW*	2200 Series 90° Adjustable Transfer

\*WW = Width in inches

**Note:** Due to the wide variety of drive setups and applications point of installation guarding is the responsibility of the end user.

**Important:** Do not use with 03, 08, 55, 62, or 64 High Friction Belts on Infeed conveyor

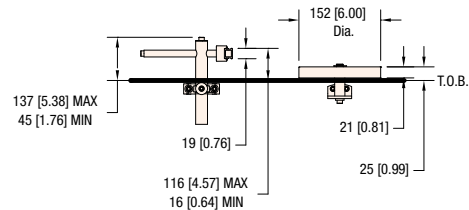
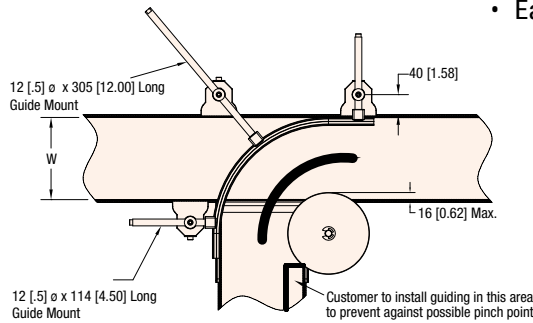

Pulley Transfer Plate (2200 Belted Conveyor Only)

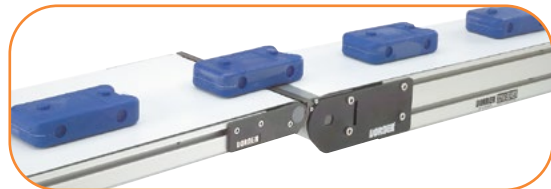

Specifications

- 22 mm (0.88 in) diameter minimum product transfer
- 300 series stainless steel transfer plate

Part Number	Description
207218-WW	2200 Series Pulley Transfer Plate

WW = Conveyor Width Reference

Not compatible with clipper splice or high friction belts  
Not compatible with cleated belt conveyors

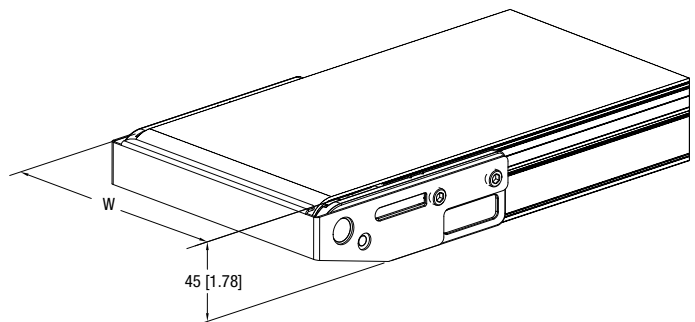

Dim = mm (in)

## T-Slot Hardware Accessories

### Spring T-Nut

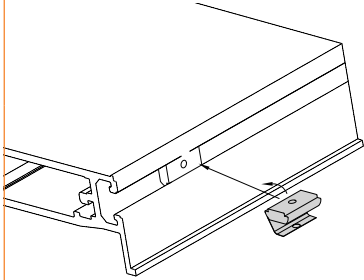

- Retains position in T-slot

Part Number	Description
205504	M4 x 0.7 Spring Nut
205505	M5 x 0.8 Spring Nut
205506	M6 x 1.0 Spring Nut
205508	M8 x 1.25 Spring Nut
207443	1/4 x 20 Spring Nut

### T-Bars

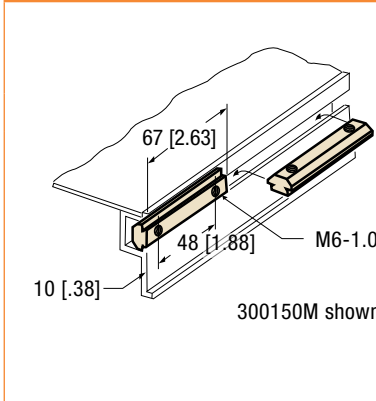

- Mounts in T-slots to attach heavy accessories

Part Number	Description
639971M	M6 x 1.0, T-bar, 1 hole, 19 mm (0.75 in) long
202390M	M8 x 1.25, T-bar, 1 hole, 16 mm (0.63 in) long
643874M	M6 x 1.0, T-bar, 2 hole, 19 mm (0.75 in) centers, 38 mm (1.5 in) long
200626M	M6 x 1.0, T-bar, 2 hole, 22 mm (0.875 in) centers, 41 mm (1.62 in) long
200830M	M6 x 1.0, T-bar, 2 hole, 25 mm (1.0 in) centers, 44 mm (1.75 in) long
639717M	M6 x 1.0, T-bar, 2 hole, 32 mm (1.25 in) centers, 51 mm (2 in) long
300150M	M6 x 1.0, T-bar, 2 hole, 48 mm (1.875 in) centers, 2.52" long
300536M	M6 x 1.0, T-bar, 2 hole, 54 mm (2.125 in) centers, 73 mm (.88 in) long
639971	1/4 x 20, T-bar, 1 hole, 19 mm (0.75 in) long
300150	1/4 x 20, T-bar, 2 hole, 48 mm (1.875 in) centers, 67 mm (2.62 in) long

### T-Bolts & T-Nuts

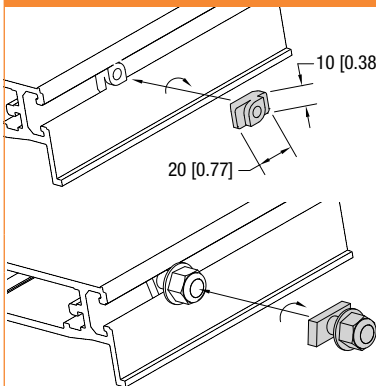

- Mounts in T-slots to attach accessories
- 1/2 turn install and remove
- T-nut requires thread lock screw

Part Number	Description
203446	M8 x 20mm long Twist Bolt and Nut, Package of 5
203447	M8 x 35mm long Twist Bolt and Nut, Package of 5
206685	M6 Twist T-Nut

### T-Slot Extenders

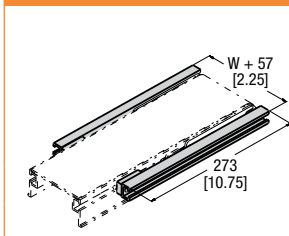

- Provides additional T-slots to the end of conveyor
- Includes mounting brackets and hardware
- Metric fasteners

Part Number	Description
307000M	T-Slot Extender, Pair

### T-Slot Cover

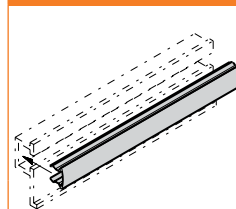

- Snaps into conveyor and aluminum stand T-slots
- Black plastic extrusion
- Can be trimmed to fit

Part Number	Description
645656P	T-Slot Cover, Per 1' (305 mm) of length

Dim = mm (in)

Due to the wide variety of drive set ups and applications, point of installation guarding is the responsibility of the end user.

Side Guides (2200 Belted Conveyor Only)

Flared Side Guide

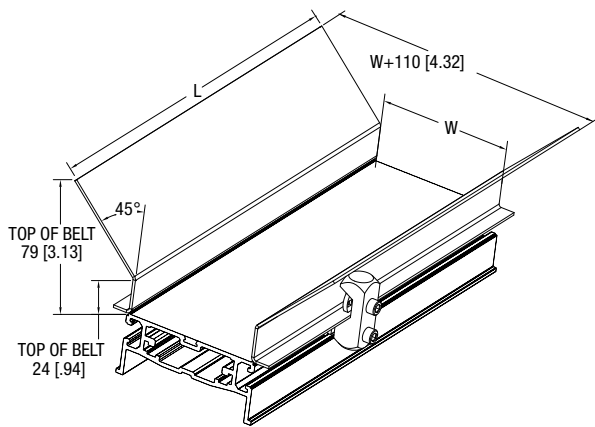

- Guides parts onto conveyor belt surface
- Includes metric mounting hardware

Part Number	Description
280802M	610 mm (2 ft) Flared Side
280803M	914 mm (3 ft) Flared Side
280804M	1,219 mm (4 ft) Flared Side
280805M	1,524 mm (5 ft) Flared Side
280806M	1,829 mm (6 ft) Flared Side

Stops

Adjustable Stop\*

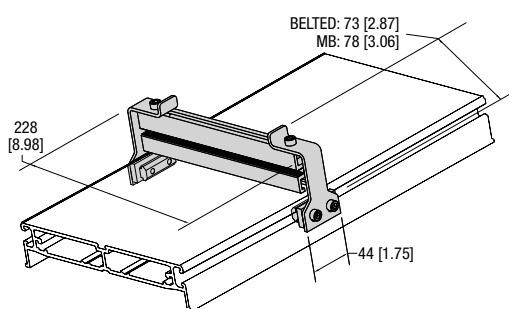

- Slides up and down T-slot length
- Includes metric mounting hardware

Part Number	Description
207133-WW	Adjustable Stop: Belted
207137-WW	Adjustable Stop: Modular Belt and Precision Move

**WW** = Conveyor Width Reference  
 \* Not compatible with high friction belts  
 \* Not compatible with cleated belt conveyors

End Stop\* (2200 only)

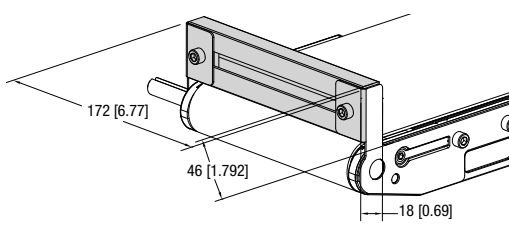

- Anodized aluminum stop
- Includes tail plates and mounting hardware

Part Number	Description
207213-WW	End Stop: Belted
207214-WW	End Stop: Precision Move
207215-WW	End Stop: Modular Belt

**Note:** Not compatible with gang drive, nosebar, cleated belt, or modular belt center drive options

Roller Conveyor End Stop

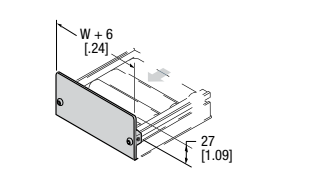

- Includes metric mounting hardware

Part Number	Description
202668-WW	Roller End Stop

Dim = mm (in)

Due to the wide variety of drive set ups and applications, point of installation guarding is the responsibility of the end user.

## Brackets

### Adjustable Height Bracket ‡

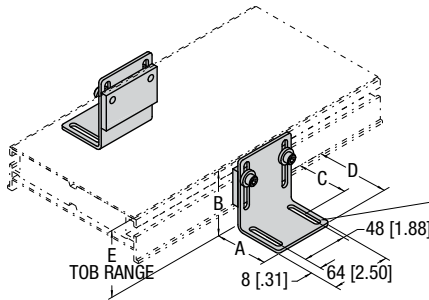

- Provides height adjustment
- (2) Height Ranges
- Includes mounting hardware

Part Number	Description	A	B	C	D	E
201557	51 x 76 mm (2 x 3 in) Bracket	51 (2)	76 (3)	36 (1.4)	61 (2.4)	97 to 135 (3.83 to 5.33)
201558	76 x 127 mm (3 x 5 in) Bracket	76 (3)	127 (5)	51 (2)	86 (3.4)	133 to 184 (5.23 to 7.23)

### Table Top Mounting Bracket ‡

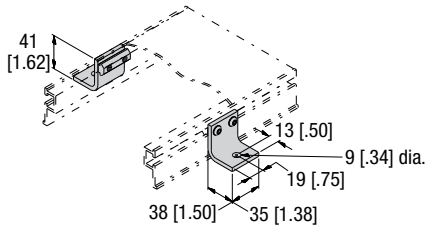

- Includes metric mounting hardware

Part Number	Description
200349M	Table top bracket

‡ = If the discharge end of conveyor is mounted over a table or similar structure, the customer must provide guiding to prevent against possible pinch point.

### Frame Mount Casters (2200 Belted Conveyor Only)

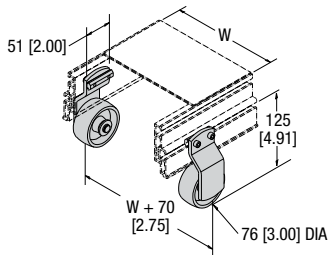

- Includes metric mounting hardware

\*Provides floor to T-Slot height of: 125mm (4.94 in)

Part Number	Description
390207	Frame mount casters, pair

### Floor Mount Brackets

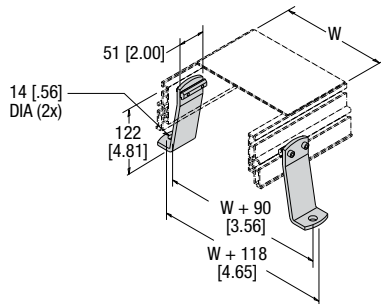

- Includes metric mounting hardware

\*Provides floor to T-Slot height of: 122mm (4.81 in)

Part Number	Description
390217	Floor mount brackets, pair

WW = Conveyor Width Reference

Dim = mm (in)

Due to the wide variety of drive set ups and applications, point of installation guarding is the responsibility of the end user.

Drive Shaft Accessories

**Clear Cover**



• Fits 2200 light load top mount and standard and heavy load top and bottom mount packages

Part Number	Description
689499M	Clear cover, ordered separately

**Spline Shaft**



• Compatible with Precision Move Gang Mid Drive

Part Number	Description
202432-04800	13 mm (½ in) diameter x 16 tooth x 1219 mm (4 ft) long Spline Shaft

**Flexible Coupling**

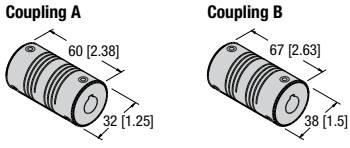

• (A) Includes SAE set screws, (B) metric set screws

Part Number	Description	Coupling
23M29	Flexible Coupling, 12 mm bore x 10 mm (0.38 in) hex	A
23M31	Flexible Coupling, 12 mm bore x 12 mm bore	B

Dim = mm (in)

Due to the wide variety of drive set ups and applications, point of installation guarding is the responsibility of the end user.

## Guide Mounts

### Guide Mount Brackets for Adjustable Profiles

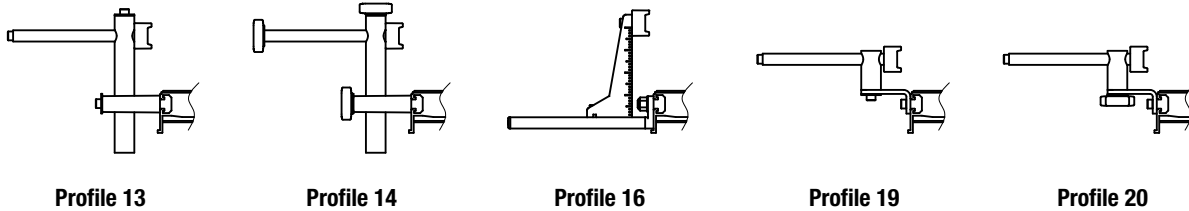

Part Number	Description
206686	Fully adjustable guide mount assembly (Profiles 13, 33 & 43)
206687	Tool-less Fully adjustable guide mount assembly (Profiles 14, 34 - 44)
206193	Outboard guide mount assembly (Profiles 16, 36 & 46)
207150	Belted horizontal only guide mount assembly (Profiles 19, 39 & 49)
207151	Belted tool-less horizontal only guide mount assembly (Profiles 20, 40 & 50)

**Note:** Order guide extrusion separately

### Overhead Guide Mounting Bracket

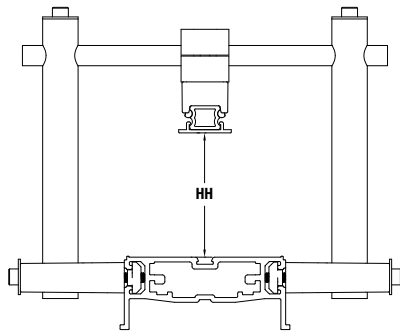

Part Number	Description
206185-WW-03	Adjustable 0-76 mm (3 in) Overhead Guide Mount Bracket
206185-WW-05	Adjustable 0-127 (5 in) Overhead Guide Mount Bracket
206185-WW-08	Adjustable 0-203 mm (8 in) Overhead Guide Mount Bracket

**Note:** Order guide extrusion separately

### Dual Guide Mounting Bracket

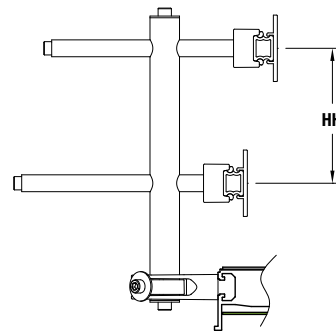

Part Number	Description
206186-02	Dual Guide Bracket, 50 mm (2 in) Between Guides
206186-03	Dual Guide Bracket, 76 mm (3 in) Between Guides
206186-04	Dual Guide Bracket, 102 mm (4 in) Between Guides

**Note:** Order guide extrusion separately

### Adjustable Guide Rail Extrusion



**Aluminum Extrusion**



**50 mm [2 in] HDPE Extrusion**



**33 mm [1.3 in] HDPE Extrusion**

Part Number	Description
GTB13A04	Adjustable guide aluminum extrusion, 1219 mm (4 ft) long
GTB13A08	Adjustable guide aluminum extrusion, 2438 mm (8 ft) long
GTB13B04	Adjustable guide 33 mm (1.3 in) HDPE Cover, 1219 mm (4 ft) long
GTB13B08	Adjustable guide 33 mm (1.3 in) HDPE Cover, 2438 mm (8 ft) long
GTB13C04	Adjustable guide 50 mm (2 in) HDPE Cover, 1219 mm (4 ft) long
GTB13C08	Adjustable guide 50 mm (2 in) HDPE Cover, 2438 mm (8 ft) long
GTB13P04	Adjustable guide HDPE extrusion, 1219 mm (4 ft) long
GTB13P08	Adjustable guide HDPE extrusion, 2438 mm (8 ft) long

**Note:** Order guide mount brackets separately

Guide Mounts (continued)

Adjustable Guide Rail Accessories

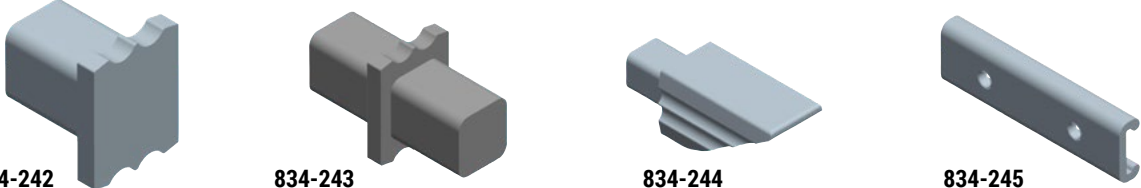

Part Number	Description
834-242	End cap for aluminum guide extrusion, 10 pack
834-243	Plastic plug connecting piece for aluminum guide extrusion, 10 pack
834-244	Lead in for aluminum guide extrusions, 10 pack
834-245	Aluminum connection piece for aluminum guide extrusion, 10 pack

Note: Order guide extrusion separately

Bolt on Guide Clip Assembly

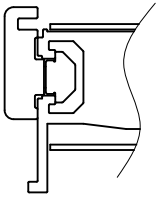

Part Number	Description
203661	For use with all High Side Guide Profiles

Note: Order guide extrusion separately

High Side Guide Rails

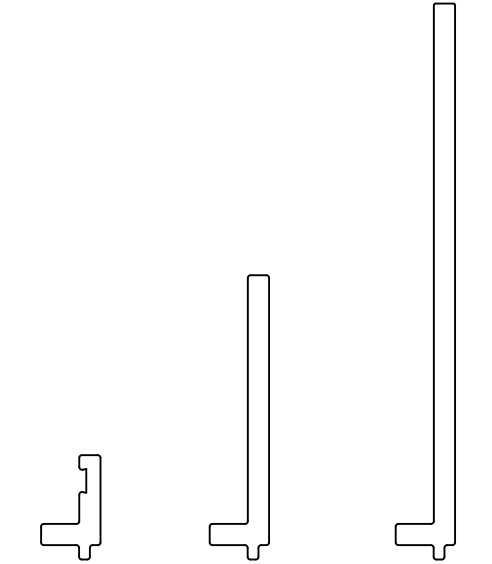

Part Number	Description
GTB09A04	13 mm (0.5 in) Aluminum High Side guide extrusion 1219 mm (4 ft) long
GTB09A08	13 mm (0.5 in) Aluminum High Side guide extrusion 2438 mm (8 ft) long
GTB05A04	38 mm (1.5 in) Aluminum High Side guide extrusion 1219 mm (4 ft) long
GTB05A08	38 mm (1.5 in) Aluminum High Side guide extrusion 2438 mm (8 ft) long
GTB04A04	76 mm (3.0 in) Aluminum High Side guide extrusion 1219 mm (4 ft) long
GTB04A08	76 mm (3.0 in) Aluminum High Side guide extrusion 2438 mm (8 ft) long

## Regulatory Approvals:







### Conveyors:

All Dorner 2200 Series standard conveyors (not including gearmotors and controllers) are CE approved. CE approval follows the provisions of the following directives; Machine Directive 2006/42/EC, EU Low Voltage Directive 2006/95/EC, and EMC Directive 2004/108/EC. All conveyors are marked with the CE symbol on the Dorner serial number tag located on the conveyor frame. Contact the factory for the CE Declaration of Conformity.

All Dorner 2200 Series standard conveyors (not including gearmotors and controllers) are designed and manufactured in accordance with the restrictions defined in the "Restriction of Hazardous Substances" directive, citation 2002/95/EC, commonly known as RoHS. All conveyors are marked with the RoHS symbols on the Dorner serial number tag located on the conveyor frame.

### Gearmotors and Controllers:

All Dorner 2200 Series gearmotors and controllers carry one or more of the following approvals. Products are not covered by each approval. Please see the appropriate part number on the Gearmotor and controller charts located in this manual. In addition, regulatory symbols are located on the product information tags located on the product.

	<p>CE Marking on a product is a manufacturer's declaration that the product complies with the essential requirements of the relevant European health, safety and environmental protection legislation, in practice by the Product Directives. CE Marking on a product ensures the free movement of the product within the European Union (EU).</p>
	<p>This directive restricts (with exceptions) the use of six hazardous materials in the manufacture of various types of electronic and electrical equipment. It is closely linked with the Waste Electrical and Electronic Equipment Directive (WEEE) 2002/96/EC which sets collection, recycling and recovery targets for electrical goods and is part of a legislative initiative to solve the problem of huge amounts of toxic e-waste.</p>
	<p>The UL Recognized Component mark is for products intended to be installed in another device, system or end product. This Recognized Component Mark is for the United States only. When a complete product or system containing UL Recognized Components is evaluated, the end-product evaluation process can be streamlined.</p>
	<p>The UL Recognized Component mark is for products intended to be installed in another device, system or end product. This Recognized Component Mark is for the United States and Canada. When a complete product or system containing UL Recognized Components is evaluated, the end-product evaluation process can be streamlined.</p>
	<p>CSA International (Canadian Standards Association), is a provider of product testing and certification services for electrical, mechanical, plumbing, gas and a variety of other products. Recognized in the U.S., Canada and around the world, CSA certification marks indicate that a product, process or service has been tested to a Canadian or U.S. standard and it meets the requirements of an applicable CSA standard or another recognized document used as a basis for certification.</p>
	<p>The UL Listing Mark means UL found that representative product samples met UL's safety requirements. These requirements are primarily based on UL's own published standards for safety. The C-UL-US Mark indicates compliance with both Canadian and U.S. requirements. The products with this type of Mark have been evaluated to Canadian safety requirements and U.S. safety requirements.</p>

### Clean Room Certifications:

The 2200 Series Conveyors are often used in clean room applications where the generation of particulates from the conveyor are a concern. In these applications the correct installation and application of the conveyor is critical to the proper running of the conveyor and minimizing the dust generated by the conveyor belt or modular belt. The end user must ensure that the conveyor belts are properly tracked and product accumulation is minimized to providing minimal dust generation.

All of the 2200 Series products are designed and constructed to be used in clean room environments. The following 2200 Series products have gone through third party testing and certification and are certified for use in ISO Standard 14644-1 Class 5 and Federal Standard 209 Class 100 Clean Room applications.

**2200 Series Belted Conveyor**

**2200 Series Precision Move Conveyor**

Contact the factory for copy of the certification.



## Materials and Chemical Resistance:

Conveyor Frames, Plastics and Modular Belting	
The following is a list of base materials used in the 2200 Series conveyor:	
Material	Conveyor Component
Acetal Copolymer, POM	Modular Belts, molded bearing housings
Polypropylene, PP	Modular Belts
Polyamide, PA	Adjustable Guide Support Brackets
UHMW-PE	Modular Belt Slide Rail, Adjustable Guide Face
Thermoplastic Elastomer, TPE	Modular Belt Friction Insert
Aluminum, anodized (Note: cut ends of aluminum is not anodized)	Conveyor Frame, Support Legs, High Side Guiding, Adjustable Guide Horizontal Post, Adjustable Guide Rail

The materials used in the 2200 & 2700 Series product can resist many chemicals, however some should be avoided. Avoid the following:

- Acids with PH less than 4
- Bases with PH higher than 9

Resistance to Materials: Conveyor Frames, Plastics and Modular Belting					
The following table provides the resistance to materials used in the conveyor to several chemicals. Application testing is recommended to determine long term material durability.					
<b>Legend:</b>					
1 = Very good resistance   2 = Good resistance   3 = Moderate resistance   4 = Not recommended   X = no data available					
Acids	Acetal POM	Polypropylene	Polyamide PA	UHMW-PE	Aluminum
Acetic acid	3	1	4	1	2
Benzoic acid	3	1	4	1	4
Boric acid	3	1	2	1	2
Citric acid	3	1	2	1	2
Chromic acid	4	1	4	1	3
Hydrofluoric acid	4	1	4	1	4
Hydrochloric acid	4	1	4	1	3
Hydro cyanic acid	4	X	4	1	1
Nitric acid	4	1	4	1	3
Oleic acid	3	1	2	1	1
Oxalic acid	4	1	2	1	1
Phosphoric acid	4	1	4	1	3
Sulphuric acid	4	2	4	1	3
Tartaric acid	3	1	2	1	1
Basic Compounds	Acetal POM	Polypropylene	Polyamide PA	UHMW-PE	Aluminum
Ammonia	1	1	2	1	2
Calcium hydroxide	1	X	2	1	4
Caustic soda	1	X	2	1	3
Potassium hydroxide	1	1	2	1	4

Resistance to Materials: Conveyor Frames, Plastics and Modular Belting <i>(continued)</i>					
<b>Legend:</b> 1 = Very good resistance   2 = Good resistance   3 = Moderate resistance   4 = Not recommended   X = no data available					
<b>Salts</b>	<b>Acetal POM</b>	<b>Polypropylene</b>	<b>Polyamide PA</b>	<b>UHMW-PE</b>	<b>Aluminum</b>
Potassium bicarbonate	2	X	2	1	1
Potassium permanganate	2	2	4	1	1
Sodium cyanic	2	X	2	1	4
Sodium hydrochloride	3	X	4	1	4
Acid salt	2	X	3	1	X
Basic salt	1	X	2	1	X
Neutral salt	1	X	2	1	X
<b>Organic Compounds</b>	<b>Acetal POM</b>	<b>Polypropylene</b>	<b>Polyamide PA</b>	<b>UHMW-PE</b>	<b>Aluminum</b>
Acetone	1	1	1	1	1
Aniline	2	1	3	1	1
Benzene	1	3	2	4	1
Benzine	2	X	2	3	1
Butyl alcohol	2	X	2	1	1
Carbon disulphide	1	3	2	3	1
Carbon tetrachloride	1	3	1	3	2
Chloroform	1	4	3	4	X
Ethyl acetate	1	1	2	1	1
Ethyl alcohol	1	X	2	1	1
Heptane	2	1	1	2	X
Methyl alcohol	1	X	2	1	2
Methyl ethyl ketone	1	2	1	2	2
Nitrobenzene	2	2	2	1	1
Phenol	3	1	4	1	1
<b>Gases</b>	<b>Acetal POM</b>	<b>Polypropylene</b>	<b>Polyamide PA</b>	<b>UHMW-PE</b>	<b>Aluminum</b>
Carbon dioxide	3	1	1	1	1
Carbon monoxide	2	X	1	1	1
Chlorine	2	4	4	3	1
Hydrogen Sulfide	3	1	1	1	1
Sulphur dioxide	2	1	3	1	1
<b>Other</b>	<b>Acetal POM</b>	<b>Polypropylene</b>	<b>Polyamide PA</b>	<b>UHMW-PE</b>	<b>Aluminum</b>
Carbon tetrachloride	1	3	1	3	2
Beer	1	1	2	1	1
Fruit juice	1	2	2	1	2
Gasoline	1	1	2	1	1
Milk	1	1	1	1	1
Oil	1	3	1	1	1
Vinegar	1	1	2	1	1

### Belting:

The following is a list of the top coat materials used in 2200 Series conveyor belting:

Material	Belt Number
Urethane	01, 02, 03, 05, 06, 09, 54, 55, 56, 53, 60, 61, 63, 68, 69, 72, 73, 75, 76, 77
PVC (non FDA approved)	08, 18, 59, 64
Silicone	50, 80, 81
Polyester	66
Nitrile	57
Urethane (hard)	58

### Resistance to Materials: Belting

The following table provides the resistance to belt materials used in the conveyor to several chemicals. Application testing is recommended to determine long term material durability.

#### Legend:

1 = Good resistance | 3 = Limited resistance | 4 = Not recommended

Materials	Urethane	PVC (non FDA)	Silicone	Polyester	Urethane (hard)
<b>Chemicals</b>					
Acetic acid (glacial acetic acid)	4	3	1	1	4
Acetic acid 10 %	3	1	1	3	1
Acetic anhydride	3	4	1	1	4
Acetone	4	4	1	3	4
Aluminium salts	1	1	1	1	1
Alum	1	1	1	1	1
Ammonia, aqueous	3	1	1	3	1
Ammonia, gaseous	1	1	3	1	1
Ammonium acetate	1	1	1	1	1
Ammonium carbonate	1	1	1	1	1
Ammonium chloride	1	1	1	1	1
Ammonium nitrate	1	1	1	1	1
Ammonium phosphate	1	1	1	1	1
Ammonium sulphate	1	1	1	1	1
Amyl alcohol	1	4	3	1	1
Aniline	3	3	3	4	4
Barium salts	1	1	1	1	1
Benzaldehyde	4	4	4	4	4
Benzine (see also Motor fuels)	1	3	3	1	1
Benzoic acid	1	1	1	1	1
Benzol	3	4	4	3	3
Boric acid	1	1	1	1	1
Boric acid, solution	1	1	1	1	1
Bromine	4	4	4	4	4
Bromine water	4	3	1	4	3
Butane, gaseous	1	1	1	1	1
Butane, liquid	1	1	1	1	1
Butyl acetate	4	4	4	3	4
n-Butyl alcohol	1	3	1	1	1
Calcium chloride	1	1	1	1	1
Calcium nitrate	1	1	1	1	1

Resistance to Materials: Belting (continued)					
Legend: 1 = Good resistance   3 = Limited resistance   4 = Not recommended					
Materials	Urethane	PVC (non FDA)	Silicone	Polyester	Urethane (hard)
Calcium sulphate	1	1	1	1	1
Carbon disulphide	4	4	3	4	4
Carbon tetrachloride	3	4	4	4	3
Chlorine, liquid	4	4	4	4	4
Chlorine, gaseous, dry	4	4	4	4	4
Chlorine, gaseous, wet	4	4	4	4	4
Chlorine water	4	1	3	4	3
Chlorobenzene	4	4	4	4	4
Chloroform	4	4	4	4	4
Chlorosulphonic acid	4	4	4	4	4
Chromic acid	4	4	4	4	4
Chromium salts	1	1	1	1	1
Chromium trioxide	1	1	1	1	1
Citric acid	4	1	1	1	4
Copper salts	1	1	1	1	3
Cresols	3	3	3	4	3
Cresols, aqueous	3	3	3	3	3
Cyclohexane	4	4	4	1	4
Cyclohexanol	4	4	4	4	4
Cyclohexanone	4	4	4	4	4
Decahydronaphthalene	4	4	4	4	4
Dibutyl phthalate	3	4	1	4	4
Diethyl ether	4	4	4	4	4
Dimethyl formamide	4	4	3	4	4
1,4 Dioxan	4	4	3	4	4
Ether	4	4	4	4	4
Ethyl acetate	4	4	4	3	4
Ethyl alcohol, non-denatured 100%	1	3	3	1	1
Ethyl alcohol, non-denatured 96%	1	3	3	1	1
Ethyl alcohol, non-denatured 50%	1	3	3	1	1
Ethyl alcohol, non-denatured 10%	1	3	1	1	1
Ethyl benzene	4	4	4	4	4
Ethyl chloride	4	4	4	4	4
Ethylene chloride	4	4	4	4	4
2-Ethyl hexanol	1	3	1	1	1
Formaldehyde	1	3	1	3	1
Formic acid, dilute	4	1	1	3	3
Glycerine	1	1	1	1	1
Glycerine, aqueous	1	1	1	1	1
Glycol	1	3	1	1	1
Glycol, aqueous	1	1	1	1	1
Heptane	1	3	3	1	1
Hexane	1	3	3	1	1
Hydrochloric acid, conc.	3	1	4	3	1

Resistance to Materials: Belting (continued)					
Legend: 1 = Good resistance   3 = Limited resistance   4 = Not recommended					
Materials	Urethane	PVC (non FDA)	Silicone	Polyester	Urethane (hard)
Hydrochloric acid 10 %	3	1	1	1	1
Hydrofluoric acid 40 %	4	4	4	4	4
Hydrogen chloride, gaseous, dilute	3	1	3	3	1
Hydrogen chloride, gaseous, conc.	3	3	3	4	3
Hydrogen peroxide 10%	3	1	1	3	1
Hydrogen sulphide	3	3	3	3	3
Iron salts (sulphate)	1	1	1	1	1
Isooctane	1	3	3	1	1
Isopropyl alcohol	1	3	1	1	1
Lactic acid	1	3	1	1	1
Magnesium salts	1	1	1	1	1
Mercury	1	1	1	1	1
Mercury salts	1	1	1	1	1
Methyl alcohol, aqueous 50 %	3	3	1	1	1
Methyl alcohol (methanol)	1	3	1	1	1
Methyl ethyl ketone	4	4	1	3	4
Methylene chloride	4	4	4	4	4
Naphthalene	3	4	4	3	4
Nickel salts	1	1	1	1	1
Nitric acid	4	3	4	4	4
Nitrobenzene	4	4	1	3	4
Octane (see also isooctane)	1	3	4	1	1
Oleic acid	1	3	4	1	1
Oxalic acid	1	1	1	1	1
Ozone	1	3	3	1	3
Perchloroethylene	4	4	4	4	4
Phenol	3	3	1	4	3
Phenol, aqueous	4	3	1	4	3
Phosphoric acid 85 %	4	1	1	3	1
Phosphoric acid 50 %	1	1	1	1	1
Phosphoric acid 10 %	1	1	1	1	1
Phosphorus pentoxide	1	1	1	1	1
Potash lye 50 %	4	1	4	3	4
Potash lye 25 %	4	1	4	1	4
Potash lye 10 %	4	1	3	1	4
Potassium carbonate (potash)	1	1	1	1	1
Potassium chlorate	1	1	1	1	1
Potassium chloride	1	1	1	1	1
Potassium dichromate	1	1	1	1	1
Potassium iodide	1	1	1	1	1
Potassium nitrate	1	1	1	1	1
Potassium permanganate	1	1	1	1	1
Potassium persulphate	1	1	1	1	1
Potassium sulphate	1	1	1	1	1
Propane, gaseous	1	1	1	1	1

Resistance to Materials: Belting <i>(continued)</i>					
Legend: 1 = Good resistance   3 = Limited resistance   4 = Not recommended					
Materials	Urethane	PVC (non FDA)	Silicone	Polyester	Urethane (hard)
Propane, liquid	1	1	1	1	1
Pyridine	4	4	3	4	4
Silver salts	1	1	1	1	1
Soda lye 50% (see potash lye)	4	1	4	4	4
Soda lye 25%	4	1	4	3	4
Soda lye 10%	4	1	3	1	4
Sodium bisulphite	1	1	1	1	1
Sodium carbonate (natron)	1	1	1	1	1
Sodium carbonate (soda)	1	1	1	1	1
Sodium chlorate	1	1	1	1	1
Sodium chloride (common salt)	1	1	1	1	1
Sodium hydroxide (caustic soda)	4	1	4	1	4
Sodium hypochlorite	1	1	1	3	1
Sodium nitrate	1	1	1	1	1
Sodium nitrite	1	1	1	1	1
Sodium perborate	1	1	1	1	1
Sodium phosphate	1	1	1	1	1
Sodium sulphate (Glauber salt)	1	1	1	1	1
Sodium sulphide	1	1	1	1	1
Sodium sulphite	1	1	1	1	1
Sodium thiosulphate (fixing salt)	1	1	1	1	1
Stearic acid	1	1	1	1	1
Succinic acid	1	1	1	1	1
Sulphur	1	1	1	1	1
Sulphur dioxide	3	3	3	3	4
Sulphuric acid 96%	4	4	4	4	4
Sulphuric acid 50%	4	3	4	3	4
Sulphuric acid 25%	4	3	3	1	3
Sulphuric acid 10%	4	3	1	1	3
Tartaric acids	1	1	1	1	1
Tetrachloroethane	4	4	4	4	4
Tetrachloroethylene (perchloroethylene)	4	4	4	4	4
Tetrahydrofuran	4	4	4	4	4
Tetrahydronaphthalene	4	4	4	4	4
Thiophene	4	4	4	4	4
Tin II chlorides	1	1	1	1	1
Toluene	4	4	4	4	4
Trichloroethylene	4	4	4	4	4
Urea, aqueous	1	1	1	1	1
Water	1	1	1	1	1
Xylene	4	4	4	3	4
Zinc salts	1	1	1	1	1

Resistance to Materials: Belting (continued)					
Legend:					
1 = Good resistance   3 = Limited resistance   4 = Not recommended					
Materials	Urethane	PVC (non FDA)	Silicone	Polyester	Urethane (hard)
<b>Products</b>					
Alum	1	1	1	1	1
Anti-freeze*	1	3	1	1	1
Aqua regia	4	4	4	4	4
Asphalt	1	3	3	1	1
Battery acid	4	4	4	4	4
Benzine	1	3	3	1	1
Bleaching lye (12.5%)	1	1	1	1	3
Bone oil	1	3	4	1	1
Borax	1	1	1	1	1
Brake fluid* Bosch	1	3	1	1	3
Brake fluid* Skydrol	4	4	3	4	4
Chloride of lime (aqueous suspension)	1	1	1	1	3
Chlorine (active)	4	4	4	4	4
Chrome baths* (technical)	1	3	3	1	1
Chromosulphuric acid	4	4	4	4	4
Cresol solution	3	3	4	4	4
Diesel oil	1	1	3	1	1
Fertilizer salts	1	1	1	1	1
Fixing salt	1	1	1	1	1
Floor wax	1	3	3	1	1
Formalin	1	3	3	1	1
Fuel oils*	1	1	3	1	1
Furniture polish*	1	3	3	1	1
Gypsum	1	1	1	1	1
Ink*	1	1	1	1	1
Linseed oil	1	3	1	1	1
Litex (styrene)	4	4	4	4	4
Mineral oils (non-aromatic)	1	1	1	1	1
Moth balls	3	4	3	3	3
Diesel oil*	1	1	3	1	1
Petrol (gasoline) DIN51635	1	3	3	1	1
Petrol, regular	1	3	3	1	1
Petrol, super	3	4	3	1	3
Motor oils*	1	1	1	1	1
Oil no. 3 (ASTM)	1	3	1	1	1
Oleum	4	4	4	4	4
Paraffin	1	1	1	1	1
Paraffin oil	1	1	1	1	1
Petroleum	1	3	3	1	1
Petroleum ether	1	3	4	1	1
Photographic developer	1	1	1	1	1

**Bearings and Lubrication:**

All bearings on the 2200 & 2700 Series conveyor are sealed and lubricated for life. No grease zerk is available and no greasing over the life of the product is required.

All gearmotors used on the 2200 & 2700 series conveyor are sealed and may be mounted in any position. Changing gear oil lubrication may be needed over the life of the gearbox. Please check the appropriate gearmotor manual for instructions.

**Support Stand Locations:**

Support Stand Locations		
Symbol	Description	Value, mm (inches)
A*	Maximum distance back at drive end	457 (18)
B	Maximum distance back at idler end	610 (24)
C	Maximum distance between supports	2743 (96)
D**	Maximum distance away from frame split	600 (12)

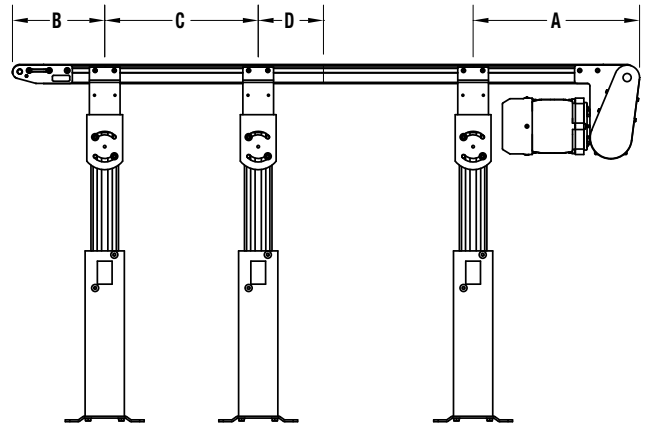

\*Note: For heavy load mount packages stand location must be mounted directly under gearmotor.  
 \*\*Note: Mounting offset frame split requires tie kit 206519

**Conveyor Drive Shaft Tolerances:**

2200 Belted & Modular Belt End Drive:

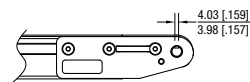
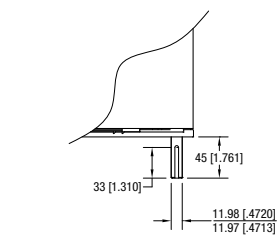

2200 Center Drive:

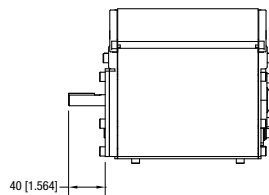
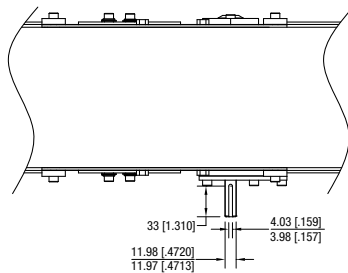

2700 Belted End Drive:

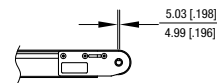
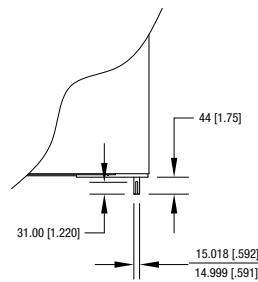

2700 Mid Drive:

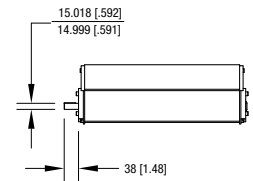
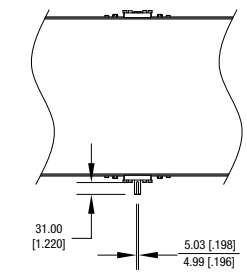

## Conveyor Noise Level (Decibel Ratings)

The actual noise level generated by the conveyor depends on several factors; the installation configuration, the product running on the conveyor, the surrounding equipment, the conveyor options and belt speed. The noise level generated by the conveyor is typically less than the general noise level of factory equipment.

Generally a higher belt speed will result in a higher noise level. In addition modular belt conveyors will run slightly louder than belted conveyors. The following charts provide basic decibel ratings for a typical conveyor arrangements.

### Belted Conveyors:

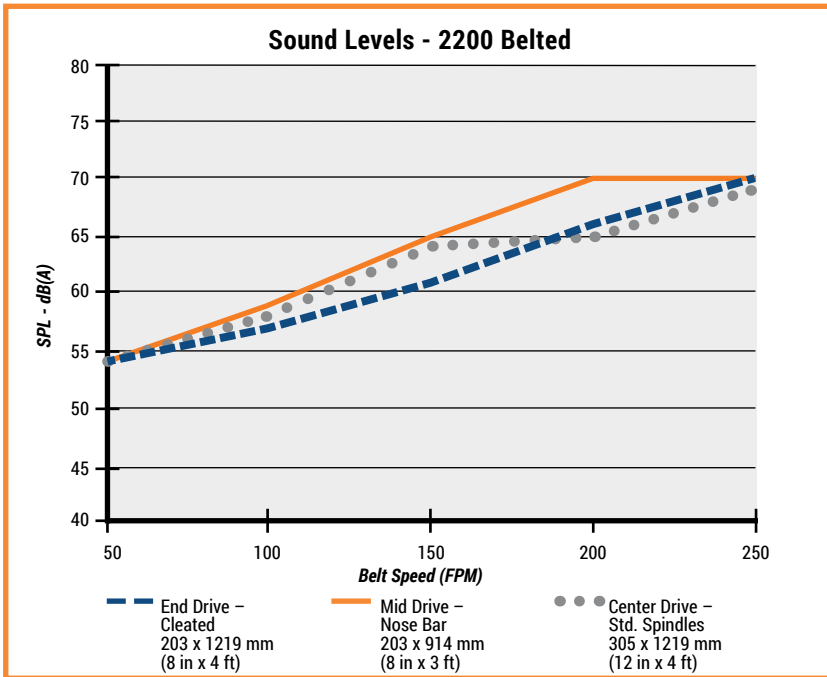

### Modular Belt Conveyors:

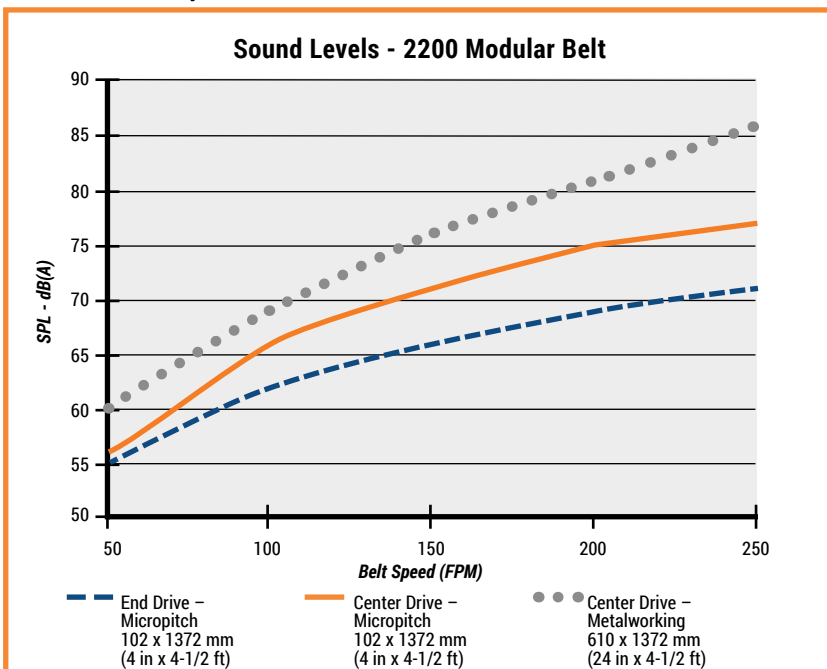

### Maximum Load Capacity

The following Load Capacity Charts **do not** take into account the conveyor configuration, length or gearmotor selection. Your specific conveyor may not be capable of the maximum load condition. Please confirm your maximum load per application with the Dorner DTools program at [www.dornerconveyors.com](http://www.dornerconveyors.com).

All load capacities shown are non-accumulated evenly distributed loads.

2200 Series End Drive Belted Conveyor		
Belt Width	Direction 1, Pulling the Belt	Direction 2 Needs to be 1/3 of Direction 1
51 (2 in) wide	14 kg (30 lbs)	4.54 kg (10 lbs)
76 (3 in) wide	16 kg (35 lbs)	5.44 kg (12 lbs)
102 (4 in) wide	19 kg (42 lbs)	6.35 kg (14 lbs)
127 (5 in) wide	23 kg (50 lbs)	7.66 kg (17 lbs)
152 (6 in) wide	27 kg (60 lbs)	9 kg (19 lbs)
203 (8 in) wide	32 kg (70 lbs)	10.66 kg (23 lbs)
254 to 610 mm (10 to 24 in) wide	36 kg (80 lbs)	12 kg (26 lbs)

2200 Series Belted Center Drive Conveyor		
Belt Width	Direction 1, Pulling the Belt	Direction 2, Pushing the Belt
51 (2 in) wide	18 kg (40 lbs)	6 kg (13 lbs)
76 (3 in) wide	23 kg (50 lbs)	8 kg (17 lbs)
102 (4 in) wide	27 kg (60 lbs)	9 kg (20 lbs)
127 (5 in) wide	34 (75 lbs)	11 kg (25 lbs)
152 (6 in) wide	41 kg (90 lbs)	14 kg (30 lbs)
203 (8 in) wide	48 kg (105 lbs)	16 kg (35 lbs)
254 to 610 mm (10 to 24 in) wide	54 kg (120 lbs)	18 kg (40 lbs)

2200 Series Mid Drive Belted Conveyor	
Belt Width	Either Direction
51 (2 in) wide	14 kg (30 lbs)
76 (3 in) wide	16 kg (35 lbs)
102 (4 in) wide	19 kg (42 lbs)
127 (5 in) wide	23 kg (50 lbs)
152 (6 in) wide	27 kg (60 lbs)
203 (8 in) wide	32 kg (70 lbs)
254 to 610 mm (10 to 24 in) wide	36 kg (80 lbs)

2200 Series Precision Move End and Mid Drive Conveyor	
Belt Width	Either Direction
25 mm (1 in) wide	91 kg (200 lbs)
51 (2 in) wide	91 kg (200 lbs)
76 (3 in) wide	91 kg (200 lbs)
102 (4 in) wide	91 kg (200 lbs)
152 (6 in) wide	91 kg (200 lbs)
203 (8 in) wide	91 kg (200 lbs)
305 (12 in) wide	91 kg (200 lbs)
457 (18 in) wide	91 kg (200 lbs)
610 (24 in) wide	91 kg (200 lbs)

2700 Series End Drive Belted Conveyor		
Belt Width	Direction 1, Pulling the Belt	Direction 2, Pushing the Belt
203 (8 in) wide	45 kg (99 lbs)	15 kg (33 lbs)
254 (10 in) wide	48 kg (106 lbs)	16 kg (35 lbs)
305 (12 in) wide	51 kg (112 lbs)	17 kg (37 lbs)
356 (14 in) wide	54 kg (119 lbs)	18 kg (40 lbs)
406 (16 in) wide	57 kg (125 lbs)	19 kg (42 lbs)
457 (18 in) wide	60 kg (132 lbs)	20 kg (44 lbs)
508 (20 in) wide	63 kg (139 lbs)	21 kg (46 lbs)
559 (22 in) wide	66 kg (145 lbs)	22 kg (48 lbs)
610 to 914 mm (24 to 36 in) wide	68 kg (150 lbs)	23 kg (51 lbs)

2700 Series Mid Drive Belted Conveyor	
Belt Width	Direction 1, Pulling the Belt
203 (8 in) wide	45 kg (99 lbs)
254 (10 in) wide	48 kg (106 lbs)
305 (12 in) wide	51 kg (112 lbs)
356 (14 in) wide	54 kg (119 lbs)
406 (16 in) wide	57 kg (125 lbs)
457 (18 in) wide	60 kg (132 lbs)
508 (20 in) wide	63 kg (139 lbs)
559 (22 in) wide	66 kg (145 lbs)
610 to 914 mm (24 to 36 in) wide	68 kg (150 lbs)

2200 Series Modular Belt End and Center Drive Conveyor	
Belt Width	Direction 1, Pulling the Belt
76 (3 in) wide	36 kg (80 lbs)
102 (4 in) wide	36 kg (80 lbs)
152 (6 in) wide	45 kg (100 lbs)
203 (8 in) wide	45 kg (100 lbs)
305 (12 in) wide	68 kg (150 lbs)
457 (18 in) wide	68 kg (150 lbs)
610 (24 in) wide	68 kg (150 lbs)

## No Load Torque

No load torque is the amount of torque required to turn an empty conveyor. The torque value varies by conveyor length and configuration. The following charts provide basic values for an average length conveyor. Your specific conveyor may not have a higher value. Please confirm your no load torque and maximum load per application with the Dorner DTools program at [www.dornerconveyors.com](http://www.dornerconveyors.com).

### Belted Conveyor

2200 Series Belted Conveyor No Load Torque			
Belt Width mm (in)	End Drive Nm (in-lbs)	Mid Drive Nm (in-lbs)	Center Drive Nm (in-lbs)
44 (1.75)	0.5 (4)	0.8 (7)	1 (9)
70 (2.75)	0.6 (5)	0.9 (8)	1.1 (10)
95 (3.75)	0.7 (6)	1 (9)	1.2 (11)
127 (5)	0.8 (7)	1.1 (10)	1.4 (12)
152 (6)	0.9 (8)	1.4 (12)	1.7 (15)
203 (8)	1.1 (10)	1.7 (15)	2.3 (20)
254 (10)	1.4 (12)	2 (18)	2.6 (23)
305 (12)	1.6 (14)	2.3 (20)	2.8 (25)
356 (14)	1.7 (15)	2.4 (21)	3.1 (27)
406 (16)	1.8 (16)	2.5 (22)	3.2 (28)
457 (18)	1.9 (17)	2.7 (24)	3.4 (30)
508 (20)	2 (18)	2.8 (25)	3.6 (32)
559 (22)	2.1 (19)	2.9 (26)	3.7 (33)
610 (24)	2.3 (20)	3.2 (28)	4 (35)

2700 Series Belted Conveyor No Load Torque		
Belt Width mm (in)	End Drive Nm (in-lbs)	Mid Drive Nm (in-lbs)
203 (8)	0.68 (6)	1.02 (9)
254 (10)	0.85 (7.5)	1.19 (10.5)
305 (12)	1.02 (9)	1.36 (12)
356 (14)	1.19 (10.5)	1.53 (13.5)
406 (16)	1.36 (12)	1.69 (15)
457 (18)	1.53 (13.5)	1.86 (16.5)
508 (20)	1.69 (15)	2.03 (18)
559 (22)	1.86 (16.5)	2.2 (19.5)
610 (24)	2.03 (18)	2.37 (21)
660 (26)	2.2 (19.5)	2.54 (22.5)
711 (28)	2.37 (21)	2.71 (24)
762 (30)	2.54 (22.5)	2.88 (25.5)
813 (32)	2.71 (24)	3.05 (27)
864 (34)	2.88 (25.5)	3.22 (28.5)
914 (36)	3.05 (27)	3.39 (30)

### Modular Belt Conveyor:

The no load torque on modular belt conveyors is dependent on the conveyor length and width. Use the following formula to determine no load torque. Where:

Metric Units:

L = Conveyor Length (mm); W = Conveyor Width (mm)

Micropitch no load torque (Nm) =  $(L/1000) \times 2 \times (W/1000) \times (6.36 \text{ kg/sq m}) \times (0.3 \text{ COF}) \times (7.87 \text{ mm pitch}/1000) \times (9.81 \text{ N/Kg})$

Metalworking no load torque (Nm) =  $(L/1000) \times 2 \times (W/1000) \times (6.36 \text{ kg/sq m}) \times (0.3 \text{ COF}) \times (14.98 \text{ mm pitch}/1000) \times (9.81 \text{ N/Kg})$

Example: 2200 Series Modular Belt 203 mm wide x 3048 mm long.

Micropitch no load torque (Nm) =  $(3048/1000) \times 2 \times (203/1000) \times (6.36 \text{ kg/sq m}) \times (0.3 \text{ COF}) \times (7.87 \text{ mm pitch}/1000) \times (9.81 \text{ N/Kg}) = 0.18 \text{ Nm}$

Metalworking no load torque (Nm) =  $(3048/1000) \times 2 \times (203/1000) \times (6.36 \text{ kg/sq m}) \times (0.3 \text{ COF}) \times (14.98 \text{ mm pitch}/1000) \times (9.81 \text{ N/Kg}) = 0.35 \text{ Nm}$

Imperial Units:

L = Conveyor Length (ft); W = Conveyor Width (in)

Micropitch no load torque (in-lbs) =  $(L) \times 2 \times (W/12) \times 1.3 \text{ lb/sq ft} \times (0.3 \text{ COF}) \times (0.31 \text{ in pitch}) \times 0.858$

Metalworking no load torque (in-lbs) =  $(L) \times 2 \times (W/12) \times 1.3 \text{ lb/sq ft} \times (0.3 \text{ COF}) \times (0.59 \text{ in pitch}) \times 0.94$

Example: 2200 Series Modular Belt 8 in wide x 10 ft long

Micropitch no load torque (in-lbs) =  $(10) \times 2 \times (8/12) \times 1.3 \text{ lb/sq ft} \times (0.3 \text{ COF}) \times (0.31 \text{ in pitch}) \times 0.858 = 1.38$

Metalworking no load torque (in-lbs) =  $(10) \times 2 \times (8/12) \times 1.3 \text{ lb/sq ft} \times (0.3 \text{ COF}) \times (0.59 \text{ in pitch}) \times 0.94 = 2.88$

### Belting and Coefficient of Friction

The coefficient of friction is used to determine the load a conveyor can carry. It effects a conveyor in two ways: the friction that exists between the conveyor belt and the bed surface, and if accumulating product, the friction that exists between the conveyor top surface and the product.

#### Coefficient of Friction, between the bottom of the conveyor belt and bed surface:

Product	Surfaces	Application Condition	Coefficient of Friction
2200 & 2700 Series Belted	Impregnated polyester fabric to anodized aluminum bed plate	Dry	0.33
2200 Series Modular Belt	Acetal modular belt to UHMW wear strips	Dry	0.30

#### Coefficient of Friction, between the top surface of conveyor belt and product:

2200 & 2700 Series Belted		
The following table provides the coefficient of friction between steel product and various belt top surfaces. All factors below are assuming dry conditions.		
Belt Number	Top Surface Material and Type	Coefficient of Friction
01, 54, 58, 68, 73, 81	Smooth hard urethane	0.40
02, 59, 60, 61, 66, 72, 76, 79	Smooth medium urethane	0.50
03, 19, 55, 69, 75, 77, 78, 80	Glossy soft urethane	>1.0, do not accumulate
05, 06, 50, 53, 63	Impregnated polyester fabric	0.20
08, 18, 64	PVC, Very High friction	>1.0, do not accumulate

2200 Series Modular Belt	
The following table provides the coefficient of friction between acetal modular belt and various products. All factors below are assuming dry conditions.	
Product Being Accumulated	Typical Coefficient of Friction
Steel	0.25
Glass	0.20
Aluminum	0.25
Plastic	0.25
Wood	0.30
Paper and Cardboard	0.30

## Calculating Conveyor Belt Speed

### 2200 & 2700 Series Belted Conveyors:

To calculate the conveyor belt speed you need to know the following factors:

- Drive roller diameter
  - 32 mm (1.25 in) for 2200 end, mid and center drives
  - 60 mm (2.4 in) for 2700 end and mid drives
- Number of teeth of pulley located at drive roller (if equipped)
- Number of teeth of pulley located at gearmotor (if equipped)
- RPM of gearmotor

$$\text{Belt Speed (ft/min)} = (\text{Drive roller diameter}/12) * (3.14) * (\text{RPM of gearmotor}) * \frac{(\text{Teeth at gearmotor})}{(\text{Teeth at drive roller})}$$

Example:

2200 Series End Drive with a Bottom mount with a 28 tooth pulley located at the drive roller and a 44 tooth pulley located on the gearmotor. The gearmotor is a 20:1 ratio with 86 rpm output.

$$\text{Belt Speed (ft/min)} = (1.25/12) * (3.14) * (86) * (44/28)$$

$$\text{Belt speed (ft/min)} = 44.2 \text{ ft/min}$$

### 2200 Series Modular Belt Conveyors:

To calculate the conveyor belt speed you need to know the following factors:

- Drive sprocket pitch diameter
  - 43.4 mm (1.71 in) for Belts 01 and 02
  - 47.8 mm (1.88 in) for Belts 30, 31, 32, 40, 41 and 42
- Number of teeth of pulley located at drive roller (if equipped)
- Number of teeth of pulley located at gearmotor (if equipped)
- RPM of gearmotor

$$\text{Belt Speed (ft/min)} = (\text{Drive pitch diameter}/12) * (3.14) * (\text{RPM of gearmotor}) * \frac{(\text{Teeth at gearmotor})}{(\text{Teeth at drive roller})}$$

Example:

2200 Series Straight Modular Belt Conveyor with a Bottom mount with a 28 tooth pulley located at the drive roller and a 44 tooth pulley located on the gearmotor. The gearmotor is a 20:1 ratio with 86 rpm output. Belt type is 30.

$$\text{Belt Speed (ft/min)} = (1.88/12) * (3.14) * (86) * (44/28)$$

$$\text{Belt speed (ft/min)} = 66 \text{ ft/min}$$

### Calculating Conveyor Load Capacity

There are several factor that effect the overall conveyor load of the 2200 & 2700 Series conveyor. These include:

- Conveyor size and configuration
- Conveyor speed
- Application temperature
- Product Accumulation
- Number of starts and stops per hour

Located online at [www.dornerconveyors.com](http://www.dornerconveyors.com) is the Dorner conveyor configuration tool, DTools. This tool allows you to configure your conveyor layout and determine the maximum load capacity for the conveyor. It is suggested that this program be used to calculate the conveyor load as the calculation is quite complicated. This configuration program however does not take into account temperature, dirty conditions, and conveyor starts and stops. If these conditions are part of your application please use the load reducing factors as shown below.

$$\text{Maximum Load} = (\text{Load from DTools})(\text{Temperature Factor})(\text{Start/Stop Factor})$$

Temperature Factor		
Ambient temperature can negatively affect the capacity of the conveyor.		
Temperature F	Temperature C	Temperature Factor
-4	-20	1.0
32	0	1.0
68	20	1.0
104	40	0.9
140	60	0.8

Start / Stop Factor	
Frequent Start / Stops of the conveyor can negatively affect the capacity of the conveyor. All start / stop applications must use a soft start mechanism such as a Frequency Inverter with a 1 second acceleration cycle.	
Application Condition	Start / Stop Factor
Continuous Run or 1 start/stop per hour	1.0
Maximum 10 starts/stop per hour	0.83
Maximum 30 starts/stop per hour	0.70
Greater than 30 starts/stop per hour	0.62

## Servo Motor / Control Torque Curves

### Motor Only with 115V Control

Rated Speed = 1500 RPM

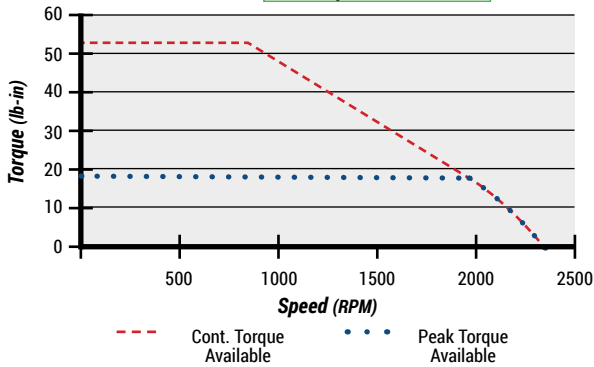

### Motor Only with 230V Control

Rated Speed = 2,500 RPM

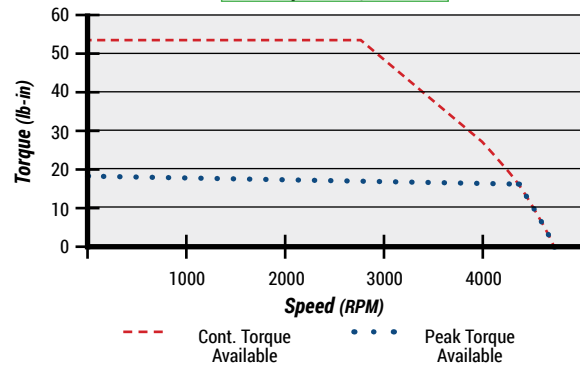

## Servo Performance Data

### Accuracy:

- 2200 Series: Index consistency =  $\pm 0.040$  in

### Maximum Speed (Velocity):

- 2200 Series: 300 ft/min = 60 in/sec

### Maximum Acceleration Rate: 200 in/sec/sec

### Maximum Deceleration Rate: 400 in/sec/sec

### Maximum Index Rate: 100 indexes per minute (0.6 sec total cycle; 0.2 sec accel, 0.2 sec dwell, 0.2 sec decel)

### Minimum Distance for Slow Down / Deceleration

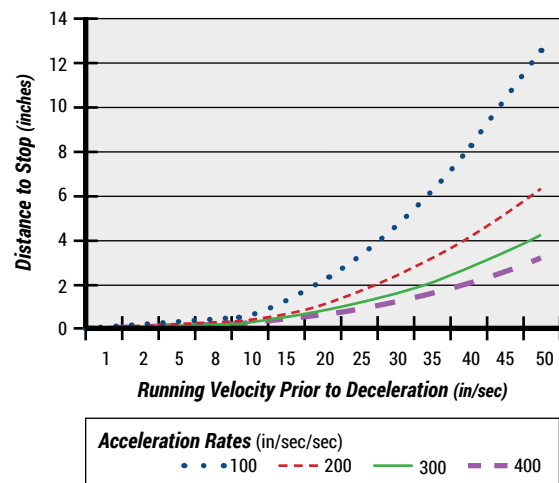

### Minimum Distance for Speed Up / Acceleration

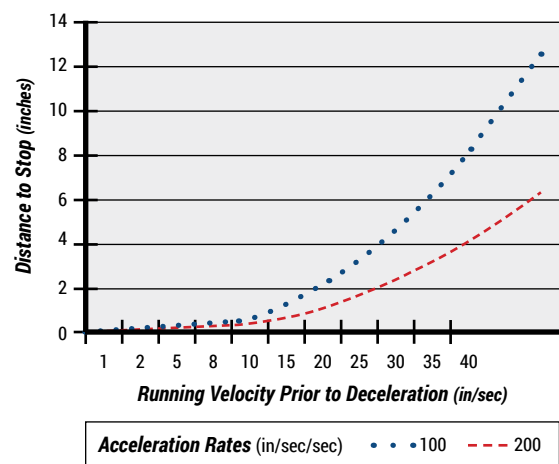

Due to the wide variety of conveyor and stand options along with possible configurations, stability of the final setup is the responsibility of the end user.

## 2200 & 2700 Series Conveyors are best for:

- Small to Medium Part Handling
- Precision Part Movement
- Positioning
- Transfers
- Part Incline/Decline Routing (Z Frames)
- Automated and Manual Assembly
- Accumulation

## Sizes & Measurements

- 25 - 914 mm (1 - 36 in) widths
- 457 - 9144 mm (18 in - 30 ft) lengths

## Loads & Speeds

- Up to 68 kg (150 lbs)
- Up to 122 mpm (400 fpm)



## Conveyor Configurations



**Straight**



**2700 Series**



**Z-Frame**



**Horizontal to Incline**



**Nose-Over**



**Industrial**



**Flexible Chain**



**Pallet Systems**



**Sanitary Stainless Steel**

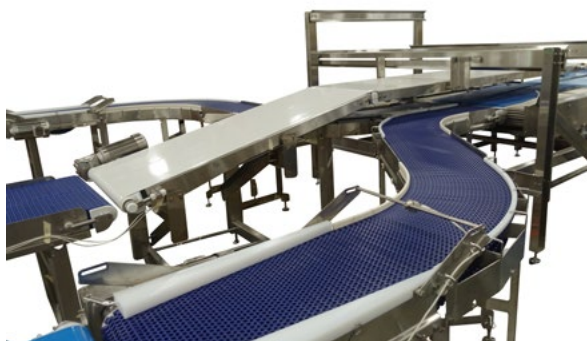

**Engineered Solutions Group**

Custom engineered solutions for almost any application.



**CAD Configurator Tool**

Industry leading tool! Configure your own custom conveyor in minutes.

# TRANSFORMING CONVEYOR AUTOMATION

## Contact Dorner

**United States**  
+1-262-367-7600

**Canada**  
+1-289-208-7306

**Mexico**  
+52.33.30037400

**Germany**  
+49 (0) 2461/93767-0

**France**  
+33 (0)1 84 73 24 27

**Malaysia**  
+604-626-2948



By Columbus McKinnon

[DORNERCONVEYORS.COM](http://DORNERCONVEYORS.COM)



MAGNETEK

montratec

CONVEYANCE SOLUTIONS

© Dorner Mfg. Corp. 2026. All Rights Reserved.

851-803 0526