

ENGINEERING MANUAL

Fast & Simple to Use
Online Configurator

Innovative Timing Belt
Conveyor Design

Industry Best
Pallet Transfer System

Stable & Durable
Construction



DualMove

High Performance Dual Strand
Timing Belt Pallet System

DORNER[®]
By Columbus McKinnon

Innovative Modules

- Lift and Locate:
 - Standard vertical lift stop to ensure repeatable accuracy
 - Lift capacity roughly 2x pallet capacity at 60 psi
 - Accuracy of ± 0.13 mm (0.005 in)
- Lift and Rotate:
 - Pneumatic lift from center of conveyor
 - Pneumatic rotation with adjustable positioning
 - Rotation angle: 90 to 180 degrees adjustable
 - Includes cushioned lift stroke
- Lift and Transfer:
 - Changes product leading edge and allows for tight parallel assembly lines
 - Uses 24VDC motors with digital on/off signals
 - Load capacities matches pallet sizes, up to 45 kgs (100 lbs)

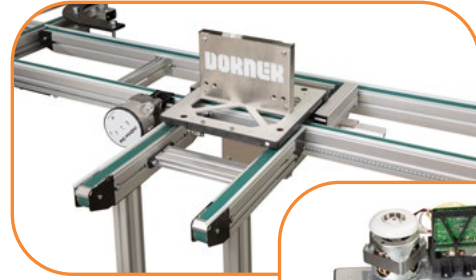

Lift & Transfer

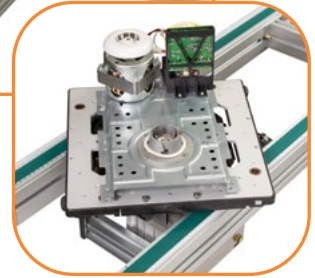

Lift & Rotate

Simple Powered Corner Modules

- 90/180 Degree Corners:
 - Uses pin tracking in pallet
 - Maintains product orientation through the turn
 - Includes 24VDC drive mechanism to drive the pallet around the corner
- 90 Degree Corner and Merge:
 - Uses pin tracking in pallet
 - Inside guide is mounted to pneumatic cylinders to transfer pallet around corner
 - Straight guide with pneumatic cylinder is mounted across perpendicular conveyor to guide pallets straight through the merge area
 - Includes 24VDC drive mechanism to drive the pallet around the corner



90 Degree Corner



180 Degree Corner

Accurate Pin Tracking System

- Simple and cost effective method of tracking pallets through turns
- Used on 90 Degree Corner and 90 Degree Corner & Merge Modules



The Benefits of a DORNER DualMove Pallet System

Innovative Offering

- T10 timing belt provides maximum load capacity for conveyors
- Quick belt change without the need to remove conveyor from system
- Pin Tracking System provides cost effective pallet traffic management

Delivers Fast

- DORNER sets the industry standard for rapid delivery
- Conveyors and automation modules available in 20 days or less

Time Saving

- DORNER's online configurator engineers simple to complex configurations in minutes.
- The industry leading tool delivers a complete 3D Assembly model for instant validation of fit

**CONVEYOR
FEATURES**
PAGES 4-5

**EXAMPLE
LAYOUTS**
PAGES 6-7

**CORNERS
& TURNS**
PAGES 24-29

**PALLET
STOPS**
PAGES 32-35

**TURN &
MERGE**
PAGES 30-31

BELTS
PAGE 37

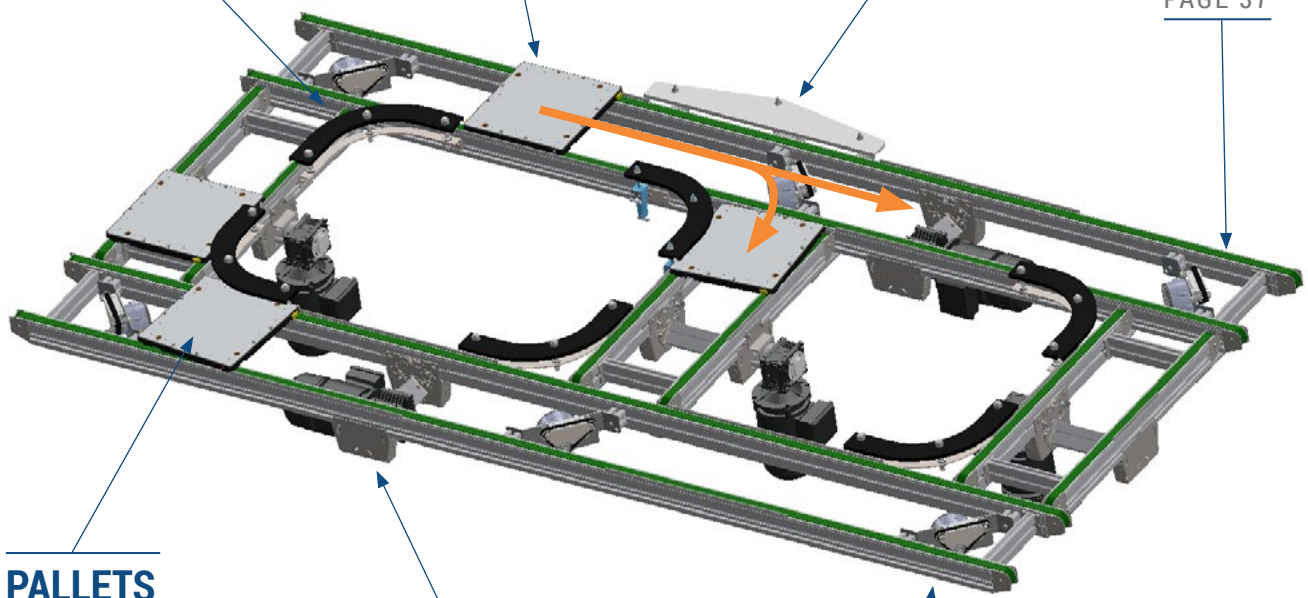

PALLETS
PAGES 12-13

**MOTORS &
CONTROLLERS**
PAGES 38-42

CONVEYORS
PAGES 8-11

**LIFT &
ROTATE**
PAGES 22-23

**LIFT &
TRANSFER**
PAGES 19-21

**LIFT &
LOCATE**
PAGES 14-18

**SUPPORT
STANDS**
PAGE 43

**ENGINEERED
SOLUTIONS**
PAGES 36

ACCESSORIES
PAGES 44-47



**TECHNICAL DATA &
CALCULATIONS**
PAGES 48-59



INNOVATIVE CORNERS

Cost effective method to keep product leading edge and move pallet around corners. Utilizes innovative pallet pin tracking system, available in heavy or standard load and 90 or 180 degrees.

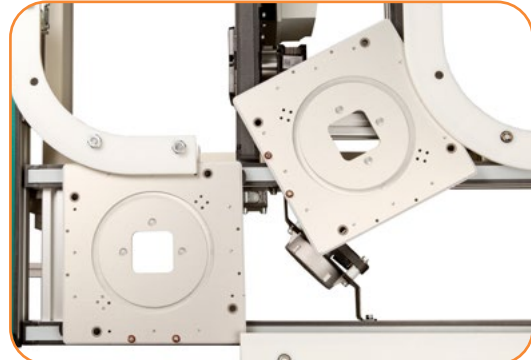

MERGES & BYPASSES

Simple merge and bypass modules utilize the pin tracking system, with additional air cylinders and stops creating a cost effective way to control pallet traffic within a system.

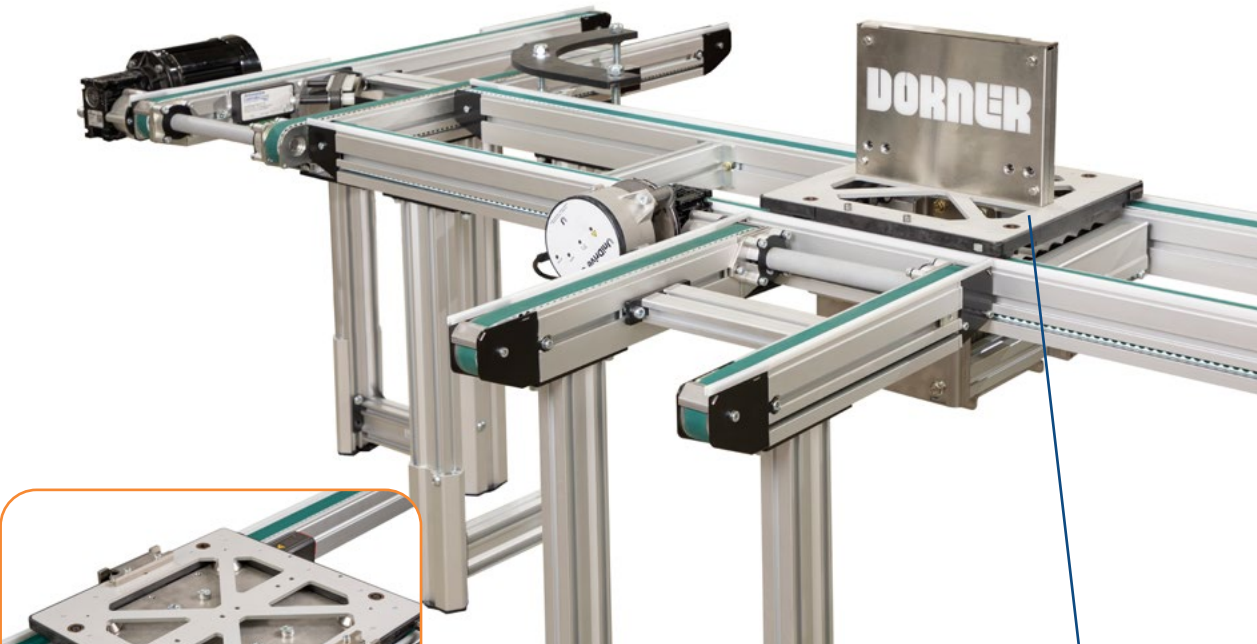

LIFT AND LOCATES

Two distinct standard platforms to choose from depending on cost and accuracy needs. Standard lift modules are accurate to +/- 0.13 mm (0.005 in), and smaller low profile modules up to +/- 0.38 (0.015 in). Utilizing tapered pin on lift module and precision bushings on work pallet. Lift capacity exceeds pallet capacity by about 2x allowing pressing operations to be done directly on the module without additional supports.



LIFT AND ROTATE

Field configurable rotate units allows the product to change orientation. Air cylinders provide the actuation of the units, and breakaway magnetically couple plate supports the pallet as it rotates.



LIFT AND TRANSFERS

Transfer units utilize a 24VDC digitally controlled gearmotor for easy controls integration. The combination of small motor and air cylinder provides a small profile under the conveyor allowing more flexibility in system design.

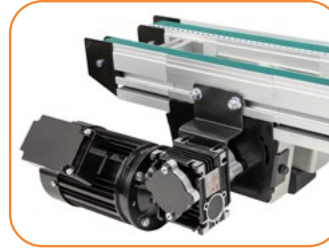
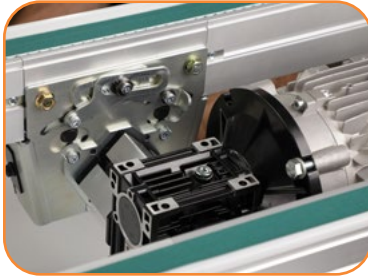

CONVEYOR CONFIGURATIONS

Motor can be placed in a variety of locations providing best fit into the application. Mid-Drives systems can be built up to 7.5 meters (25 ft) long as standard or longer for custom systems, with motor options both inside or outside conveyor frame. End-Drive units are bi-directional and is a cost effective configuration for conveyors shorter than 3.8 meters (12.5 ft). A 24 volts brushless DC motor options provides a safe low voltage configuration with a high torque output, and compatible with several industry available DC controllers.

CONVEYOR CONSTRUCTION

Aluminum profile provides a light weight rigid conveyor with Universal T-Slots accepting a variety of industry available T-Nuts & T-Bolts. Making system integration easy by allowing sensors and system structure to bolt on the conveyor. Field removable pallet guide allows flexibility during installation and faster startups. Conveyor drives, pulleys, and tensioning systems are completely built from metal parts and large 2 in bearings to provide a long lasting and robust system.

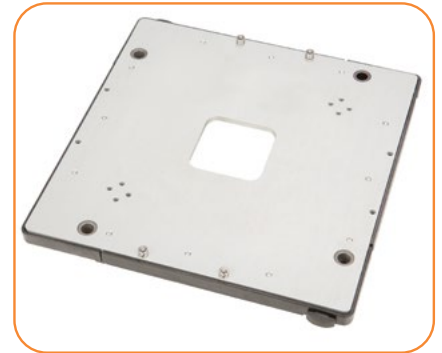
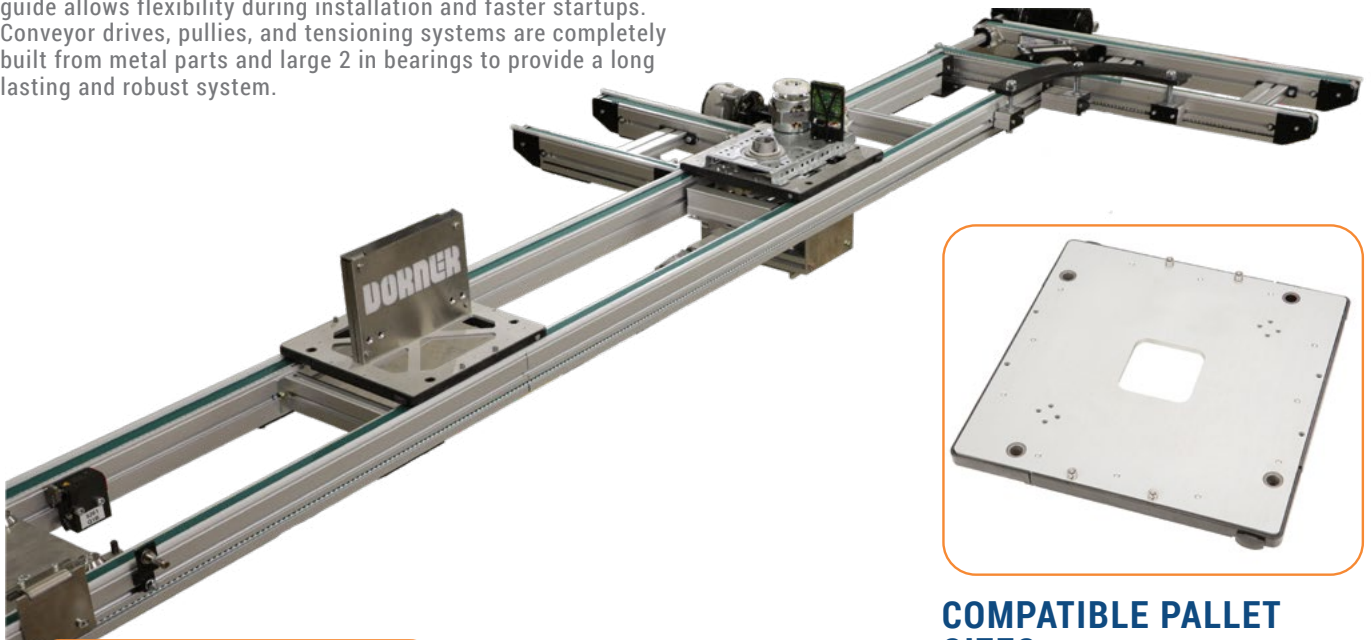

COMPATIBLE PALLET SIZES

Pallets sizes and locational bushings compatible to in industry standard other Dorner pallet systems. A variety of options from fully assembled to kitted parts can be ordered to provide best solution for integration.



QUICK BELT CHANGE

Innovative patent pending belt tensioning systems paired with an optional pinned spliced timing belt provides industry quickest belt change system. The single point tensioning system utilizes a rack & pinion system that can be adjusted with a single tool.

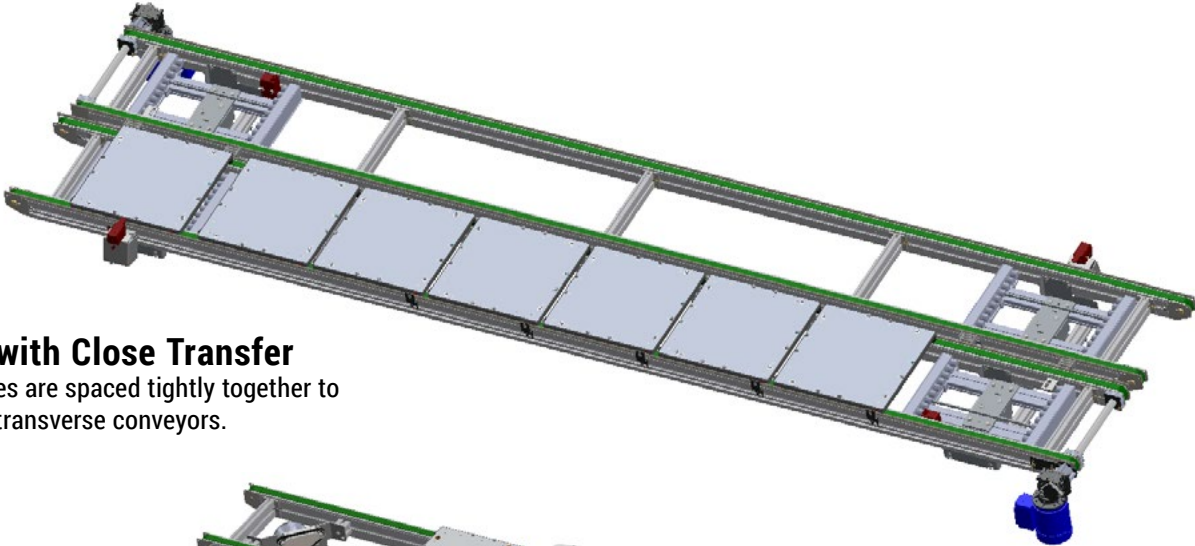

Loop with Close Transfer

Main lines are spaced tightly together to remove transverse conveyors.

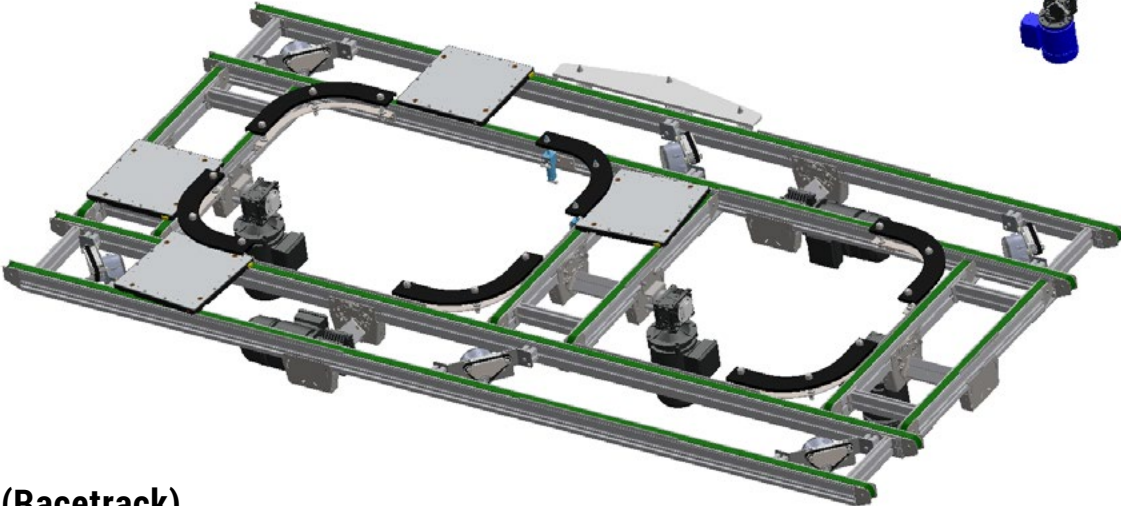

Loop (Racetrack)

Leading edge orientation is maintained using 90 degree corners.

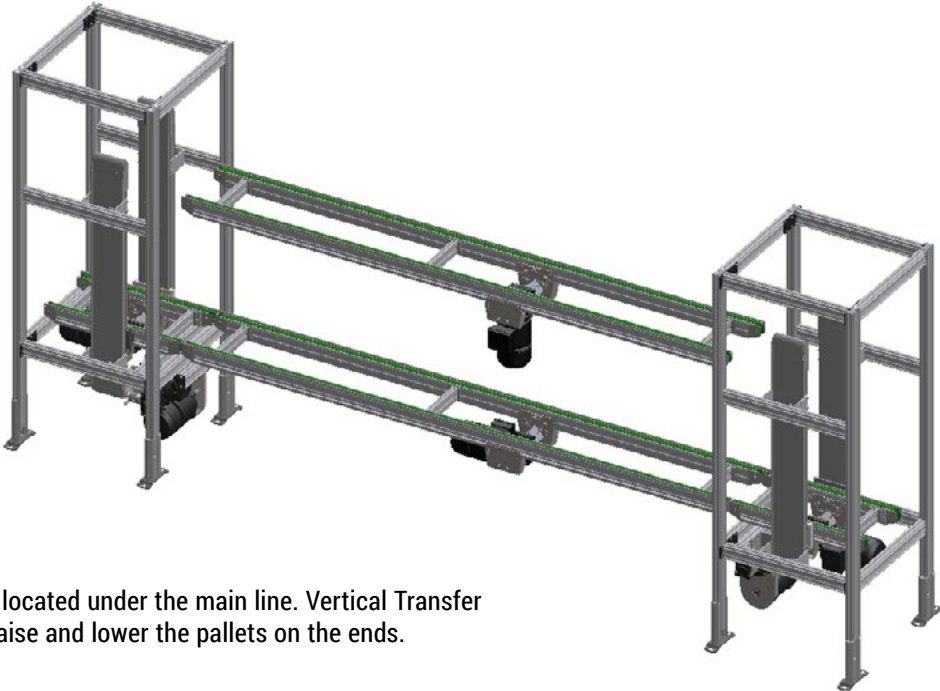

Over Under

The return line is located under the main line. Vertical Transfer Units (Elevator) raise and lower the pallets on the ends.

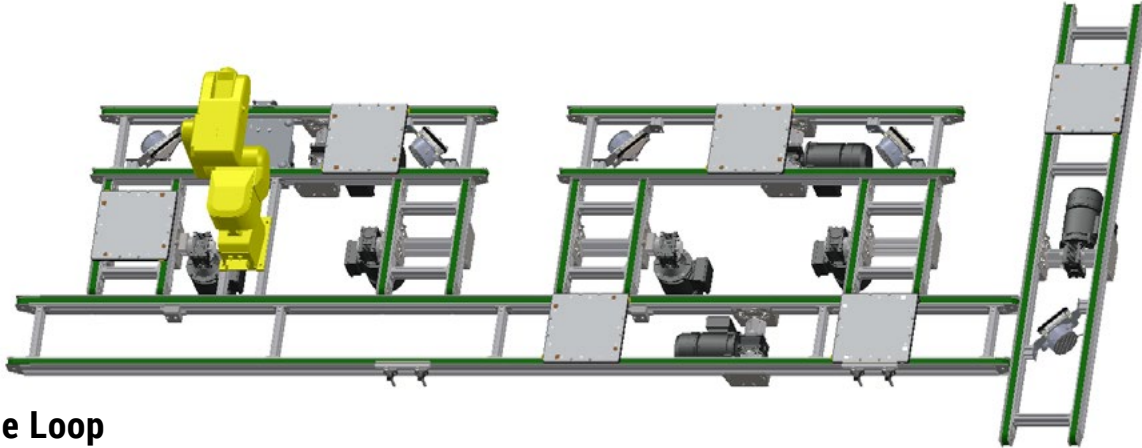

Satellite Loop

Satellite loops provide workstation loops off the main line for operators or machine interface.

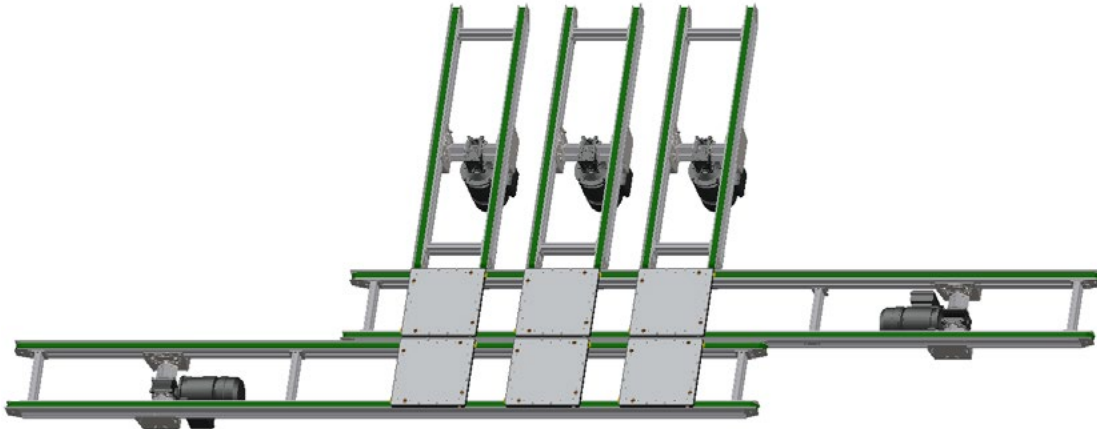

Spur Line

The product flow in this example is from right to left. The pallet travels along the upper main line then transfers into 1 of the 3 parallel operations on the vertical spur lines. When the operation is complete the spur line reverses direction and the pallet transfers over the upper main line onto the bottom main line for finished processing.

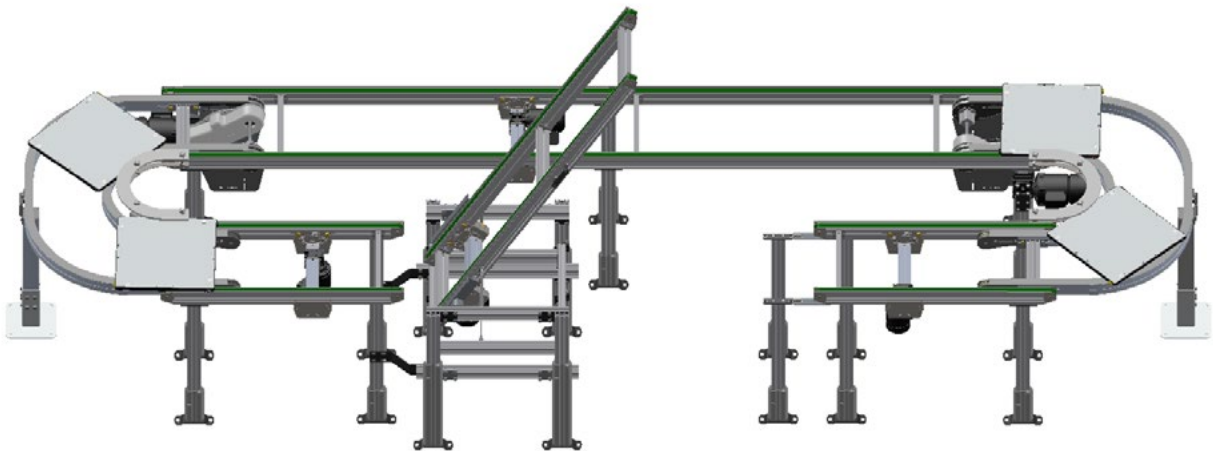

Heavy Load Loop

Tight radius turns maintain leading edge orientation while keeping the main lines closely spaced to reduce the overall footprint. Heavy load corners allow pallet accumulation in the corners.

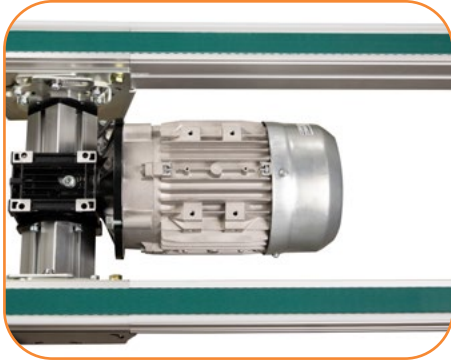

In Frame Motor



Side Drive Motor

Specifications

- 25 mm wide belting
- Overall width:
 - Width is defined by the pallet width
 - Nominal widths (mm) 160, 240, 320, 400, 480, 640, and 800
- Custom widths available in Dtools from 140-800 mm by 5mm increments.
- Lengths: 500 to 7500 mm (20 in to 24.6 ft) long, in 5 mm increments
- Load Capacity: 365 kg (805 lbs) non-accumulating, 185 kg (408 lbs) accumulated
- Belt speeds to 66 m/min (215 ft/min)
- Bi-directional belt at full load capacity
- Belts: T10 timing belts with steel cords
 - Medium Friction, Low Friction, and Static Conductive Low Friction available
- Drive Pulley: T10, 19 tooth, Pitch diameter 60.6 mm (2.386 in)
- 50.8 mm (2.0 in) diameter end rollers
- Mid Drive is available in any location along the conveyor rails starting at 250 mm (10 in) from each end
- Quick belt change design along with single point tensioning mechanism, allows changing of conveyor belt without removal of conveyor or automation devices
- Conveyor T-Slot located on bottom and both sides. Compatible with Dorner 2200 Series and FlexMove® T-Slot hardware along with select industry standard 10 mm slot hardware.

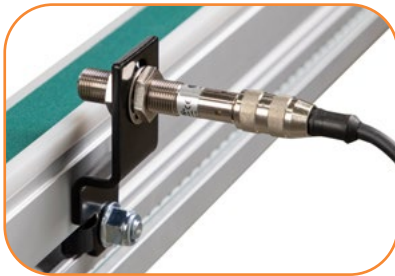

STANDARD FEATURE:
Universal T-Slot
Compatible with Industry
Standard 10 mm hardware



STANDARD FEATURE:
Interchangeable Low Side



STANDARD FEATURE:
Quick belt change
without the removal of
conveyor or accessories

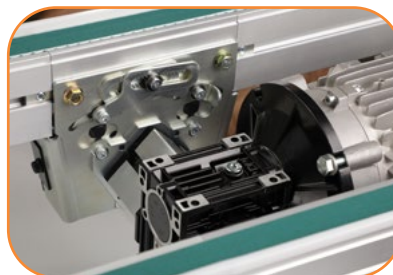

STANDARD FEATURE:
Tensioning Mechanism

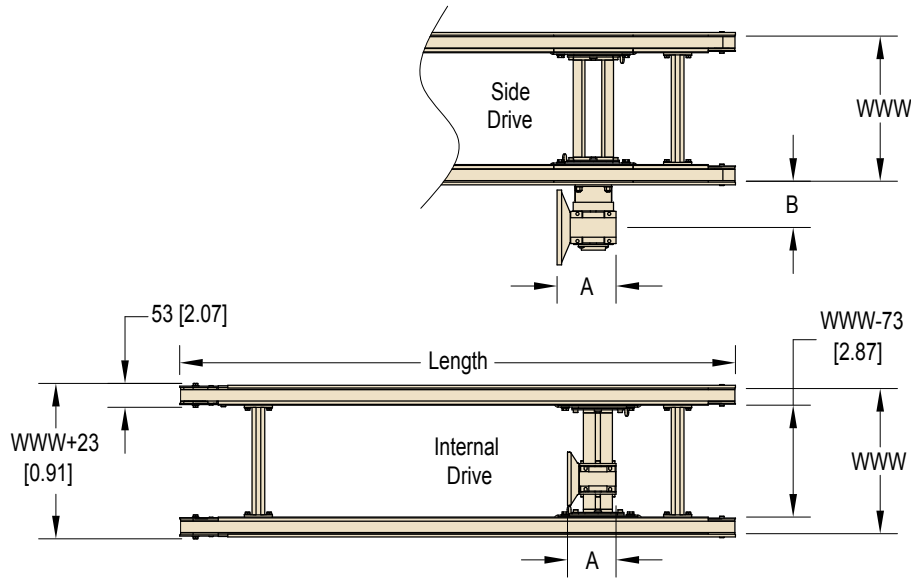

A = 107 [4.23] for Medium Load
 130 [5.12] for Heavy Load
 B = 102 [4.01] for Medium Load
 128 [5.05] for Heavy Load

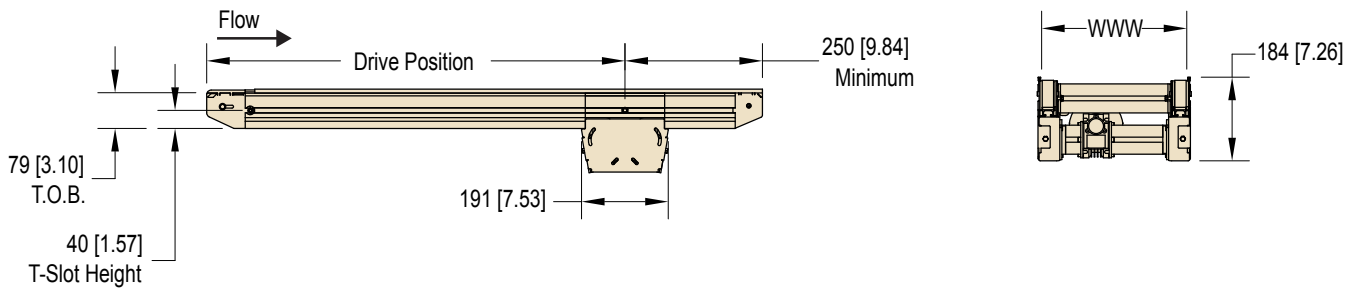

Motor Orientation

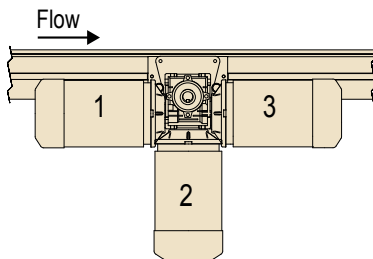

Drive Shaft Position

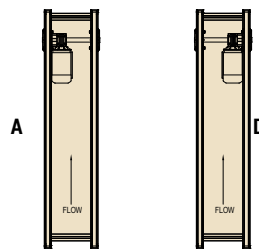

In-Line Conveyor Distance & Tie Brackets

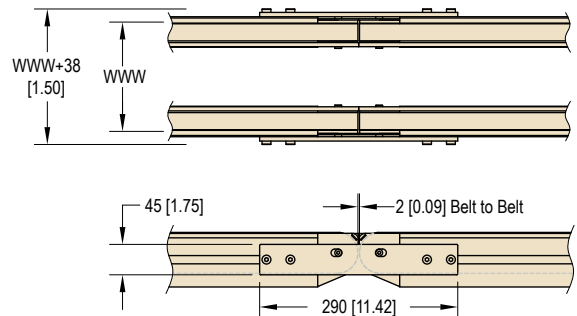

DualMove Series: Dual Strand Conveyor

DS	2Q	M	WWW	-	LLLL	C	M	O	G	A	BB	-	PPPP
Drive Position: PPPP in millimeters from infeed to center of drive shaft = 0250-7250 (5 mm increments) Belt Type: 1D = Low Friction 2D = Med Friction 3D = ESD Low Friction 1P = Low Friction, pin splice 2P = Med Friction, pin splice 3P = ESD Low Friction, pin splice Conveyor Speed: E = 5:1 - 66 m/min (215 fpm) D = 10:1 - 33 m/min (108 fpm) C = 20:1 - 16.5 m/min (54 fpm) B = 40:1 - 8.2 m/min (27 fpm) A = 60:1 - 5.5 m/min (18 fpm) Motor type: M = Medium load E-drive 42CZ head H = Heavy load E-Drive 56C head Motor Orientation: 1 = Horizontal (leading) 2 = Vertical (down) 3 = Horizontal (trailing) Drive Position: A = A Side D = D Side (motor in the center of conveyor for width 320 and lower) Drive type: C = Mid Drive with internal motor mount M = Mid Drive with side motor mount Conveyor Length Reference: LLLL in millimeters 0500 - 7500 (in 5 mm increments) Conveyor Width Reference: WWW in millimeters 140 - 800 (in 5 mm increments) Documentation Language: M = US-English U = Europe English D = German F = French S = Spanish Conveyor Type: Dual Strand Pallet System, 25 mm Belt													

Note: Due to the wide variety of drive setups and applications, point of installation guarding is the responsibility of the end user.

Note: Dimensions = mm (in)

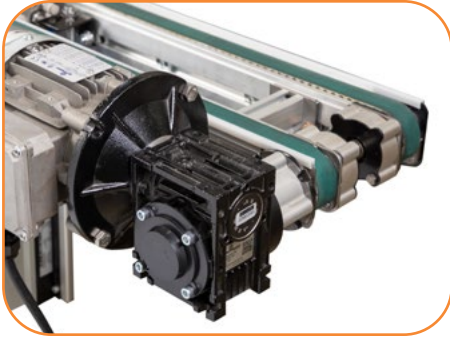

Specifications

- 25 mm wide belting
- Overall width:
 - Width is defined by the pallet width
 - Nominal widths (mm) 160, 240, 320, 400, 480, 640, and 800
- Custom widths available in Dtools from 140-800 mm by 5mm increments.
- Lengths: 300 to 3800 mm (12 in to 12.5ft) long, in 5 mm increments
- Load Capacity: 365 kg (805 lbs) non-accumulating, 185 kg (408 lbs) accumulated
- Belt speeds to 66 m/min (215 ft/min)
- Bi-directional belt at full load capacity
- Belts: T10 timing belts with steel cords
 - Medium Friction, Low Friction, and Static Conductive Low and Medium Friction available
- Drive Pulley: T10, 19 tooth, Pitch diameter 60.6 mm (2.386 in)
- 50.8 mm (2.0 in) diameter end rollers
- Quick belt change design along with single point tensioning mechanism, allows changing of conveyor belt without removal of conveyor or automation devices
- Conveyor T-Slot located on bottom and both sides. Compatible with Dorner 2200 Series and FlexMove® T-Slot hardware along with select industry standard 10 mm slot hardware.

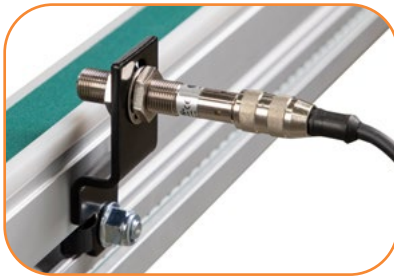

STANDARD FEATURE:
Universal T-Slot
Compatible with Industry
Standard 10 mm hardware



STANDARD FEATURE:
Quick belt change
without the removal of
conveyor or accessories



STANDARD FEATURE:
Tensioning Mechanism

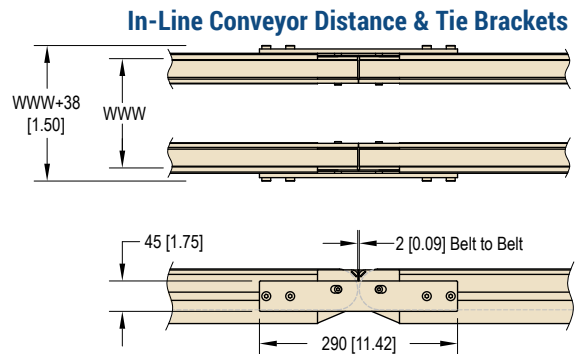
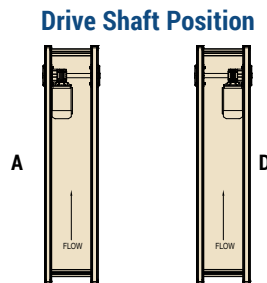
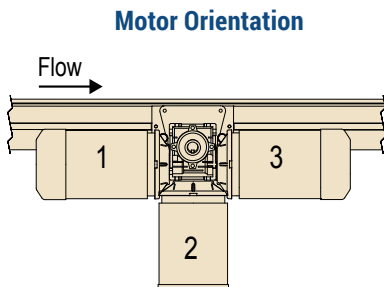
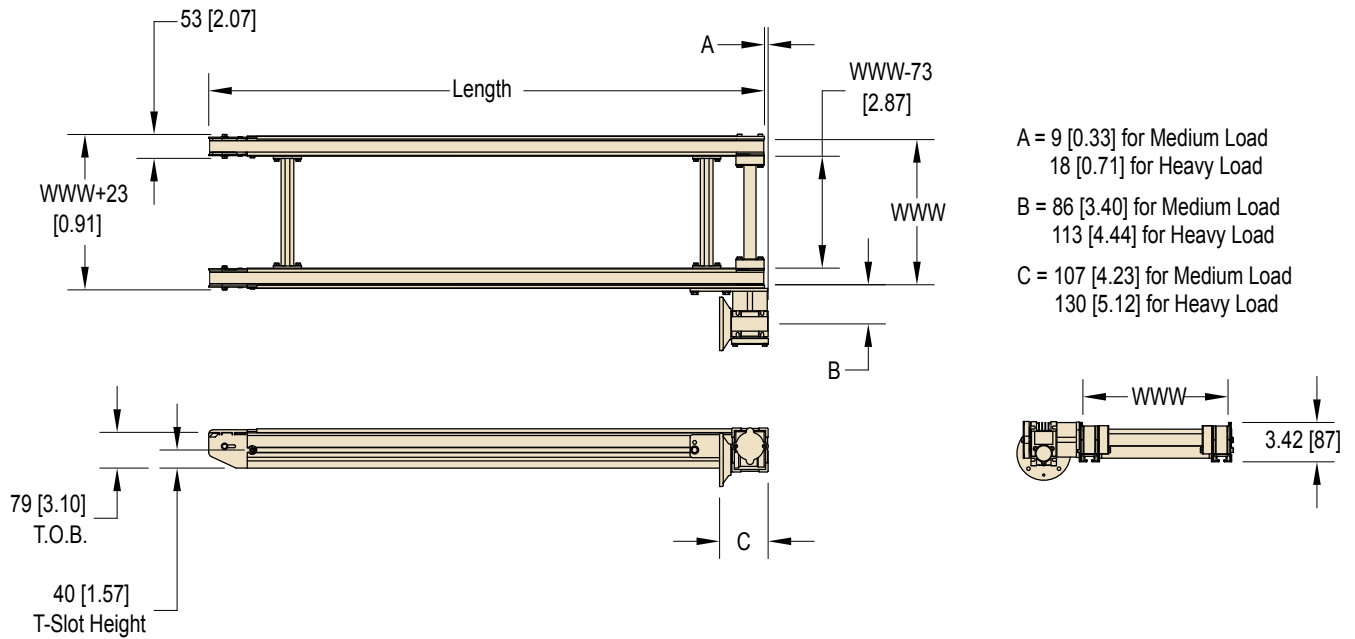

DualMove Series: Dual Strand Conveyor

DS2Q M WWW - L L L L C M O G A B B

- Belt Type: 1D = Low Friction 2D = Med Friction 3D = ESD Low Friction
- 1P = Low Friction, pin splice 2P = Med Friction, pin splice 3P = ESD Low Friction, pin splice
- Conveyor Speed: E = 5:1 - 66 m/min (215 fpm) D = 10:1 - 33 m/min (108 fpm) C = 20:1 - 16.5 m/min (54 fpm)
- B = 40:1 - 8.2 m/min (27 fpm) A = 60:1 - 5.5 m/min (18 fpm)
- Motor type: M = Medium load E-drive 42CZ head H = Heavy load E-Drive 56C head
- Motor Orientation: 1 = Horizontal (leading) 2 = Vertical (down) 3 = Horizontal (trailing)
- Drive Position: A = A Side B = B Side C = C Side D = D Side
- Drive type: E = End Drive conveyor M = Mid Drive with side motor mount
- Conveyor Length Reference: L L L L in millimeters 0300 - 3800 (in 5 mm increments)
- Conveyor Width Reference: WWW in millimeters 140 - 800 (in 5 mm increments)
- Documentation Language: M = US-English U = Europe English D = German F = French S = Spanish
- Conveyor Type: Dual Strand Pallet System, 25 mm Belt

Note: Due to the wide variety of drive setups and applications, point of installation guarding is the responsibility of the end user.

Note: Dimensions = mm (in)

Specifications

- Pallet is dimensionally compatible with industry standards
- Pallet Base:
 - Anodized aluminum tool plate is standard (other materials available, contact factory)
 - Thicknesses of 4.8 to 12.7 mm (3/16 to 1/2 in)
- Pallet Skirt Material: Electrostatic Dissipative HPDE
- Includes (4) hardened bushings for Lift and Locate
- Optional Ball Bearing Pin Tracking used for pallet tracking at corners
- Plated Steel Proximity Sensor pick-up on bottom and side of pallet
- Optional pallet bumpers for noise and impact reduction
- Custom widths available
- Center of gravity of the combined payload should be located in the center third of the pallet



Optional Pallet Bumpers



Optional Ball Bearing Pin Tracking

Total Load Capacity including Pallet, Fixture and Product:

		Pallet Length (mm)						
		160	240	320	400	480	640	800
Width (mm)	160	14kg (30lbs)	18kg (40lbs)					
	240	18kg (40lbs)	23kg (50lbs)	27kg (60lbs)		32kg (70lbs)		
	320		27kg (60lbs)	32kg (70lbs)		32kg (70lbs)		
	400				32kg (70lbs)	36kg (80lbs)		
	480		32kg (70lbs)	32kg (70lbs)	36kg (80lbs)	36kg (80lbs)	45kg (100lbs)	
	640					45kg (100lbs)	45kg (100lbs)	45kg (100lbs)
	800						45kg (100lbs)	45kg (100lbs)

DualMove Series: Pallets

22DS P M WWW - LLL A T P

- Pin Tracking System: 0 = Without Pin Tracking System 1 = Single Side Pin Tracking System
2 = Dual Side Pin Tracking System 4 = 4 Side Pin Tracking System
- Plate Thickness: 3 = 3/16" 4 = 1/4" 6 = 3/8" 8 = 1/2"
- Pallet Options: A = Assembled with aluminum top plate
B = Assembled with aluminum top plate and bumper on two ends
C = Kit only without aluminum top plate
D = Kit only without aluminum top plate, includes bumper on two ends
E = Assembled AL with STD holes
F = Assembled AL with STD holes & Bumpers
- Pallet Length Reference: See table above for standard Lengths
- Pallet Width Reference: See table above for standard Widths
- Documentation Language: M = US-English
- Conveyor Type: P = Pallet

*Note: Pallet bumper cannot be used in applications where pallets slide against each other.

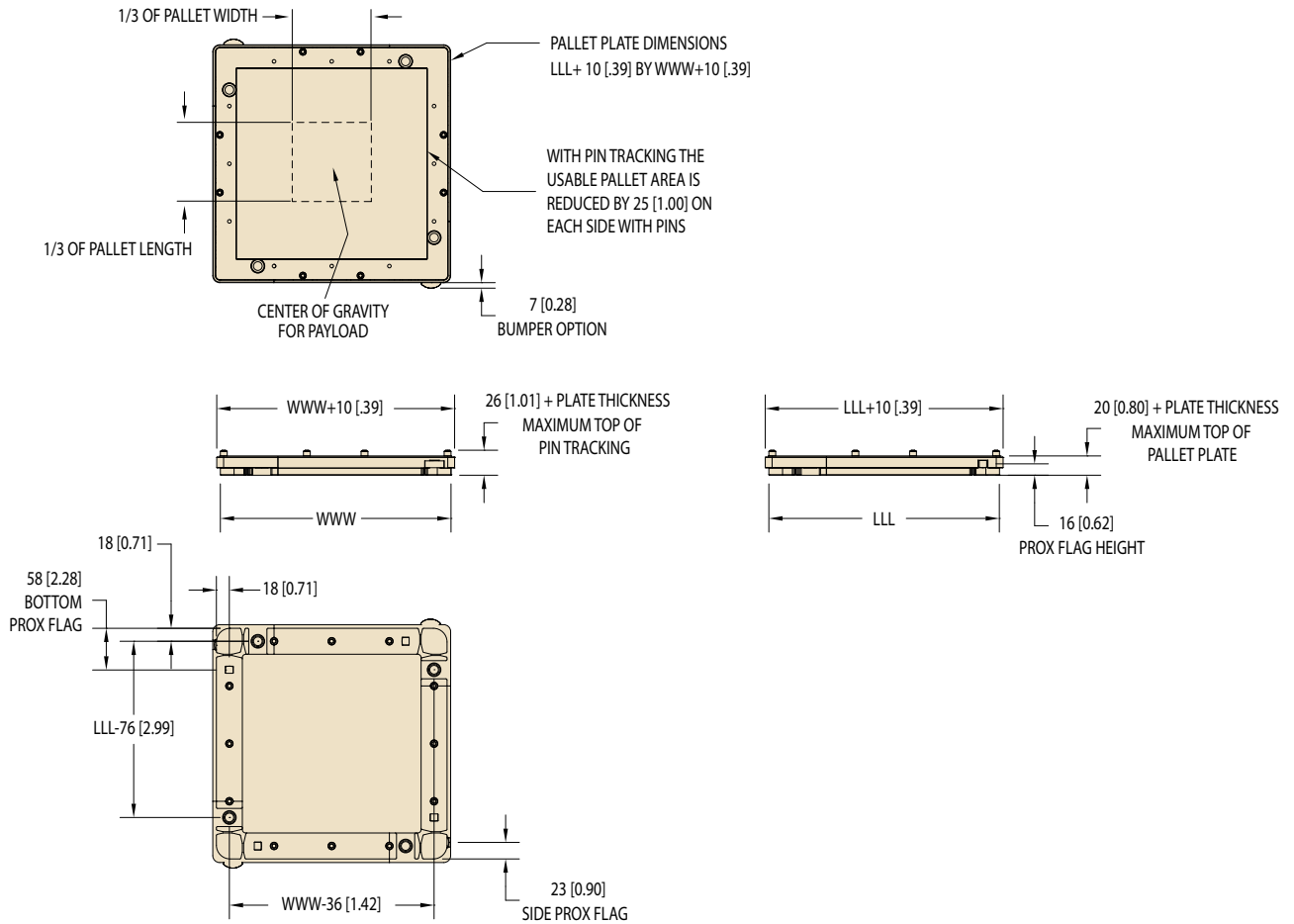
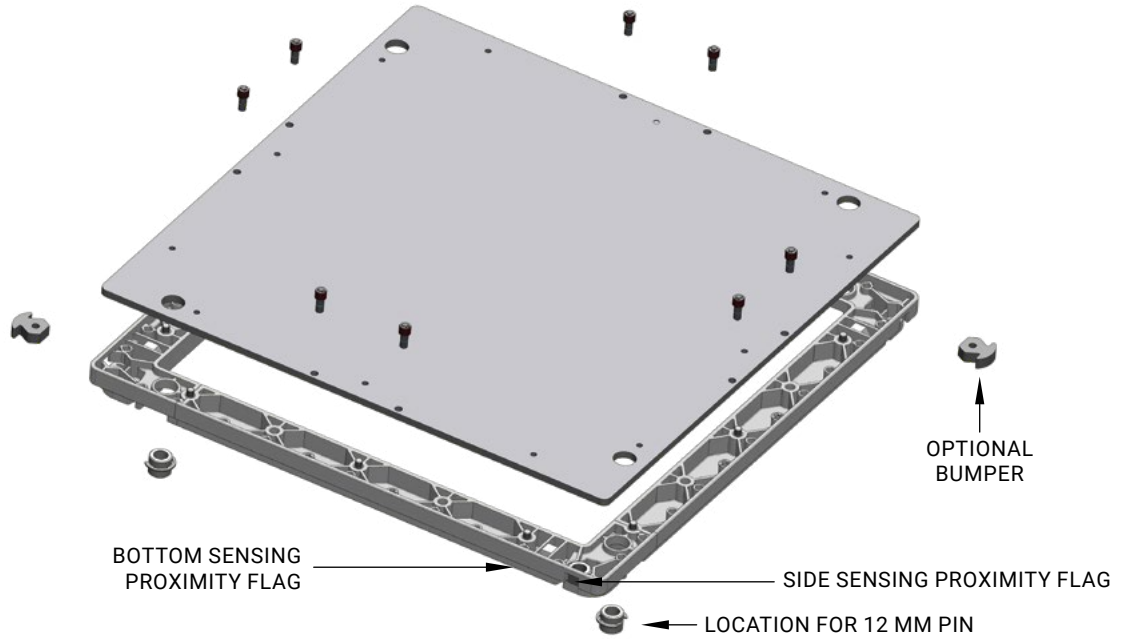

See page 54, 58-59 for detailed pallet weights and detailed pallet plate drawings.

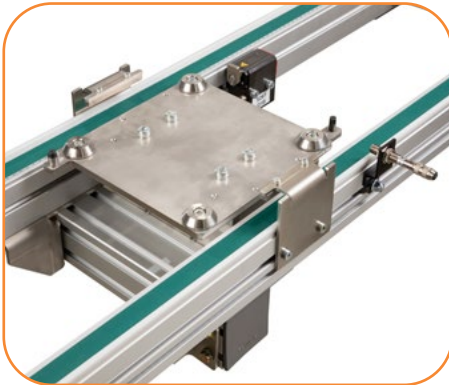
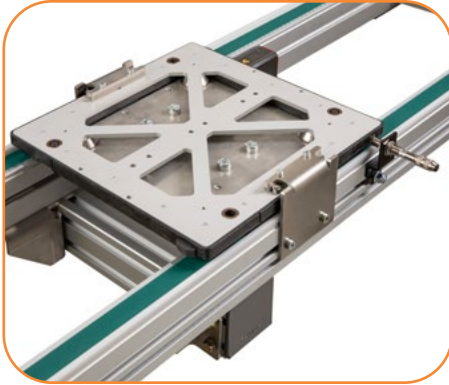

Specifications

- Lifts from center of conveyor
- Load Capacity based on 60psi air supply
 - widths 160 – 240mm 39kg (85 lbs)
 - widths 320 – 480mm 91kg (200 lbs)
 - widths 640 – 800mm 159kg (350 lbs)
- Repeatability of $\pm 0.13\text{mm}$ ($\pm 0.005\text{ in}$)
- Lift height is adjustable, maximum height is 38 mm (1.49 in) from top of belt to bottom of pallet
- Includes lift, pallet stop, mounting hardware and fittings for $\frac{1}{4}$ in push in air line
- Lift cylinder includes magnetic piston and 4 mm sensor track for C-Track proximity sensors. Sensors not included.
- Requires cushioned or non-cushioned pallet stop.
- Optional sensor mount for pallet. Sensor mounts are for standard 12 mm diameter proximity switch.
- Optional guarding package

Standard Pallet Sizes

		Length (mm)						
		160	240	320	400	480	640	800
Width (mm)	160	X	X					
	240	X	X	X		X		
	320		X	X		X		
	400				X	X		
	480		X	X	X	X	X	
	640					X	X	X
	800						X	X



RECOMMENDED ACCESSORY:
Pallet Guide Plate minimizes pallet twist

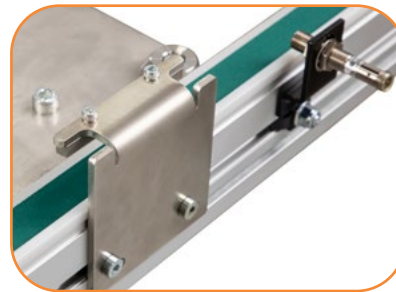

STANDARD FEATURE:
Vertical Locator Limit Bracket

Part Number 203747

DualMove Series: Lift and Locate

DS2	L	M	WWW	-	LLL	C	N	G

- Guarding: N = No Guarding G = Guarding Included
 - Pallet Sensor Bracket Option: N = No Sensor Bracket B = Bottom Sensor Bracket S = Side Sensor Bracket
 Bracket only (12mm sensors)
 - Stop Type: C = Cushioned F = Non-Cushioned N = None
 - Pallet Length Reference: 160 - 800 see chart
 - Pallet Width Reference: 160 - 800 see chart
 - Documentation Language: M = US-English U = Europe English D = German F = French S = Spanish
 - Conveyor Type: L = Standard high precision L&L E = Low Profile L&L

All combinations are valid except 160 mm width or length is not compatible with the bottom sensor bracket.

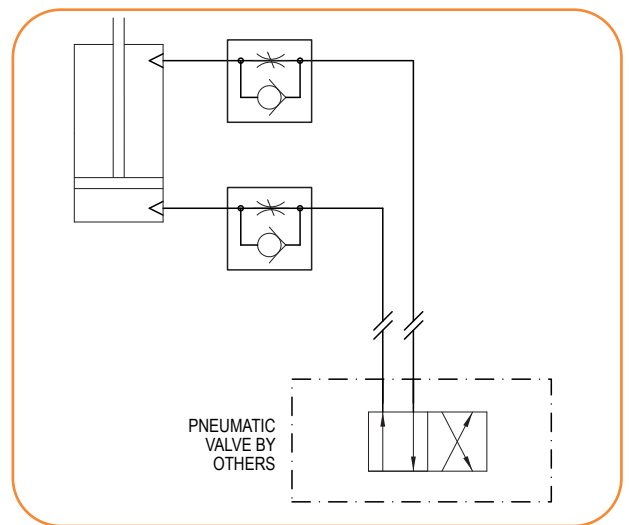
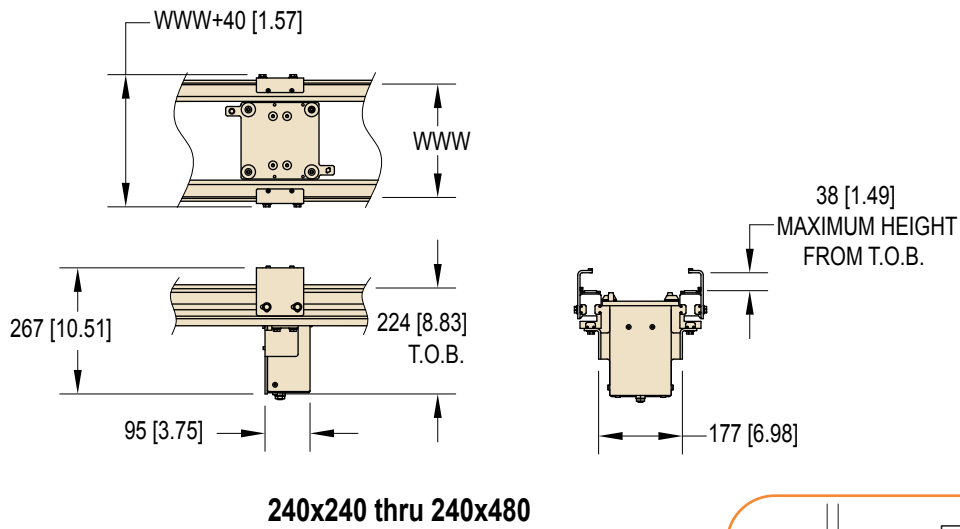
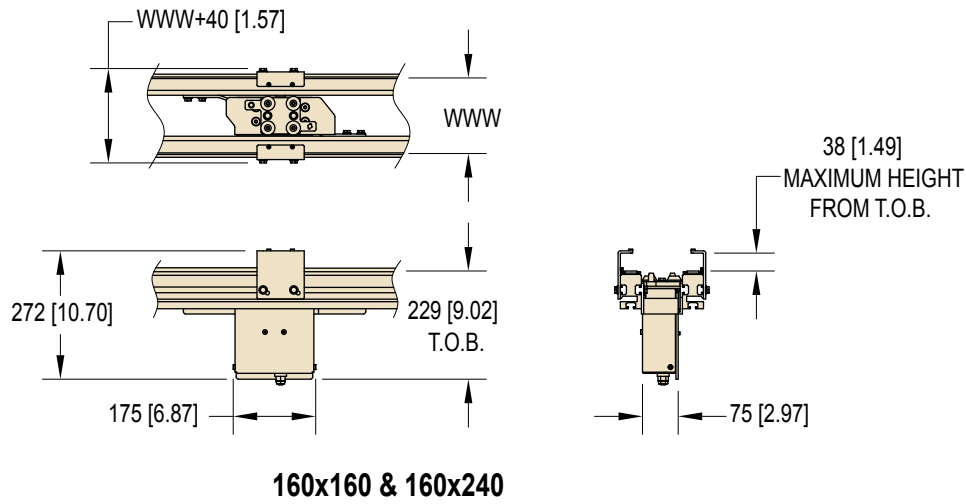

PNEUMATIC SCHEMATIC

For detailed module spacing, see page 55-57. For pneumatic specifications, see page 54.

Note: Due to the wide variety of drive setups and applications, point of installation guarding is the responsibility of the end user.
Note: Dimensions = mm (in)

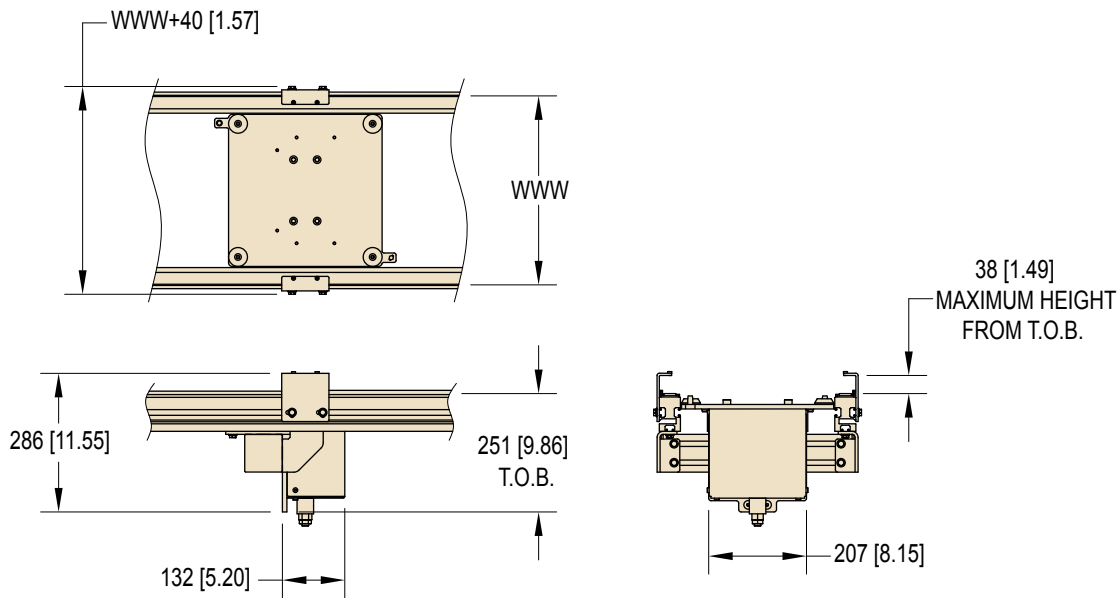

320x240 thru 480x640

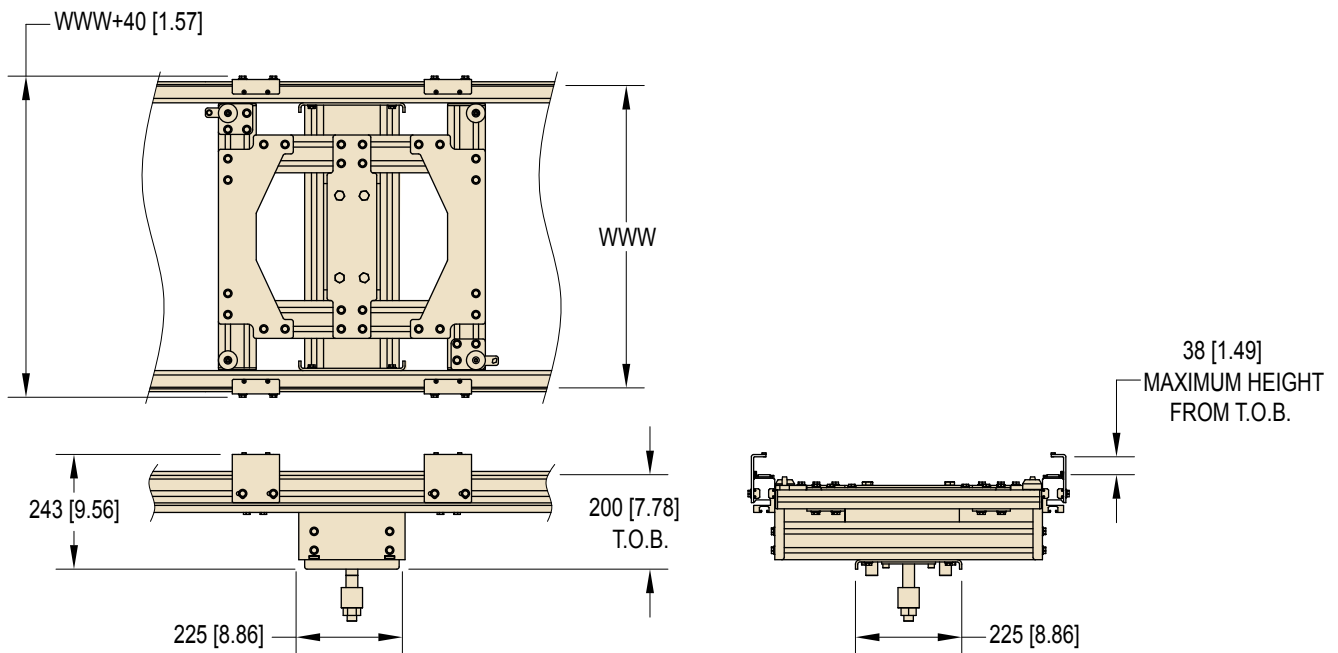

640x480 thru 800x800

For detailed module spacing, see page 55-57. For pneumatic specifications, see page 54.

Note: Due to the wide variety of drive setups and applications, point of installation guarding is the responsibility of the end user.

Note: Dimensions = mm (in)

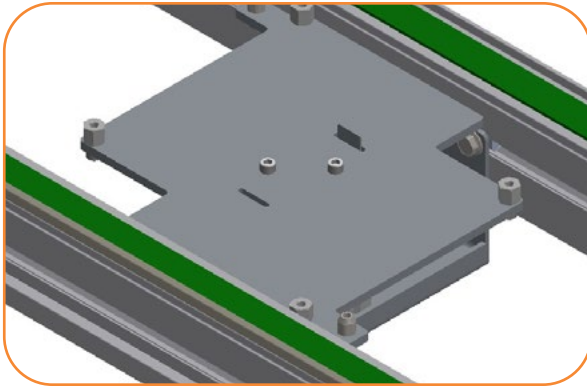

Specifications

- Lifts from center of conveyor
- Load Capacity based on 60 psi air supply
 - widths 160 - 240 mm 39kg (85 lbs)
 - widths 320 - 800 mm 91kg (200 lbs)
- Repeatability of ±0.38mm (±0.015 in)
- Lift height maximum height is 38 mm (1.49 in) from top of belt to bottom of pallet
- Includes lift, pallet stop, mounting hardware and fittings for ¼ in push in air line
- Lift cylinder includes magnetic piston and 4 mm sensor track for C-Track proximity sensors. Sensors not included.
- Requires cushioned or non-cushioned pallet stop.
- Optional sensor mount for pallet. Sensor mounts are for standard 12 mm diameter proximity switch.
- Optional guarding package

Standard Pallet Sizes

		Length (mm)						
		160	240	320	400	480	640	800
Width (mm)	160	X	X					
	240	X	X	X		X		
	320		X	X		X		
	400				X	X		
	480		X	X	X	X	X	
	640					X	X	X
	800						X	X



**RECOMMENDED ACCESSORY:
Pallet Guide Plate minimizes pallet twist**

Part Number 203747

DualMove Series: Lift and Locate

DS2 L M WWW - LLL C N G

- Guarding: N = No Guarding G = Guarding Included
- Pallet Sensor Bracket Option: N = No Sensor Bracket B = Bottom Sensor Bracket S = Side Sensor Bracket Bracket only (12mm sensors)
- Stop Type: C = Cushioned F = Non-Cushioned N = None
- Pallet Length Reference: 160 - 800 see chart
- Pallet Width Reference: 160 - 800 see chart
- Documentation Language: M = US-English U = Europe English D = German F = French S = Spanish
- Conveyor Type: L = Standard high precision L&L E = Low Profile L&L

All combinations are valid except 160 mm width or length is not compatible with the bottom sensor bracket.

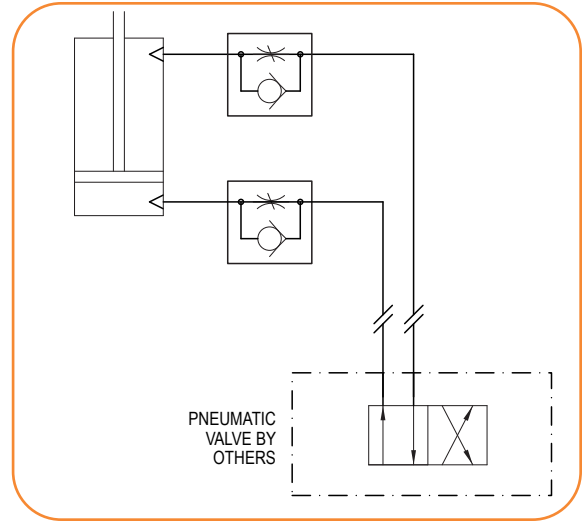
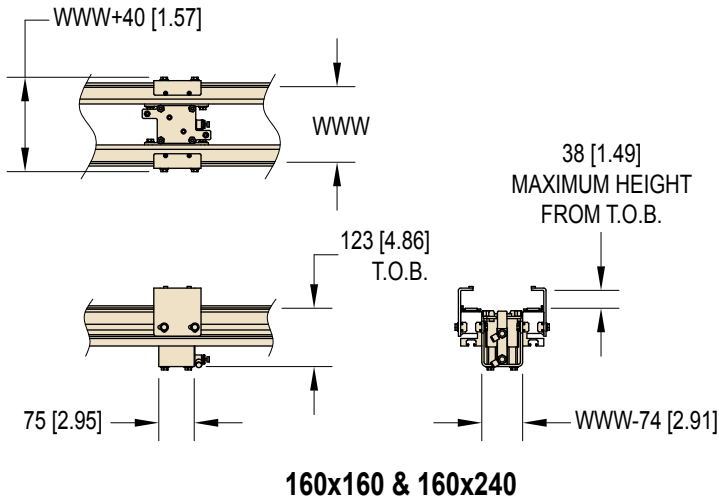

PNEUMATIC SCHEMATIC

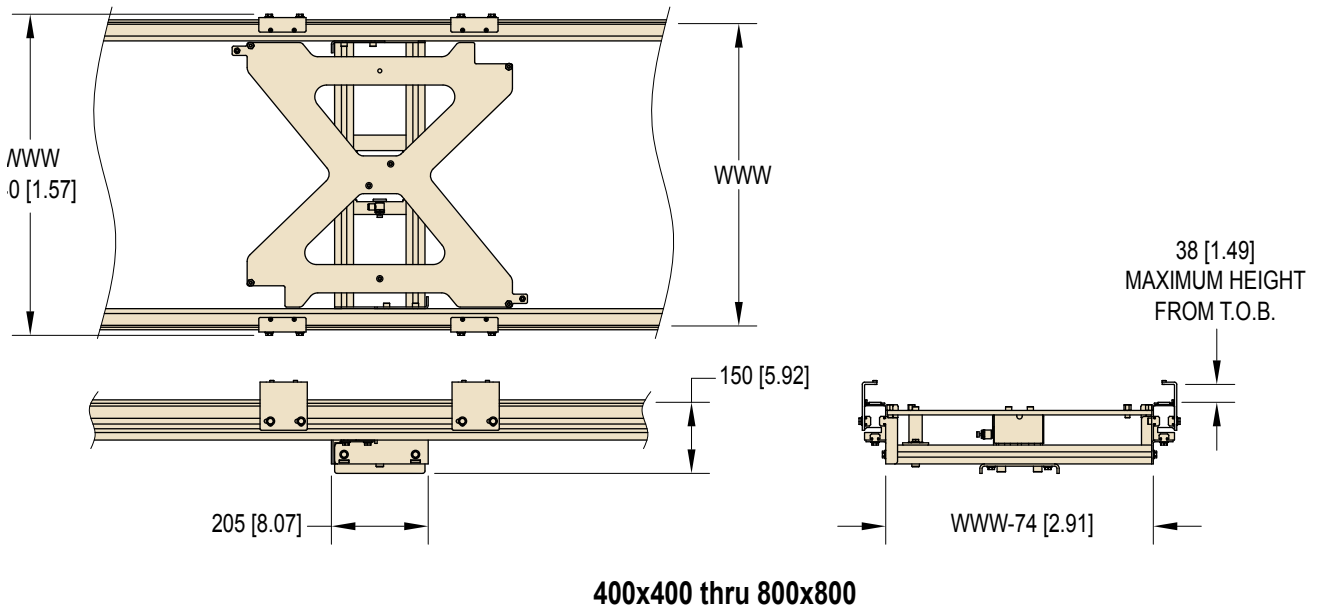
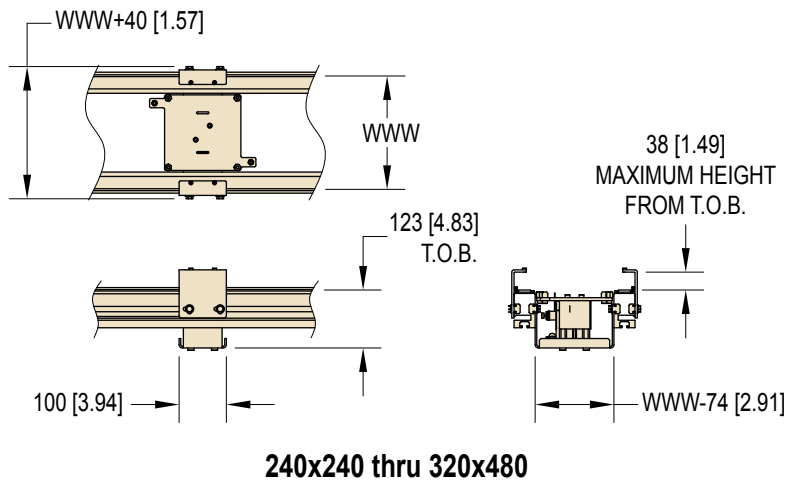

For detailed module spacing, see page 55-57. For pneumatic specifications, see page 54.

Note: Due to the wide variety of drive setups and applications, point of installation guarding is the responsibility of the end user.
Note: Dimensions = mm (in)



Specifications

- 2 position Lift and Transfer
 - Up position transfers pallet on/off the transverse conveyor
 - Down position allows pallet to pass transfer unit and/or stops prior to transferring.
- Changes product orientation at 90 degree corner
- capacity matches pallet's max load, up to 45 kg (100 lbs).
- Allows transfer to two directions if required
- Pallet transfers over conveyor high side. 8 mm (0.31 in) change
 - No guide cutting required
- Includes (1) 24VDC Brushless
 - 3.0 Amps starting current, 2.5 Amps rated torque
 - Available transfer speeds: 10, 15, 20, 25, 37m/min
 - Requires 24VDC power and single 24V PNP input to run
- Conveyor tie brackets see page 44 for details
- Multiple configurations available; sending/receiving and end-stop/pass-thru. see page 52 for configurations details
- Options:
 - Pallet sensor bracket .
 - Optional guarding package
 - Cushioned or non-cushioned pallet stops

		Length (mm)						
		160	240	320	400	480	640	800
Width (mm)	160	X	X					
	240	X	X	X		X		
	320		X	X		X		
	400				X	X		
	480		X	X	X	X	X	
	640					X	X	X
	800						X	X

DualMove Series: Lift and Transfer

DS2 T M WWW - LLL C F N G S S C

- Controller: A = Includes Digital Controller
- Speed: 1 = 10 mpm 2 = 15 mpm 3 = 20 mpm 4 = 25 mpm 5 = 37 mpm
- Sensor Bracket: N = No Sensor S = Side Sensor Bracket R = Rocker Switch Bracket
- Guarding: N = No Guarding G = Guarding Included
- Direction: S = Sending R = Receiving
- Flow Option: E = End Stop P = Pass Thru T = Transfer
- Cushion Option: C = Cushioned Stop F = Non-Cushioned Stop N = No Stop (Transfer only)
- Pallet Length Reference: 160 - 800 see chart
- Pallet Width Reference: 160 - 800 see chart
- Documentation Language: M = US-English U = Europe English D = German F = French S = Spanish
- Conveyor Type: T = Lift and Transfer

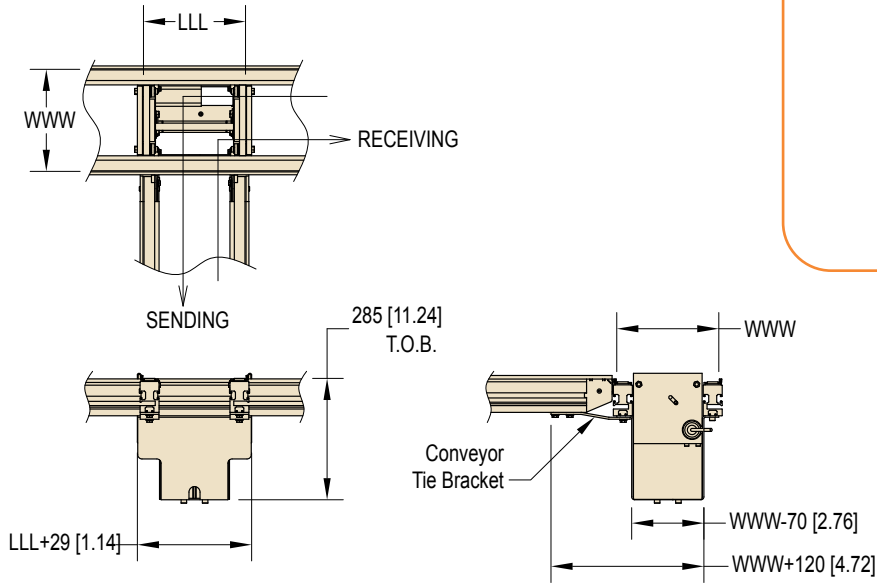

160x160 thru 240x480

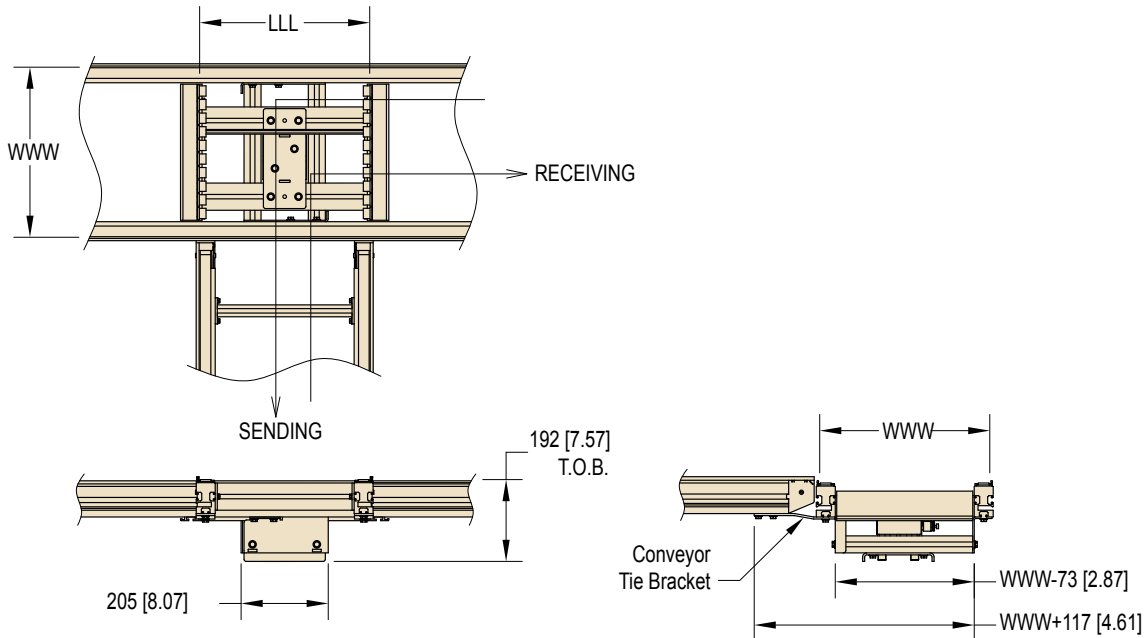

320x240 thru 480x640

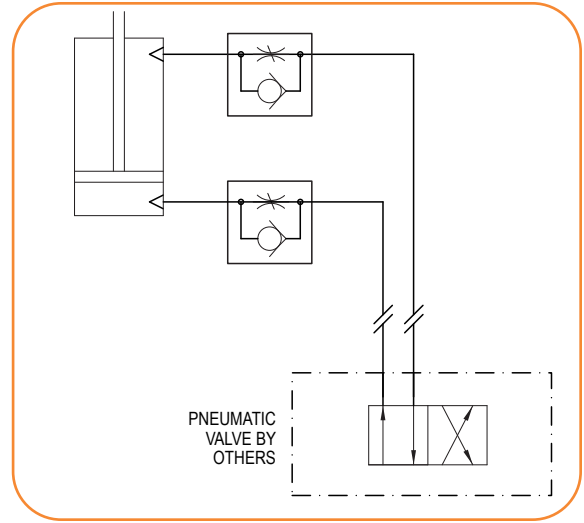

PNEUMATIC SCHEMATIC

For detailed module spacing, see page 55-57. For pneumatic specifications, see page 54.

Note: Due to the wide variety of drive setups and applications, point of installation guarding is the responsibility of the end user.
Note: Dimensions = mm (in)

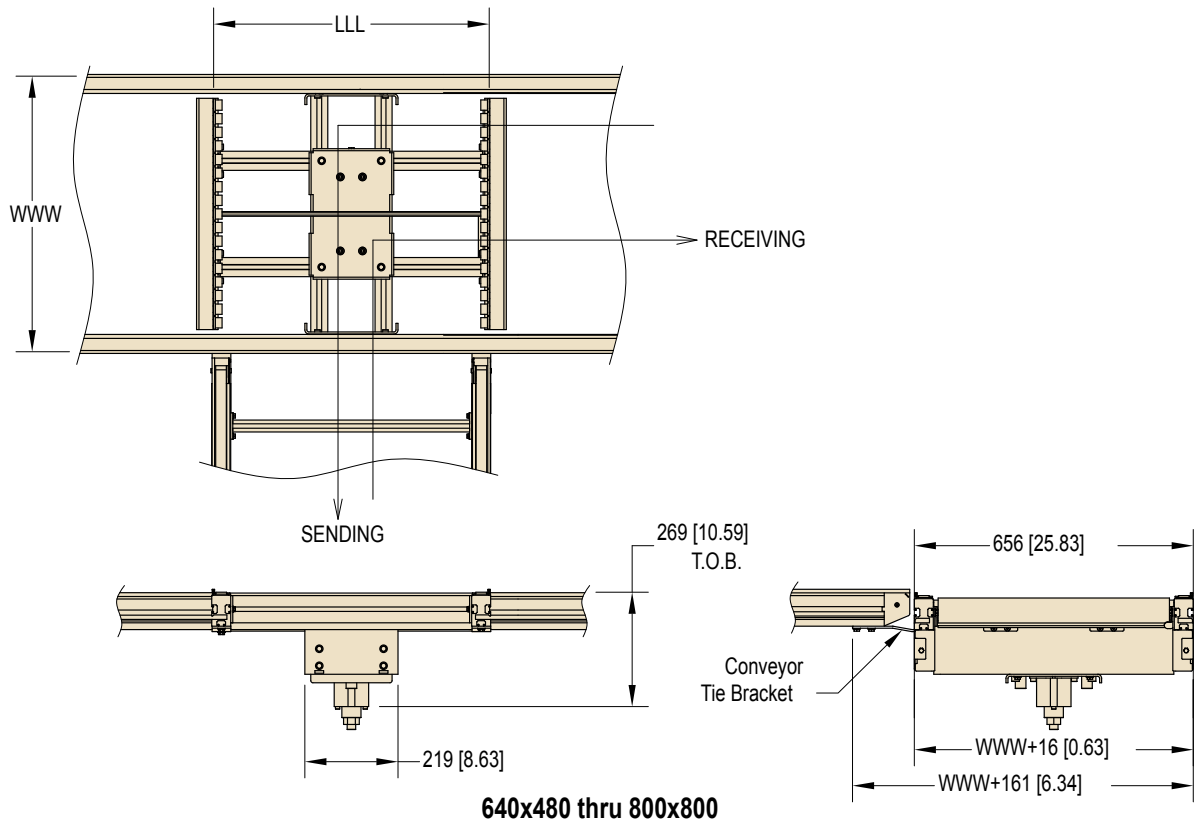

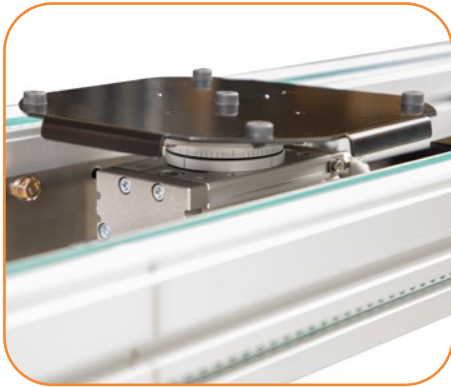
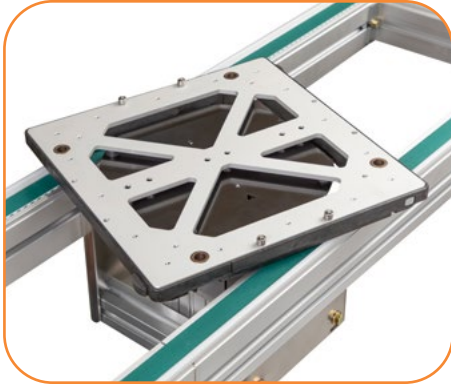

Specifications

- Pneumatic lift from center of conveyor
- Pneumatic rotation with adjustable positioning
- Includes break-away magnetic coupled rotation plate for product safety
- Rotation angle: 90 and 180 degrees Note: 90 degree rotation only available in square pallets.
- Includes cushioned turn strokes
- Load capacity matches maximum pallet loads
- Includes mechanism, mounting hardware and fittings for ¼ in push in air line
- Lift and Rotate cylinders include magnetic pistons and 4 mm sensor track for C-track proximity sensors. Sensors not included.
- Optional cushioned or non-cushioned pallet stop.
- Optional sensor mount for pallet. Sensor mounts are for standard 12 mm diameter proximity switch.
- Optional guarding package

Standard Pallet Sizes

		Length (mm)						
		160	240	320	400	480	640	800
Width (mm)	160	X	X					
	240	X	X	X		X		
	320		X	X		X		
	400				X	X		
	480		X	X	X	X	X	
	640					X	X	X
	800						X	X



Optional Guarding Package



STANDARD FEATURE:
Breakaway Top Plate



RECOMMENDED ACCESSORY:
Pallet Guide Plate minimizes pallet twist

Part Number 203747

DualMove Series: Lift and Rotate

DS2 R M WWW - LLL A C N G

Guarding: N = No Guarding G = Guarding Included
 Pallet Sensor Option: N = No Sensor Bracket B = Bottom Sensor Bracket S = Side Sensor Bracket
 Stop Type: C = Cushioned F = Non-Cushioned N = None
 Degree: A = 90 degrees B = 180 degrees
 Pallet Length Reference: 160 - 800 see chart
 Pallet Length Reference: 160 - 800 see chart
 Documentation Language: M = US-English U = Europe English D = German F = French S = Spanish
 Conveyor Type: R = Lift and Rotate

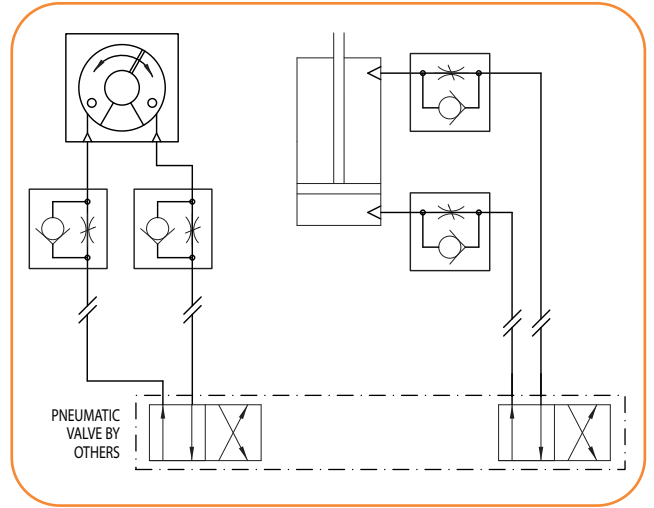
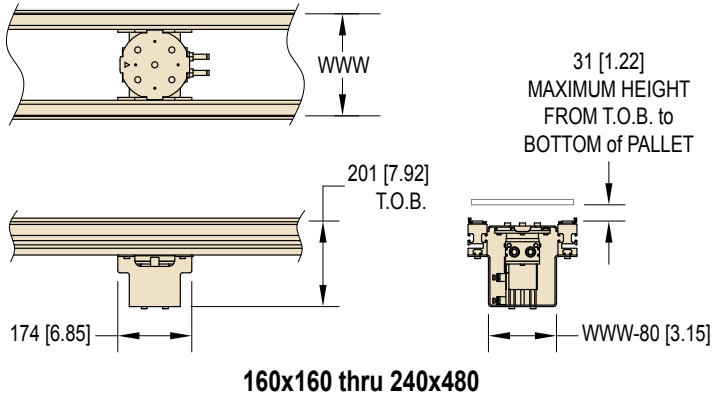

PNEUMATIC SCHEMATIC

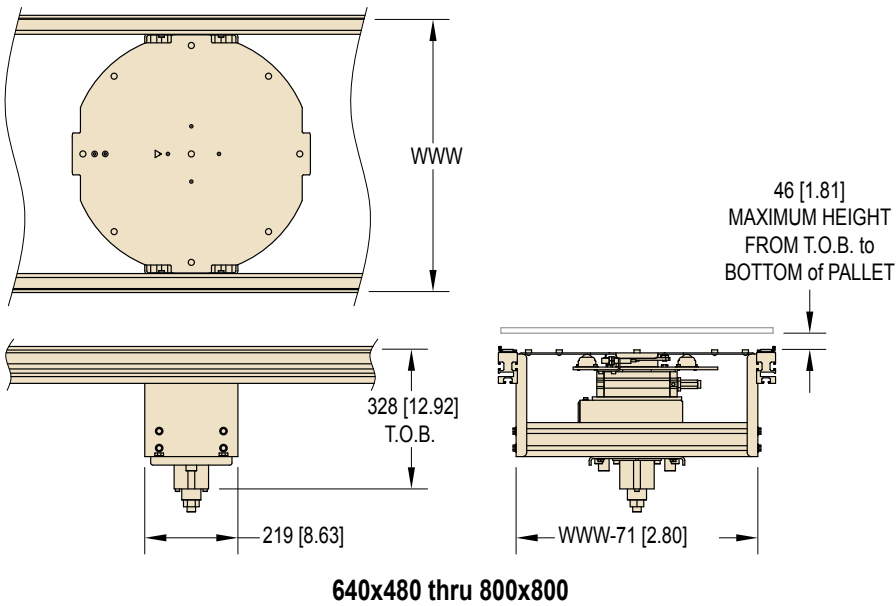
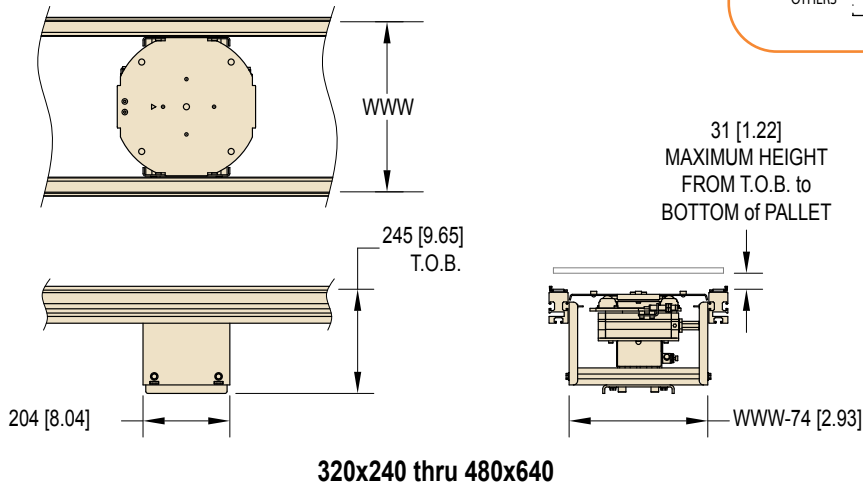

For detailed module spacing, see page 55-57. For pneumatic specifications, see page 54.

Note: Due to the wide variety of drive setups and applications, point of installation guarding is the responsibility of the end user.
Note: Dimensions = mm (in)



Specifications

- Requires pin tracking capability in pallet
- 25 mm (1 in) of pallet space at side of pins required
- Up to 32 kg (70 lbs) load capacity
- Maintains product orientation around the corner
- Product accumulation in the corner is not recommended
- Inside guide is fixed mounted to transfer pallet around corner
- 24VDC mini-conveyors drive the pallet around the corner
- Mini-conveyor includes 24V Brushless DC drive motors with controls
 - 60 W output, Rated 4 Amps (0.3 Amps under no load)
 - Belt Speed: 25–126 ft/min.
 - Includes switch box (FWD/OFF/REV) switch, speed potentiometer, and wire output to remotely control ON/OFF function via 24VDC signal.

		Standard Pallet Sizes						
		Length (mm)						
Width (mm)		160	240	320	400	480	640	800
	160	X	X					
	240	X	X	X				
	320		X	X				
	400							
	480							
	640							
	800							

For large pallet sizes see heavy load corners.

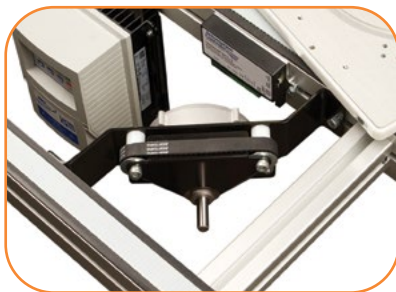

Mini Conveyor Drives Pallet around Corner



Pin Tracking

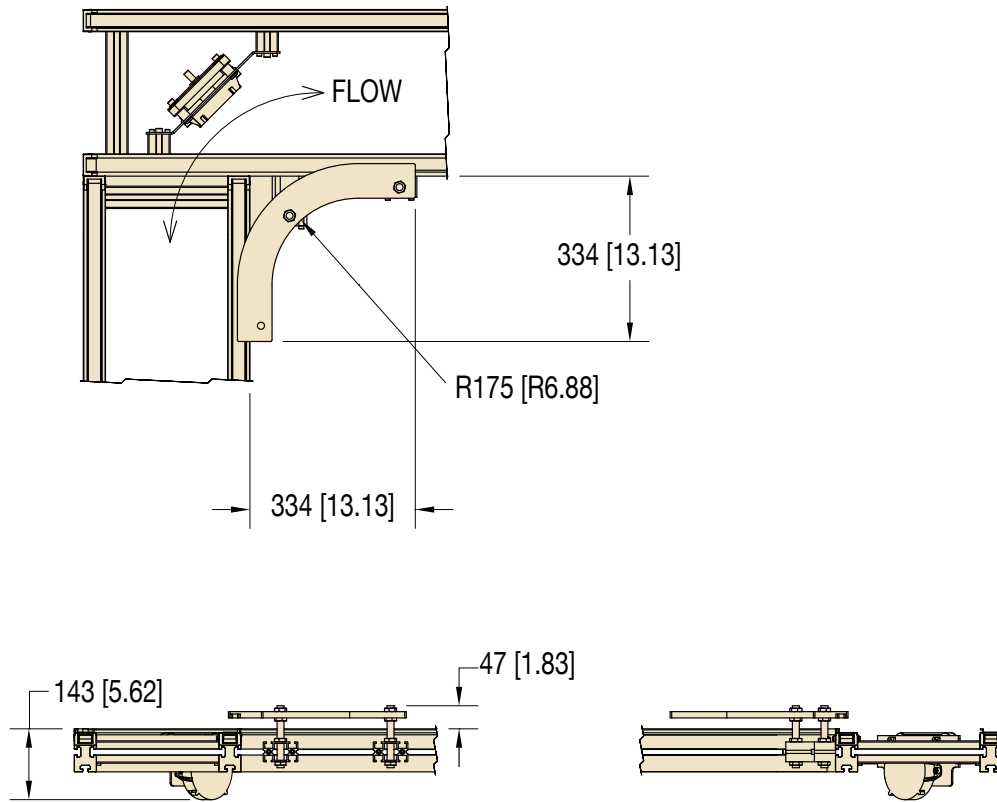

DualMove Series: 90 Degree Corner

DS 2	T	M	WWW	D
				- Direction: L = Right R = Right
				- Pallet Width Reference: 160 = 160 mm 240 = 240 mm 320 = 320 mm
				- Documentation Language: M = US-English
				- Conveyor Type: T = Fixed Corner Turn

For detailed module spacing, see page 55-57. For pneumatic specifications, see page 54.

Note: Due to the wide variety of drive setups and applications, point of installation guarding is the responsibility of the end user.
Note: Dimensions = mm (in)



Specifications

- Requires pin tracking capability in pallet
- 25 mm (1 in) of pallet space at side of pins required
- Up to 32 kg (70 lbs) load capacity
- Maintains product orientation around the corner
- Product accumulation in the corner is not recommended
- Inside guide is fixed mounted to transfer pallet around corner
- Two 24VDC mini-conveyors drive the pallet around the corner
- Mini-conveyors include two 24V Brushless DC drive motors with controls
 - Each motor: 60 W output, rated 4 Amps (0.3 Amps under no load)
 - Belt Speed: 25–126 ft/min.
 - Includes two switch boxes, each includes (FWD/OFF/REV) switch, speed potentiometer, and wire output to remotely control ON/OFF function via 24VDC signal.
- Includes support stand and hardware as separate line items

Standard Pallet Sizes

		Length (mm)						
		160	240	320	400	480	640	800
Width (mm)	160	X	X					
	240	X	X	X				
	320		X	X				
	400							
	480							
	640							
	800							

For large pallet sizes see heavy load corners.

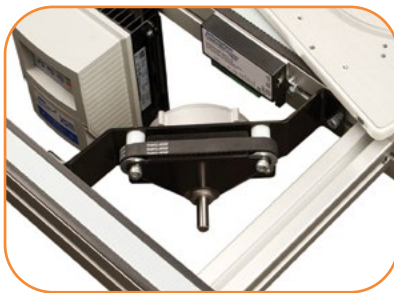

Mini Conveyor Drives Pallet around Corner



Pin Tracking

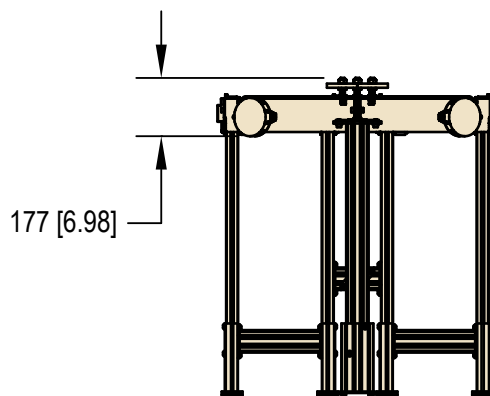
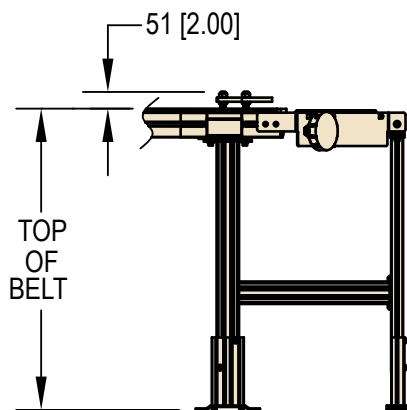
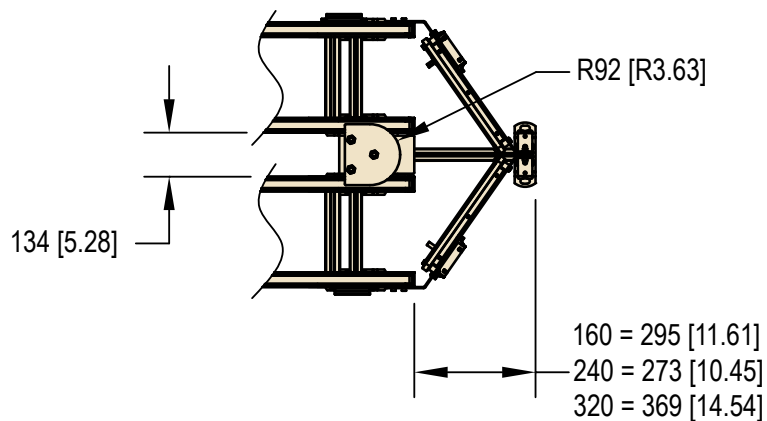

DualMove Series: 180 Degree Corner										
DS2	U	M	WWW	-	AAA	LH	UH	F	D	
										- Direction: L = Left R = Right
										- Footing: F = Fixed
										- Tallest Height to TOB (in inches)
										- Lowest Height to TOB (in inches)
										- Angle Reference: 180 = 180 Degree
										- Conveyor Width Reference: 160 = 160 mm 240 = 240 mm 320 = 320 mm
										- Documentation Language: M = US-English
										- Conveyor Type: U = 180 Degree Corner

All combinations are valid except 160 mm width or length is not compatible with the bottom sensor bracket.

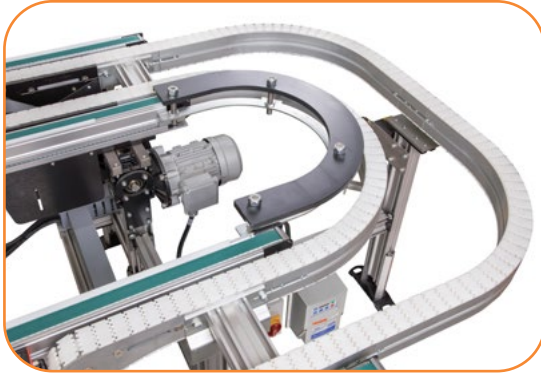

180° Corner

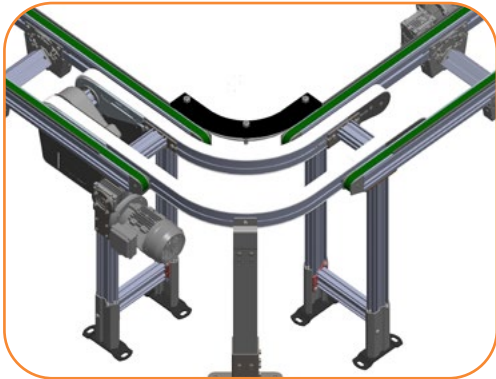

90° Corner



Pin Tracking

Specifications

- Requires pin tracking capability in pallet
- 25 mm (1 in) of pallet space at side of pins required
- 68 kg (150 lbs) load capacity
- Maintains product orientation around the corner
- Product accumulation in the corner is allowed 34 kg (75 lbs) maximum
- Inside guide is fixed mounted to transfer pallet around corner
- Includes support stand and hardware as separate line items
- Belt Speed is matched to main lines
- Separate gearmotor and drive is required for the corner conveyor.

Standard Pallet Sizes

	Length (mm)						
	160	240	320	400	480	640	800
160							
240					X		
320					X		
400				X	X		
480		X	X	X	X	CF	
640					CF	CF	CF
800						CF	CF

CF = Consult the Factory for availability and total load capacity

DualMove Series: Heavy Load 90 and 180 Degree Corner

DS2 H M WWW - AAA LH UH F D

- Direction: L = Left R = Right
- Footing: F = Fixed
- Tallest Height to TOB (in inches)
- Lowest Height to TOB (in inches)
- Angle Reference: 090 = 90 Degree 180 = 180 Degree
- Conveyor Width Reference: 320 = 320 mm 400 = 400 mm 480 = 480 mm
- Documentation Language: M = US-English
- Conveyor Type: H = Heavy Load Corner

All combinations are valid except 160 mm width or length is not compatible with the bottom sensor bracket.

For detailed module spacing, see page 55-57. For pneumatic specifications, see page 54.

90 Degree Corner

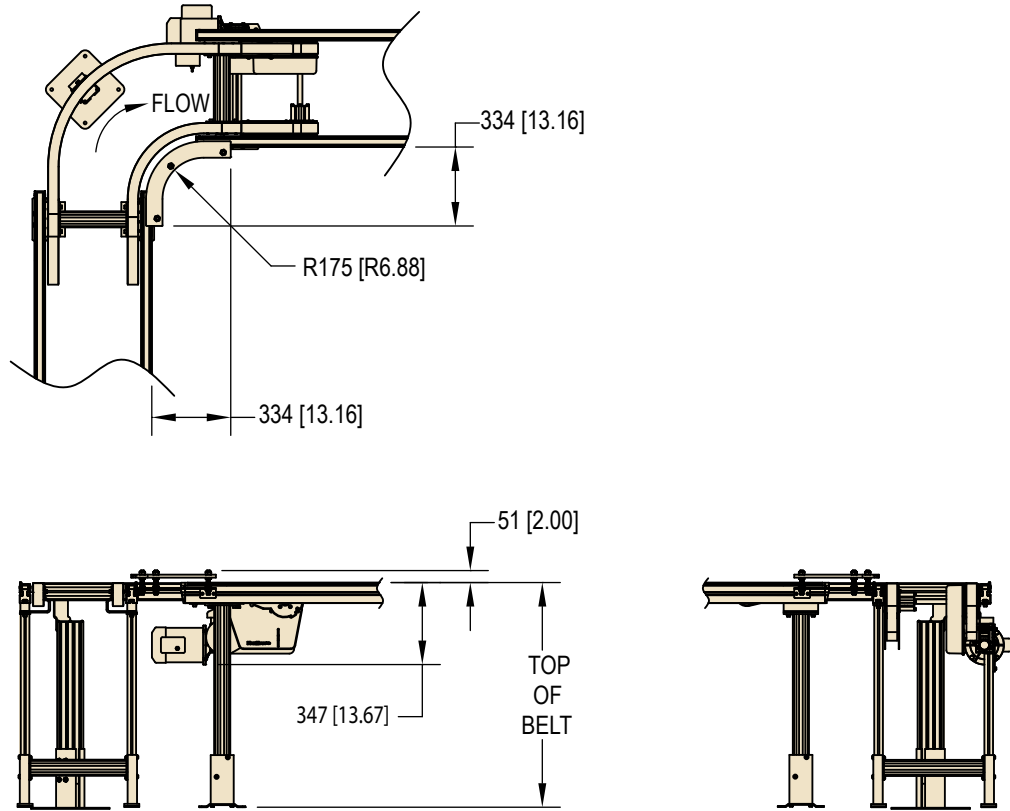

180 Degree Corner

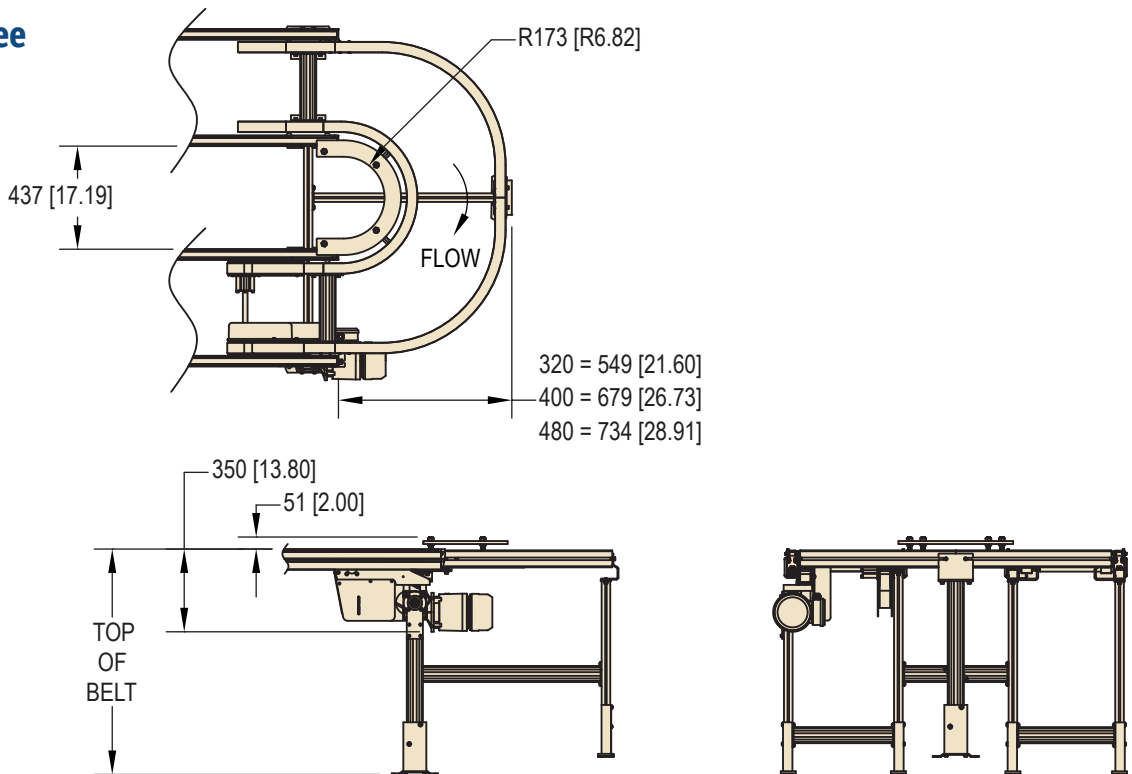

Note: Due to the wide variety of drive setups and applications, point of installation guarding is the responsibility of the end user.

Note: Dimensions = mm (in)

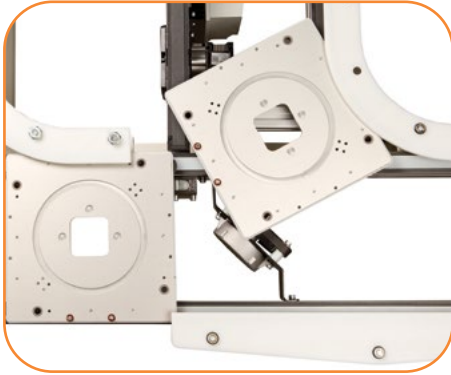

Specifications

- Requires pin tracking capability in pallet
- 25 mm (1 in) of pallet space at side of pins required
- 32 kg (70 lbs) load capacity
- Maintains product orientation
- Inside guide is raised with pneumatic cylinders to clear flow through
- Straight guide with pneumatic cylinder is mounted across perpendicular conveyor to guide pallets straight through the merge area
- Includes sensor mount track on guide cylinder for C-track 4 mm proximity sensors
- 160 mm wide units have no added mini-conveyor
- 240 mm and 320 mm have a 24VDC mini-conveyor added to drive the pallet around the corner
- Mini-conveyor includes 24V Brushless DC drive motor with controls
 - 60 W output, rated 4 Amps (0.3 Amps under no load)
 - Belt Speed: 25–126 ft/min.
 - Includes switch boxes (FWD/OFF/REV) switch, speed potentiometer, and wire output to remotely control ON/OFF function via 24VDC signal.
- Requires pallet stops for traffic control. See page 32-35.
- Requires support stand or conveyor tie bracket to connect conveyors. See pages 43-44.

Standard Pallet Sizes

		Length (mm)						
		160	240	320	400	480	640	800
Width (mm)	160	X	X					
	240	X	X	X				
	320		X	X				
	400							
	480							
	640							
	800							

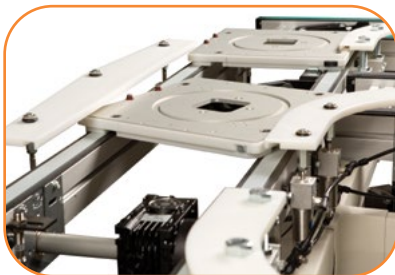

**Pneumatic Activated
Transfer Guides**

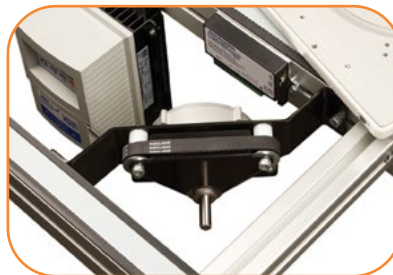

**Mini Conveyor Drives
Pallet around Corner**



Pin Tracking

Note: Due to the wide variety of drive setups and applications, point of installation guarding is the responsibility of the end user.
Note: Dimensions = mm (in)

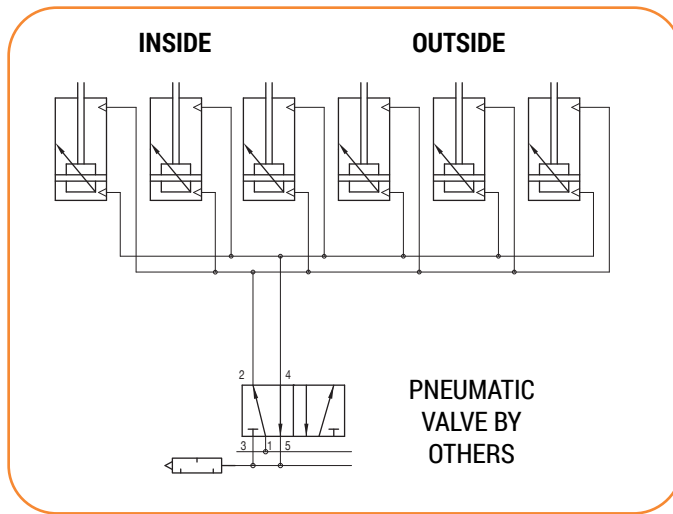
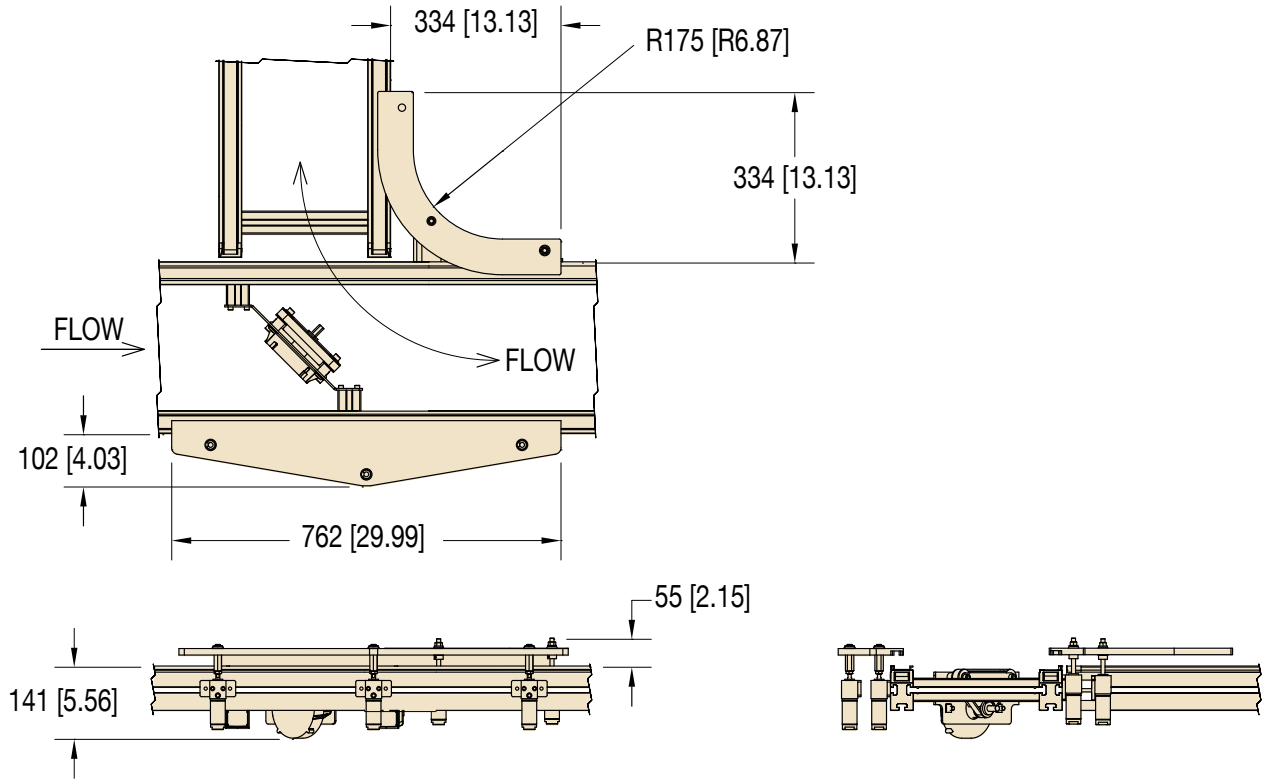

PNEUMATIC SCHEMATIC

DualMove Series: 90 Degree Corner and Merge

DS2 M M WWW - N D

- Direction: L = Right R = Right
- Pallet Sensor Option: N = No Sensor Bracket B = Bottom Sensor Bracket S = Side Sensor Bracket
- Pallet Width Reference: 160 = 160 mm 240 = 240 mm 320 = 320 mm
- Documentation Language: M = US-English
- Conveyor Type: M = Merge Corner

For pneumatic specifications, see page 54.

Note: Due to the wide variety of drive setups and applications, point of installation guarding is the responsibility of the end user.
Note: Dimensions = mm (in)

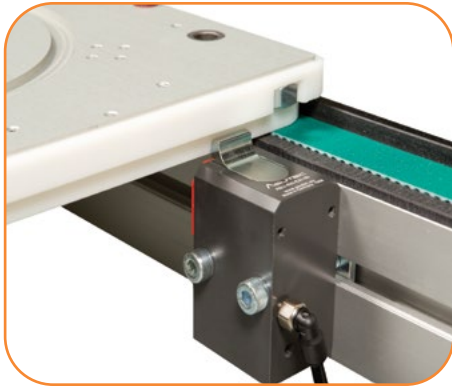

Pallet Stop – Non-cushioned

Non-cushioned pallet stop for traffic control. Stops one or more pallets at the specified location on the conveyor. Air pressure disengages the stop allowing pallets to pass until the pressure is released. A spring return re-engages the pallet stop.

Specifications

- Maximum Load: 68 kg (150 lbs) accumulated
- Pneumatically activated, spring return
- Not suitable for reversing application
- Mounts on the inside of the conveyor rail
- Airline can be mounted on the front or back of the stop
- Includes: stop, mounting hardware, and fittings for ¼ in push in air line
- Optional vertical or side mounted sensor bracket. See page 45.

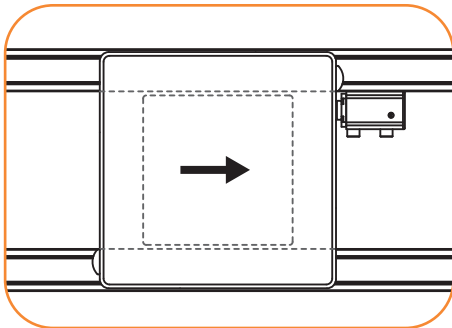

Stop Located After Pallet

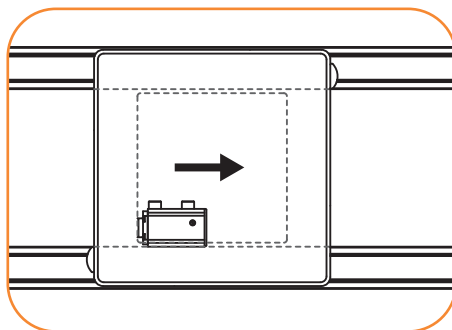

Stop Located Inside Pallet

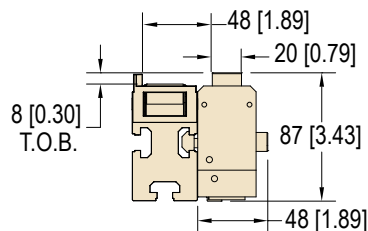
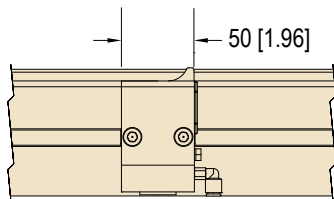
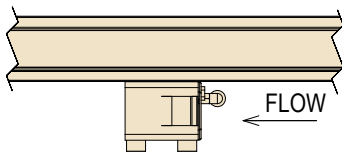

Part Number DS2SM-SFx where x: **N** = no sensor, **B** = Bottom sensor, **S** = side sensor

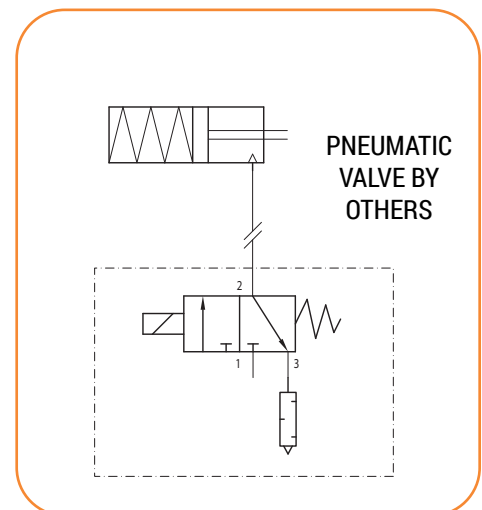
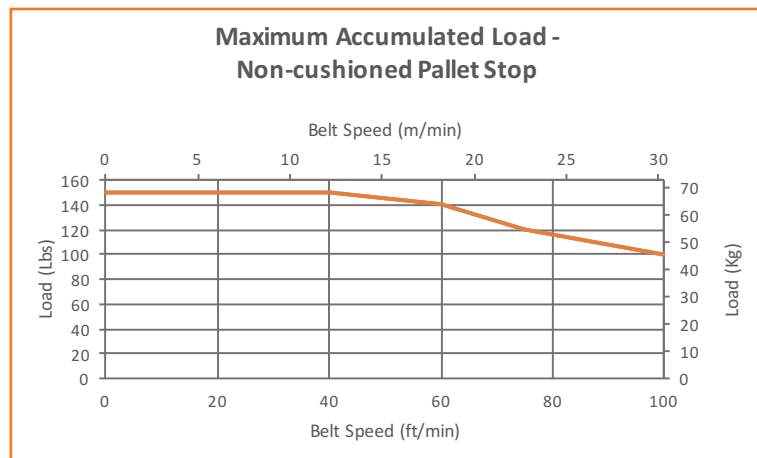

PNEUMATIC SCHEMATIC

For pneumatic specifications, see page 54.

Note: Due to the wide variety of drive setups and applications, point of installation guarding is the responsibility of the end user.
Note: Dimensions = mm (in)

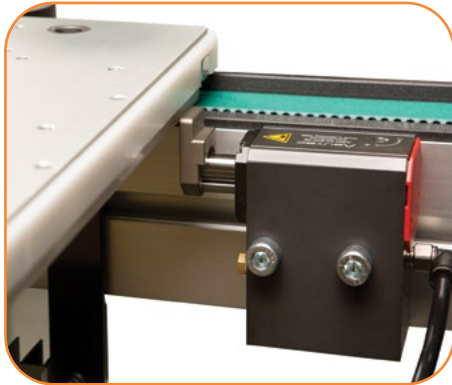

Pallet Stop – Cushioned

Cushioned pallet stop for traffic control. Stops one or more pallets at the specified location on the conveyor. Cushioned deceleration of the first pallet into the stopped location guarding against vibration of sensitive payloads. Accumulated pallets are not cushioned. Air pressure disengages the stop allowing pallets to pass until the pressure is released. A spring return re-engages the pallet stop and resets the cushion.

Specifications

- Maximum Load: 150 lbs (68 kg) accumulated
- Pneumatically activated, spring return
- Stops the pallet on the leading or trailing edge
- Not suitable for reversing application
- Mounts on the inside of the conveyor rail
- Airline can be mounted on the front or back of the stop
- Includes: stop, mounting hardware, and fittings for ¼ in push in air line
- Optional vertical or side mounted sensor bracket. See page 45.

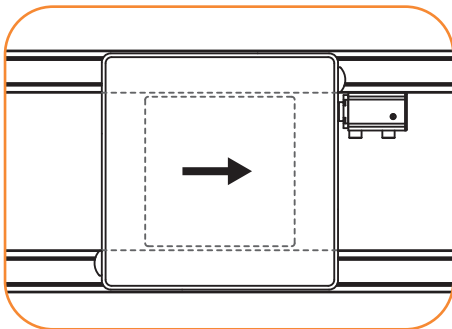

Stop Located After Pallet

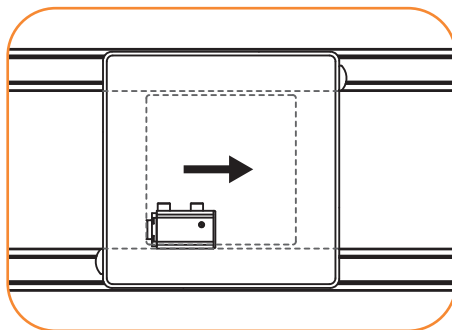

Stop Located Inside Pallet

Part Number DS2SM-SCx where x: **N** = no sensor, **B** = Bottom sensor, **S** = side sensor

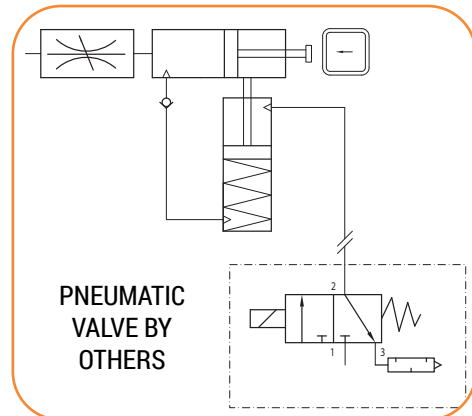
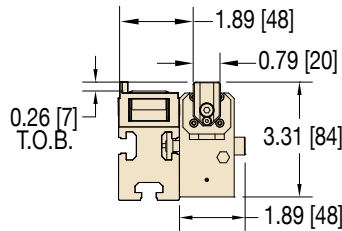
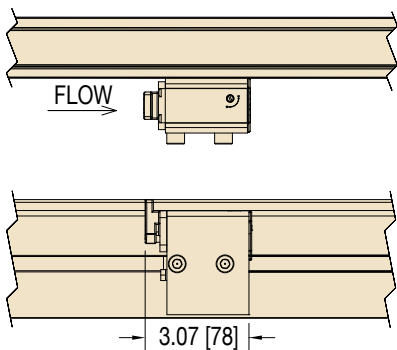
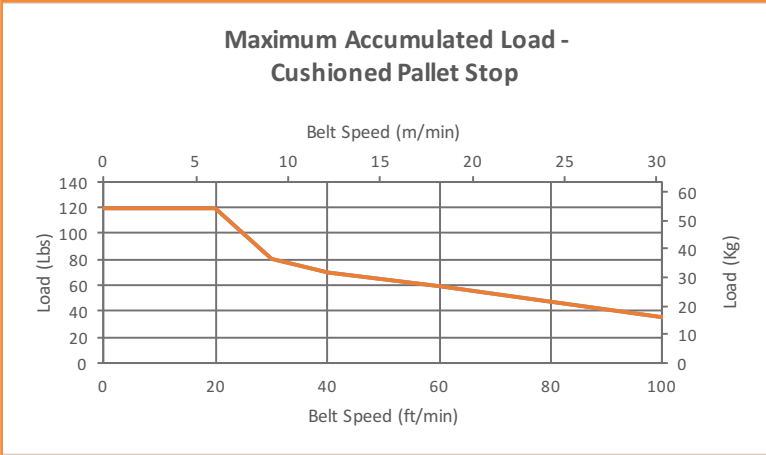

PNEUMATIC SCHEMATIC

For pneumatic specifications, see page 54.

Note: Due to the wide variety of drive setups and applications, point of installation guarding is the responsibility of the end user.

Note: Dimensions = mm (in)



Heavy Load Pallet Stop – Non-cushioned

Non-cushioned pallet stop for traffic control. Stops one or more pallets at the specified location on the conveyor. Air pressure disengages the stop allowing pallets to pass until the pressure is released. A spring return re-engages the pallet stop.

Specifications

- Maximum Load: 250 kg (550 lbs) accumulated
- Recommended for pallets wider than 400 mm
- Pneumatically activated, spring return
- Mounts on the inside of the conveyor rail
- Airline can be mounted on the front or back of the stop
- Includes: stop, mounting hardware, and fittings for 6.3 mm (¼ in) push in air line
- Optional vertical or side mounted sensor bracket. See page 45

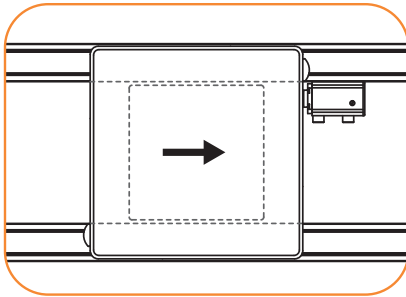

Stop Located After Pallet

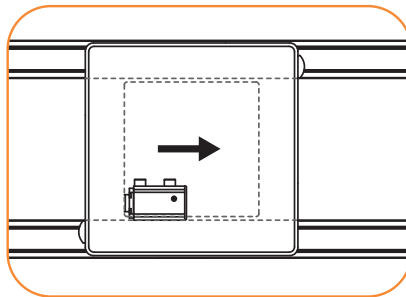

Stop Located Inside Pallet

Part Number DS2SM-HFx where x: **N** = no sensor, **B** = Bottom sensor, **S** = side sensor

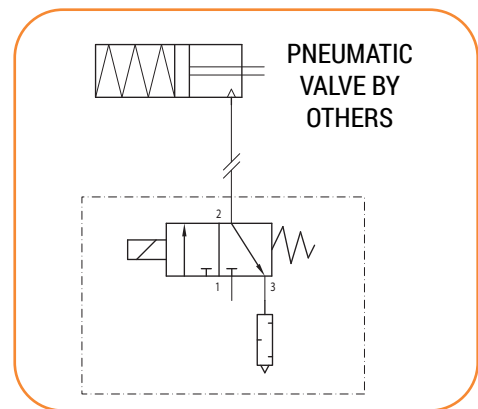
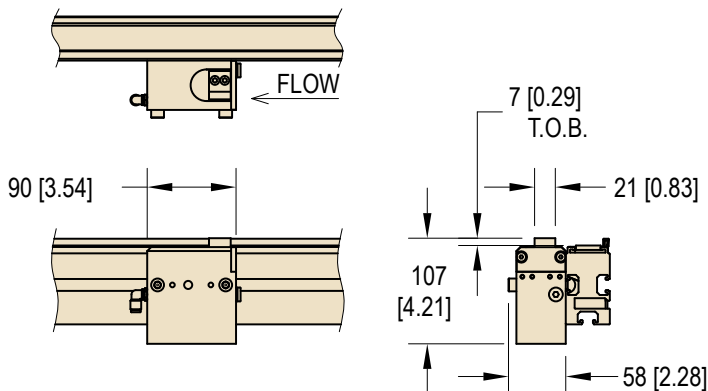
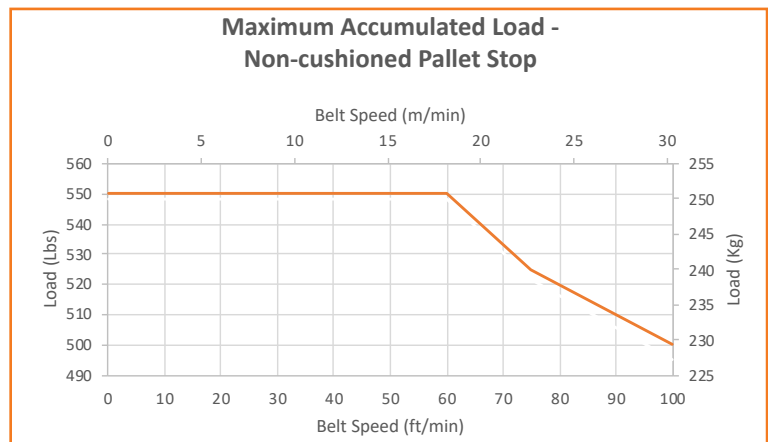

For pneumatic specifications, see page 54.

Note: Due to the wide variety of drive setups and applications, point of installation guarding is the responsibility of the end user.
Note: Dimensions = mm (in)

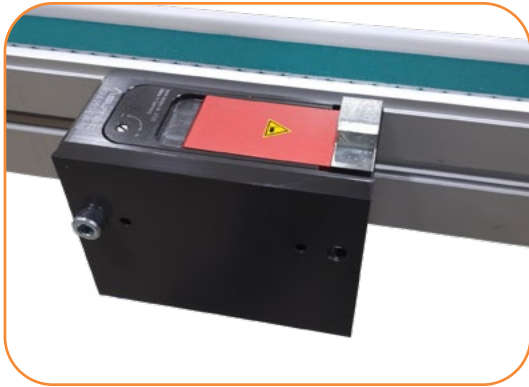

Heavy Load Pallet Stop – Cushioned

Cushioned pallet stop for traffic control. Stops one or more pallets at the specified location on the conveyor. Cushioned deceleration of the first pallet into the stopped location, guarding against vibration of sensitive payloads. Accumulated pallets are not cushioned. Air pressure disengages the stop allowing pallets to pass until the pressure is released. A spring return re-engages the pallet stop and resets the cushion

Specifications

- Maximum Load: 114 kg (250 lbs) accumulated
- Recommended for pallets wider than 400 mm
- Pneumatically activated, spring return
- Stops the pallet on the leading or trailing edge
- Mounts on the inside of the conveyor rail
- Airline can be mounted on the front or back of the stop
- Includes: stop, mounting hardware, and fittings for 6.3 mm (¼ in) push in air line
- Optional vertical or side mounted sensor bracket. See page 45

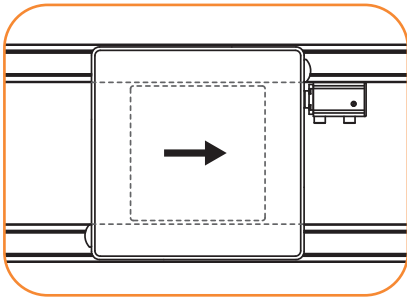

Stop Located After Pallet

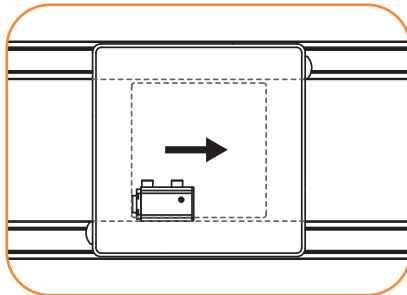

Stop Located Inside Pallet

Part Number	DS2SM-HCx where x: N = no sensor, B = Bottom sensor, S = side sensor
-------------	-------------------------------------------------------------------------------------------

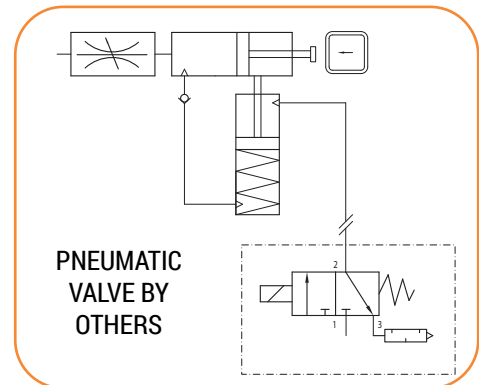
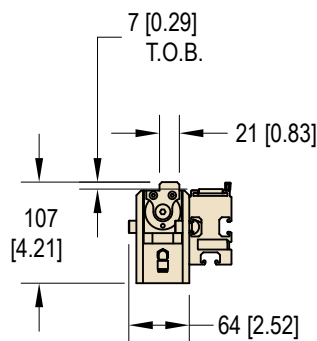
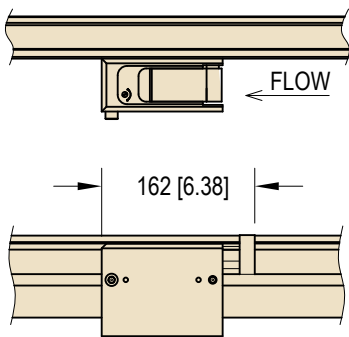
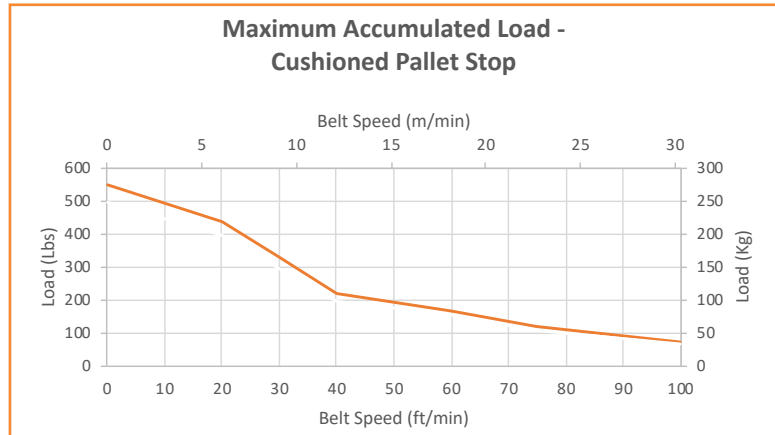

For pneumatic specifications, see page 54.

Note: Due to the wide variety of drive setups and applications, point of installation guarding is the responsibility of the end user.

Note: Dimensions = mm (in)

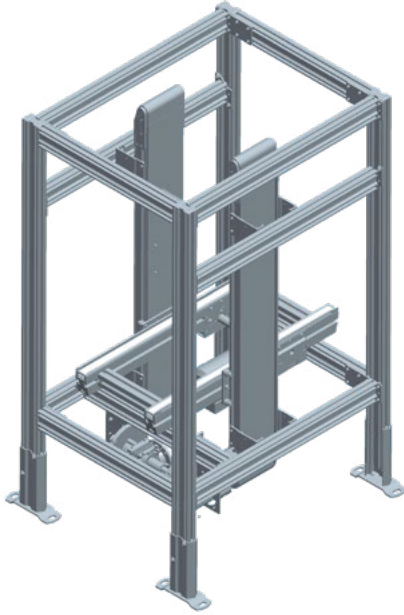

Vertical Transfer Unit (Elevator)

Vertical Transfer Units raise or lower a pallet between two different levels allowing for over/under layouts or transferring pallets over aisles.

- Includes Precision Move conveyor to shuttle pallets in and out of the Vertical Transfer Unit
- Transfers standard and custom pallet sizes
- Up to 91 kg (200 lbs) lift capacity
- Minimum Height TOB: 305 mm (12 in)
- Maximum height TOB 3050 mm (120 in)
- Transfer one or more pallet(s) per cycle
- AC VFD rated gearmotor driven lift and shuttle
- Includes Lexan guarding
- Includes proximity sensor brackets for pallet and lift position detection
- Available as a complete package including automation controls

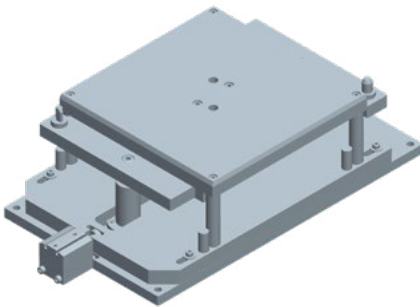

Heavy Duty Lift and Locate

Heavy duty Lift and Locate is used for operations that require large downward force such as pressing or riveting processes. The anvil lifts and mechanically locks in place isolating pressing forces from the conveyor line.

- Withstands up to 2,268 kg (5000 lbs) of downward force
- Available for standard pallet sizes
- Pneumatically operated anvil and locking mechanism
- Isolates pressing forces from the conveyor
- Requires floor mount support by others



Lift Gate

A manually raised and lowered conveyor section to allow access to the conveyor line.

- Available for standard and custom pallet sizes
- Conveyor motor used as the counter weight for easier lifting
- Gas spring controlled pivot mechanism
- Vertical stop position
- Aluminum support structure with T-slot construction and ± 50 mm (2 in) adjustability
- Must be bolted to the floor

Timing Belt Guide

Part Number Reference	Belt Specifications	Tooth Pitch	Thickness	Material	Top Surface	Color	Temperature Range	Maximum Tensile Force	Coefficient of Friction	Width
1D or 1P	Low Friction	10 mm	4.7 mm	Polyamide Fabric Top, Urethane base material, Steel cords	Fabric	Green	-30 to 80° C (-22 to 176° F)	D: 265 lbs (1180 N) P: 132 lbs (590 N)	Very low	25 mm
2D or 2P	Medium Friction	10 mm	4.7 mm	Urethane Top, Urethane base material, Steel cords	Smooth	Off White	-30 to 80° C (-22 to 176° F)	D: 265 lbs (1180 N) P: 132 lbs (590 N)	Medium	25 mm
3D or 3P	Anti-static Low Friction*	10 mm	4.7 mm	Anti-static Fabric Top, Urethane base material, Steel cords	Fabric	Black	-30 to 80° C (-22 to 176° F)	D: 265 lbs (1180 N) P: 132 lbs (590 N)	Very low	25 mm

*Note: Anti-static belts are in full compliance with ISO standard 9563.
D references: Endless Finger Fused Splice. P references: Pinned Splice

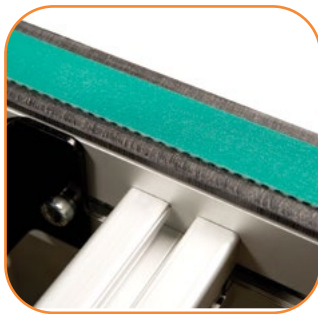

Low Friction



Medium Friction



Anti-Static Low Friction



Pinned Splice

BELT SPEEDS

Determine conveyor belt speed based on the gearmotor RPM in gearmotor tables on pages 53.

Fixed Speed

60 Hz Gearmotors		
Belt Speed		
Gearmotor RPM	m/min	ft/min
29	5.5	18
43	8.2	27
86	16.5	54
173	33	108
345	66	215

Variable Speed

60 Hz Gearmotors		
Belt Speed		
Gearmotor RPM	m/min	ft/min
29	0.6 – 5.5	2 – 18
43	0.8 – 8.2	3 – 27
86	1.7 – 16.5	5 – 54
173	3 – 33	11 – 108
345	6.6 – 66	22 – 215

Note: Due to the wide variety of drive setups and applications, point of installation guarding is the responsibility of the end user.
Note: Dimensions = mm (in)

Standard Load, Fixed Speed

Chart 1 90° eDrive NEMA C-Face														
<ul style="list-style-type: none"> • Sealed gearmotor • NEMA 42 CZ C Face • Totally enclosed, fan cooled • 115V 1 phase includes switch, cord and overload protection • 208-230/460 Volts, 3 phase wiring by others • 60 Hz • Order 3 phase starter separately, see page 41 													Regulatory Approvals 	
Motor Part Number	Gearmotor ref. info		Conveyor Speed			1 Phase			3 Phase			Torque (1ph / 3ph)		3 Phase Starter Chart
	Reference PN	RPM	PN ref.	m/min	ft/min	Hp	kW	FLA 115V	Hp	kW	FLA 208-230/460V	in.-lbs.	Nm	
62MES4(vp)FN	62M060ES4(vp)FN	29	A	5.5	18	0.25	0.19	3.1	0.38	0.28	1.9 / 0.95	124 / 142	16.0 / 16.0	L
	62M040ES4(vp)FN	43	B	8.2	27	0.25	0.19	3.1	0.38	0.28	1.9 / 0.95	159 / 159	18.0 / 18.0	L
	62M020ES4(vp)FN	86	C	16.3	53	0.25	0.19	3.1	0.38	0.28	1.9 / 0.95	121 / 159	13.6 / 18.0	L
	62M010ES4(vp)FN	173	D	32.9	108	0.25	0.19	3.1	0.38	0.28	1.9 / 0.95	80 / 122	9.1 / 13.8	L
	62M005ES4(vp)FN	345	E	65.6	215	0.25	0.19	3.1	0.38	0.28	1.9 / 0.95	41 / 62	4.6 / 7.0	L

Standard Load, Variable Speed

Chart 28 90° eDrive NEMA C-Face VFD Rated														
<ul style="list-style-type: none"> • Sealed gearmotor • NEMA 42 CZ C Face • Totally enclosed, fan cooled • 208-230/460 Volts, 3 phase wiring by others • 10-60 Hz • Order 3 phase starter separately, see page 41 													Regulatory Approvals 	
Motor Part Number	Gearmotor ref. info		Conveyor Speed			3 Phase			Torque (1ph / 3ph)		VFD Controller Chart			
	Reference PN	RPM	PN ref.	m/min	ft/min	Hp	kW	FLA 208-230/460V	in.-lbs.	Nm				
62MES423EN	62M060ES423EN	29	A	3	18	0.9	5.5	0.38	0.28	1.9 / 0.95	142	16.0	D or E	
	62M040ES423EN	43	B	4.5	27	1.4	8.2	0.38	0.28	1.9 / 0.95	159	18.0	D or E	
	62M020ES423EN	86	C	8.8	53	2.7	16.3	0.38	0.28	1.9 / 0.95	159	18.0	D or E	
	62M010ES423EN	173	D	18	108	5.5	32.9	0.38	0.28	1.9 / 0.95	122	13.8	D or E	
	62M005ES423EN	345	E	35.8	215	10.9	65.6	0.38	0.28	1.9 / 0.95	62	7.0	D or E	

FLA = Full Load Amperes

Some motors and gear reducers may normally operate hot to the touch. Consult factory for specific operating temperatures. **Note:** Dimensions = mm (in)

Heavy Load, Fixed Speed

Chart 6 90° eDrive NEMA C-Face

- Sealed gearmotors
- NEMA 56 C face
- Totally enclosed, fan cooled
- 115V 1 phase includes switch, cord and overload protection
- 208-230/460 Volts 3 phase wiring by others
- 60 Hz
- Order 3 phase starter separately, see page 41

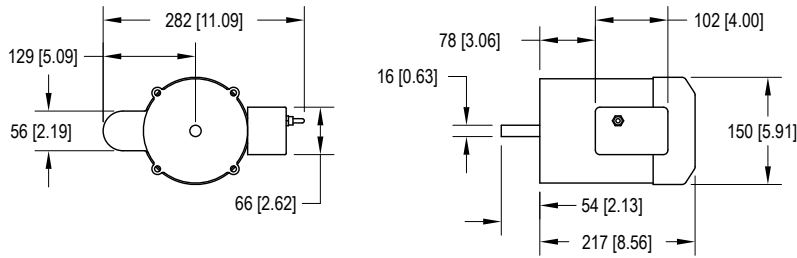

Regulatory Approvals



Motor Part Number	Gearmotor ref. info		Conveyor Speed			1 Phase			3 Phase			Torque (1ph / 3ph)		3 Phase Starter Chart
	Reference PN	RPM	PN ref.	m/min	ft/min	Hp	kW	FLA 115V	Hp	kW	FLA 208-230/460V	in.-lbs.	Nm	
62MEH411FN (1 phase) 32MES423FN (3 phase)	32M060ES4(vp)FN	29	A	5.5	18	0.5	0.37	5.7	0.5	0.37	2.1 - 2 / 1.0	319	36.0	M
	32M040ES4(vp)FN	43	B	8.2	27	0.5	0.37	5.7	0.5	0.37	2.1 - 2 / 1.0	363	41.0	M
	32M020ES4(vp)FN	86	C	16.3	53	0.5	0.37	5.7	0.5	0.37	2.1 - 2 / 1.0	259	29.3	M
	32M010ES4(vp)FN	173	D	32.9	108	0.5	0.37	5.7	0.5	0.37	2.1 - 2 / 1.0	153	17.3	M
	32M005ES4(vp)FN	345	E	65.6	215	0.5	0.37	5.7	0.5	0.37	2.1 - 2 / 1.0	78	8.8	M

Heavy Load, Variable Speed

Chart 10 90° eDrive NEMA C-Face VFD Rated

- Variable frequency drive, 6 - 60 Hz
- Sealed gearmotor
- NEMA 56 C Face
- Totally enclosed, fan cooled
- 230/460 Volts, 3 Phase
- Order controller separately, see page 41

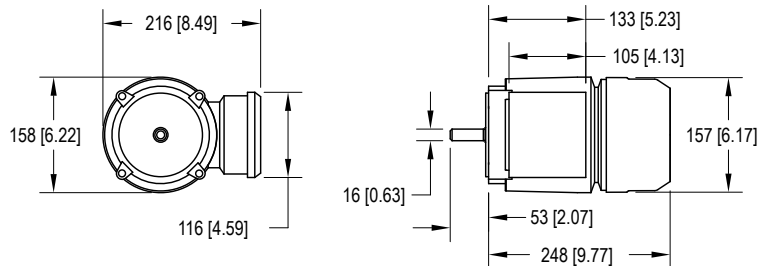

Regulatory Approvals



Motor Part Number	Gearmotor ref. info		Conveyor Speed			3 Phase			*Torque (1ph / 3ph)		VFD Controller Chart		
	Reference PN	RPM	PN ref.	m/min	ft/min	Hp	kW	FLA 208-230/460V	in.-lbs.	Nm			
32MES423EN	32M060ES423EN	29	A	3	18	0.9	5.5	0.75**	0.55	2.6 / 1.3	319	36.0	D or E
	32M040ES423EN	43	B	4.5	27	1.4	8.2	0.75**	0.55	2.6 / 1.3	363	41.0	D or E
	32M020ES423EN	86	C	8.8	53	2.7	16.3	0.75**	0.55	2.6 / 1.3	259	29.3	D or E
	32M010ES423EN	173	D	18	108	5.5	32.9	0.75**	0.55	2.6 / 1.3	153	17.3	D or E
	32M005ES423EN	345	E	35.8	215	10.9	65.6	0.75**	0.55	2.6 / 1.3	78	8.8	D or E

* = At 60 Hz

** = Motor is de-rated to 0.5 Hp (2.2 / 1.1 amp) for full torque throughout the speed range.

FLA = Full Load Amperes

Some motors and gear reducers may normally operate hot to the touch. Consult factory for specific operating temperatures. **Note:** Dimensions = mm (in)

Standard Load, Variable Speed DC

Chart 4 24 Volt Brushless DC

When connecting to the motor via a cable (Plug side view)

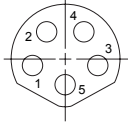

- Brushless 24 VDC Motor
- 350 motor RPM
- 5 pin M8 connector
- Enviroment : -4-122Fo

Pin	Function	Value
1	Power Supply + Input	Rated: 24 VDC, Range: 23 to 28 VDC
2	Rotation Direction (Face Label View)	Counter-Clockwise (CCW): <4 VDC Clockwise (CW): >7 VDC
3	Power Supply - Input (Also Earth Ground)	Ground: 0 VDC
4	Fault Output	Open Collector Vcesat = 0.5 VDC for Ic = 5 mA Vmax = 30 VDC for Icmx = 200 mA Fault: Signal High No Fault: Signal Low
5	Speed Input	Range: 0 - 24 VDC Stop (Braked ZMH): 0 - 2.2 VDC Speed: 2.3 to 10 VDC Max Speed: 10 to 24 VDC

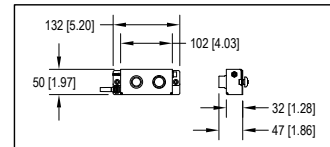
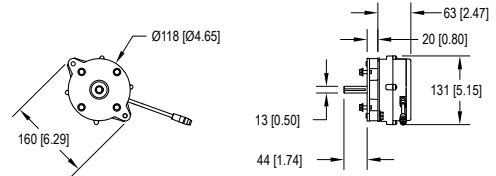

Option D DC Motor Switchbox

Motor Part Number	Gearmotor ref. info		Conveyor Speed				Brushless 24 VDC		Torque (1ph / 3ph)		
	Reference PN	RPM	PN ref.	m/min	ft/min	kW	FLA	in.-lbs.	Nm		
62MESBDDEN(x*)	62M060ESBDDEN(x*)	6	A	0.2	1.1	0.7	3.6	0.06	4.0	142	16.0
	62M040ESBDDEN(x*)	9	B	0.3	1.7	1	5.6	0.06	4.0	159	18.0
	62M020ESBDDEN(x*)	18	C	0.7	3.3	2.3	10.8	0.06	4.0	159	18.0
	62M010ESBDDEN(x*)	35	D	1.3	6.7	4.3	22	0.06	4.0	122	13.8
	62M005ESBDDEN(x*)	70	E	2.7	13.3	8.9	43.6	0.06	4.0	62	7.0

* where x:

C = remote controled, Motor comes with M8 connector only,

D = ready to run, motor comes prewired switch box including switch for FWD/OFF/REV, and varieable speed pot.

R = remotely controlled ON/OFF, motor comes with switch box FWD/OFF/REV, and variable speed pot, and wires to remotely turn on/off via relay or +24VDC signal.

FLA = Full Load Amperes

Some motors and gear reducers may normally operate hot to the touch. Consult factory for specific operating temperatures. **Note:** Dimensions = mm (in)

Variable Speed Controllers

Chart B VFD Controller, Full CE Compliance

- VFD control
- IP 65 enclosure
- EMC filter
- Variable speed
- Mounting hardware
- Line cord and motor cord
- Motor cord only on 400V

Regulatory Approvals
 CE
 cULus

Part Number	Input Volts	Input Phase	Input Hz	Output Volts	Output Phase	Max Kw*	Max Amps	Reversing
62UV2121	230	1	50	230	3	0.75	4.2	Yes
62UV4341	400	3	50	400	3	0.75	2.1	Yes

In order for this drive to meet full CE requirements for European application a separate CE approve RFI filter must be installed. Product shown in chart B above have this filter pre-installed and are recommended for use in the European Union.

Chart D Full Feature VFD Controller

- Full feature VFD control
- NEMA 4 enclosure
- Digital display
- Keypad with Start/Stop, Forward/Reverse and speed variations
- Includes cord to motor
- Power to controller by others for 230V & 460V input
- 62MV1122 includes line cord to controller
- Mounting hardware

Regulatory Approvals
 CE
 cULus

Part Number	Input Volts	Input Phase	Input Hz	Output Volts	Output Phase	Max Kw*	Max Amps	Reversing
32MV1122	115	1	60	230	3	0.5	2.2	Yes
32MV2122	230	1	60	230	3	0.5	2.2	Yes
32MV1121	115	1	60	230	3	1.0	4.0	Yes
32MV2121	230	1	60	230	3	1.0	4.0	Yes
32MV2322	230	3	60	230	3	0.5	2.2	Yes
32MV4341	460	3	60	460	3	1.0	2.0	Yes

In order for this drive to meet full CE requirements for European application a separate CE approve RFI filter must be installed. Product shown in chart B above have this filter pre-installed and are recommended for use in the European Union.

Chart E Basic VFD Controller

- Variable Speed Drive
- On/off buttons and knob for speed on keypad
- Direction setting via parameter change
- Includes mounting bracket that can mount drive to vertical or horizontal T-slot
- Includes 10ft input power cord with three prong standard 120V outlet plug
- Includes 10ft motor output cord for 3 phase motor connection with flying leads
- IP 20 rating with electrical finger safe connections
- Pre-programmed to match motor parameters and locked parameter settings for ease of uses
- cULus and CE compliant

Regulatory Approvals
 CE
 RoHS
 cULus

Part Number	Input Volts	Input Phase	Input Hz	Output Volts	Output Phase	Max Hp	Max Amps	Reversing
22MV1126T	115	1	60	230	3	0.125-0.5	2.6	Yes*

*Reversing is controlled by parameter change

* = See FLA from motor charts

Note: Due to the wide variety of drive setups and applications, point of installation guarding is the responsibility of the end user.
Note: Dimensions = mm (in)

Manual Motor Starters

Manual motor starts are manual electronic disconnects that provide motor overload protection and are required by the National Electric Code (NEC) for safe motor operation.

- IP 55 Enclosure
- Push button Start / Stop
- Includes mounting hardware

Regulatory Approvals



Illustration A

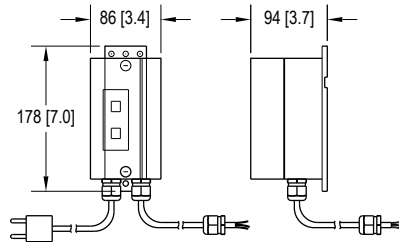

Illustration B

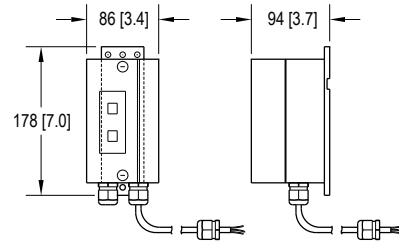

Chart I		230/400V 50Hz to 2.5 amp		
<ul style="list-style-type: none"> • 230 Volts, 1 phase includes cord, plug and starter • 230/400 Volts, 3 phase wiring to starter by others • Wiring between motor and starter provided when ordered together • 50 Hz 				
Part Number	In Volts	In Phase	Amp Range	Illustration
62(c)M21T	230	1	1.6 - 2.5	A
62(c)M23T	230	3	1.0 - 1.6	B
62(c)M43T	400	3	0.63 - 1.0	B

Chart J		230/400V 50 Hz to 4 amp		
<ul style="list-style-type: none"> • 230 Volts, 1 phase includes cord, plug and starter • 230/400V, 3 phase wiring to starter by others • Wiring between motor and starter provided when ordered together • 50 Hz 				
Part Number	In Volts	In Phase	Amp Range	Illustration
62(c)M21J	230	1	2.5 - 4.0	A
62(c)M23J	230	3	1.6 - 2.5	B
62(c)M43J	400	3	1.0 - 1.6	B

Chart L		230/460V 60 Hz to 1.6 amp		
<ul style="list-style-type: none"> • 230/460 Volts, 3 phase wiring to starter by others • Wiring between motor and starter provided when ordered together • 60 Hz 				
Part Number	In Volts	In Phase	Amp Range	Illustration
62MM23L	230	3	1.0 - 1.6	B
62MM43L	460	3	0.4 - .63	B

Chart M		230/460V 60Hz to 2.5 amp		
<ul style="list-style-type: none"> • 230/460 Volts, 3 phase wiring to starter by others • Wiring between motor and starter provided when ordered together • 60 Hz 				
Part Number	In Volts	In Phase	Amp Range	Illustration
62MM23M	208 -230	3	1.6 - 2.5	B
62MM43M	460	3	1.0 - 1.6	B



Fixed Height Support Stands

- Standard 2-Leg version for base conveyor mounting
- 305 mm (12 in) minimum TOB height
- 1829 mm (72 in) maximum TOB height
- Aluminum construction with T-Slot mounting for bolt on accessories and structure
- Provide ± 50 mm (2 in) of adjustment
- Optional diagonal brace, see page 44.

Stand Chart			
Stand Width	140 mm	5 mm increments up to...	800 mm
Part Number Reference	140	05 increments up to...	800

Stand Chart			
Stand Height	305-406 mm (12-16 in)	1 in increments up to...	1727-1829 mm (68 - 72 in)
Part Number Reference	1216	0101 increments up to..	6872

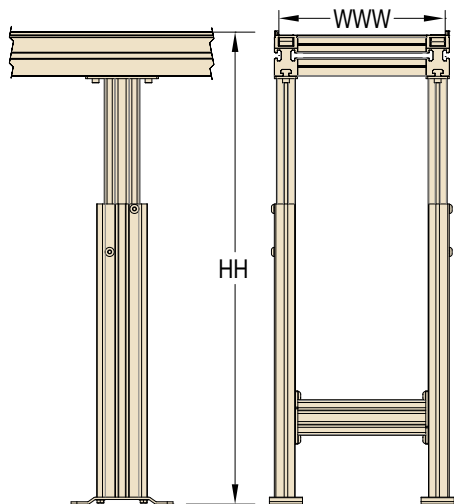

DualMove Series Pallet System Stands						
D S 2	2	M	WWW	-	LH	UH F
						Footing: F = Fixed Foot
						Tallest Height to TOB (in inches)
						Lowest Height to TOB (in inches)
						Conveyor Width Reference: 140 - 800 mm in 5 mm increments
						Documentation Language: M = US-English
						Post Type: 2 = 2 Leg Stand

Note: Due to the wide variety of conveyor and stand options along with possible configurations, stability of the final setup is the responsibility of the end user. **Note:** Due to the wide variety of drive setups and applications, point of installation guarding is the responsibility of the end user. **Note:** Dimensions = mm (in)

Diagonal Bracing



Specifications

- For use on steel, aluminum and single post support stands with casters
- Metric fastener mounting hardware included
- For use on all stands with casters and any stands over 1829 mm (72 in) tall
- One brace per stand for conveyors up to 610 mm (24 in) wide
- Two braces per stand for conveyors over 610 mm (24 in) wide

Part Number	Description
39MB-TS	for stands up to 762 mm (30 in) tall
39MB-TT	for stands over 762 mm (30 in) tall

Pallet Sensor Bracket, Vertical



Specifications

- Standard mounting for 12 mm barrel proximity sensors
- Sensor faces upward sensing pallet pick-up on bottom of pallet
- Requires a minimum of 1 in long threaded portion on sensor
- Includes all mounting hardware
- Proximity sensor with 4 mm sensory range recommended

Part Number	205575
-------------	--------

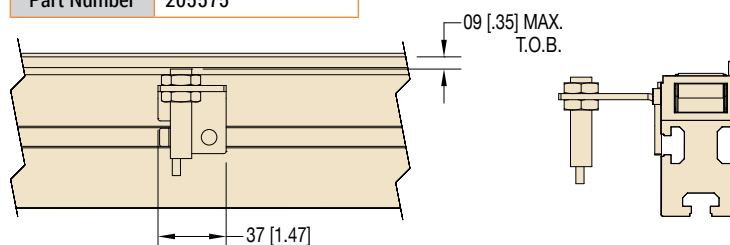

Pallet Sensor Bracket, Horizontal



Specifications

- Standard mounting for 12 mm barrel proximity sensors
- Sensor faces inward sensing pallet pick-up on outside of pallet
- Requires a minimum of 1 in long threaded portion on sensor
- Includes all mounting hardware
- Not for use on pallet sides with bumpers
- Proximity sensor with 4 mm sensory range recommended

Part Number	205574
-------------	--------

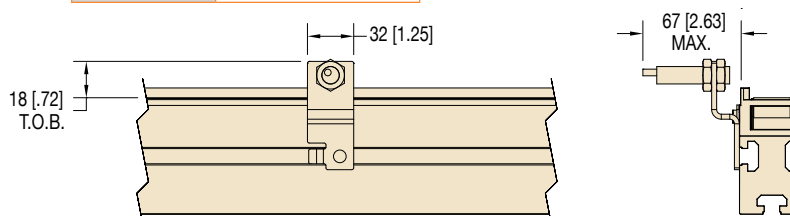

Photo Sensor Bracket



Specifications

- Standard mounting for 18 mm barrel / nose mount reflective sensors
- Adjustable in height and angle
- Includes a reflector
- Includes all mounting hardware

Part Number	Photo Eye Mount Type
75M-PM-1	Reflective
75M-PM-3	Through Beam
75M-PM-5	Convergence

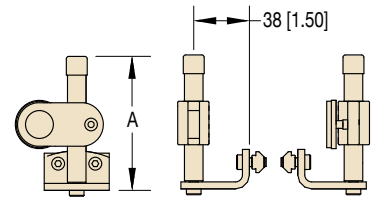

A = 92 [3.61 in] for 50 mm [2 in] Adjustment

Side Tables



Specifications

- Provides a 152 mm (6 in) or 305 mm (12 in) wide working surface
- Adjusts in/out and up/down
- Can be positioned anywhere along the conveyor
- Anodized aluminum work surface
- Max load: 6 kg/m (5 lbs/ft), use Adjustable Tie Brackets for added capacity
- Available in 305 mm (1 ft) increments from 305 mm (1 ft) to 30,175 mm (99 ft)

Side Tables

27MSF T - 06 LLLL

- Table Length (ex. 0200 = 2 ft)

- Table Width: 06 = 6 in 12 = 12 in

- Conveyor / Table Type:

1 = One Side

2 = Two Sides

Example: 27MSF1-060200

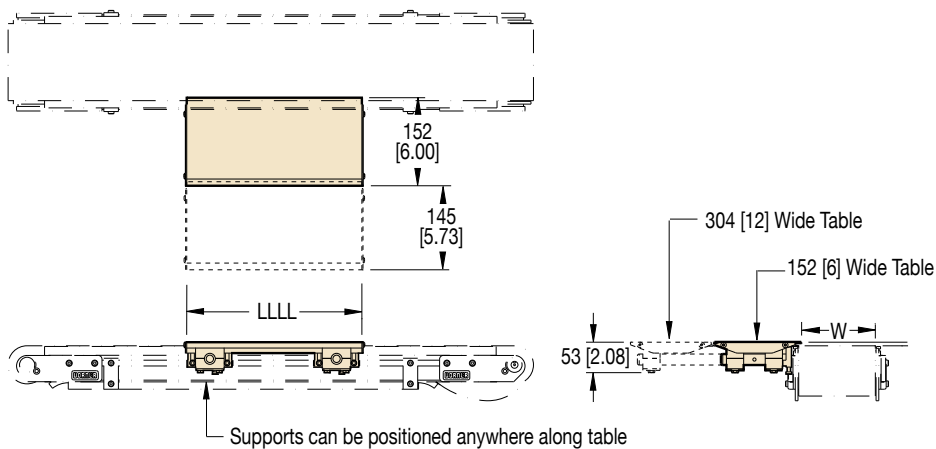

LLLL = 305 to 30,175 mm (1 to 99 ft), Maximum 2438 mm (8 ft) length single piece

T-Slot Accessories

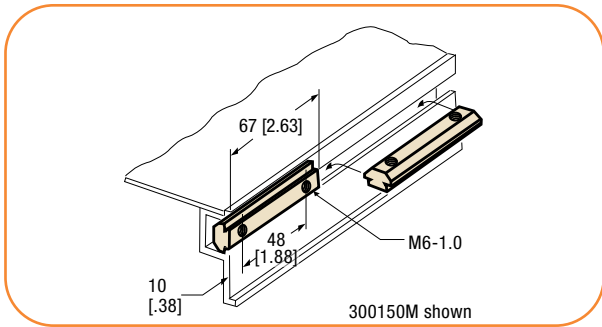

T-Bars

- Mounts in T-Slot to attach heavy accessories
- Fits conveyor and stands

Part Number	639971M (1 hole T-bar, M6-1.0, .75 in long) 202390M (1 hole T-bar, M8-1.25, .63 in long) 643874M (.75 in centers, 2 hole T-bar, M6-1.0, 1.5 in long) 200626M (.875 in centers, 2 hole T-bar, M6-1.0, 1.62 in long) 200830M (1.0 in centers, 2 hole T-bar, M6-1.0, 1.75 in long) 639717M (1.25 in centers, 2 hole T-bar, M6-1.0, 2.0 in long) 300150M (1.875 in centers, 2 hole T-bar, M6-1.0, 2.62 in long) 300536M (2.125 in centers, 2 hole T-bar, M6-1.0, 2.88 in long)
-------------	-------------------------------------------------------------------------------------------------------------------------------------------------------------------------------------------------------------------------------------------------------------------------------------------------------------------------------------------------------------------------------------------------------------------------------------------------------------------------------------------------

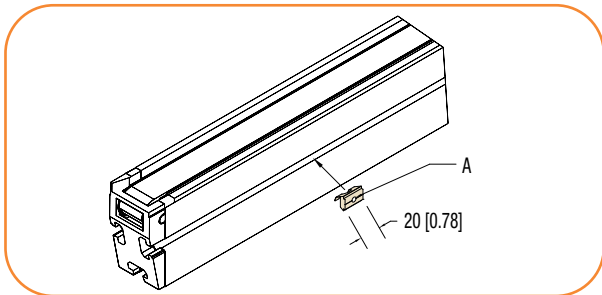

Spring Nuts

- For mounting accessories to conveyor
- Spring retains position in T-Slot
- 20 mm (.78 in) long

Part Number	205504 M4 x .7 205505 M5 x .8 205506 M6 x 1.0 205508 M8 x 1.25
-------------	-------------------------------------------------------------------------

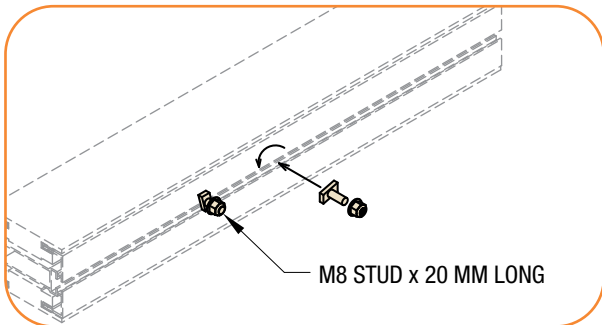

T-Bolt Hardware

- For mounting accessories to conveyor
- Twist in T-Bolt for mounting accessories
- M8-1.25 male threaded post
- (2) lengths available; 20 mm long and 35 mm long
- 20mm long used to mount up to 0.25 in plate thickness
- 35mm long used to mount up to 0.85 in plate thickness
- Provided in a package of 5 T-Bolts and flanged locknuts

Part Number	203446 (20 mm long) 203447 (35 mm long)
-------------	--------------------------------------------

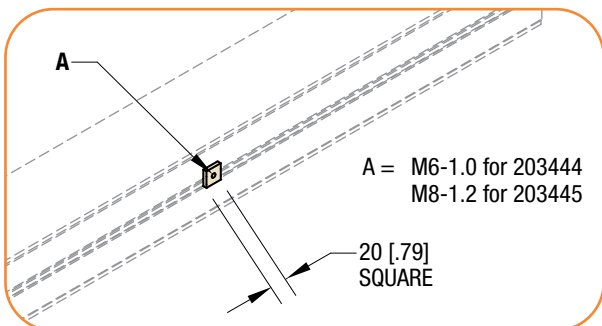

Slide In Square Nuts

- For mounting accessories to conveyor
- Must be slid in at section break
- (2) thread sizes available: M6-1.0 or M8-1.25
- Provided in a package of 5 nuts

Part Number	203444 (M6-1.0) 203445 (M8-1.25)
-------------	-------------------------------------

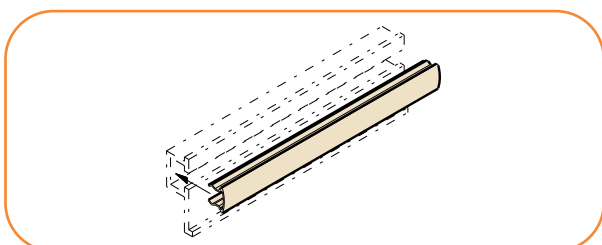

T-Slot Cover

- Snaps into conveyor and aluminum stand T-Slots
- Black plastic extrusion
- Can be trimmed to fit

Part Number	645656P (Per 305 mm (1 ft) of length)
-------------	---------------------------------------

Regulatory Approvals:







Conveyors:

All Dorner DualMove Pallet Systems standard conveyors (not including gearmotors and controllers) are CE approved. CE approval follows the provisions of the following directives; Machine Directive 2006/42/EC, EU Low Voltage Directive 2006/95/EC, and EMC Directive 2004/108/EC. All conveyors are marked with the CE symbol on the Dorner serial number tag located on the conveyor frame. Contact the factory for the CE Declaration of Conformity.

All Dorner DualMove Pallet Systems standard conveyors (not including gearmotors and controllers) are designed and manufactured in accordance with the restrictions defined in the "Restriction of Hazardous Substances" directive, citation 2002/95/EC, commonly known as RoHS. All conveyors are marked with the RoHS symbols on the Dorner serial number tag located on the conveyor frame.

Gearmotors and Controllers:

All Dorner DualMove Pallet Systems gearmotors and controllers carry one or more of the following approvals. Products are not covered by each approval. Please see the appropriate part number on the Gearmotor and controller charts located in this manual. In addition, regulatory symbols are located on the product information tags located on the product.

	<p>CE marking on a product is a manufacturer's declaration that the product complies with the essential requirements of the relevant European health, safety and environmental protection legislation, in practice by the Product Directives. CE Marking on a product ensures the free movement of the product within the European Union (EU).</p>
	<p>This directive restricts (with exceptions) the use of six hazardous materials in the manufacture of various types of electronic and electrical equipment. It is closely linked with the Waste Electrical and Electronic Equipment Directive (WEEE) 2002/96/EC which sets collection, recycling and recovery targets for electrical goods and is part of a legislative initiative to solve the problem of huge amounts of toxic e-waste.</p>
	<p>The UL Recognized Component mark is for products intended to be installed in another device, system or end product. This Recognized Component Mark is for the United States only. When a complete product or system containing UL Recognized Components is evaluated, the end-product evaluation process can be streamlined.</p>
	<p>The UL Recognized Component mark is for products intended to be installed in another device, system or end product. This Recognized Component Mark is for the United States and Canada. When a complete product or system containing UL Recognized Components is evaluated, the end-product evaluation process can be streamlined.</p>
	<p>CSA International (Canadian Standards Association), is a provider of product testing and certification services for electrical, mechanical, plumbing, gas and a variety of other products. Recognized in the U.S., Canada and around the world, CSA certification marks indicate that a product, process or service has been tested to a Canadian or U.S. standard and it meets the requirements of an applicable CSA standard or another recognized document used as a basis for certification.</p>
	<p>The UL Listing Mark means UL found that representative product samples met UL's safety requirements. These requirements are primarily based on UL's own published standards for safety. The C-UL-US Mark indicates compliance with both Canadian and U.S. requirements. The products with this type of Mark have been evaluated to Canadian safety requirements and U.S. safety requirements.</p>

Belting Chemical Resistance:

Belting:

The following is a list of the top coat materials used in DualMove Conveyor belting:

Material	Belt Number
Urethane	1D, 2D, 6D

Resistance to Materials: Belting

The following table provides the resistance to belt materials used in the conveyor to several chemicals. Application testing is recommended to determine long term material durability.

Legend: 1 = Good resistance | 3 = Limited resistance | 4 = Not recommended

Materials	Urethane	Materials	Urethane	Materials	Urethane
Chemicals		Calcium chloride	1	Ethyl alcohol, non-denatured 96%	1
Acetic acid (glacial acetic acid)	4	Calcium nitrate	1	Ethyl alcohol, non-denatured 50%	1
Acetic acid 10 %	3	Calcium sulphate	1	Ethyl alcohol, non-denatured 10%	1
Acetic anhydride	3	Carbon disulphide	4	Ethyl benzene	4
Acetone	4	Carbon tetrachloride	3	Ethyl chloride	4
Aluminum salts	1	Chlorine, liquid	4	Ethylene chloride	4
Alum	1	Chlorine, gaseous, dry	4	2-Ethyl hexanol	1
Ammonia, aqueous	3	Chlorine, gaseous, wet	4	Formaldehyde	1
Ammonia, gaseous	1	Chlorine water	4	Formic acid, dilute	4
Ammonium acetate	1	Chlorobenzene	4	Glycerine	1
Ammonium carbonate	1	Chloroform	4	Glycerine, aqueous	1
Ammonium chloride	1	Chlorosulphonic acid	4	Glycol	1
Ammonium nitrate	1	Chromic acid	4	Glycol, aqueous	1
Ammonium phosphate	1	Chromium salts	1	Heptane	1
Ammonium sulphate	1	Chromium trioxide	1	Hexane	1
Amyl alcohol	1	Citric acid	4	Hydrochloric acid, conc.	3
Aniline	3	Copper salts	1	Hydrochloric acid 10 %	3
Barium salts	1	Cresols	3	Hydrofluoric acid 40 %	4
Benzaldehyde	4	Cresols, aqueous	3	Hydrogen chloride, gaseous, dilute	3
Benzene (see also Motor fuels)	1	Cyclohexane	4	Hydrogen chloride, gaseous, conc.	3
Benzoic acid	1	Cyclohexanol	4	Hydrogen peroxide 10%	3
Benzol	3	Cyclohexanone	4	Hydrogen sulphide	3
Boric acid	1	Decahydronaphthalene	4	Iron salts (sulphate)	1
Boric acid, solution	1	Dibutyl phthalate	3	Isooctane	1
Bromine	4	Diethyl ether	4	Isopropyl alcohol	1
Bromine water	4	Dimethyl formamide	4	Lactic acid	1
Butane, gaseous	1	1,4 Dioxan	4	Magnesium salts	1
Butane, liquid	1	Ether	4	Mercury	1
Butyl acetate	4	Ethyl acetate	4	Mercury salts	1
n-Butyl alcohol	1	Ethyl alcohol, non-denatured 100%	1	Methyl alcohol, aqueous 50 %	3

Resistance to Materials: Belting

The following table provides the resistance to belt materials used in the conveyor to several chemicals. Application testing is recommended to determine long term material durability.

Legend: 1 = Good resistance | 3 = Limited resistance | 4 = Not recommended

Materials	Urethane	Materials	Urethane	Materials	Urethane
Methyl alcohol (methanol)	1	Sodium chlorate	1	Benzene	1
Methyl ethyl ketone	4	Sodium chloride (common salt)	1	Bleaching lye (12.5%)	1
Methylene chloride	4	Sodium hydroxide (caustic soda)	4	Bone oil	1
Naphthalene	3	Sodium hypochlorite	1	Borax	1
Nickel salts	1	Sodium nitrate	1	Brake fluid* Bosch	1
Nitric acid	4	Sodium nitrite	1	Brake fluid* Skydrol	4
Nitrobenzene	4	Sodium perborate	1	Chloride of lime (aqueous suspension)	1
Octane (see also isooctane)	1	Sodium phosphate	1	Chlorine (active)	4
Oleic acid	1	Sodium sulphate (Glauber salt)	1	Chrome baths* (technical)	1
Oxalic acid	1	Sodium sulphide	1	Chromosulphuric acid	4
Ozone	1	Sodium sulphite	1	Cresol solution	3
Perchloroethylene	4	Sodium thiosulphate (fixing salt)	1	Diesel oil	1
Phenol	3	Stearic acid	1	Fertilizer salts	1
Phenol, aqueous	4	Succinic acid	1	Fixing salt	1
Phosphoric acid 85 %	4	Sulphur	1	Floor wax	1
Phosphoric acid 50 %	1	Sulphur dioxide	3	Formalin	1
Phosphoric acid 10 %	1	Sulphuric acid 96%	4	Fuel oils*	1
Phosphorus pentoxide	1	Sulphuric acid 50%	4	Furniture polish*	1
Potash lye 50 %	4	Sulphuric acid 25%	4	Gypsum	1
Potash lye 25 %	4	Sulphuric acid 10%	4	Ink*	1
Potash lye 10 %	4	Tartaric acids	1	Linseed oil	1
Potassium carbonate (potash)	1	Tetrachloroethane	4	Litex (styrene)	4
Potassium chlorate	1	Tetrachloroethylene (perchloroethylene)	4	Mineral oils (non-aromatic)	1
Potassium chloride	1	Tetrahydrofuran	4	Moth balls	3
Potassium dichromate	1	Tetrahydronaphthalene	4	Diesel oil*	1
Potassium iodide	1	Thiophene	4	Petrol (gasoline) DIN51635	1
Potassium nitrate	1	Tin II chlorides	1	Petrol, regular	1
Potassium permanganate	1	Toluene	4	Petrol, super	3
Potassium persulphate	1	Trichloroethylene	4	Motor oils*	1
Potassium sulphate	1	Urea, aqueous	1	Oil no. 3 (ASTM)	1
Propane, gaseous	1	Water	1	Oleum	4
Propane, liquid	1	Xylene	4	Paraffin	1
Pyridine	4	Zinc salts	1	Paraffin oil	1
Silver salts	1			Petroleum	1
Soda lye 50% (see potash lye)	4	Products		Petroleum ether	1
Soda lye 25%	4	Alum	1	Photographic developer	1
Soda lye 10%	4	Anti-freeze*	1		
Sodium bisulphite	1	Aqua regia	4		
Sodium carbonate (natron)	1	Asphalt	1		
Sodium carbonate (soda)	1	Battery acid	4		

Conveyor Noise Level (Decibel Ratings)

The actual noise level generated by the conveyor depends on several factors: the installation configuration, the product running on the conveyor, the surrounding equipment, the conveyor options and belt speed. The noise level generated by the conveyor is typically less than the general noise level of factory equipment.

Generally a higher belt speed will result in a higher noise level. In addition modular belt conveyors will run slightly louder than belted conveyors. The following charts provide basic decibel ratings for a typical conveyor arrangements.

DualMove Strand Conveyors:

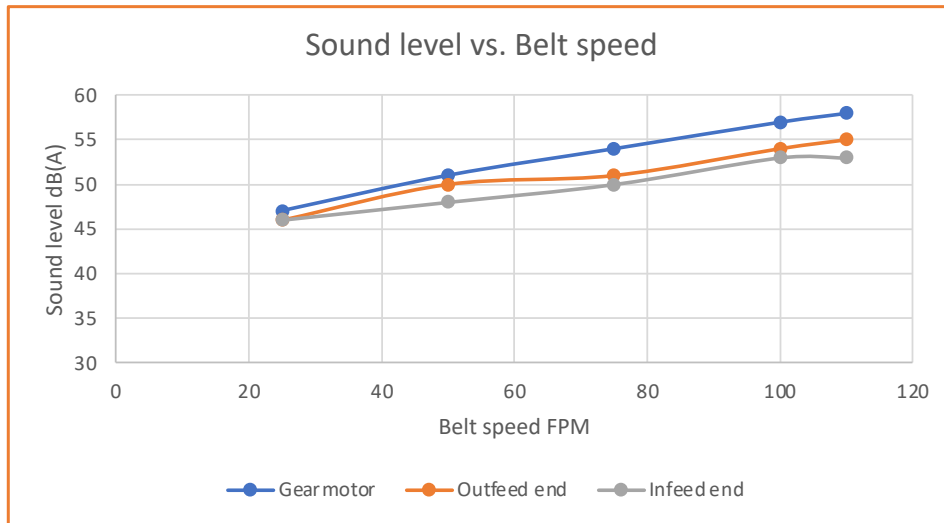

Belting and Coefficient of Friction

The coefficient of friction is used to determine the load a conveyor can carry. It affects a conveyor in two ways: the friction that exists between the conveyor belt and the bed surface, and if accumulating product the friction that exists between the conveyor top surface and the product.

Coefficient of Friction, between the bottom of the conveyor belt and bed surface			
Product	Surfaces	Application Condition	Coefficient of Friction
DualMove Strand Conveyor	Impregnated polyester fabric to plastic bed plate	Dry	0.30

Coefficient of Friction, between the top surface of conveyor belt and product:

DualMove Conveyors		
The following table provides the coefficient of friction between steel product and various belt top surfaces. All factors below are assuming dry conditions.		
Belt Number	Top Surface Material and Type	Coefficient of Friction
2D	Smooth medium urethane	0.50
1D, 6D	Impregnated polyester fabric	0.20

Lift & Transfer Pallet Stop Configurations

		Non-Cushioned	Cushioned
End Stop	Sending		
	Receiving		
Pass Thru	Sending		
	Receiving		

Calculating Conveyor Belt Speed

DualMove Conveyors:

To calculate the conveyor belt speed you need to know the following factors:

- Drive roller diameter
 - 60.60 mm (2.386 in) pitch diameter
- RPM of gearmotor

$$\text{Belt Speed (ft/min)} = (\text{Drive roller diameter}/12) \times (3.14) \times (\text{RPM of gearmotor})$$

Example:

DualMove Pallet Conveyor and the gearmotor. The gearmotor is a 10:1 ratio with 173 rpm output.

$$\text{Belt Speed (ft/min)} = (2.386/12) \times (3.14) \times (173)$$

$$\text{Belt speed (ft/min)} = 108 \text{ ft/min}$$

Calculating Conveyor Load Capacity

There are several factor that effect the overall conveyor load of the DualMove conveyor. These include:

- Conveyor size and configuration
- Conveyor speed
- Application temperature
- Product Accumulation
- Number of starts and stops per hour

Located online at www.dornerconveyors.com is the Dorner conveyor configuration tool, DTools. This tool allows you to configure your conveyor layout and determine the maximum load capacity for the conveyor. It is suggested that this program be used to calculate the conveyor load as the calculation is quite complicated. This configuration program however does not take into account temperature, dirty conditions, and conveyor starts and stops. If these conditions are part of your application please use the load reducing factors as shown below.

$$\text{Maximum Load} = (\text{Load from DTools})(\text{Temperature Factor})(\text{Start/Stop Factor})$$

Temperature Factor		
Ambient temperature can negatively affect the capacity of the conveyor.		
Temperature F	Temperature C	Temperature Factor
-4	-20	1.0
32	0	1.0
68	20	1.0
104	40	0.9
140	60	0.8

Start / Stop Factor	
Frequent Start / Stops of the conveyor can negatively affect the capacity of the conveyor. All start / stop applications must use a soft start mechanism such as a Frequency Inverter with a 1 second acceleration cycle.	
Application Condition	Start / Stop Factor
Continuous Run or 1 start/stop per hour	1.0
Maximum 10 starts/stop per hour	0.83
Maximum 30 starts/stop per hour	0.70
Greater than 30 starts/stop per hour	0.62

Pallet Weights (lbs)

Pallet					
Pallet Width (mm)	Pallet Length (mm)	1/4 in Alum Plate	1/2 in Alum Plate	3/16 in Steel Plate	3/8 in Alum Plate
160	160	1.1 (2.3)	1.5 (3.3)	1.6 (3.5)	1.1 (2.5)
160	240	1.3 (2.9)	1.9 (4.3)	2.1 (4.6)	1.6 (3.4)
240	240	1.7 (3.7)	2.6 (5.8)	2.8 (6.2)	2.1 (4.7)
240	320	2 (4.5)	3.3 (7.4)	3.6 (7.9)	2.7 (5.9)
240	480	2.7 (6.1)	4.7 (10.4)	5.1 (11.2)	3.8 (8.3)
320	320	2.5 (5.5)	4.3 (9.4)	4.6 (10.1)	3.5 (7.6)
320	480	3.5 (7.6)	6.1 (13.5)	6.6 (14.5)	4.9 (10.8)
400	400	3.6 (7.9)	6.3 (14)	6.8 (15.1)	5.1 (11.2)
400	480	4.2 (9.2)	7.5 (16.5)	8.1 (17.9)	6 (13.1)
480	480	4.9 (10.8)	8.9 (19.6)	9.6 (21.2)	7 (15.4)
640	480	6.4 (14)	11.6 (25.7)	12.6 (27.8)	9.1 (20)
640	640	8.3 (18.3)	15.3 (33.8)	16.7 (36.7)	11.8 (26)
640	800	10.2 (22.5)	19 (42)	20.7 (45.6)	14.5 (32.1)
800	640	10.2 (22.5)	19 (42)	20.7 (45.6)	14.5 (32.1)
800	800	12.6 (27.8)	23.6 (52.1)	25.7 (56.7)	18 (39.7)

DualMove Pallet System Modules

Pneumatic Specifications									
Devise	Pallet Width / Devise Size	Action	Bore Diameter	Stroke	Return Type	Force per Psi	Sensor Compatible	Fitting Tap Size	Fitting Tube Size
Lift and Locate	160-240 mm	Lift Cylinder	40 mm (1.57in)	40 mm (1.57 in)	Pneumatic	1.9	Yes	1/8 NPT	6 mm (1/4 in)
	320-480 mm	Lift Cylinder	63 mm (2.5 in)	50 mm (1.97 in)	Pneumatic	4.9	Yes	1/4 NPT	6 mm (1/4 in)
	640-800 mm	Lift Cylinder	80 mm (3.15 in)	50 mm (1.97 in)	Pneumatic	7.8	Yes	3/8 NPT	6 mm (1/4 in)
Lift and Transfer	160-240 mm	Lift Cylinder	50 mm (1.97 in)	35 mm (1.38 in)	Pneumatic	3.0	Yes	1/4 NPT	6 mm (1/4 in)
	320-480 mm	Lift Cylinder	80 mm (3.15 in)	35 mm (1.38 in)	Pneumatic	7.8	Yes	3/8 NPT	6 mm (1/4 in)
	640-800 mm + (480 x 640L)	Lift Cylinder	80 mm (3.15 in)	50 mm (1.97 in)	Pneumatic	7.8	Yes	3/8 NPT	6 mm (1/4 in)
Lift and Rotate	160-240 mm	Lift Cylinder	50 mm (1.97 in)	35 mm (1.38 in)	Pneumatic	3.0	Yes	1/4 NPT	6 mm (1/4 in)
		Rotate Cylinder	30 mm (1.18 in)	N/A	Pneumatic	N/A	Yes	1/8 NPT	6 mm (1/4 in)
	320-480 mm	Lift Cylinder	80 mm (3.15 in)	35 mm (1.38 in)	Pneumatic	7.8	Yes	3/8 NPT	6 mm (1/4 in)
		Rotate Cylinder	50mm (1.97 in)	N/A	Pneumatic	N/A	Yes	1/8 NPT	6 mm (1/4 in)
	640-800 mm	Lift Cylinder	80 mm (3.15 in)	50 mm (1.97 in)	Pneumatic	7.8	Yes	3/8 NPT	6 mm (1/4 in)
		Rotate Cylinder	100 mm (3.94 in)	N/A	Pneumatic	N/A	Yes	1/8 NPT	6 mm (1/4 in)
Corner and Merge	160-320mm	Lift Cylinder (3x each)	27 mm (1.06 in)	13 mm (0.50 in)	Pneumatic	0.9	Yes	1/8 NPT	6 mm (1/4 in)
Cushion Stop	Standard	Stop Retract	35 mm (1.38 in)	9 mm (0.35 in)	Spring	N/A	No	M5	6 mm (1/4 in)
	Heavy							G 1/8	
Non-Cushion Stop	Standard	Stop Retract	35 mm (1.38 in)	9 mm (0.35 in)	Spring	N/A	No	M5	6 mm (1/4 in)
	Heavy							G 1/8	

DualMove Pallet System Module Spacing

Pallet Stop to Lift & Locate

Pallet Length L (mm)	Minimum Distance D1	Minimum Distance D2
160	82 (3.23)	240 (9.45)
240	122 (4.8)	320 (12.6)
320	162 (6.38)	400 (15.75)
400	202 (7.95)	480 (18.9)
480	242 (9.53)	560 (22.05)
640	322 (12.68)	720 (28.35)
800	402 (15.83)	880 (34.65)

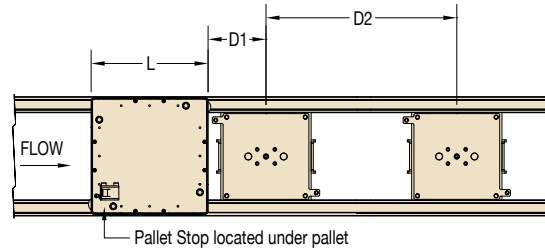

Pallet Stop to Lift & Transfer

Pallet Length L (mm)	Minimum Distance D1	Minimum Distance D2 Hardstop	Minimum Distance D2 Cushion
160	99 (3.90)	283 (11.15)	283 (11.15)
240	139 (5.47)	291 (11.45)	291 (11.45)
320	179 (7.05)	371 (14.60)	371 (14.60)
400	247 (9.72)	575 (22.64)	575 (22.64)
480	259 (10.20)	531 (20.90)	531 (20.90)
640	369 (14.53)	736 (28.98)	736 (28.98)
800	449 (17.68)	896 (35.28)	896 (35.28)

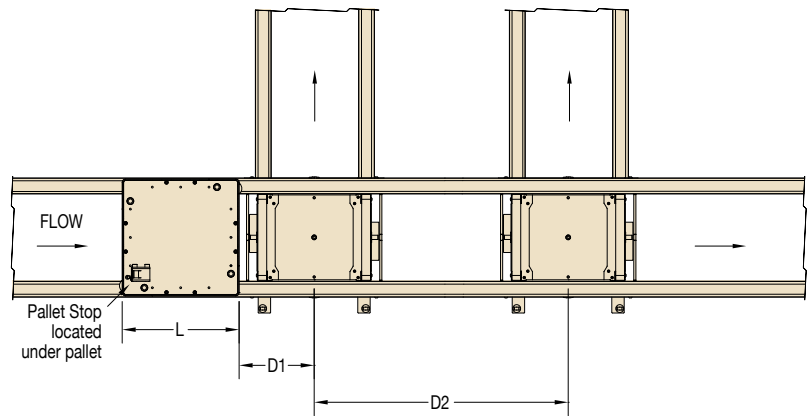

Parallel Conveyors with 90 Degree Corners

Pallet Width W (mm)	Minimum Parallel Center Line X	Minimum Conveyor Length Y
160	849 (33.42)	660 (25.99)
240	929 (36.57)	660 (25.99)
320	1009 (39.72)	660 (25.99)
400	1089 (42.87)	660 (25.99)
480	1169 (46.02)	660 (25.99)
640	1329 (52.32)	660 (25.99)
800	1489 (58.62)	660 (25.99)

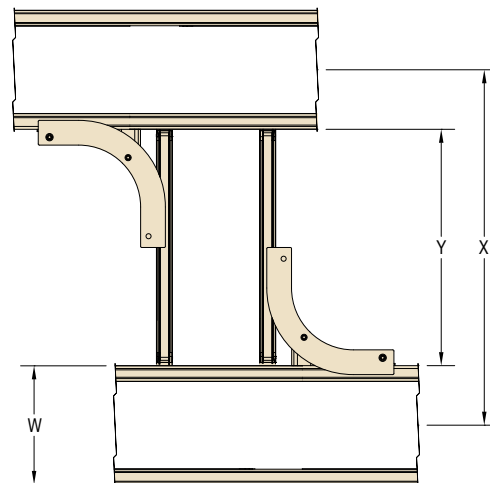

Note: Dimensions = mm (in)

DualMove Pallet System Module Spacing *Continued*

Lift and Locate after 90 Degree Corner or Merge

Pallet Width W (mm)	Minimum Distance L
160	504 (19.84)
240	584 (22.99)
320	664 (26.14)

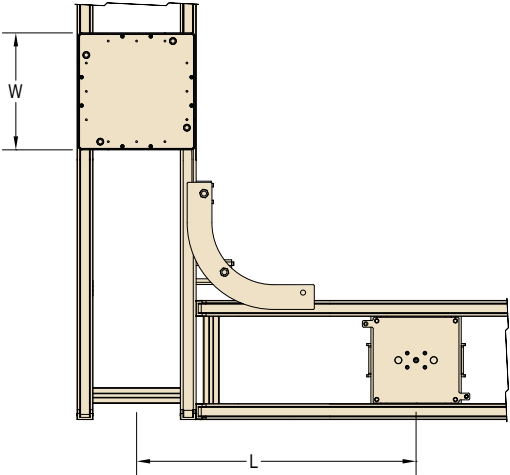

Multiple 90 Degree Corners and Merge

Pallet Width W (mm)	Minimum Distance X
160	514 (20.24)
240	594 (23.39)
320	674 (26.54)

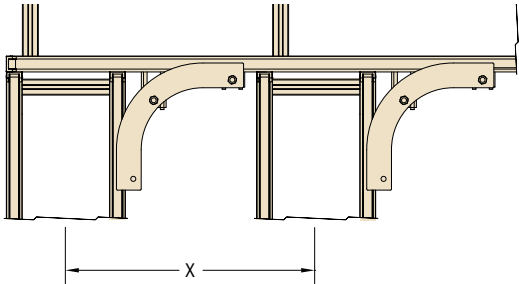

Note: Dimensions = mm (in)

DualMove Pallet System Module Spacing *Continued*

Heavy Load Corner – 90 Degree		
Pallet Width W (mm)	X	Y
320	1112 (43.8)	752 (29.6)
400	1192 (46.9)	792 (31.2)
480	1272 (50.1)	832 (32.8)
640	1432 (56.4)	912 (35.9)
800	1592 (62.7)	992 (39.1)

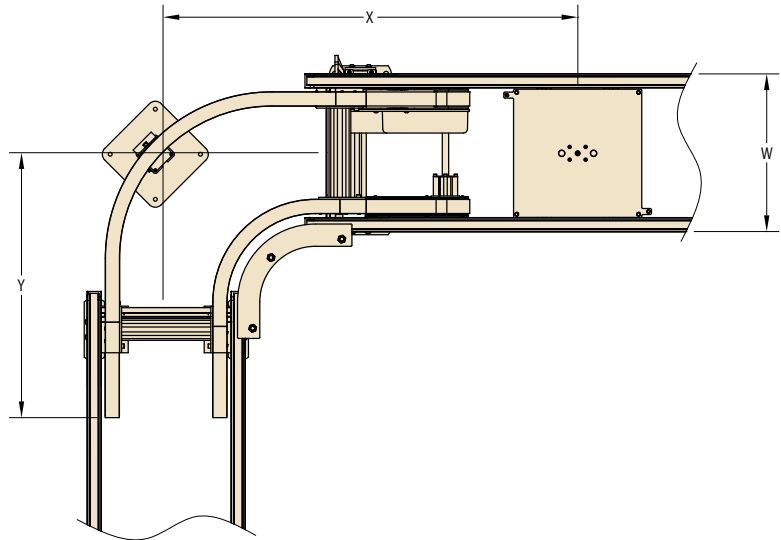

Heavy Load Corner – 180 Degree		
Pallet Width W (mm)	X	Y
320	1150 (45.3)	775 (30.5)
400	1230 (48.4)	855 (33.7)
480	1310 (51.6)	935 (36.8)
640	1470 (57.9)	1095 (43.1)
800	1630 (64.2)	1255 (49.4)

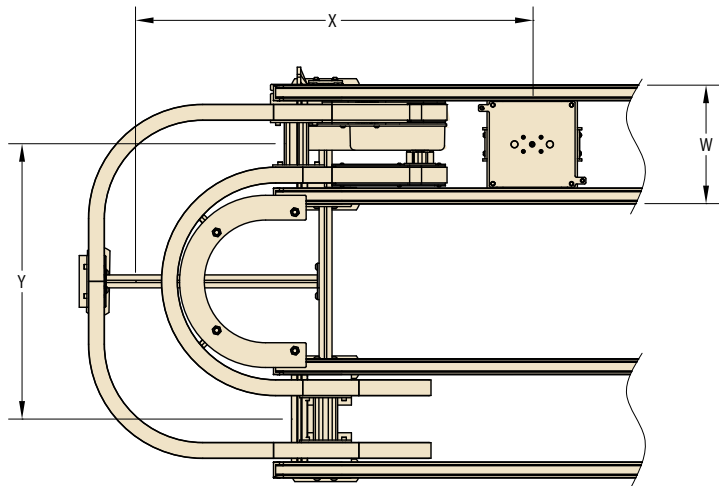

180 Degree Corner		
Pallet Width W (mm)	X	Y
160	495 (19.5)	331 (13)
240	537 (21.1)	390 (15.4)
320	662 (26.1)	470 (18.5)

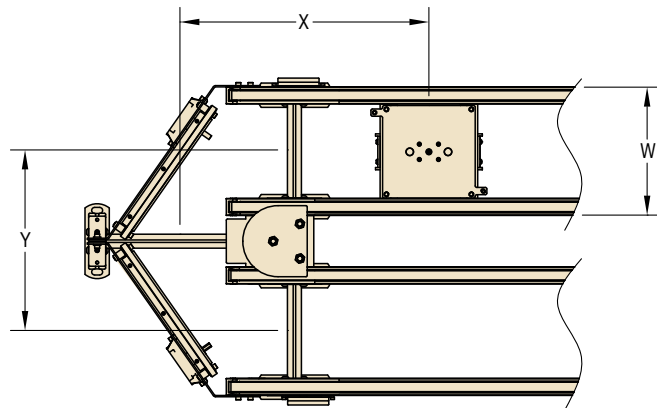

Note: Dimensions = mm (in)

Pallet Plate Details Dimensions

The following details are for standard square pallets only. For other size pallets contact Dorner.

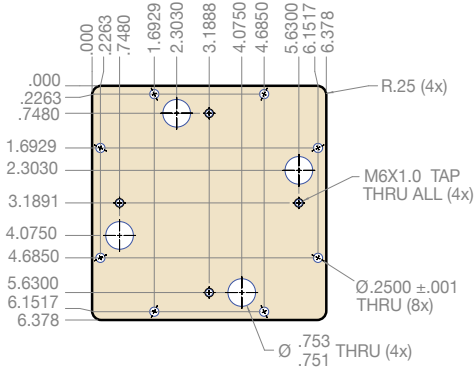

160 x 160

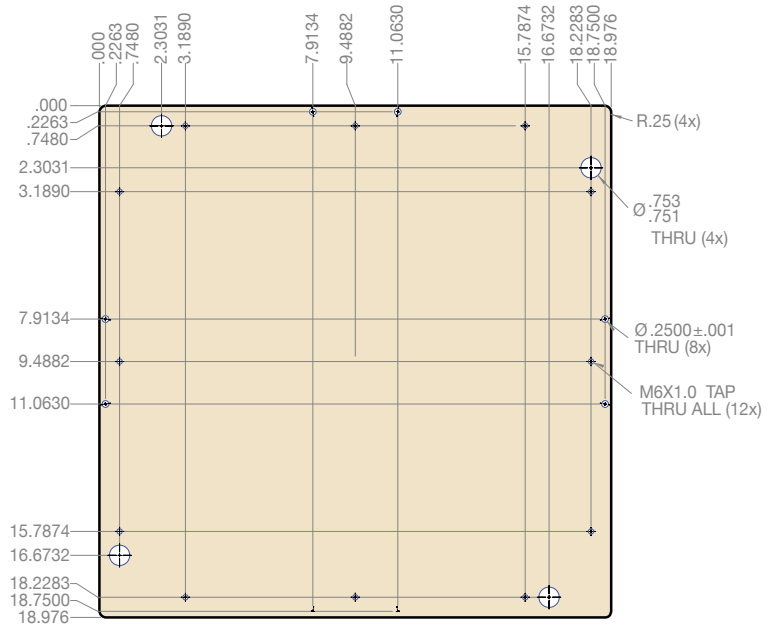

480 x 480

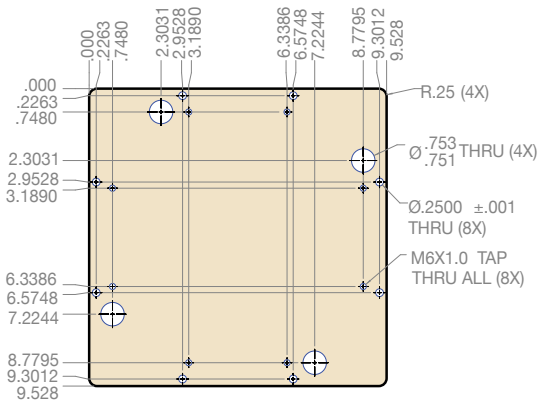

240 x 240

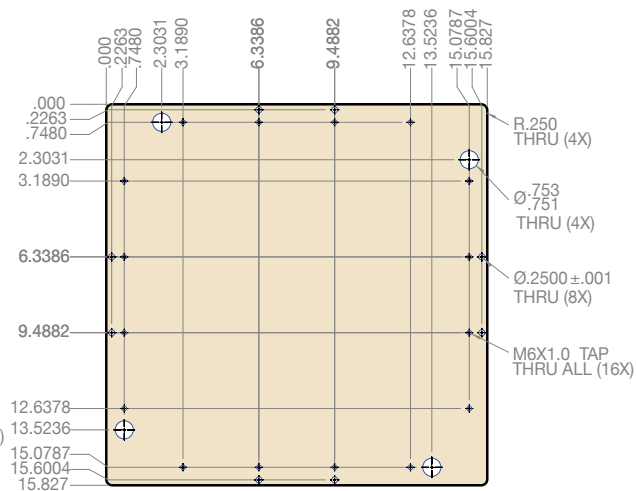

400 x 400

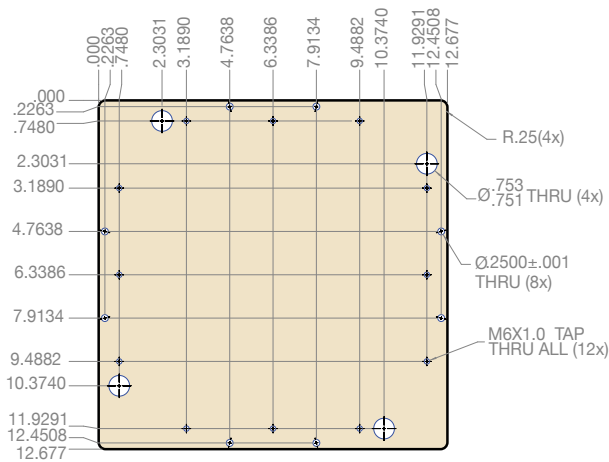

320 x 320

Pallet Plate Details Dimensions

The following details are for standard square pallets only. For other size pallets contact Dorner.

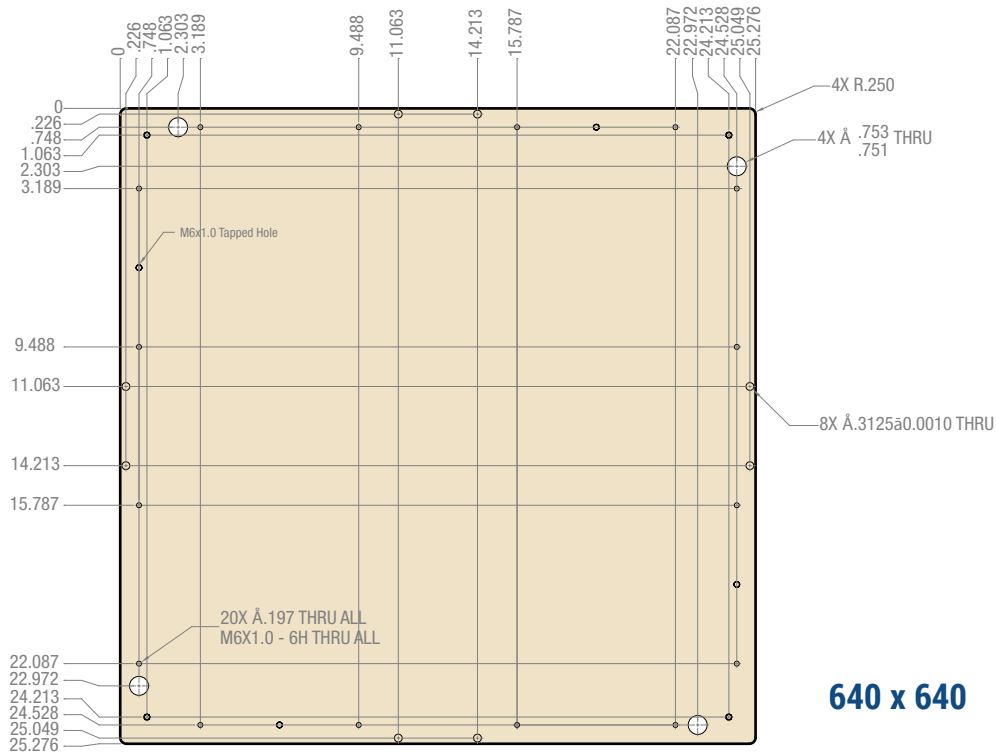

640 x 640

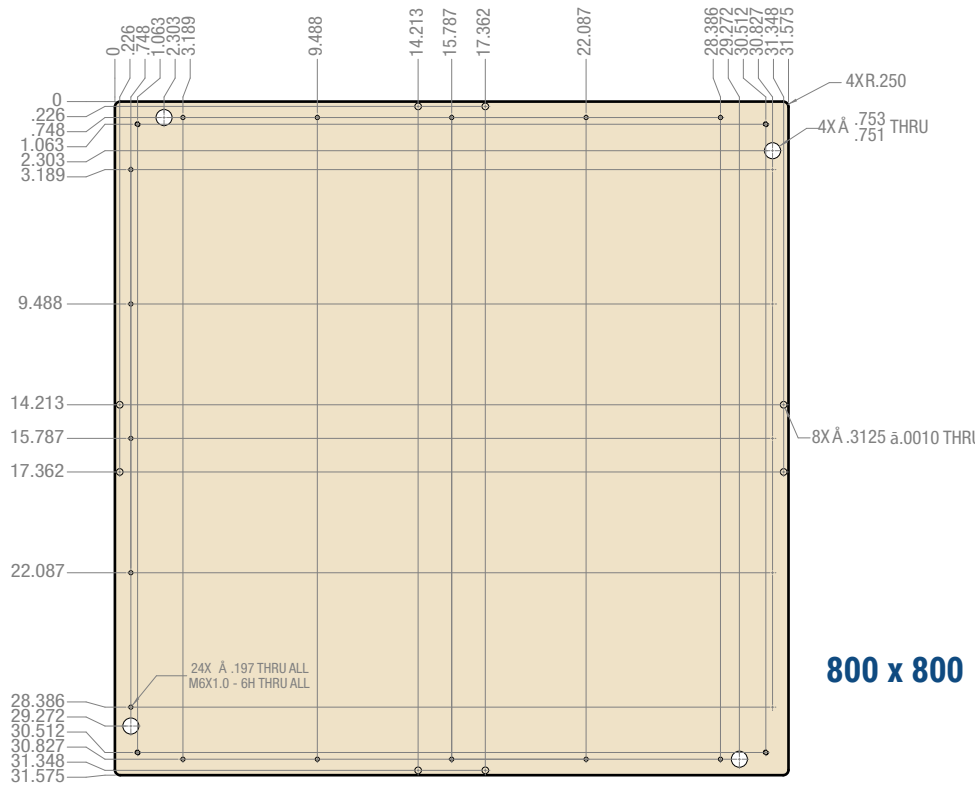

800 x 800

DORNER[®]
By Columbus McKinnon

DualMove Pallet Systems are Best for:

- Medium to Large Size Part Movement
- Product Routing and Control
- Product Inspection
- Assembly Automation in:
 - Automotive
 - Electronics
 - Medical
- Life Science Products
- Health and Beauty Products
- Appliance Products

Sizes & Measurements

- Widths: 160, 240, 320, 400, 480, 640, 800 mm
- Lengths: Up to 7500 mm (24 ft 7 in)

Loads & Speeds

- Conveyor Load Capacity
 - 1250 lbs non-accumulating
 - 625 lbs accumulated
- Pallet capacity of 30 to 100 lbs
- Speeds up to 66 m/min (216 ft/min)

Conveyors

- Dual belt conveyors with common drive module
- 25 mm wide 10 mm pitch timing belt conveyor
- Standard or static conductive belting available
- Aluminum extruded frame with universal T-Slot
- Quick belt change without conveyor removal



Pallets

- 160 mm to 880 mm
- Industry compatible sizes and bushing locations
- Static conductive pallet skirt
- Square and rectangular sizes available
- Pallets available as kits or completed assemblies



Modules

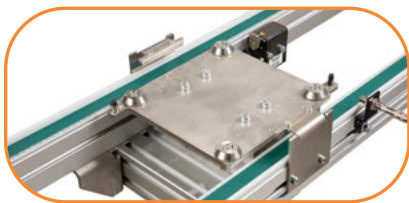

Lift & Locate

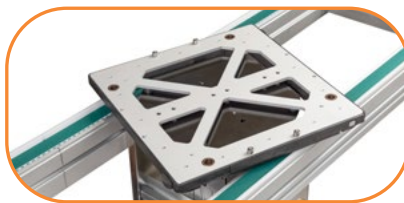

Lift & Rotate

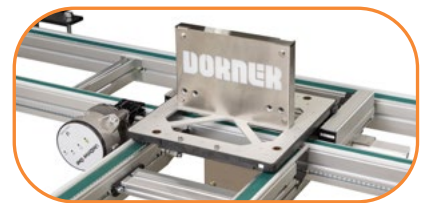

Lift & Transfer

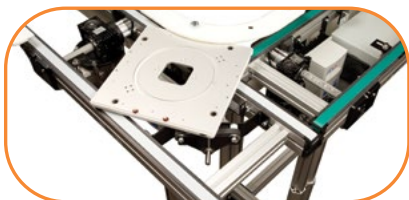

90 Degree Corner



90 Degree Corner & Merge



Cushioned Pallet Stop
(Non-cushioned also available)



Industrial



Flexible Chain



Pallet Systems



Sanitary Stainless Steel



Engineered Solutions Group

Custom engineered solutions for almost any application.



CAD Configurator Tool

Industry leading tool! Configure your own custom conveyor in minutes.

TRANSFORMING CONVEYOR AUTOMATION

Contact Dorner

United States
+1-262-367-7600

Canada
+1-289-208-7306

Mexico
+52.33.30037400

Germany
+49 (0) 2461/93767-0

France
+33 (0)1 84 73 24 27

Malaysia
+604-626-2948



By Columbus McKinnon

DORNERCONVEYORS.COM



CONVEYANCE SOLUTIONS



MAGNETEK

montrate2

© Dorner Mfg. Corp. 2026. All Rights Reserved.

851-995 0626