

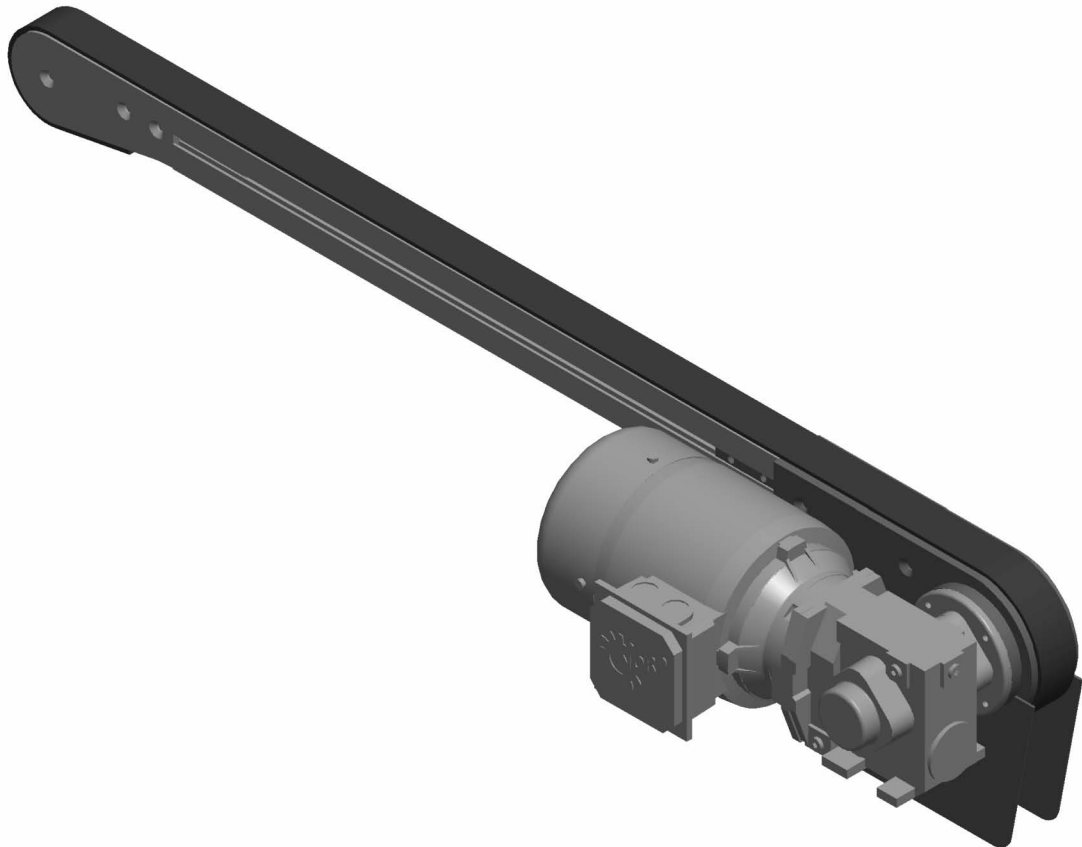

FlexMove FK (45 mm)

Installation, Maintenance & Parts Manual



DORNER MFG. CORP.
P.O. Box 20 • 975 Cottonwood Ave.
Hartland, WI 53029-0020 USA

INSIDE THE USA
TEL: 1-800-397-8664
FAX: 1-800-369-2440

OUTSIDE THE USA
TEL: 262-367-7600
FAX: 262-367-5827

For other service manuals visit our website at:
www.dorner.com/service_manuals.asp

WARNINGS – GENERAL SAFETY.....	3
INSTALLATION GUIDE.....	4 - 19
Introduction.....	4
Support Structure.....	6
Drive Units and Idler Units.....	9
Slide Rail Installation.....	9
Chain Installation.....	13
Guide Rail Installation.....	14
Final Preparations.....	18
Torque Limiter Adjustment.....	19
MAINTENANCE.....	20 - 22
TROUBLESHOOTING.....	23
CHAIN REPLACEMENT.....	24 - 25
GEARMOTOR SELECTION.....	26 - 29
Dorner Provided Gearmotors.....	26 - 27
Selecting SEW or Equivalent Gearmotors.....	28 - 29
SERVICE PARTS.....	30 - 35
RETURN POLICY.....	36

⚠ WARNING

The safety alert symbol, black triangle with white exclamation, is used to alert you to potential personal injury hazards.

⚠ DANGER



Climbing, sitting, walking or riding on conveyor will cause severe injury. **KEEP OFF CONVEYORS.**

⚠ DANGER



DO NOT OPERATE CONVEYORS IN AN EXPLOSIVE ENVIRONMENT.

⚠ WARNING



Exposed moving parts can cause severe injury. **LOCK OUT POWER** before removing guards or performing maintenance.

⚠ WARNING



Gearmotors may be **HOT**. **DO NOT TOUCH** Gearmotors.

⚠ WARNING



Dorner cannot control the physical installation and application of conveyors. Taking protective measures is the responsibility of the user.

When conveyors are used in conjunction with other equipment or as part of a multiple conveyor system, **CHECK FOR POTENTIAL PINCH POINTS** and other mechanical hazards before system start-up.

⚠ WARNING



Loosening stand height or angle adjustment screws may cause conveyor sections to drop down, causing severe injury. **SUPPORT CONVEYOR SECTIONS PRIOR TO LOOSENING STAND HEIGHT OR ANGLE ADJUSTMENT SCREWS.**

INSTALLATION GUIDE

Introduction

The main purpose of this manual is to help self-building end users, with little or no prior experience, to assemble a FlexMove conveyor system. Each chapter includes detailed instructions and pictures showing how to assemble the different parts. Most pictures in the manual include parts from the FS conveyor system, but all instructions are applicable to the FH, FK, FS, FM, FC and FL.

Document Disposition

The document is divided into the following five main parts:

- Installation site preparations
- Tools and fasteners
- Assembly
- Start-up and testing

Initial Assembly Planning

Systematically working planning is required:

- Fully understand and studying the assembly drawing.
- Ensure the necessary tools are required.
- Ensure all the parts and materials well prepared through parts list.
- Enough space for conveyor installation is important.
- Ensure the floor is even and so the foot can be properly attached on the floor.

Safeguarding

All pinch and shear points as well as other exposed moving parts that present a hazard to users is recommended to safe guarded. Cleat conveyor chain is more susceptible of creating pinch and shear points than plain chain.

When two or more pieces of equipment are interfaced, special attention must be given to the interfaced area to ensure proper safeguarding.

For overhead conveyor, guards must be provided if products fall off the conveyor for some reason. The same applies to all incline, decline and vertical conveyors.

Considerations

When correctly applied, the conveyor components are safe to use or maintain. It is however necessary for those responsible to design, installation, operation and maintenance to be aware of certain areas when special caution is required:

End Drive Unit

The chain slack of normal direct drive must be maintained during the system lifetime.

Idler Unit

The opening between links when they turn around idler could be risk. The idler end should not be accessible during conveyor operation.

Catenary Drive Unit

The bridge area where the chain goes down should not be accessible during conveyor operation.

INSTALLATION GUIDE

Assembly Order

During the conveyor assembly works the following items can be used as a checklist.

- Cut all beams into desired length.
- Connect all foots and structural beams.
- Mount conveyor beam support brackets.
- Assembly conveyor beams and mounts them onto the support structure.
- Mount drive and idler unit at the end of the conveyor.
- Mount slide rail onto the conveyor beam.
- Loosen the slip clutch at the drive unit.
- Check any obstruction of the conveyor with short piece chain.
- Assembly and mount necessary chain into the conveyor.
- Mount guide rail and other accessories required onto the conveyor.
- Tighten the slip clutch with suitable friction.
- Read the final preparations at the end of this manual.

Tools General

Tools

To assemble a FlexMove Conveyor, you may need most of the tools listed at the following page. Not all are essential but they will make your work easier and efficient.

Hand Tools

- Wrench
- Slide rail cutter
- Set of metric Allen key
- Counter sunk bit
- Tap measurement
- Roller thread flute less tap and tap wrench.
- Drill fixtures for slide rail
- Riveting Tool
- In addition, the tools listed below can be useful:
- Files
- Socket wrench
- Screw driver
- Pliers
- Knife (cutting off plastic screw head or burr of slide rail)
- Soft head hammer
- Claim tools (for chain installation and dismantle)
- Level

Power Tools

- Hand drill
- Drill bit (of fixing slide rail)

Fastener

Standard Fasteners



M8 = Washer, Counter sunk, Cap screw, Nut, Log nut.

M6 = Washer, Counter sunk, Cap screw, Nut, Log nut.

Square Nut



Square nut can be slotted into T-slot of FlexMove conveyor and support beams. They do not stay in place in vertical positions and have to be inserted from the end of beam. Remember to put in a sufficient number before completing the assembly.

Connecting Strip



Connecting strips are used for joining end to end of beams. Use Allen key and set screws when attaching the connecting strip to the beam.

T-bolt



T-bolts can be entered from the beam side, and when turned 90 degree they will stay in place after tightening with nuts and washers. The indication groove in the T-bolt should be at 90 degree to the conveyor T-slot. T-bolts are used when attaching support brackets, guide rails and drip trays to the conveyor beam. Do not use T-bolts with support beams!

Cutting FlexMove Beam

If you have ordered 3m beams, they will need to be cut into suitable lengths before assembly. Study your drawing to determine the beam lengths required before cutting.

Saw Requirements

The circular cross-cut saw used for aluminum profile cutting must be equipped with carbide tip head saw circulating at high speed for nice and clean cut. The saw should have the ability of cutting the largest profile in one single cutting action.

Working Site

You should use a special area for cutting beams in order to keep the assembly area clean.

Quality of Cut

If burrs are evident, they must be removed prior to assembly. Make sure the cut is straight for proper assembly. All safety precautions issued by the cutting saw manufacturer should be followed at all times.



All safety precautions issued by the cutting saw manufacturer should be followed at all the times.

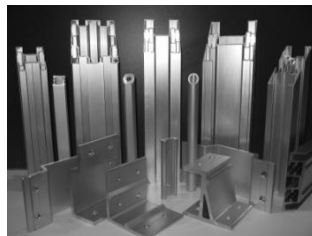

The basic FlexMove conveyor structure consists of five component groups:

- Support structure
- Conveyor beams, straight sections, and bends
- Drive and idler units
- Chains
- Guide rail assembly components
- Other accessories

The first step in the assembly process is to assemble the support structure, which consists of feet, support beams and beam support brackets. Most conveyor support designs are based on vertical support beams, combined, if necessary, with horizontal support beams. There are also a number of different feet and beam support brackets, so check which ones are suitable to use in your application.

Foot Installation

Step 1

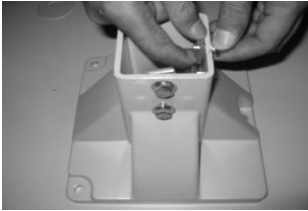

Insert hex head screws and washers into the holes on the side of the foot. Use the screws to fasten foot connecting strips or square nut to the inner side of the foot. Tighten loosely.

Step 2

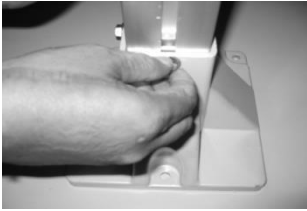

Slide the connecting strips or square nuts into the structural beam T-slots.

Step 3

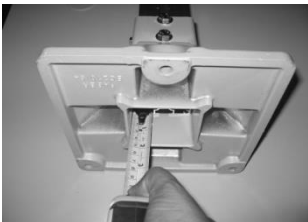

Raise the beam from the bottom of the foot approximately 40-50 mm, to allow for height adjustment later in the assembly.

Step 4



Tighten the screws using a wrench.

Conveyor Installation

Conveyor beams are mounted on to the support structure by means of support brackets. There are three different types of conveyor beam support brackets. They all serve the same purpose but are connected to the structural beams in different ways.

Option 1



Horizontal beam support brackets (60mm or 80mm) are used for horizontal support structure mounted to 64x64mm or 80x80mm support beams. These brackets can also be used as drip tray connectors.

Option 2



Vertical beam support brackets are used with vertical support beams and are made from aluminum.

Option 3



Alpine beam support brackets are used in multi-level alpine conveyor system. This type brackets are used for connecting two parallel conveyor beams to an 80 mm vertical support beam.

Mounting Conveyor Beam Support Bracket

Step 1



Attach screws, nuts and washers to the support bracket before mounting. (Screws and square nuts are support beam fasteners, T-bolts and nuts are conveyor beam fasteners.) Slide the square nuts of one support bracket into the support beam T-slots. Tighten the screws. Make sure that the support bracket is aligned with the beam cross-section as shown in the drawing.

Step 2



Insert the square nuts of the second support bracket into the support beam T-slots. Slide the bracket down so that it does not protrude above the cross-section of the beam.

Step 3



Use a soft hammer or mallet to mount an end cap on to the support beam.

Step 4



Mount the first support bracket to the conveyor beam. Pull the second bracket up and insert the T-bolts into the conveyor beam T-slot. Tighten the nuts.

Conveyor Beam Installation

The next step is to connect conveyor beams – straight sections and bends – to each other. Connect all conveyor beams according to the instructions below.

Step 1

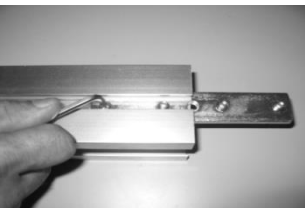

Connect two conveyor beam ends by inserting connecting strips into the beam T-slots. Use two connecting strips per beam joint.

Step 2

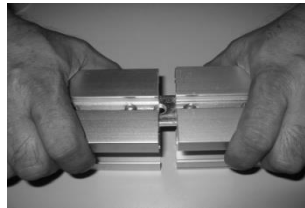

Make sure that the set screws do not prevent the connection strips from sliding into place.

Step 3



Tighten the set screws using an Allen key.

NOTE: Assemble the entire conveyor beam structure in the same way. If the conveyor beam is too long to mount onto the support structure in one continuous length, assemble shorter lengths and connect them to each other once fastened to the support beams.

INSTALLATION GUIDE

Drive Unit and Idler End Unit Installation

Step 1 – Drive Unit

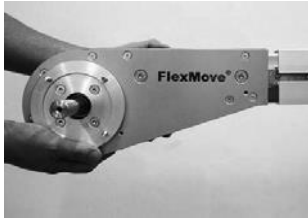

Mount the end drive unit on to the end of the conveyor. Release the four set screws that are inserted into the drive unit connecting strips. Insert the connecting strips into the T-slot of the beam you want attached to the end drive unit. Make sure that the set screws do not prevent the connecting strips from sliding into place.

Step 2 – Drive Unit



Tighten the set screws using an Allen key.

Step 1 – Idler End



Insert the idler unit connecting strips into the T-slots of the beam end and tighten it.

Step 2 – Idler End



Tighten the set screws using an Allen key.



The opening between the links when they turn around the idler could be a risk. Idler ends should not be accessible during conveyor operation.

Attaching Slide Rail in Straight Beam

Step 1



Start the slide rail assembly at an idler end unit. Separate the top and bottom flange of the slide rail at the end of rail and press into place.

Step 2

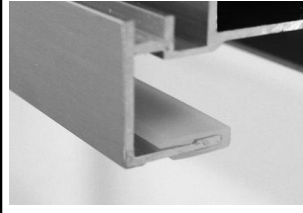

Make sure the slide rail is proper mounted and snaps onto the beam. Please identify the longer flange of the slide rail must always face inner of the beam.

Step 3

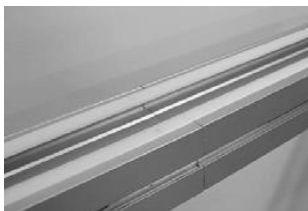

When using articulated beam, the slide rail must be mounted across the entire beam section. Remember to mount slide rails both top and underneath side of the beam. (unless top running chain only)

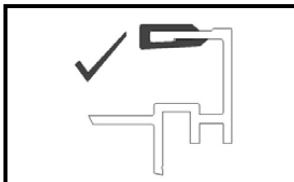

Correct Installation

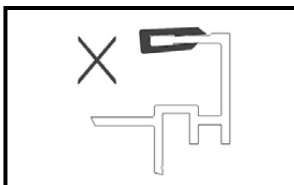

Wrong Installation

INSTALLATION GUIDE

Slide Rail End Installation at Conveyor Beam

Step 1

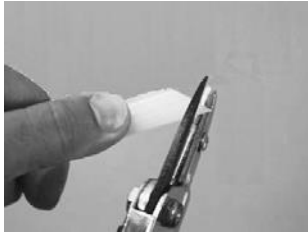

Cut both slide rail ends in a 45° angle. The beginning of a new slide rail (in the direction of travel) must cut back a small angle.

Step 2

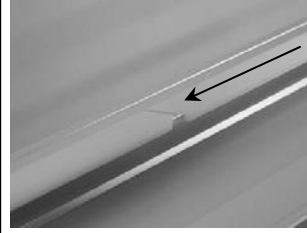

Allow a space of approximately 2mm to 5mm between two slide rail ends. The travel direction is indicated by arrow.

Step 3

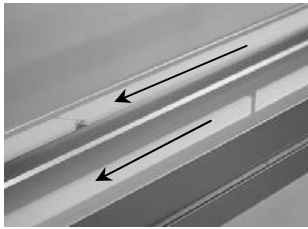

Do not place two slide rail joints opposite each other. Make sure there is a distance of at least 100 mm between them to make the chain run smoother. This does not apply to slide rail that begins by an idler unit or after a drive unit, where joints are always parallel.

Try to let the slide rail run in as continuous lengths as possible by reducing number of breaks, except in circumstances stated below:

- It is recommended to use short slide rails (2–3m) where chemicals may have an effect on the slide rail composition.
- It is important to cut the slide rail and allow for elongation in high load areas. Cutting is required in wheel bends (see following page), at idler units and where the conveyor will be heavily loaded, especially at drive unit. This prevents the slide rail from stretching out and entering into the drive unit, which may block the chain movement.
- Never join slide rail in horizontal or vertical bends, since forces are higher on the slide rail in these sections. Instead, place the joint before the bend.
- Avoid joining slide rails on top of conveyor beam joints.

Slide Rail Installation at Wheel Bend

Step 1 – In feed Wheel Bend (New Type A)

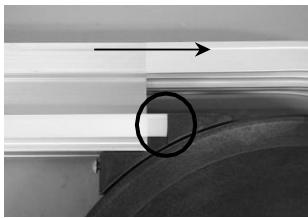

Cut the slide rail end in flat. Make sure there is no gap created at the plastic molding part. The step is applied onto out feed as well.

Step 2 – Out feed Wheel Bend (New Type A)

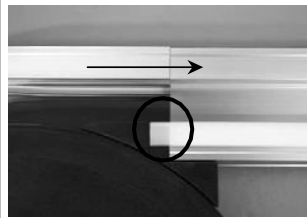

Follow Step 1.

Step 3



In the outer bend, make sure that the slide rail is properly connected to the conveyor beam profile.

Horizontal Plain Bends and Vertical Bend

In plain bends with small radius and vertical bend, the slide rail for the inner bend should be cut so that it is only 10mm wide in the bend. This is to prevent an uneven slide rail surface. Stretch the rail while mounting.

Drilling Slide Rail

Step 1



Drill two holes near the beginning of each slide rail section. Use the drill fixture to ensure clean-cut holes and the correct location of the holes. For drill bit radius, see table. The holes must be at the leading edge of the joint piece, in the direction of travel, to hold the slide rail in place when the conveyor is in use. Use a well sharpened 4.3mm drill-bit. The arrow indicates running direction.

Step 2



Use a bigger drill bit to deburr and countersink the holes. Also make sure that there are no metal filings left underneath the slide rail.

Fixing Slide Rail

The beginning of each slide rail section must be fixed to the beam, since the chain will cause the slide rail to be pushed forward. Slide rail which moves into a wheel bend or a drive unit can block the chain completely. Riveting method is more secure if the conveyor will run with high operational speed or be heavily loaded.

Step 1 – Nylon Screw

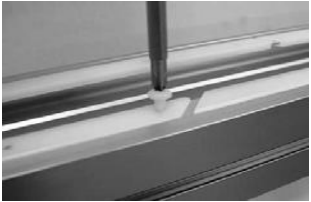

Screw or press the nylon screws into the holes using a screwdriver or a pair of pliers.

Step 2 – Nylon Screw



Cut off the head of nylon screws by using soft hammer and knife. Remember, cut must be made away from the joint, in the direction of chain travel.

Step 3 – Nylon Screw



After cut, make sure the slide rail surface is smooth and the nylon screws do not protrude over the slide rail surface. File the protrude edge if uneven surface is found.

Step 1 – Aluminum Rivet



Insert the aluminum rivets into the holes.

Step 2 – Aluminum Rivet



Clamp the aluminum rivet by using crimping pliers.

Checking Slide Rail and Rivet Condition After Fixed

Slide Rail Checking 1

correct



wrong



Ensure slide rail do not protrude due to the over pressed during rivet process.

Slide Rail Checking 2

correct



wrong



Check that the rivets do not protrude over the surface of the slide rail. Check both top and underneath surface of slide rail for protruding metal.

Joining Chain End

Assemble the chain by inserting the steel pin that comes with each chain link, into the opposite end of another link. Do this by using the FlexMove pin insertion tool.

Step 1

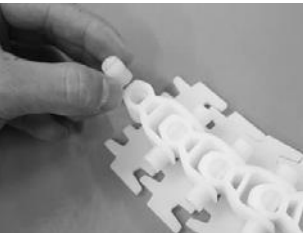

Insert the plastic pivot with the slot facing outward.

Step 2



Insert the steel pin halfway, using a pair of pliers. Always use new steel pins and plastic pivots when joining chain ends.

Step 3



Line the FlexMove chain tool up with the pin. Slowly depress the trigger until the pin seats.

Step 4

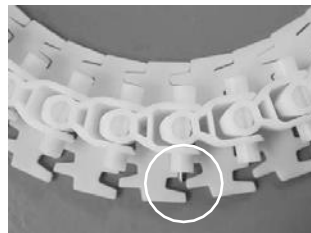

Check that the chain is flexible in the joint and that the pin does not stick out or go through the other side.

wrong

Chain Installation at Drive Unit

Make sure that the slip clutch is released allowing the drive shaft to turn freely.

Step 1



Insert the chain into the underside of the drive unit. Make sure the chain will be moving in the correct direction, as indicated by the arrow located at the side of all chain links.

Step 2

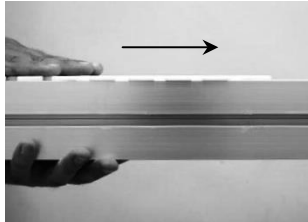

Feed the chain along the conveyor by pulling it through the idler unit and back to the drive unit.

Step 3

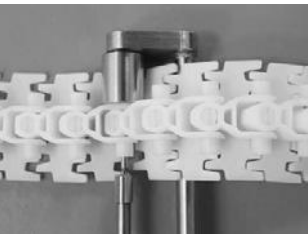

Join 5 meter lengths of chain when necessary.

Step 4



Tension the chain and remove links if necessary, so that the chain will exhibit some slack at the drive unit. Put in the stainless steel pin at the hole provided at drive unit and join the chain.

Chain Assembly at Chain Disconnecting Module F..CC

Step 1



Loosen the screws on the beam section flanges.

Step 2

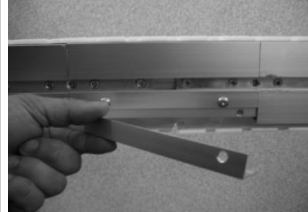

Remove the flange so that the chain becomes accessible.

Step 3



Clamp the chain to the beam profile. Use the FlexMove chain tool to remove a steel pin from the chain, so that two links are separated.

Step 4

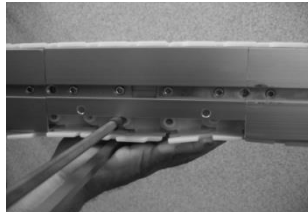

Remove excess links and use the chain tool to put the chain back together again.

INSTALLATION GUIDE

Length Adjustment of the Conveyor Chain

End drive units, catenary drive units

1. of the conveyor chain is carried out at the drive end of the conveyor.
2. Adjustment The transmission guard cover must be removed from the drive unit and the slip clutch disengaged or transmission chain removed. The conveyor chain should now be free to travel within the conveyor beam profile.
3. Catenary protection plates should also be removed to allow easy access for the conveyor chain pin insertion tool.
4. The conveyor chain should be tensioned within the conveyor system by pulling down the conveyor chain at the chain catenary in the underside of the drive unit. Clamp across the conveyor chain to trap the chain on to the beam profile. The clamp should be placed over the edges of the drive unit to reduce the risk of damage to the aluminum profile.
5. Remove all slack links from the conveyor chain using the pin insertion tool.
6. Rejoin the conveyor chain using a new steel pin and plastic pivot.
7. Remove the chain clamp and replace the catenary protection plate and transmission chain. The slip clutch should also be reset.
8. Replace the transmission guard cover. The conveyor is now ready for operation.

Intermediate drive units, horizontal bend drive units

1. Conveyors which have no conveyor chain slack should be assembled with a special section of conveyor beam (F..CC), which allows for the chain to be easily inserted and adjusted for tension. (See previous page.)
2. Remove the lower part of this conveyor beam section by releasing the four screws.
3. Lift the chain from this section of the beam and clamp the conveyor chain as described above. Adjust the chain tension as for end and catenary drive units.

In a wheel bend drive, the outer aluminum profile can be removed by loosening the set screws in the beam connecting strips. The slide rail must be fitted to allow the removal of this section.

1. After removal of the outer aluminum profile, the conveyor chain can be pulled out of the wheel bend disc. Lift the chain upwards.
2. Remove chain links using the pin insertion tool.
3. New steel pins and plastic pivots must be used when rejoining chain ends.
4. The tensioned chain can now be pulled back into position on the bend guide disc, and the outer profile put into place.

Guide Rail System Installation

Guide rails are used to guide products being conveyed, but also to prevent them from falling off the conveyor. Guide rails are supported by guide rail brackets attached to the sides of the conveyor beam. Follow the mounting instructions for the type of bracket used in your application. Brackets should be placed approximately 500 to 1000 mm apart depending on type of product and if accumulation occurs or not. If brackets are spaced at greater distances than 1000 mm, there is a possibility that guide rails will become deformed due to excessive force. The pictures below show one possible way to assemble guide rail brackets. The examples shown on the following page are assembled in a similar way.

Step 1 – Adjustable Guide Rail Bracket



Fasten an adjustable guide rail bracket support to the conveyor beam using T-bolt.

Step 2 – Adjustable Guide Rail Bracket



Attach the guide rail to the clamp. Tighten the screw. Remember; do not over tighten the screw. After this, tighten all the screw of the bracket to fix its position.

Assembly with Different Guide Rail Support

Option 1



Option 2



Note: Tighten all the screws when the position is justified.

FGRB-48x12V Heavy Duty Guide Rail Bracket Assembly

Step 1



Prepare the heavy-duty guide rail bracket with T-bolt.

Step 2



Attach the bracket onto conveyor beam and tighten with long wrench.

Assembly with Different Guide Rail Support

Option 1



Option 2



Option 3



Note: Tighten all the screws when the position is justified.

FGRB-48x12V Spacer Assembly

Step 1

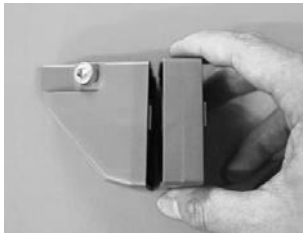

Attach the spacer onto FGRB-48x12V and prepare the bracket with T-bolt.

Step 2



Attach the bracket onto conveyor beam and tighten with long wrench.

FGRB-40x18, FGRB-40x20 and FGRB-40x15x20 Heavy Duty Guide Rail Bracket Assembly

Step 1 - Method 1



Open the upper and lower caps and prepare the FGRB-40 heavy duty guide rail bracket with T-bolt.

Step 2 - Method 1



Attach the bracket onto conveyor beam and tighten with long wrench.

Assembly with Different Guide Rail Support

Option 1



Option 2



Note: Tighten all the screws when the position is justified. Remember to assemble the upper and lower caps onto the bracket

Step 1 – Method 2



Open the upper and lower caps and prepare the FGRB-40 heavy duty guide rail bracket with T-bolt.

Step 2 – Method 2



Attach the bracket onto conveyor beam and tighten with long wrench. After this, close both caps of the bracket.

Fixed Guide Rail Bracket Installation

Step 1 – Fixed Guide Rail Bracket



Fasten a fixed guide rail bracket support to the conveyor beam using T-bolt.

Step 2 – Fixed Guide Rail Bracket



Attach the guide rail to the bracket. Clamp the spring pin into the slot between bracket and guide rail to fixed the position.

Guide Rail Connecting Installation

Step 1 – Rail Connecting



First, fully slot the guide rail sleeve into either one of the guide rail profile that you are going to join.

Step 2 – Rail Connecting



Now, align these 2 profiles closely in parallel.

Step 3 – Rail Connecting

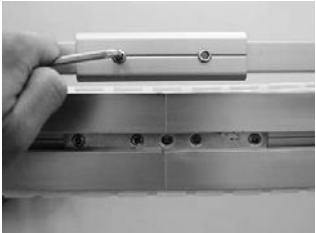

Finally, move the guide rail sleeve into second profile. Tighten when the location is justified.

Step 1 – Connecting Plug

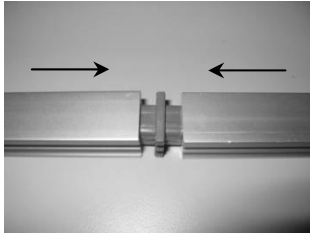

Connecting plugs are pressed into two guide rail ends with soft hammer.

Guide Rail Cover Installation

Step 1



To prevent products from being scratched, a plastic guide rail cover can be snapped on to the inside of the guide rail.

Step 2



Make sure that all cover joints are smooth, so that products do not get caught or damaged. Do not join covers on top of guide rail joints.

Final Preparations

Plug Beam Ends

Ensure that end caps have been fitted to all aluminium profile ends. The beam profiles should be deburred before fixing end caps. It may be necessary to fix the cap into position using a soft-faced hammer.

Anchor Feet to the Floor

After the assembly of all components it may be necessary to anchor the conveyor support feet to the floor. Use a type of fastener that is right for the kind of floor where the conveyor is installed.

Instability of the conveyor during operation may result in a dangerous operating environment or damage the conveyor components.

Other Preparations

- Adjust the height of the structural beam if necessary.
- Make sure that the installation is stable and that all screws have been properly tightened.
- Use a plummet and/or water-level to make sure that the construction is not askew.
- Make sure that all electrical equipment and power supply are properly connected.
- Make sure that the conveyor is running in the correct direction before starting the conveyor! Never run the conveyor with tightened slip clutch until you have ensured that the running direction is correct.
- Tighten the slip clutch to a suitable friction.
- Make sure that the transmission cover is attached to the drive unit.
- In pallet installations, make sure that all pneumatic equipment is properly connected.

Remember that conveyor chains should always be pulled, not pushed, by the drive unit.

Start-up and Testing

Safety Considerations

To eliminate the risk of accidents, it is important to be aware of certain areas of the conveyor where special caution is required, during installation, operation and maintenance. Some areas present a higher danger to personal safety, and because of this various kinds of safety devices need to be installed.

- All pinch and shear points as well as other exposed moving parts that present a hazard to employees at their workstations or their passageways must be safeguarded.
- Cleated conveyor chains are more susceptible of creating pinch and shear points than plain chain.
- When two or more pieces of equipment are interfaced, special attention must be given to the interfaced area to ensure proper safeguarding.
- For overhead equipment, guards must be provided if products may fall off the equipment for some reason. The same applies to all incline, decline and vertical conveyors.

Safeguarding can be achieved by:

Location – locate the hazardous area out of reach of the personnel involved.

Guards – mechanical barriers preventing entry into the hazardous area or protecting against falling goods.

Control devices – machine controls preventing or interrupting hazardous conditions.

Warnings – instructions, warning labels, or sound or light signals, alerting on hazardous conditions.

Warnings shall be used when other means of safeguarding will impair the function of the installation.



It must be difficult to bypass or inactivate safeguards during operation! Safety devices should be designed to minimize discomfort or difficulties for operators.

Torque Limiter Adjustment

Introduction

The slip clutch on the drive unit is a safety device which allows the chain to stop if the load becomes excessive. It has two purposes:

- Prevent damage to conveyor
- Prevent damage to the products on the conveyor12345678

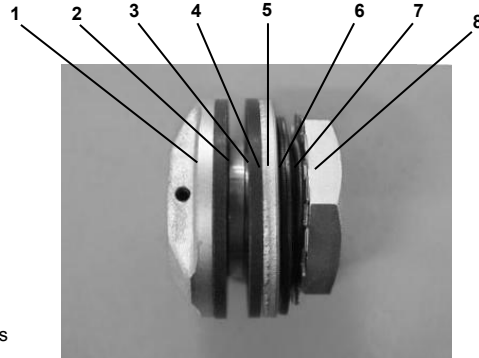

Name of parts

- | | |
|----------------|--------------------|
| 1. Hub | 2. Friction Facing |
| 3. Bushing | 4. Pressure Plate |
| 5. Disk Spring | 6. Lock Washer |
| 7. Pilot Plate | 8. Adjustable Bolt |

Torque Limiter Manual

1. Assembly
2. Machining accuracy on center member
3. Run-in
4. Torque setting
5. Tightening method for adjustable nut and bolts
6. Replacing the friction facing
7. Maintenance and precaution

Assembly of Torque Limiter

Wipe off oil, rust and dirt from each part before assembling your Torque Limiter. Then, assemble as follows. Note that all units are assembled with a single disk spring. An additional disk spring is packed separately for use as necessary.

Machining Accuracy on Center Member

Machine the center member friction surface and bore at 3S~6S

Run-In

Usually, run-in operations for the Torque Limiter are not necessary. Of a stable slip torque is required, however, make sure to completely hand tighten the adjustable nut or bolts. Then tighten 60 degree more and run or rotate the Torque Limiter approximately 500 revolutions. If the rotation speed is high, run-in several times to reach 500 revolutions.

Torque Setting

After installing the Torque Limiter to your machine, tighten the adjustable nut or bolts but not too tight. Then, test several times by gradually tightening the bolts to find the appropriate tightening value. Correlation between the adjustable nut or bolts tightening value and slip torque are illustrated below. Slip torques vary depending on the friction surface. Graphs only show rough figures, so test with a slightly weaker torque first, then gradually tighten to find the appropriate torque suitable for your machine. This is the most practical way.

Tightening Method for Adjustable Nut or Bolts

The adjustable nut for Torque Limiter is a hexagon head nut. Tighten it with a spanner wrench to the rated angle then bend the lock washer to prevent the adjustable nut from loosening.

The adjustable nut has 3 pieces. Of adjustable bolts. Place the pilot plate and disk spring in contact with each other, and tighten the adjustable nut manually until there is no backlash between their faces. Then retighten the adjustable bolts to the appropriate angle.

Replace the Friction Facing

Change the friction facing when they reach roughly half the thickness of dimension described above. 1.25mm for L250. Before replacing the friction facing, each part must be completely free of oil, rust and dirt. Also, reassemble the Torque Limiter according to the structure drawing.

Maintenance and Precautions after the Replacement Procedure

Periodically inspect the torque setting, for the initial torque setting may be affected by changes in friction, ambient temperature, humidity and other conditions. Replace the friction facing and bushing if they wear. Their replacement parts are in stock.

Keep the Torque Limiter free from water and oil. This will maintain the effectiveness of torque and prevent the equipment or load from falling and causing serious accidents.

Safety



WARNING!

- Before carrying out maintenance, make sure there is no load or turning force applied to the machine.
- Inspect operation periodically for overloads.
- Comply with Ordinance on Labor Safety and Hygiene 2-1-1 general standards.
- Comply with this manual when conducting unit installation, removal, maintenance and inspection.



CAUTION!

- Read this manual thoroughly before servicing the unit, and handle the unit correctly.
- Design the equipment so that it can tolerate load and rotational force when overloaded.
- Mechanical parts may wear depending on the rotation speed and slipping time. Check the operation periodically, and for any mechanical failure, contact us.
- This manual is an essential part of the unit, and it should remain with the unit at all times including when redistributed.

MAINTENANCE

Start-up and Maintenance Schedule

The chains are made of acetyl resin which has an excellent combination of strength, wear, chemical resistance, impact strength and temperature range. Chain failures like breakage and high wear might occur if the actual pull is higher than the permissible chain limit. There is also high risk of slip-stick effect if the conveyor is running at high chain tension.

The chain running on the right direction is very important. The chain top and bottom is like an arrow and the conveyor must travel toward the arrow. The chain should run without pre-tension. Pre-tension might result in uncontrolled chain pull and lead to chain failure. For this reason, it is important that there is a visible chain slack at the bottom of the drive unit when the conveyor is running.

The chain has good impact strength a broken link is a sign that something is wrong along the conveyor. Frequent failures are broken cleat link caused jamming at the loading or unloading of the conveyor.

Slide Rail Lubrication

Lubrication of the surface between the slide rail and chain will result in low coefficient of friction, less noise and longer running life. It is especially applicable for plain bends. But, it is not compulsory as the chain and slide rail materials are self-lubricant.

Wear

The degree of wear on a conveyor depends on a number of factors, such as:

- Running time
- Load, contact pressure
- Speed
- Product accumulation
- Sharp or rough products
- Chemicals
- Foreign particles, e.g. chips, grinding particles, broken glass, sand, sugar
- Temperature
- Plain bends

Try to minimize the running time for the conveyor by stopping it when there is no transport. Multiple horizontal and vertical plain bends in a conveyor will often result in increased wear. One reason is that the friction losses are large in plain bends. Also, the contact surface between chain and slide rail is small and the chain pull is acting towards the slide rail in the bends.

Chain Elongation

Acetyl resin is an elastic material. In addition to the elastic elongation, the chain will exhibit elongation because of material creeping. The magnitude of chain elongation will depend on the chain tension. The chain elongation will show up at the bottom of the drive unit. Too much of the chain slack may cause high wear at the drive unit entry point. Chain slack of up to 150 mm is acceptable during normal running but any slack longer than that is not advisable. The chain slack might also hit on any part below it and this depends on the drive unit configuration. For this case, the chain slack should be shortened much earlier. In normal case, chain should be shortened after run-in time of 40 hours. The next inspection should be made only after 200 hours of running and then every 1600 hours. More frequent inspections are recommended if the conveyor is long and on high load.

The chain should therefore be pre-tensioned while the conveyor is stationary, but must never be so tight that there is no slack during the operation. There should be no appreciable slack on the chain when the conveyor is stationary. If there is too much slack, there will be excessive wear on the chain guides and the chain. This could be a risk for injury. If the slack on the conveyor chain is unacceptably high, it must be shortened by splitting the chain and removing the necessary number of links.

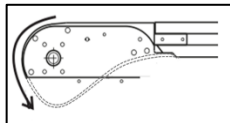

The conveyor chain must show some slack during operation

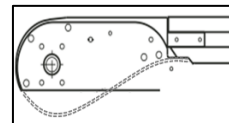

The conveyor chain does not need to show any slack when the conveyor chain is stationary.

Inspection

Visual check the slide rail in horizontal and vertical bends after every 200 hours of operation. The chain can stay in place during the inspection. Replace any worn out slide rail. Remove the chain from the conveyor and inspect the slide rail carefully once every 1500 hours of operation. Check for any worn out slide rail and any other unusual condition and make necessary replacement. You must also clean up the dirt accumulation in the conveyor beam especially before all plain bend, wheel bend, drive unit and idler end.

Drive Unit

Each drive unit can be equipped with different gear motor brands. Please follow the maintenance recommendations from the manufacturers.

Proposal Schedule

Maintenance is recommended to carry out every 3rd, 6th and 12th month and subsequently every 6th month considering the running condition. Following are the recommended actions to be carried out:

First 3rd month:

- Shortened the chain.
- Visual inspection on the running wear of the slide rail, sprocket, wheel and chain guides.
- Checking on any high wear part on the conveyor and rectify it when necessary.
- Clean up any foreign accumulation that might block the smooth flow of the conveyor.
- Checking on the gearbox oil level and top up when necessary.
- Checking all parts joint for support structure, slide guide and conveyor for loosen joint, rectify when necessary.

First 6th month:

- Shortened the chain.
- Visual inspection on the running wear of the slide rail, sprocket, wheel and chain guides.
- Checking on any high wear part on the conveyor and rectify it when necessary.
- Clean up any foreign accumulation that might block the smooth flow of the conveyor.
- Checking on the gearbox oil level and top up when necessary.
- Checking all parts joint for support structure, side guide and conveyor for loosen joint, rectify when necessary.

First 12th month:

- Shortened the chain.
- Visual inspection on the running wear of the slide rail, sprocket, wheel and chain guides.
- Checking on any high wear part on the conveyor and rectify it when necessary.
- Clean up any foreign accumulation that might block the smooth flow of the conveyor.
- Checking on the gearbox oil level and top up when necessary.
- Checking all parts joint for support structure, side guide and conveyor for loosen joint, rectify when necessary.

Checking Slide rail with the conveyor chain in place

The slide rail needs to be checked after every 200 hours' operation. Carry on the checking on a stationary condition with the chain in place.

- Check the screwing points on the slide rail
- Check the joints section on the slide rail.

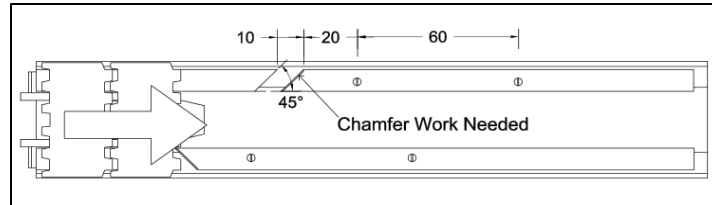

Correct Configuration of joints

- Check that the gap between the slide rails and the joints are fit correctly.
- Check that the nylon screw is fit and do not protrude over the surface of the slide rail.
- Check that the joint sections are not deformed.

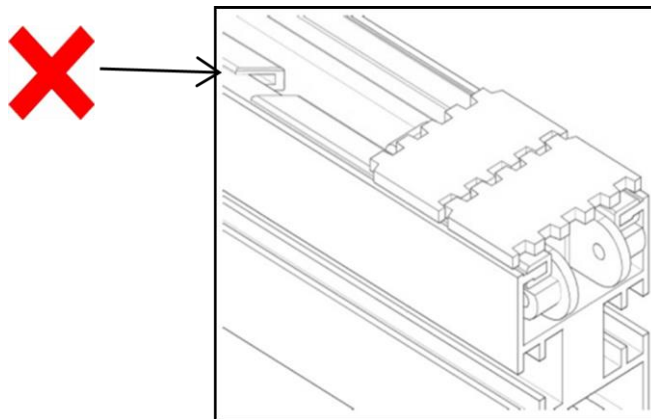

MAINTENANCE

Deformed Joints

Checking the slide rail, conveyor chain has been removed

The slide rail needs to be checked once in years or after 1500 hours' operation. The chain should be removed from the conveyor beam for checking the slide rail carefully on the condition of wear and the screwing.

Horizontal bends need to be checked carefully after every 400 hours' operation, since these are the place where are subjected to more friction loads.

- Carry out the same checks as the "checking slide rails with the conveyor chains in place".
- Check the wear and tear condition for the slide rail.

Remarks

Check the inner slide rail in horizontal bends obviously, since the frictions here are particularly high. The conveyor chain interface more on the inner slide rail compared to the outer slide rail.

- Check the slide rail for the scratches and notches.
- Replace the slide rail and the screwing parts if necessary.
- Clean the conveyor chain and check the condition of the chains as well.
- Tidy the conveyor beam.

Protective and safety device

Safety devices should be checked at regular intervals.

- Check the motor cover for the chain transmission.
- This motor cover must always be in place when the conveyor is operating.
- Check the drive cover always be in place when the chain is moving on the drive unit.
- Drive unit always have a chain cover to protect the safety of the users. The chain slack always could be seen during the conveyor is running at the drive unit. Check that the chain cover plates are in place, and that the chain does not slacken enough to hang below the plates.
- Check that the chain cover for the conveyor chain on the intermediate drive units and the catenary drive units.



Motor cover for the bicycle chain transmission



Drive Cover to cover the chain slag for suspended drive unit



Troubleshooting

Symptom	Cause	Corrective action
Jerky running	<ul style="list-style-type: none"> - Damage or badly fitted slide rail. - Wrongly adjusted slip clutch. - Worn transmission parts. - Conveyor chain is too tight or loose. - Dirty conveyor 	<ul style="list-style-type: none"> - Inspect and replace as necessary. - Check and adjust slip clutch. - Check/replace transmission chain, chain drive sprocket. - Tension conveyor chain correctly. - Clean conveyor chain/slide rail.
Drive unit is running; conveyor chain is not running	<ul style="list-style-type: none"> - Wrongly adjusted slip clutch. - Friction discs in slip clutch are worn or contaminated. - Damage/badly fitted slide rail. - Transmission products are not fitted. 	<ul style="list-style-type: none"> - Check adjustment of slip clutch. - Check and replace if necessary. - Check the free running of the conveyor chain. - Check and fit.
Motor overheating on drive unit	<ul style="list-style-type: none"> - Overload conveyor. - Gearbox leaking oil. - Dirty conveyor. 	<ul style="list-style-type: none"> - Remove products from conveyor and test run. - Check actual conveyor load against recommended loading. If possible, break to more drives. - Check output shaft seal and area around motor/gearbox interface. - Clean the conveyor chain with warm water 50 degree.
Noise	<ul style="list-style-type: none"> - Worn or damaged bearings in drive unit. - Damage/badly fitted slide rail. - Excessive conveyor speed. - Incorrect conveyor chain tension. 	<ul style="list-style-type: none"> - Check/replace drive unit. - Check the free running of the conveyor chain, especially in slide rail joints. - Check actual load against recommended loading. - Lengthen/shorten conveyor chain
Abnormal wear of plastic parts	<ul style="list-style-type: none"> - Overloaded conveyor. - Ambient temperature too high. - Foreign object dropped on the conveyor chain. 	<ul style="list-style-type: none"> - Remove products from conveyor and test run. - Check the free running of the conveyor chain. - Check actual conveyor load against recommended loading. If possible, break the conveyor into more drives. - Check against recommended temperature for conveyor. - Replace the broken section of chain.
Clutch Ratcheting or slipping	<ul style="list-style-type: none"> - Excessive or accumulated load. - Improper ratchet clutch tensioning. - Damaged or missing chain assembly parts. - Accumulation of conveyed material or foreign objects inside of casing. 	<ul style="list-style-type: none"> - Avoid load buildup by running conveyor continuously. - Do not manually surge load conveyor. - Refer to ratchet clutch adjustment in Maintenance. - Review belt and repair or replace as required. - Reverse conveyor placing ball of newspaper or a rag on belt to act as wipeout for accumulated material.

Replacement of worn part –conveyor chain

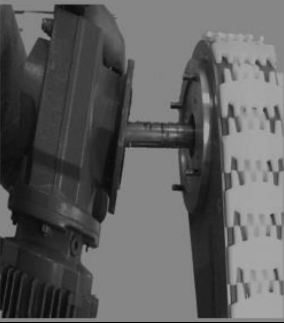
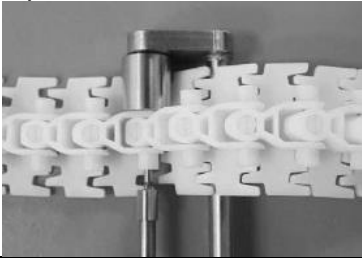

Removal of Conveyor Chain

Remove the worn part of the conveyor chain by using the FlexMove pin insertion/removal tool. Make sure that the slip clutch is released allowing the drive shaft to turn freely.

<p>Step 1</p> 	<p>Ensure that the power supply for the drive motor is disconnected.</p>
<p>Step 2</p> 	<p>Disengage the motor from the drive unit before remove the worn parts of the conveyor chain.</p>
<p>Step 3</p> 	<p>Split the chain by removing the pin using the pin insertion/ removal tool.</p>
<p>Step 4</p> 	<p>Pull out the conveyor chain.</p>

Checking the condition of the slide rail

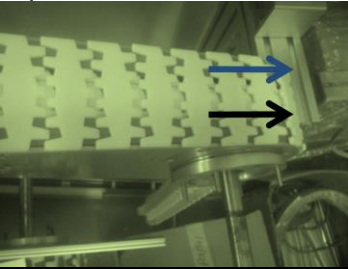
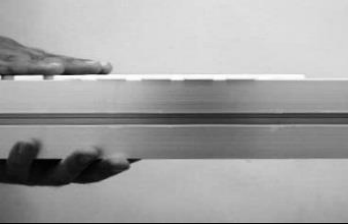
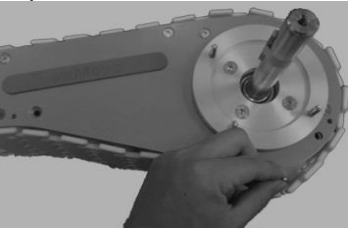
Run a sample chain (approx. 0.3m) of the conveyor chain through the conveyor. Make sure that the side rails on the conveyor beam are in good condition.

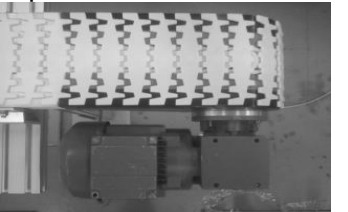
<p>Step 1</p> 	<p>The sample chain is install on the conveyor beam to make sure that it can moves easily and correctly through the bends and idler ends.</p>
<p>Step 2</p> 	<p>Make sure that the chain direction is corresponding to the conveyor direction.</p>
<p>Step 3</p> 	<p>Feed the chain along the conveyor by pulling it through the idler unit and back to the drive unit.</p>
<p>Step 4</p> 	<p>Tension the chain and remove links if necessary, so that the chain will exhibit some slack at the drive unit. Put in the stainless steel pin at the hole provided at drive unit and join the chain.</p>
<p>Step 5</p> 	<p>After install the conveyor chain, it is possible to test the chain by the hand without the motor.</p>
<p>Step 6</p> 	<p>The motor will be installed for test run after the final checking for the chain.</p>

For Direct Drive Tails:

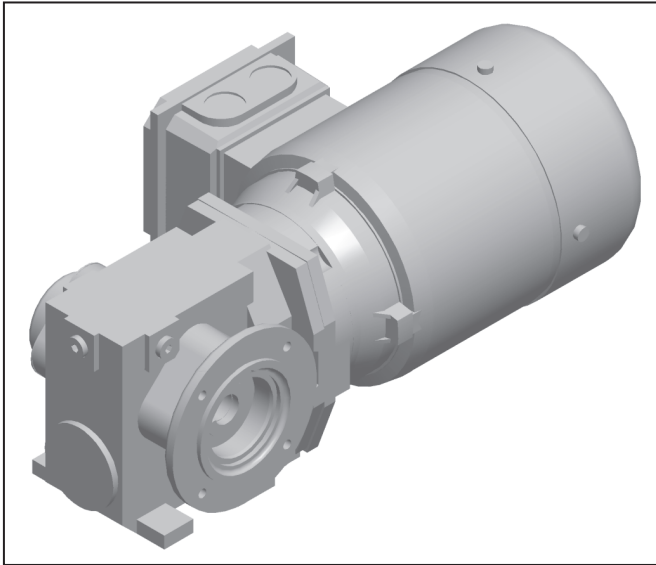

Product Line		FK,FS,FM,FU,FV	FC,FL	FS	FM
Radius (M)		0.064	0.0675	0.044	0.049
Drive Type		Direct	Direct	Intermediate	Intermediate
Part Number					
Right Hand	Left Hand	Speed	Speed	Speed	Speed
FMM129RDS423EN	FMM129LDS423EN	5.2 m/min	5.5 m/min	3.6 m/min	4 m/min
FMM067RDS423EN	FMM067LDS423EN	10 m/min	10.6 m/min	6.9 m/min	7.7 m/min
FMM032RDS423EN	FMM032LDS423EN	21.3 m/min	22.5 m/min	14.6 m/min	16.3 m/min
FMM015RDS423EN	FMM015LDS423EN	45.8 m/min	48.3 m/min	31.5 m/min	35.1 m/min
FMM013RDS423EN	FMM013LDS423EN	52.2 m/min	55.1 m/min	35.9 m/min	40 m/min
FMM010RDS423EN	FMM010LDS423EN	68.7 m/min	72.5 m/min	47.3 m/min	52.6 m/min

Part Number	Volts	Phase	Hz	Power	Power	Speed	Torque	Torque	Ratio	Force
FMM129(X)DS423EN	230/460	3	60	0.18 kW	0.25 Hp	13 rpm	95 Nm	837 in-lb.	129 i	1484 N
FMM067(X)DS423EN	230/460	3	60	0.37 kW	0.50 Hp	25 rpm	79 Nm	699 in-lb.	67.5 i	1234 N
FMM032(X)DS423EN	230/460	3	60	0.55 kW	0.75 Hp	53 rpm	74 Nm	653 in-lb.	32.3 i	1156 N
FMM015(X)DS423EN	230/460	3	60	0.55 kW	0.75 Hp	114 rpm	39 Nm	341 in-lb.	15 i	609 N
FMM013(X)DS423EN	230/460	3	60	0.75 kW	1.00 Hp	130 rpm	48 Nm	425 in-lb.	13.3 i	750 N
FMM010(X)DS423EN	230/460	3	60	1.1 kW	1.50 Hp	171 rpm	56 Nm	490 in-lb.	10.2 i	875 N

(X) = L or R for Right Hand or Left Hand Gearmotor matching RH or LH Drive

Note: speed range for 60 Hz gearmotors is 10 to 60 Hz or 6:1.

For Suspended Drive Tails:

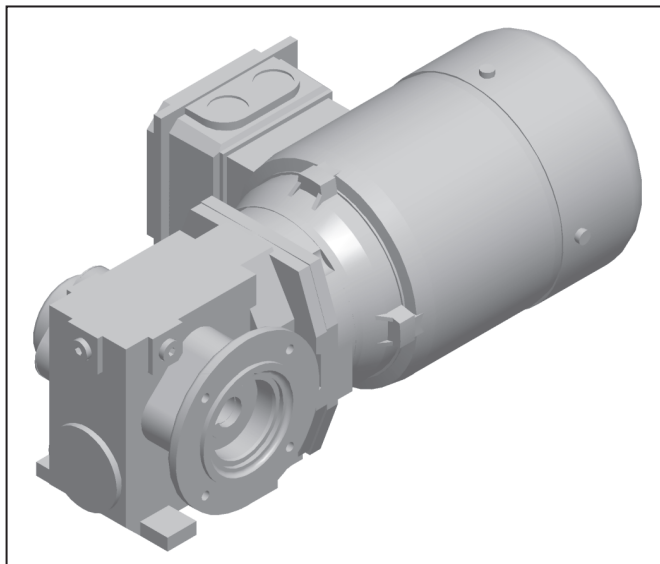

Product Line		FK,FS,FM,FU,FV	FC,FL
Radius (M)		0.064	0.0675
Drive Type		Suspended	Suspended
Part Number			
Right Hand	Left Hand	Speed	Speed
FMM129RSS423EN	FMM129LSS423EN	5.2 m/min	5.5 m/min
FMM067RSS423EN	FMM067LSS423EN	10 m/min	10.6 m/min
FMM032RSS423EN	FMM032LSS423EN	21.3 m/min	22.5 m/min
FMM015RSS423EN	FMM015LSS423EN	45.8 m/min	48.3 m/min
FMM013RSS423EN	FMM013LSS423EN	52.2 m/min	55.1 m/min
FMM010RSS423EN	FMM010LSS423EN	68.7 m/min	72.5 m/min

Part Number	Volts	Phase	Hz	Power	Power	Speed	Torque	Torque	Ratio	Force
FMM129(X)SS423EN	230/460	3	60	0.18 kW	0.25 Hp	13 rpm	95 Nm	837 in-lb.	129 i	1484 N
FMM067(X)SS423EN	230/460	3	60	0.37 kW	0.50 Hp	25 rpm	79 Nm	699 in-lb.	67.5 i	1234 N
FMM032(X)SS423EN	230/460	3	60	0.55 kW	0.75 Hp	53 rpm	74 Nm	653 in-lb.	32.3 i	1156 N
FMM015(X)SS423EN	230/460	3	60	0.55 kW	0.75 Hp	114 rpm	39 Nm	341 in-lb.	15 i	609 N
FMM013(X)SS423EN	230/460	3	60	0.75 kW	1.00 Hp	130 rpm	48 Nm	425 in-lb.	13.3 i	750 N
FMM010(X)SS423EN	230/460	3	60	1.1 kW	1.50 Hp	171 rpm	56 Nm	490 in-lb.	10.2 i	875 N

(X) = L or R for Right Hand or Left Hand Gearmotor matching RH or LH Drive

Note: speed range for 60Hz gearmotors is 10 to 60 Hz or 6:1.

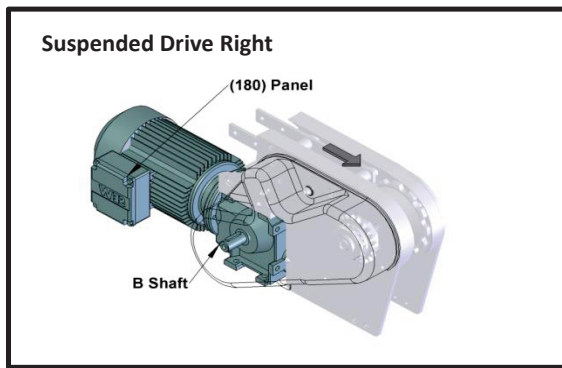
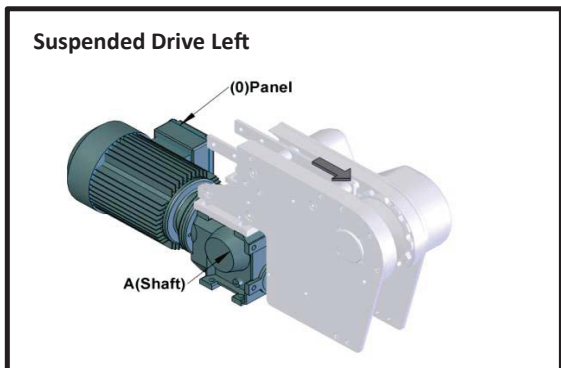
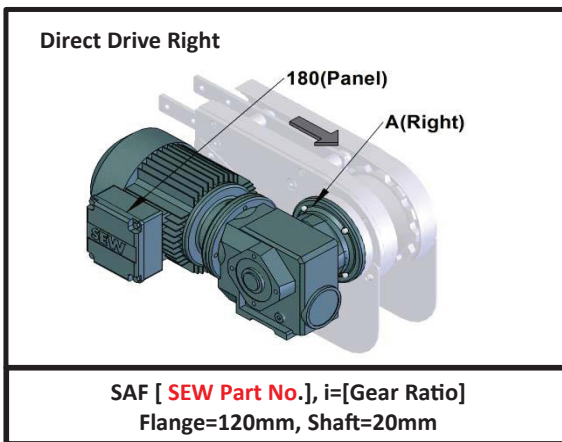
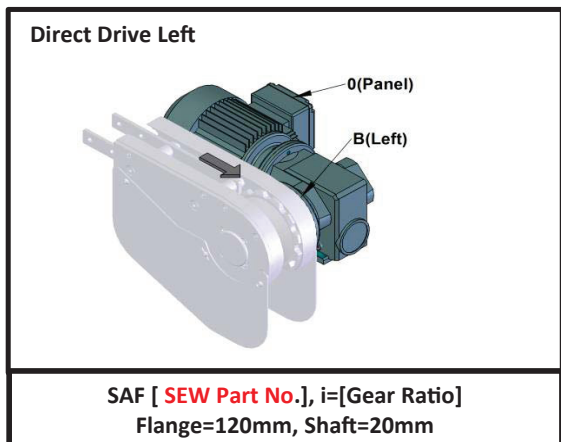

37 series, Flange D:120mm, Shaft: 20mm

Speed	Gear Ratio	Speed *	Torque	Power,	SAF - Direct Drive	S - Suspended Drive	Est. Traction Force, N	Weight	Radius, r	Motor (L)	Shaft Dia.
m/min	i	rpm	Nm	KW	Sprocket Dia. = 130mm	Sprocket Dia. = 130mm					
4	157.43	8.8	74	0.12	SAF37DR63S4	S37DR63S4	1025	12	0.065	389	20
5	106.00	13	52	0.12	SAF37DR63S4	S37DR63S4	720	12	0.065	389	20
6	98.80	14	49	0.12	SAF37DR63S4	S37DR63S4	678	12	0.065	389	20
7	71.44	18	58	0.18	SAF37DR63M4	S37DR63M4	803	12	0.065	389	20
9	63.33	21	55	0.18	SAF37DR63M4	S37DR63M4	762	12	0.065	389	20
10	55.93	24	52	0.18	SAF37DR63M4	S37DR63M4	720	12	0.065	389	20
11	51.30	26	51	0.18	SAF37DR63M4	S37DR63M4	706	12	0.065	389	20
12	43.68	30	44	0.18	SAF37DR63M4	S37DR63M4	609	12	0.065	389	20
14	37.66	35	54	0.25	SAF37DR63L4	S37DR63L4	748	13	0.065	389	20
15	35.10	37	51	0.25	SAF37DR63L4	S37DR63L4	706	13	0.065	389	20

* Maximum Traction Force = **500N** for FK, FS (Always set limit value of driving current or torque limiter)

FlexMove® standard drive shaft is 20mm and Flange is 120mm diameter mounting.

Kindly inform any non-standard drive shaft and flange diameter upon order.

SEW Helical-Worm Geared Motors are products of SEW-Eurodrive®

FlexMove reserves the right to make alteration without prior notification. Every care has been taken up to ensure the accuracy of the information contained in this catalogue but no liability can be accepted for any error or omissions.

* NOTE : Chain speeds shown are for 50Hz gearmotors.
For 60Hz gearmotor multiply by 1.2%

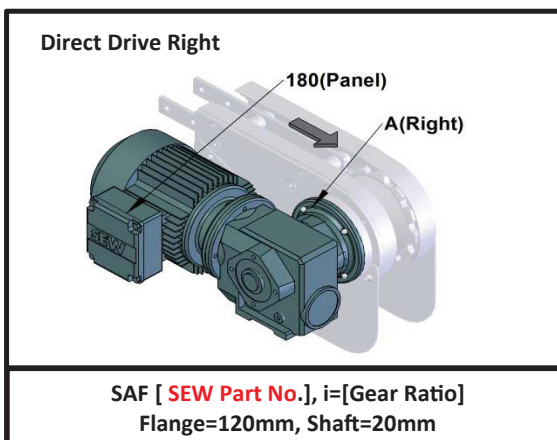
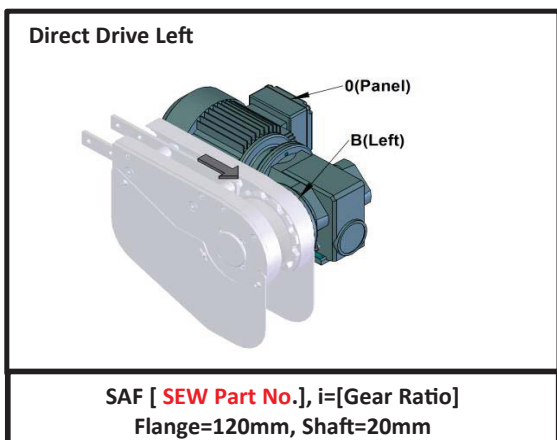

37 series, Flange D:120mm, Shaft: 20mm

Speed	Gear Ratio	Speed *	Torque	Power,	SAF - Direct Drive	S - Suspended Drive	Est. Traction Force, N	Weight	Radius, r	Motor (L)	Shaft Dia.
m/min	i	rpm	Nm	KW	Sprocket Dia. = 130mm	Sprocket Dia. = 130mm					
17	30.68	42	45	0.25	SAF37DR63L4	S37DR63L4	623	13	0.065	389	20
18	28.76	45	42	0.25	SAF37DR63L4	S37DR63L4	582	13	0.065	389	20
19	28.76	48	59	0.37	SAF37DT71D4	S37DT71D4	817	13	0.065	413	20
22	25.38	54	52	0.37	SAF37DT71D4	S37DT71D4	720	13	0.065	413	20
25	22.50	61	47	0.37	SAF37DT71D4	S37DT71D4	651	13	0.065	413	20
28	19.89	69	44	0.37	SAF37DT71D4	S37DT71D4	609	13	0.065	413	20
31	18.24	76	41	0.37	SAF37DT71D4	S37DT71D4	568	13	0.065	413	20
36	15.53	88	53	0.55	SAF37DT80K4	S37DT80K4	734	15	0.065	463	20
41	13.39	102	46	0.55	SAF37DT80K4	S37DT80K4	637	15	0.065	463	20
44	12.48	109	43	0.55	SAF37DT80K4	S37DT80K4	595	15	0.065	463	20
51	10.91	125	37	0.55	SAF37DT80K4	S37DT80K4	512	15	0.065	463	20
52	10.91	127	50	0.75	SAF37DT80N4	S37DT80N4	692	16	0.065	463	20
54	10.23	133	35	0.55	SAF37DT80K4	S37DT80K4	485	15	0.065	463	20
55	10.23	135	47	0.75	SAF37DT80N4	S37DT80N4	651	16	0.065	463	20
62	9.02	153	42	0.75	SAF37DT80N4	S37DT80N4	582	16	0.065	463	20
70	8.00	173	37	0.75	SAF37DT80N4	S37DT80N4	512	16	0.065	463	20

* Maximum Traction Force = **500N** for FK, FS (Always set limit value of driving current or torque limiter)

FlexMove® standard drive shaft is 20mm and Flange is 120mm diameter mounting.

Kindly inform any non-standard drive shaft and flange diameter upon order.

SEW Helical-Worm Geared Motors are products of SEW-Eurodrive®

FlexMove reserves the right to make alteration without prior notification. Every care has been taken up to ensure the accuracy of the information contained in this catalogue but no liability can be accepted for any error or omissions.

* NOTE : Chain speeds shown are for 50Hz gearmotors.

For 60Hz gearmotor multiply by 1.2%

(2) versions of Drive Modules have been produced. You need to determine which module version you have before ordering service parts.

To determine if you have a Standard Tail or a Cast Tail look for a slot on the tail plate.

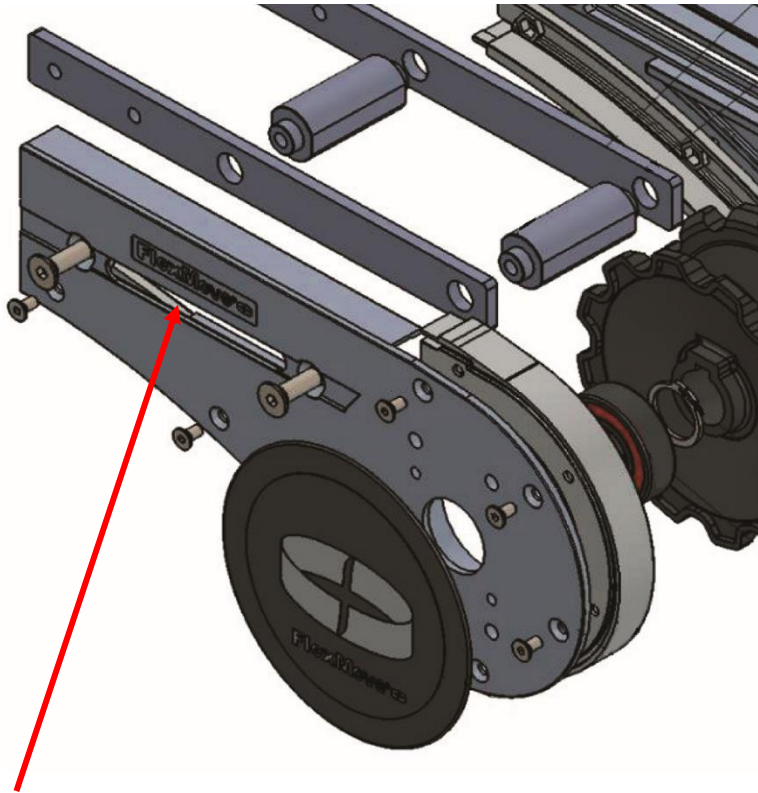

No slot = Standard Tail
Slot = Cast Tail

FKD44100-20
Sprocket width W = 30mm

Part No : FKDL-20

FKDD-0L1 /0R1 Drive Kits

ITEM	DESCRIPTION	DWG. NO	QTY
1	FKD DRIVE SPROCKET	FKD44100-20	1
2	6904 BEARING HOUSING	B6904-C70	2
3	FKD DRIVE SHAFT	FK44106	1
4	NTN BEARING	6904ZZ	2
5	CIRCLIP D-1400 A20		2
6	M6X39 KEYWAY		1

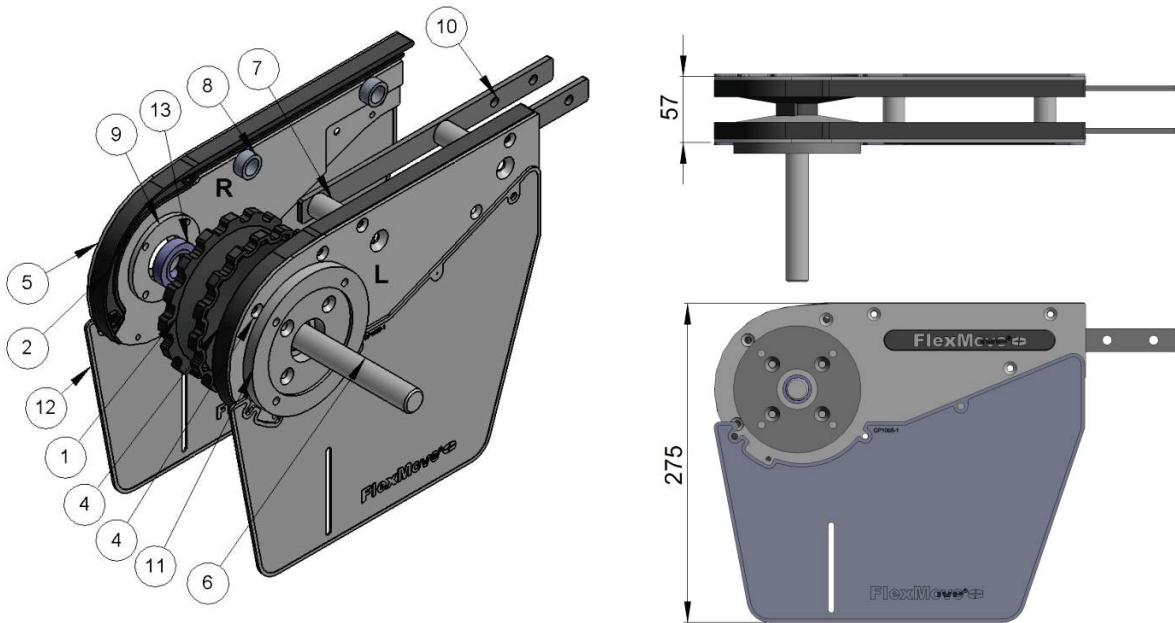
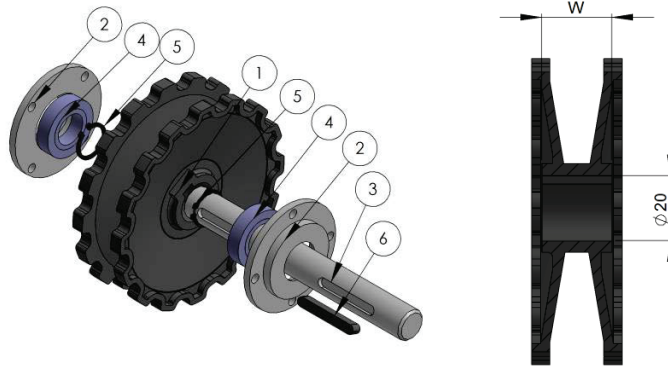

ITEM	DESCRIPTION	DWG. NO	QTY	Recommended Spare parts
1	FKD DRIVE SPROCKET	FKD44100-20	1	X
2	FKD STEERING GUIDE RIGHT/LEFT	FKD44101	1 Set	X
3	FKD RETURN STEERING GUIDE R/L	FKD44102	1 Set	X
4	FKDD SIDE PLATE LEFT	FK44101-1	1	
5	FKDD SIDE PLATE RIGHT	FK44101-1	1	
6	FKD DRIVE SHAFT	FK44106	1	
7	FKD PILLAR	FK44107	2	
8	DRIVE SPACER	FASP-22X9.4	4	
9	6904 BEARING HOUSING	B6904-C70	2	
10	DRIVE CONNECTING STRIP	FACS20-L259	2	
11	WA120MM FLANGE PLATE	FLGWA30-120-2	1	
12	SAFETY COVER	CP1005-1	2	
13	NTN BEARING	6904ZZ	2	
14	N/A	N/A	N/A	

Part No : FKIM-15

FKIE45-200 Idler Kits

ITEM	DESCRIPTION	DWG. NO	QTY
1	FKE IDLER WHEEL	FKE44000	1
2	FKE WHEEL SHAFT	FKE44202	1
3	NTN BEARING	6202 ZZ	2
4	CIRCLIP D-1400 A15		2

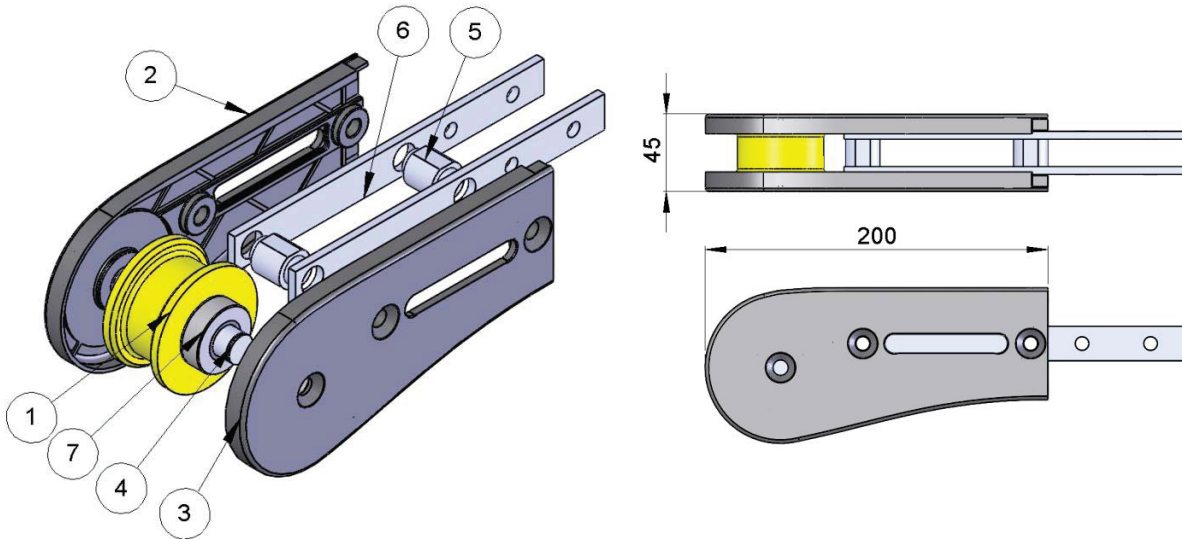
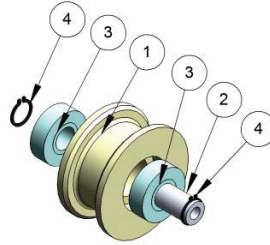

ITEM	DESCRIPTION	DWG. NO	QTY	Recommended Spare parts
1	FKE IDLER WHEEL	FIE201	1	X
2	FKE SIDE PLATE RIGHT	FIE200-K	1	
3	FKE SIDE PLATE LEFT	FIE200-K	1	
4	FKE WHEEL SHAFT	FKE44202	1	
5	FKE PILLAR	FKE44203	2	
6	FKE CONNECTING STRIP	FACS20-L199	2	
7	NTN BEARING	6202 ZZ	2	

F?SD-0L1 /'0R1 Suspended Drive



Part No : FKDS-20

FKSD-0L1 / 0R1 Drive Kits

FKD44100-20
Sprocket width W = 30mm

ITEM	DESCRIPTION	DWG. NO	QTY
1	FKD DRIVE SPROCKET	FKD44100-20	1
2	6904 BEARING HOUSING	B6904-C70	2
3	FKSD DRIVE SHAFT	FK44306	1
4	NTN BEARING	6904ZZ	2
5	CIRCLIP D-1400 A20		2
6	M6X20 KEYWAY		1

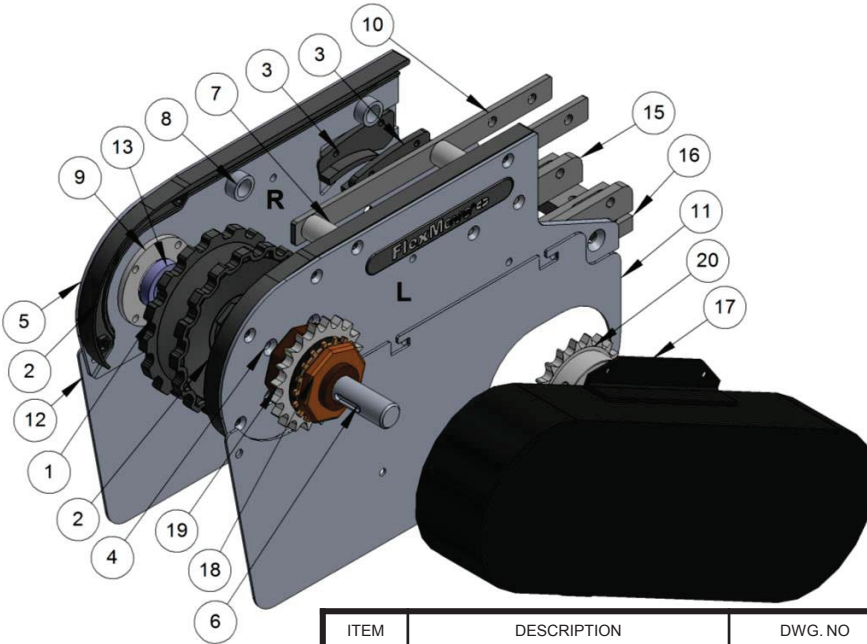
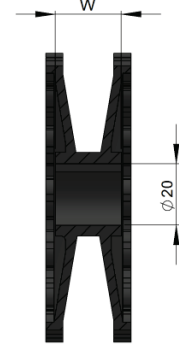
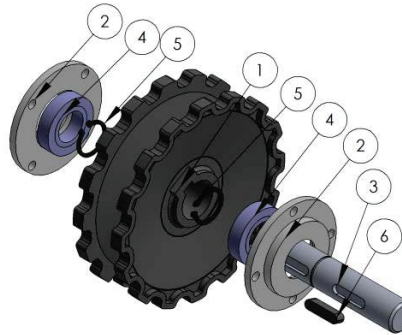

ITEM	DESCRIPTION	DWG. NO	QTY	Recommended Spare parts
1	FKD DRIVE SPROCKET	FKD44100-20	1	X
2	FKD STEERING GUIDE RIGHT/LEFT	FKD44101	1 Set	X
3	FKD RETURN STEERING GUIDE R/L	FKD44102	1 Set	X
4	FKSD SIDE PLATE LEFT	FK44301-1	1	
5	FKSD SIDE PLATE RIGHT	FK44301-1	1	
6	FKSD DRIVE SHAFT	FK44306	1	
7	FKSD PILLAR	FK44302	2	
8	DRIVE SPACER	FASP-22X9.4	4	
9	6904 BEARING HOUSING	B6904-C70	2	
10	DRIVE CONNECTING STRIP	FACS20-L259	2	
11	DRIVE SAFETY COVER	CP1010	1	
12	SLACK PROTECTION COVER	CP1011	1	
13	NTN BEARING	6904ZZ	2	
14	N/A	N/A	N/A	
15	LR BRACKET	CP1002-3	2	
16	GEAR MOTOR MOUNTING BRACKET	CP1013	2	
17	TRANSMISSION CHAIN COVER	CP1004-300L-1	1	
18	TORQUE LIMITER	TL-250-2	1	X
19	TRANSMISSION SPROCKET-TL-250	RS08BX19T-41F	1	X
20	TRANSMISSION SPROCKET	RS08BX19T-20	1	X

FKD44503
Sprocket width W = 30mm

Part No : FKIDL-20

FKID-DD-0L1 /0R1 Drive Kits

ITEM	DESCRIPTION	DWG. NO	QTY
1	FKID DRIVE SPROCKET	FKD44503	1
2	6904 BEARING HOUSING	B6904-C70	2
3	FKD DRIVE SHAFT	FK44106	1
4	NTN BEARING	6904ZZ	2
5	CIRCLIP D-1400 A20		2
6	M6X39 KEYWAY		1

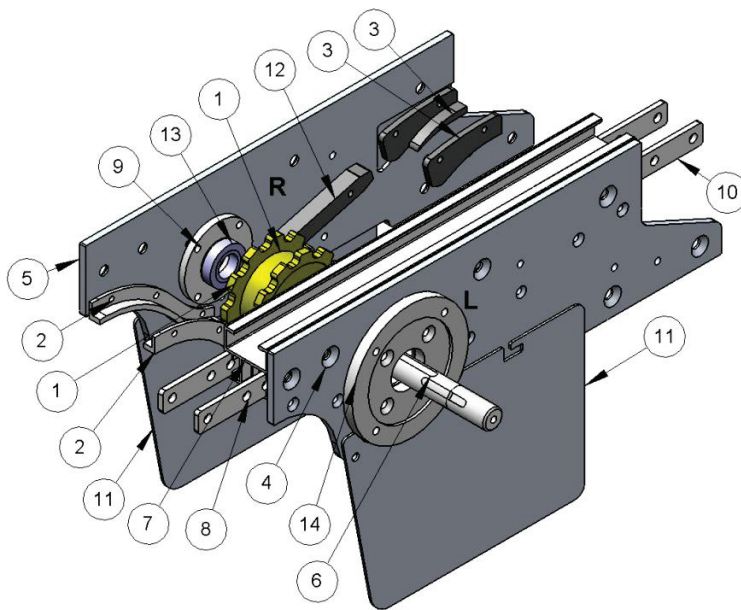
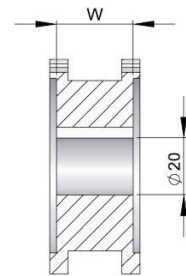
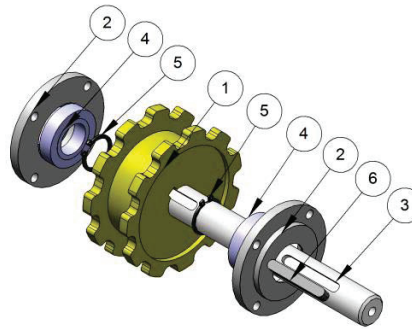

ITEM	DESCRIPTION	DWG. NO	QTY	Recommended Spare parts
1	FKID DRIVE SPROCKET	FKD44503	1	X
2	FKID STEERING GUIDE RIGHT/LEFT	FKD44504-1	1 Set	X
3	FKD RETURN STEERING GUIDE R/L	FKD44102	1 Set	X
4	FKID SIDE PLATE LEFT	FK44501	1	
5	FKID SIDE PLATE RIGHT	FK44501	1	
6	FKD DRIVE SHAFT	FK44106	1	
7	FKID BED	FK44502	1	
8	CONNECTING STRIP	FACS-20x140	2	
9	6904 BEARING HOUSING	B6904-C70	2	
10	DRIVE CONNECTING STRIP	FACS20-L259xM8	2	
11	SLACK PROTECTION COVER	CP1011	2	
12	RETURN CHAIN PROTECTOR	CP1012-K	2	
13	NTN BEARING	6904ZZ	2	
14	WA120MM FLANGE PLATE	FLGWA30-120-2	1	

F?ID-SD-0L1 /0R1 Intermediate Suspended Drive



Part No : FKIDS-20

FKD44503
Sprocket width W = 30mm

FKID-SD-0L1 /0R1 Drive Kits

ITEM	DESCRIPTION	DWG. NO	QTY
1	FKID DRIVE SPROCKET	FKD44503	1
2	6904 BEARING HOUSING	B6904-C70	2
3	FKSD DRIVE SHAFT	FK44306	1
4	NTN BEARING	6904ZZ	2
5	CIRCLIP D-1400 A20		2
6	M6X39 KEYWAY		1

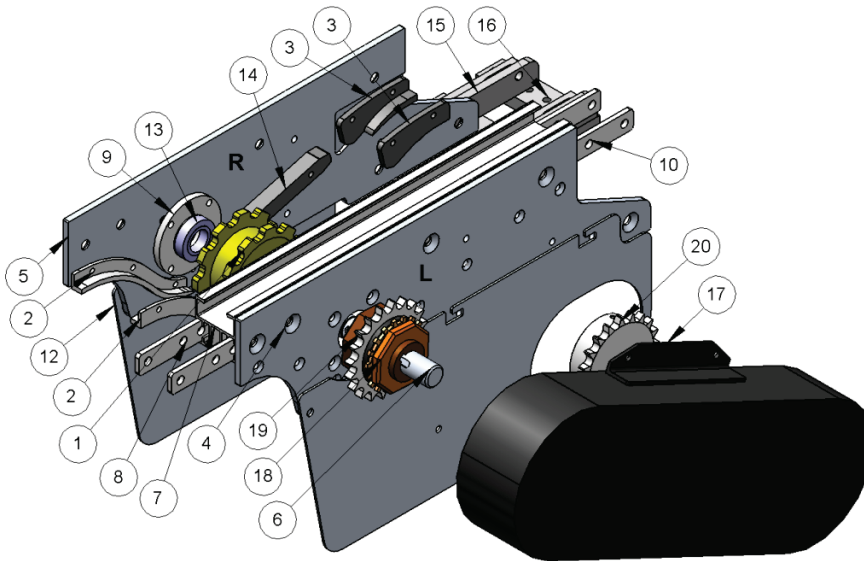
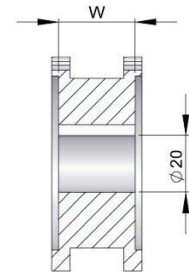
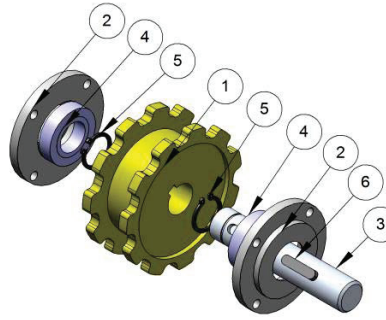

ITEM	DESCRIPTION	DWG. NO	QTY	Recommended Spare parts
1	FKID DRIVE SPROCKET	FKD44503	1	X
2	FKID STEERING GUIDE RIGHT/LEFT	FKD44504-1	1 Set	X
3	FKD RETURN STEERING GUIDE R/L	FKD44102	1 Set	X
4	FKID SIDE PLATE LEFT	FK44501	1	
5	FKID SIDE PLATE RIGHT	FK44501	1	
6	FKSD DRIVE SHAFT	FK44306	1	
7	FKID BED	FK44502	1	
8	CONNECTING STRIP	FACS-20x140	2	
9	6904 BEARING HOUSING	B6904-C70	2	
10	DRIVE CONNECTING STRIP	FACS20-L259xM8	2	
11	DRIVE SAFETY COVER	CP1010	1	
12	SLACK PROTECTION COVER	CP1011	1	
13	NTN BEARING	6904ZZ	2	
14	RETURN CHAIN PROTECTOR	CP1012-K	2	
15	LR BRACKET	CP1002-3	2	
16	GEAR MOTOR MOUNTING BRACKET	CP1013	2	
17	TRANSMISSION CHAIN COVER	CP1004-300L-1	1	
18	TORQUE LIMITER	TL-250-2	1	X
19	TRANSMISSION SPROCKET-TL-250	RS08BX19T-41F	1	X
20	TRANSMISSION SPROCKET	RS08BX19T-20	1	X

Return Policy

Returns must have prior written factory authorization or they will not be accepted. Items that are returned to Dorner without authorization will not be credited nor returned to the original sender. When calling for authorization, please have the following information ready for the Dorner factory representative or your local distributor:

1. Name and address of customer.
2. Dorner part number(s) of item(s) being returned.
3. Reason for return.
4. Customer's original order number used when ordering the item(s).
5. Dorner or distributor invoice number (if available, part serial number).

A representative will discuss action to be taken on the returned items and provide a Returned Goods Authorization (RMA) number for reference. RMA will automatically close 30 days after being issued. To get credit, items must be new and undamaged. There will be a return charge on all items returned for credit, where Dorner was not at fault. It is the customer's responsibility to prevent damage during return shipping. Damaged or modified items will not be accepted. The customer is responsible for return freight.

Product Type									
Standard Products									Engineered to order parts
Product Line	Conveyors	Gearmotors & Mounting Packages	Support Stands	Accessories	Spare Parts (non-belt)	Spare Belts - Standard Flat Fabric	Spare Belts - Cleated & Specialty Fabric	Spare Belts - Plastic Chain	All equipment and parts
1100	30% return fee for all products except: 50% return fee for conveyors with modular belt, cleated belt or specialty belts						non-returnable		case-by-case
2200									
2200 Modular Belt									
2200 Precision Move									
2300									
2300 Modular Belt									
3200									
3200 LPZ									
3200 Precision Move									
4100									
5200									
5300									
6200									
Controls									
7200 / 7300	50% return fee for all products								
7350	non-returnable								
7360									
7400									
7600									

Returns will not be accepted after 60 days from original invoice date. The return charge covers inspection, cleaning, disassembly, disposal and reissuing of components to inventory. If a replacement is needed prior to evaluation of returned item, a purchase order must be issued. Credit (if any) is issued only after return and evaluation is complete.

Dorner has representatives throughout the world. Contact Dorner for the name of your local representative. Our Customer Service Team will gladly help with your questions on Dorner products.

For a copy of Dorner's Warranty, contact factory, distributor, service center or visit our website at www.dorner.com.

For replacement parts, contact an authorized Dorner Service Center or the factory.

 <p>Dorner Mfg. Corp. reserves the right to change or discontinue products without notice. All products and services are covered in accordance with our standard warranty. All rights reserved. © Dorner Mfg. Corp. 2015</p>	<p>DORNER MFG. CORP. 975 Cottonwood Ave., PO Box 20 Hartland, WI 53029-0020 USA TEL 1-800-397-8664 (USA) FAX 1-800-369-2440 (USA) Internet: www.dorner.com</p>	<p>Outside the USA: TEL 1-262-367-7600 FAX 1-262-367-5827</p>
---	--	---