

Complex Configurations
that Assemble in a Snap

High Speed Performance
- Up to 76 mpm

Reduces
Conveyor Footprint

Ideal for Curves,
Inclines & Declines

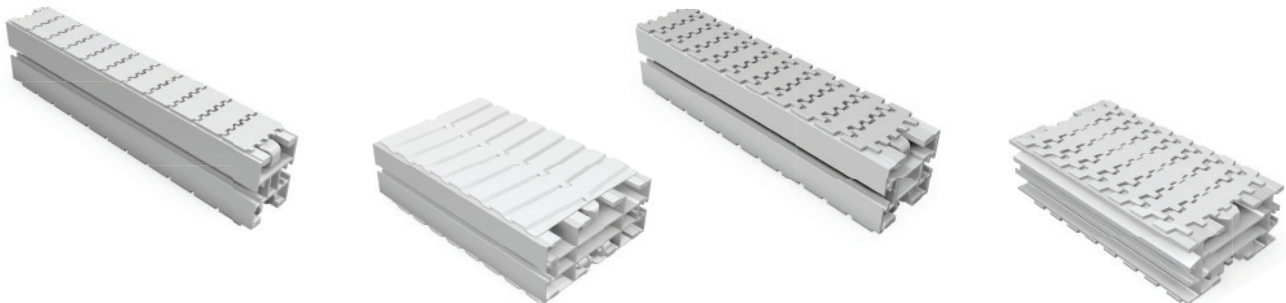
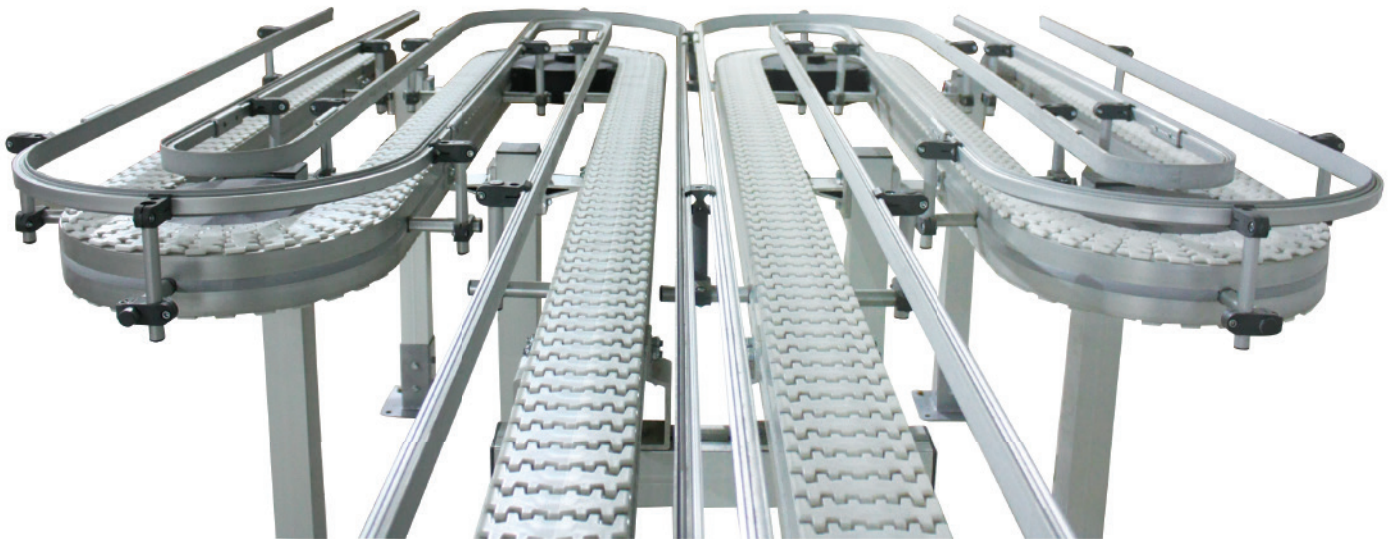

FlexMove®

Aluminum Flexible Chain Conveyors



FlexMove® Conveyors are best for:

- Part Handling
- Transfers
- Tight Spaces
- Elevation Changes
- Accumulation
- Buffering
- Complex Configurations
- Long Lengths
- Curves, Jogs, Incline, Decline

Sizes & Measurements

- 44 mm, 63 mm, 83 mm, 103 mm, 150 mm, 180 mm & 260 mm (widths)
- 0.6 m to 29.8 m (lengths)

Loads & Speeds

- Up to 272 kgs
- Up to 76 meters per minute

Plastic Chain Types

- Standard: Low Friction & Friction Top Inserts
- Specialty
 - Conductive
 - Cleated
 - Roller Top
 - Magnet Top
 - And Many More

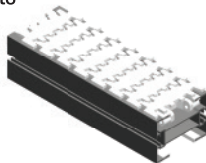

Flat

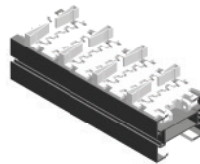

Cleated

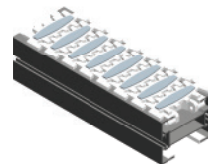

Friction Top

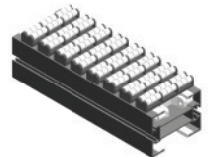

Roller Top

Modules

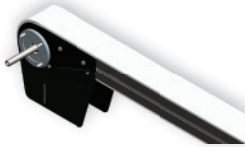

Drive



Idler



Curve
from 15° to 180°



Incline/Decline
from 5° to 90°



Guiding

- Fully Adjustable Single Rail
- Fully Adjustable Double Rail
- Other Options Available



Support Stands

- Single, Double and Multi Lane Structures Available

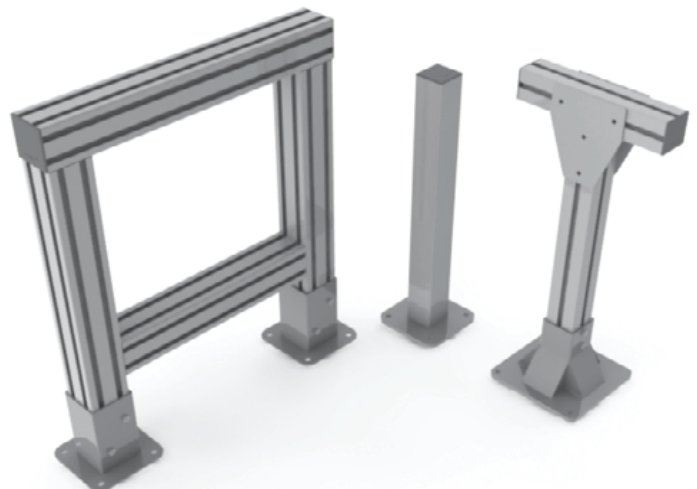

Alpines

- Ideal for inclines and declines in tight spaces
- Provides capability for vertical incline with minimal floor space
- Applications include accumulating, buffering and cooling product between processes or machines
- Serves as an in-line accumulator with entry and exit at different levels or an in-line or off-line accumulator with entry and exit at the same level



Helix

- Reduces conveyor footprint saving valuable floor space
- Allows incline or decline through corners and straights
- Patented side roller chain reduces corner friction
- Provides capability for product buffering or storage for accumulation or cooling
- Provides capability for vertical incline with minimal floor space use
- Simple, low cost Spiral for small parts handling



Helical Curve

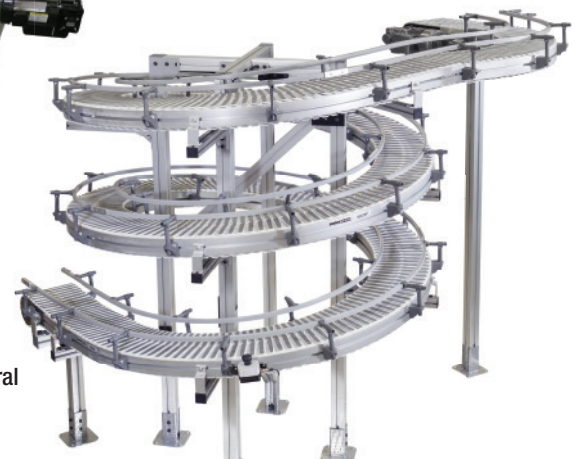

Spiral

Wedge Elevators



- Specialty chain designed to securely convey a product by gripping the sides
- Saves footprint space by vertically lifting or lowering a product
- Built with aluminum and stainless steel to meet the stringent hygiene standards required for medical and cosmetic packaging.

The Benefits of a FlexMove® Conveyor

- Horizontal and Vertical Product Movement Capabilities for Maximizing Space
- Flexibility of Layouts and Design
- Cost Effective Solutions
- Clean, Sleek Designs with Minimal Noise, Maintenance and Weight
- Multiple Chain Types to Match Your Products and Application Requirements

Transforming Conveyor Automation

Industrial & Automation Conveyors

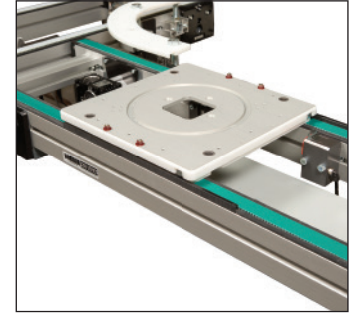
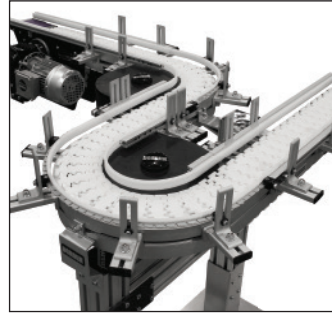
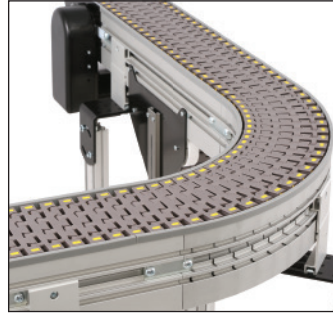

Sanitary Conveyors

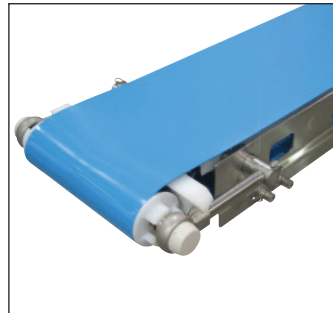
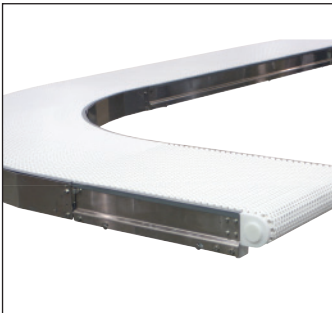

Engineered Solutions

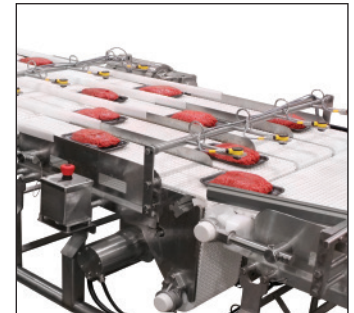
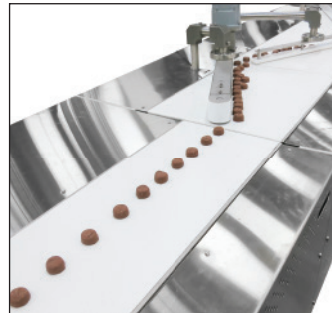

Parts



Service



Online Configurator



Warranty

www.dorner.com



Dorner – North & South America

Dorner – U.S.A. Headquarters

975 Cottonwood Ave
Hartland, WI 53029, USA
(800) 397-8664
(262) 367-7600
info@dorner.com

Dorner – Canada

100-5515 North Service Road
Burlington, Ontario L7L 6G6
Canada
(289) 208-7306
info@dorner.com

Dorner – Latin America

Carretera a Nogales #5297, Nave 11.
Parque Industrial Nogales
Zapopan, Jalisco C.P. 45222 México
+52.33.30037400 | info.latinamerica@dorner.com

Dorner – Europe

Karl-Heinz-Beckurts-Straße 7
52428 Jülich, Germany
+49 (0) 2461/93767-0 | info.europe@dorner.com

Dorner – Asia

128 Jalan Permatang Damar Laut, Bayan Lepas 11960
Penang, Malaysia
+604-626-2948 | info.asia@dorner.com

