



7350 Series Version 2 Nose Bar Drive Package

Installation, Maintenance & Parts Manual



For other service manuals visit our website at:
www.dornerconveyors.com/manuals-literature

Record Conveyor Serial Number Here

Warnings - General Safety

⚠ WARNING

The safety alert symbol, black triangle with white exclamation, is used to alert you to potential personal injury hazards.

⚠ DANGER



Climbing, sitting, walking or riding on conveyor will cause severe injury.
KEEP OFF CONVEYORS.

⚠ DANGER



DO NOT OPERATE CONVEYORS IN AN EXPLOSIVE ENVIRONMENT.

⚠ WARNING



SEVERE HAZARD!

LOCK OUT POWER before removing guards or performing maintenance. Exposed moving parts can cause serious injury.

⚠ WARNING



BURN HAZARD!

DO NOT TOUCH the motor while operating, or shortly after being turned off. Motors may be **HOT** and can cause serious burn injuries.

⚠ WARNING



Exposed moving parts can cause severe injury.
REPLACE ALL GUARDS BEFORE RUNNING CONVEYOR.

⚠ WARNING



Dorner cannot control the physical installation and application of conveyors. Taking protective measures is the responsibility of the user.

When conveyors are used in conjunction with other equipment or as part of a multiple conveyor system, **CHECK FOR POTENTIAL PINCH POINTS** and other mechanical hazards before system start-up.

⚠ WARNING



PUNCTURE HAZARD!

Handle drive shaft keyway with care. It may be sharp and could puncture the skin, causing serious injury.

⚠ WARNING



CRUSH HAZARD!

- **SUPPORT MOTOR PRIOR TO LOOSENING THE BOLTS**
- Loosening motor bolts may cause it to drop down, causing serious injury.

Product Description

Refer to **(Figure 1)** for typical garmotor assembly components.

1	Mounting Bracket
2	Motor
3	Gear Reducer

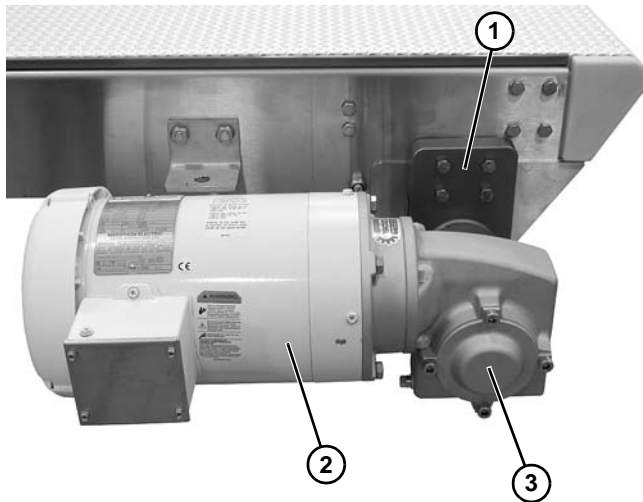

Figure 1

Installation

Nose Bar Drive Package

Required Tools

- 3/16" hex wrench
- 8 mm hex wrench
- 5/16" wrench
- 4 mm wrench
- 13 mm wrench
- 14 mm wrench
- Large flat head screwdriver
- Torque wrench

Typical Nose Bar Drive Package Components (**Figure 3**).

1	Gearmotor Assembly
2	3 Jaw Coupling (x2)
3	3 Jaw Rubber Spider
4	M8 Hex Head Cap Screw (x4)
5	Motor Mount
6	M8 Hex Head Cap Screw (x3)

⚠ WARNING



SEVERE HAZARD!
LOCK OUT POWER before removing guards or performing maintenance. Exposed moving parts can cause serious injury.

⚠ WARNING



PUNCTURE HAZARD!
 Handle drive shaft keyway with care. It may be sharp and could puncture the skin, causing serious injury.

NOTE

Gearmotor may be operated in positions 1 or 2 (Figure 2).

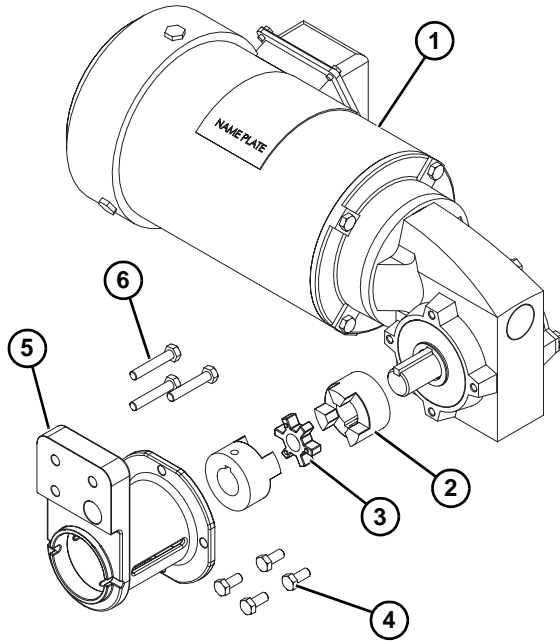

Figure 3

1. Install shaft key.
2. Attach three jaw coupling to shaft and tighten.



Figure 4

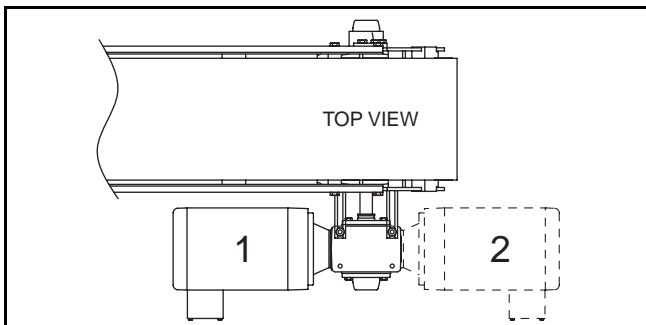

Figure 2

Installation

3. Remove three fasteners from conveyor, leaving the fourth fastener that lines up with the clearance hole on the motor mount.



Figure 5

4. Attach motor mount to the conveyor.

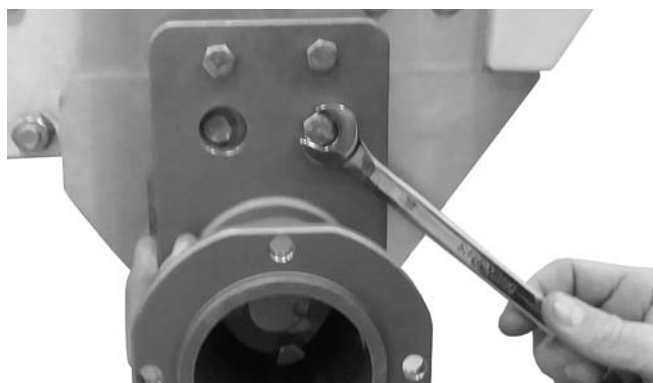

Figure 6

5. Insert spider bushing.

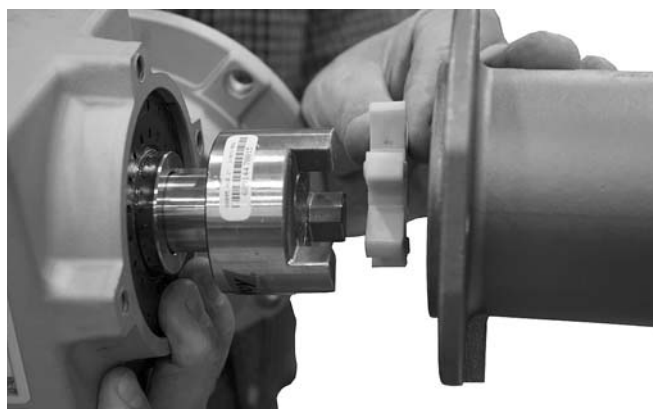

Figure 7

6. Attach gear reducer by aligning couplings.
7. Tighten bolts.

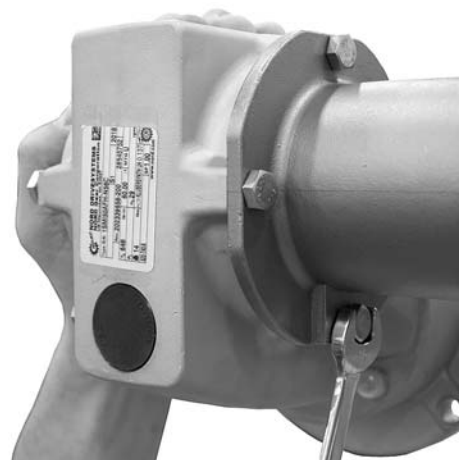

Figure 8

8. Install shaft key.
9. Install coupling (see label on coupling).



Figure 9

10. Install gearmotor to gear reducer.
11. Tighten bolts.



Figure 10

Preventive Maintenance and Adjustment

Required Tools

- 3/16" hex wrench
- 8 mm hex wrench
- 5/16" wrench
- 4 mm wrench
- 13 mm wrench
- 14 mm wrench
- Large flat head screwdriver
- Torque wrench

Check List

- Keep critical service parts on hand. Refer to “Service Parts” on page 9 for recommendations.
- Replace any worn or damaged parts.

Gear Reducer Replacement

⚠ WARNING

SEVERE HAZARD! LOCK OUT POWER before removing guards or performing maintenance. Exposed moving parts can cause serious injury.

⚠ WARNING

BURN HAZARD! DO NOT TOUCH the motor while operating, or shortly after being turned off. Motors may be HOT and can cause serious burn injuries.

⚠ WARNING

CRUSH HAZARD! <ul style="list-style-type: none">• SUPPORT MOTOR PRIOR TO LOOSENING THE BOLTS• Loosening motor bolts may cause it to drop down, causing serious injury.

1. Remove gearmotor from gear reducer.



Figure 11

2. Remove gear reducer from mounting bracket.

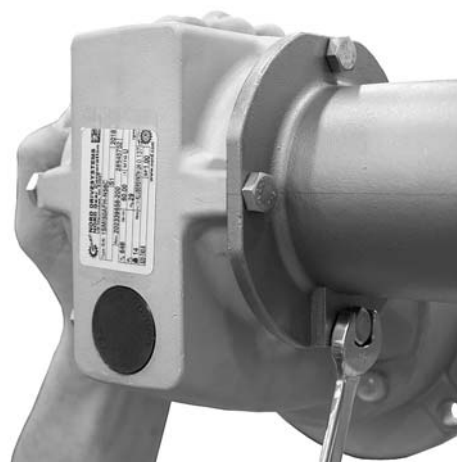

Figure 12

Preventive Maintenance and Adjustment

3. Remove three jaw coupling.

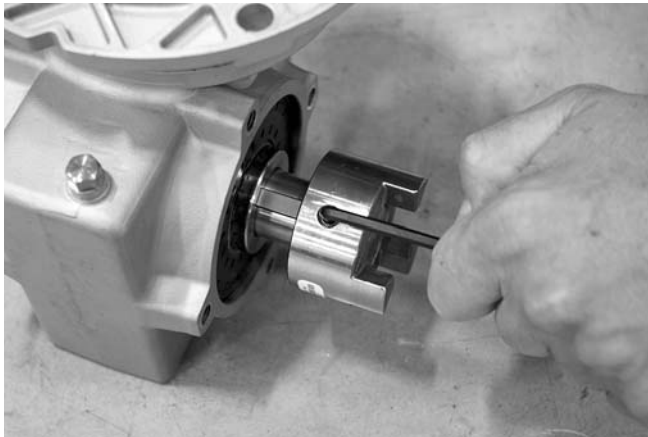

Figure 13

6. Remove snap ring.

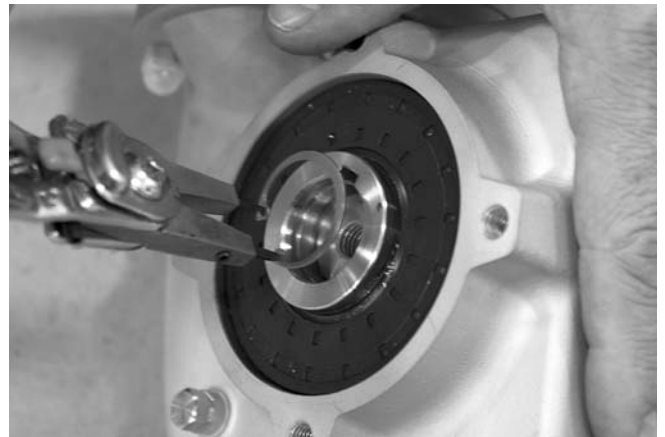

Figure 16

4. Remove four bolts and cover.



Figure 14

7. Remove shaft and shaft key.

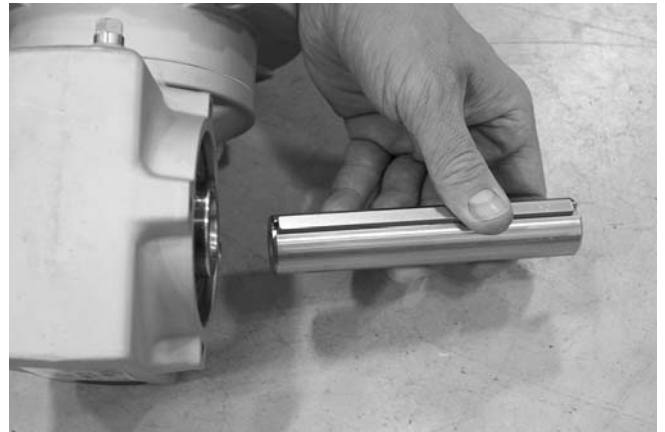

Figure 17

5. Remove bolt and washer from shaft.



Figure 15

8. Replace worn or damaged parts.
9. Install components in the reverse of removal.
10. Install gearmotor to gear reducer. Refer to "Nose Bar Drive Package" beginning on page 4. Complete steps 8 through 11.

Preventive Maintenance and Adjustment

Gearmotor Replacement

⚠ WARNING



SEVERE HAZARD!

LOCK OUT POWER before removing guards or performing maintenance. Exposed moving parts can cause serious injury.

⚠ WARNING



BURN HAZARD!

DO NOT TOUCH the motor while operating, or shortly after being turned off. Motors may be HOT and can cause serious burn injuries.

1. Loosen four bolts.



Figure 18

2. Remove gearmotor from gear reducer.



Figure 19

3. Install shaft key.
4. Install coupling (see label on coupling).
5. Install gearmotor to gear reducer.



Figure 20

6. Tighten four bolts.

NOTE

For replacement parts other than those shown in this section, contact an authorized Dornier distributor or Dornier directly. Recommended Critical Service Parts and Kits are identified by the Key Service Parts symbol . Dornier recommends keeping these parts on hand.

Nose Bar Mount Drive Package

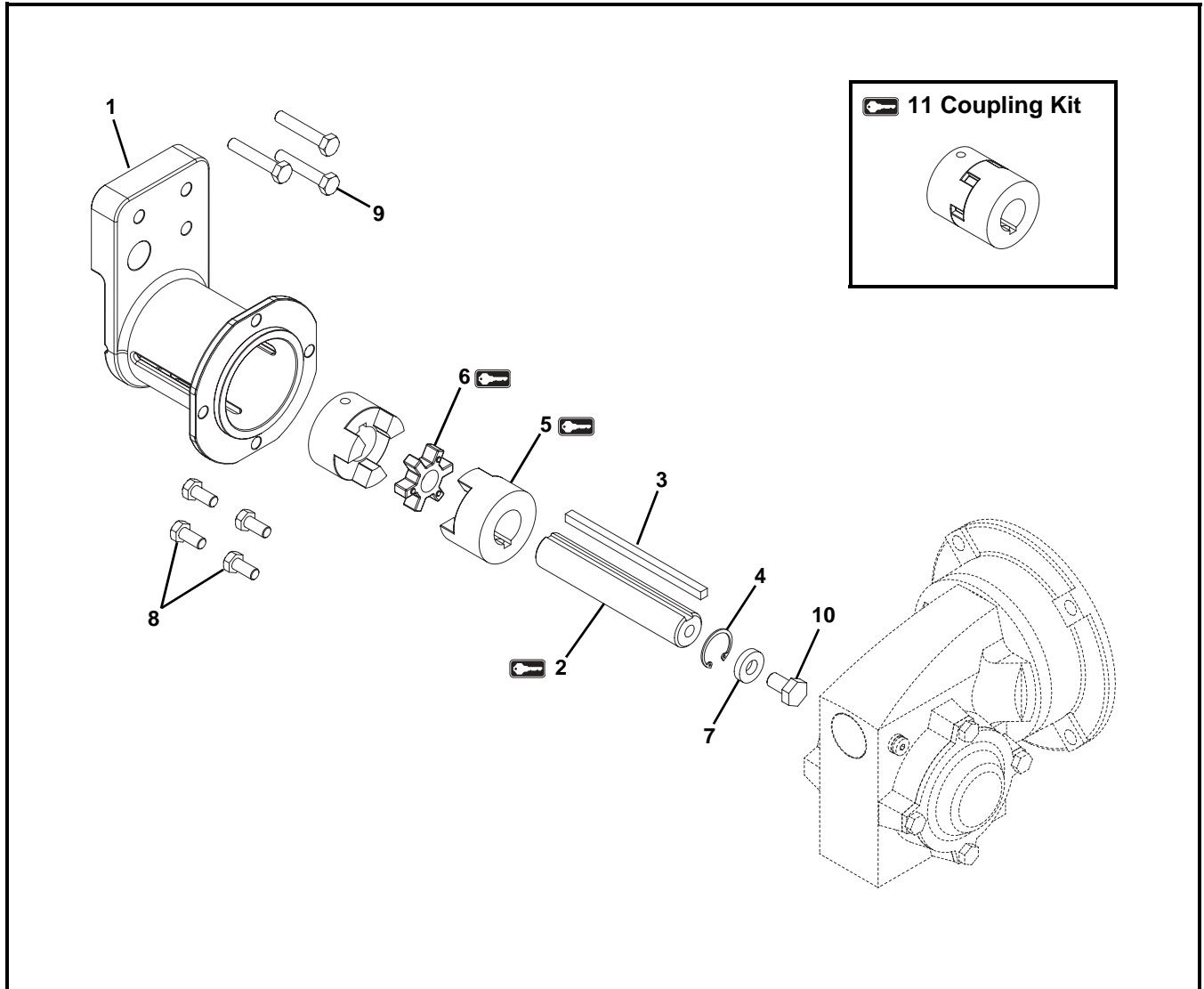



Item	Part Number	Description
1	520333	Motor Mount
2	516866	Shaft
	3	532121-00502 Square Key, .25" x 5.02"
4	807-3303	Retaining Ring
5	807-2281	3 Jaw Coupling
	6	807-3334 3 Jaw Rubber Spider
7	807-3392	Washer
8	960818MSS	Hex Head Cap Screw, M8-1.25 x 18 mm
9	960845MSS	Hex Head Cap Screw, M8-1.25 x 45 mm

Item	Part Number	Description
10	961018MSS	Hex Head Cap Screw, M10-1.50 x 18 mm
	11	807-3381 Coupling Kit (Includes items 5 and 6)
Service parts can be obtained through your distributor or directly from Dornier Mfg. Corp. (800) 397-8664 or customerservice@dornier.com		

Service Parts

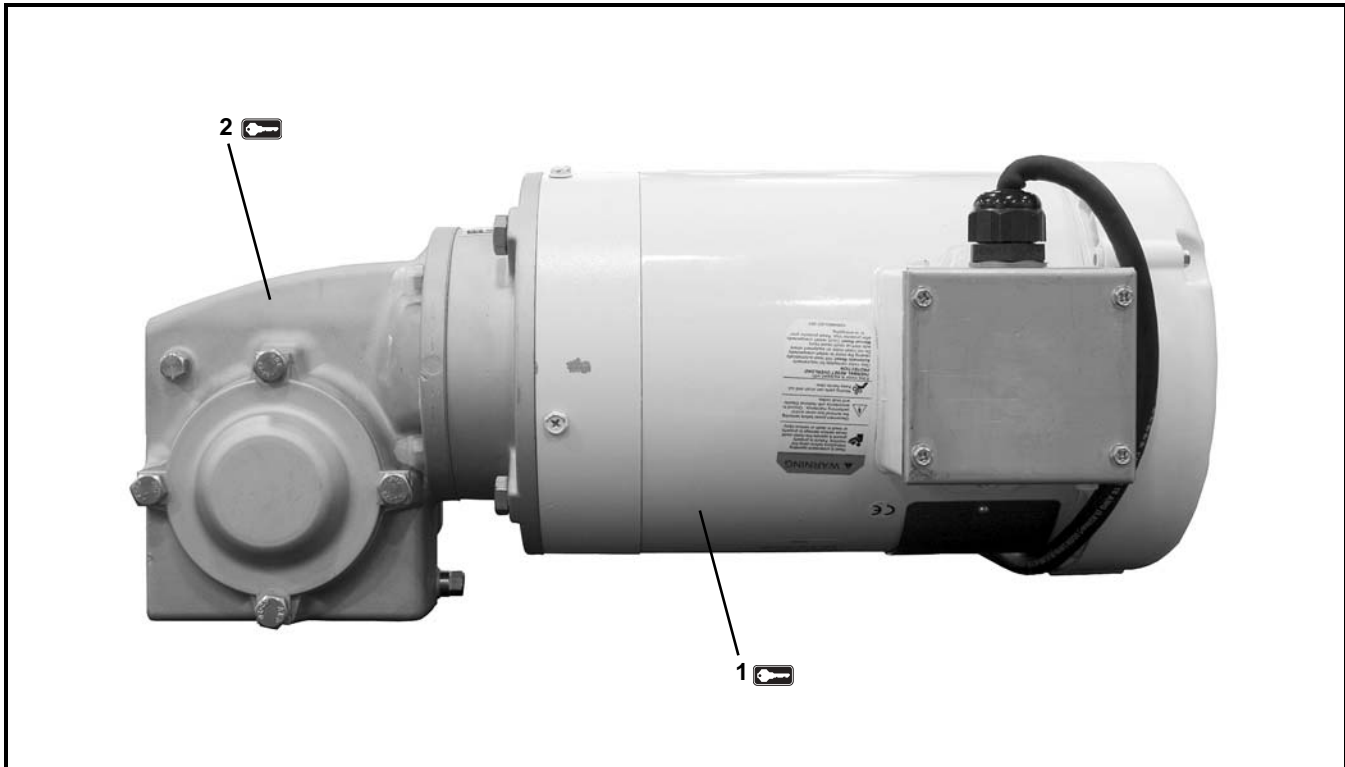
Gearmotor Assembly



Item	Part Number	Description
1 	826-312	Painted Motor, 0.5 hp, 230/460 volts, 60 Hz, 3 phase
	826-354	Painted Motor, 1.0 hp, 208-230/460 volts, 60 Hz, 3 phase
	826-472	Painted Motor, 1.5 hp, 208-230/460 volts, 60 Hz, 3 phase
	826-431	Stainless Steel Motor, 0.5 hp, 230/460 volts, 60 Hz, 3 phase
	826-466	Stainless Steel Motor, 1.0 hp, 208-230/460 volts, 60 Hz, 3 phase
	826-464	Stainless Steel Motor, 1.5 hp, 208-230/460 volts, 60 Hz, 3 phase
2 	820-735	Gear Reducer, 10:1, Nema 56C
	820-736	Gear Reducer, 15:1, Nema 56C
	820-737	Gear Reducer, 20:1, Nema 56C
	820-738	Gear Reducer, 30:1, Nema 56C
	820-739	Gear Reducer, 40:1, Nema 56C
	820-740	Gear Reducer, 60:1, Nema 56C

Return Policy

Returns must have prior written factory authorization or they will not be accepted. Items that are returned to Dorner without authorization will not be credited nor returned to the original sender. When calling for authorization, please have the following information ready for the Dorner factory representative or your local distributor:

1. Name and address of customer.
2. Dorner part number(s) of item(s) being returned.
3. Reason for return.
4. Customer's original order number used when ordering the item(s).
5. Dorner or distributor invoice number. Include part serial number if available.

A representative will discuss action to be taken on the returned items and provide a Returned Materials Authorization (RMA) number for reference. RMA will automatically close 30 days after being issued. To get credit, items must be new and undamaged. There will be a return charge on all items returned for credit, where Dorner was not at fault. It is the customer's responsibility to prevent damage during return shipping. Damaged or modified items will not be accepted. The customer is responsible for return freight.

Product Line	Product Type								Engineered to order parts
	Standard Products								
	Conveyors	Gearmotors & Mounting Packages	Support Stands	Accessories	Spare Parts (non-belt)	Spare Belts - Standard Flat Fabric	Spare Belts - Cleated & Spec. Fabric	Spare Belts - Plastic Chain	All equipment and parts
1100 Series	30% return fee for all products except: 50% return fee for conveyors with modular belt, cleated belt or speciality belts All Electrical items are assigned original manufacturers return policy.						non-returnable		case-by-case
2200 Series									
3200 Series									
Pallet Systems									
FlexMove/SmartFlex									
GAL Series									
All Electrical									
7100 Series	50% return fee for all products						non-returnable		case-by-case
7200/7300 Series									
AquaGard 7350 Series Version 2									
GES Series									
AquaGard 7350/7360 Series	non-returnable								
AquaPruf Series	non-returnable								

Returns will not be accepted after 60 days from original invoice date. The return charge covers inspection, cleaning, disassembly, disposal and reissuing of components to inventory. If a replacement is needed prior to evaluation of returned item, a purchase order must be issued. Credit (if any) is issued only after return and evaluation is complete.

Dorner has representatives throughout the world. Contact Dorner for the name of your local representative. Our Customer Service Team will gladly help with your questions on Dorner products.

For a copy of Dorner's Warranty, contact Dorner, an authorized sales channel or visit our website: www.dorner.com.

For replacement parts, contact an authorized Dorner Service Center or the factory.

www.dorner.com



© Dorner Mfg. Corp. 2018. All Rights Reserved.

Dorner – North & South America

Dorner – U.S.A.

Headquarters
 975 Cottonwood Ave
 Hartland, WI 53029, USA
 (800) 397-8664
 (262) 367-7600
info@dorner.com

Dorner – Canada

100-5515 North Service Road
 Burlington, Ontario L7L 6G6
 Canada
 (289) 208-7306
info@dorner.com

Dorner – Latin America

Carretera a Nogales #5297, Nave 11.
 Parque Industrial Nogales
 Zapopan, Jalisco C.P. 45222 México
 +52.33.30037400 | info.latinamerica@dorner.com

Dorner – Europe

Karl-Heinz-Beckurts-Straße 7
 52428 Jülich, Germany
 +49 (0) 2461/93767-0 | info.europe@dorner.com

Dorner – Asia

128 Jalan Permatang Damar Laut, Bayan Lepas 11960
 Penang, Malaysia
 +604-626-2948 | info.asia@dorner.com