

ENGINEERING MANUAL

Industry Leading
Hygienic Designs

Fast, Simple to Use
Online Configurator

Rapid Deliveries

3-A
Certified Conveyors

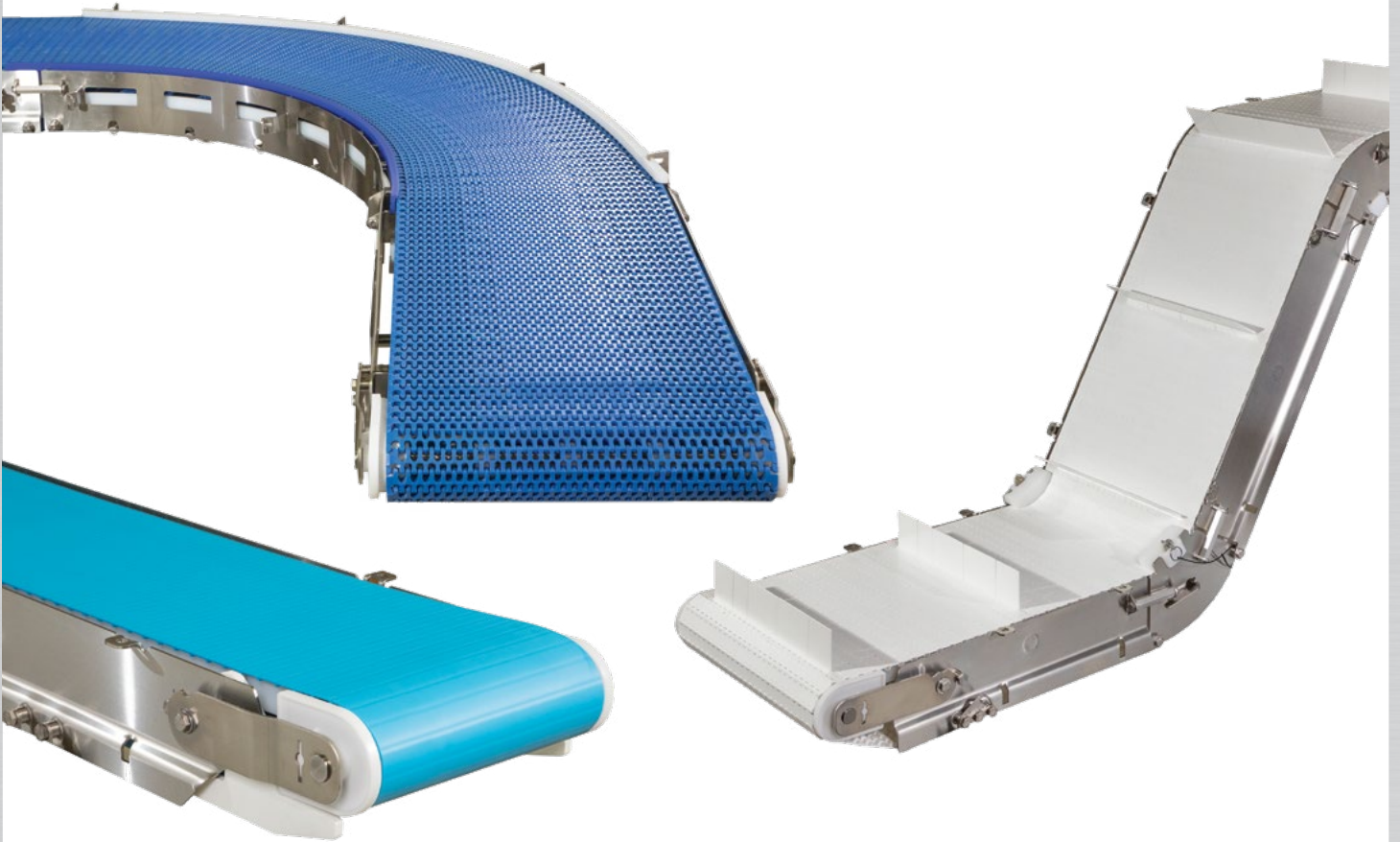

*Aqua***Pruf**[®]
.....

CONVEYORS

Improving Food Safety with
Hygienically Engineered Stainless Steel Conveyors

DORNER[®]

By Columbus McKinnon

Hygienic Design

- Tool-less disassembly. Cleaning prep in under a minute, complete disassembly in less than 3 minutes
- Optional frame cut-outs and belt lifters for continuous access to inside of the conveyor
- Tip-up tails allow for quick release of belt tension
- Continuous TIG-welded 304 stainless steel frame
- Spiral cam belt tensioning with patent pending threadless design
- Patented sprocket alignment key
- Gearless, oil-free iDrive2 sanitary motorized roller

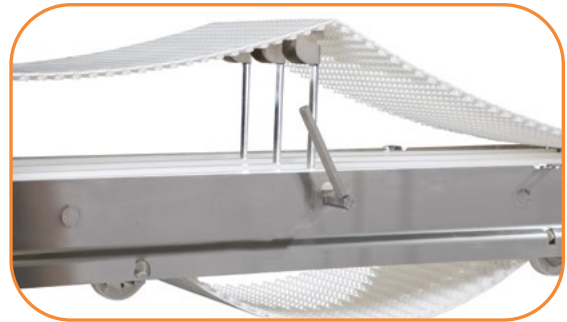

AquaPruf Ultimate

- Highest level of sanitation
- USDA red meat, poultry and dairy applications
- 3-A certified conveyors
- USDA and FDA approved belting and plastic components
- Meets 3-A and AMI design specifications
- #4 polish on all internal surfaces
- Patent pending drive sprocket wash-out channel
- Patent pending idler puck cleaning system

AquaPruf®
ULTIMATE



Engineered Solutions

- Dorner's Engineered Solutions Group can tailor fit AquaPruf Conveyors for specific applications and product handling requirements.
- With a custom-designed conveyor system in place, your products are processed faster, your services are delivered quicker, and your profits are increased with the help of highly specialized engineering.
- Solutions include:
 - Routing/Diverting/Laning/Merging
 - Singulating/Rotating
 - Accumulation/Buffering
 - Pacing/Gapping
 - Traffic Control/Flow
 - Orientating/Positioning
 - And More!



The Benefits of Dorner AquaPruf Conveyors

Industry Ready

- Designed and manufactured to food equipment standards
- 3-A certified conveyors
- FDA approved materials and components

Delivers Fast

- Dorner sets the industry standard for rapid delivery
- Sanitary conveyors ship in as little as 10 business days
- Industry leading cleaning preparation time

TABLE OF CONTENTS



FABRIC BELTS & POSITIVE DRIVE BELTS
PAGE 23-27

MODULAR BELT CONVEYORS PROFILES & GUIDING
PAGE 40-42

POSITIVE DRIVE CONVEYORS
PAGE 18-22

BELTED CONVEYORS PROFILES & GUIDING
PAGE 16-17

BELTED CONVEYORS
PAGE 6-15

MODULAR BELTS
PAGE 43-44

GEARMOTORS
PAGE 50-51

SUPPORT STANDS & ACCESSORIES
PAGE 53-56

MODULAR BELT CONVEYORS
PAGE 28-39

CONTROLS
PAGE 52

3-A CERTIFICATION
PAGE 45

BELT SPEED CHARTS
PAGE 49

GEARMOTOR MOUNTING PACKAGES
PAGE 48-49

ACCESSORIES
PAGE 57

 **TECHNICAL DATA & CALCULATIONS**
PAGE 58-74

From packaging to processing, Dörner has the food industry covered. By offering three series of sanitary conveyors – AquaGard, AquaPruf and AquaPruf Ultimate – Dörner can meet virtually any needs.

Sizes & Measurements

- 152 - 1524 mm (6 - 60 in) widths
- 914 - 25375 mm (36 - 999 in) lengths

Modular Belt Options

- Flat Modular Belt
- Friction Top
- Cleated
- Curve



Patented Sprocket Alignment Key



Flat Modular Belt

Loads & Speeds

- 98 kg per square meter (20 lbs per square foot)
- Speeds up to 100 mpm (328 fpm)

Belt Options

V-Guided and Positive Drive Belt Options

- Flat Belt
- Cleated
- Sidewall Cleated

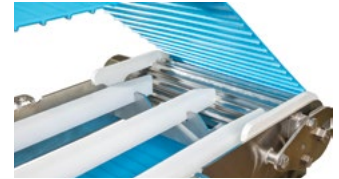

Positive Drive



Flat Belt

Configurations



Straights



Curves



LPZ (Z-Frames), Nose-Over & Horizontal to Inclines

Options



Nose Bar Transfers



Belt Lifters & Frame Cut-Outs



Belt Scrapers

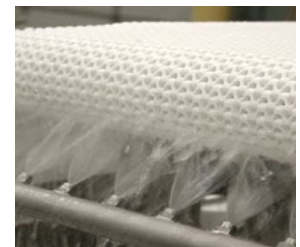

Clean-in-Place

Other options available including Chutes, Drip Pans, Guiding, Hoppers and more.

SANITARY CONVEYOR OVERVIEW



To identify the series best for you, simply locate your market and application in one of the charts below. You can then utilize the chart on the next page to select your specific conveyor model.

		Cleaning			Cleaning Agents				Environment		Sanitary Features				Regulations				Specifications		
		Wipe Down	Low Pressure Wash Down	High-Pressure Wash Down	Water	Soap/Water	Diluted Bleach or Alcohol	Foaming Caustic	Dry	Wet	Belt Lifters	Frame Cut-Outs	Tip-up Tail	3-A Sanitary Upgrades	Packaged Food	Dry Food	Ready to Eat	Meat, Poultry, Dairy	Belt Type	Frame Constructions	Configurations
AquaGard®	7100	X	X		X	X			X						X	X			Flexible Chain	Bolt Together Stainless Steel	Straight/ Curve/ Z-Frame
	7200	X	X		X	X	X		X						X	X			Belt	Low Profile Stainless Steel	Straight
	7300	X	X	X	X	X	X		X						X	X			Belt	Low Profile Stainless Steel	Straight
	7350	X	X		X	X	X		X	X		X			X	X			Modular Belt and Belt	Bolt Together Stainless Steel	Straight/ Curve/ Z-Frame
AquaPruf®	Modular Belt	X	X	X	X	X	X	X	X	X	X	X			X	X	X		Modular Belt	Continuous TIG Welded Stainless Steel	Straight/ Curve/ Z-Frame
	Belted	X	X	X	X	X	X	X	X	X	X	X			X	X	X		Belt	Continuous TIG Welded Stainless Steel	Straight/ Z-Frame
	Positive Drive Belt	X	X	X	X	X	X	X	X	X	X	X					X	X	Positive Drive Belt	Continuous TIG Welded Stainless Steel	Straight
	Ultimate	X	X	X	X	X	X	X	X	X	X	X	X				X	X	Belt, Positive Drive, Modular	Continuous TIG Welded Stainless Steel	Straight/ Curve/ Z-Frame
	VBT	X	X	X	X	X	X	X	X	X		X					X		Positive Drive Belt	Continuous TIG Welded Stainless Steel	Z-Frame



TOOL-LESS TIP-UP PULLEY
FOR QUICK RELEASE OF BELT TENSION

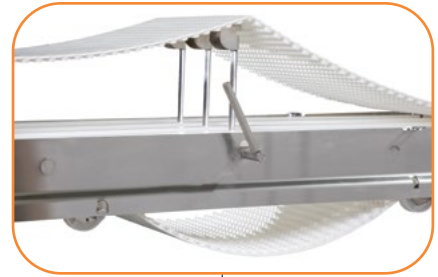

BELT LIFTERS
FOR EASE OF CLEANING ON LONG OR WIDE CONVEYORS



V-GUIDED BELTING
FOR POSITIVE BELT TRACKING



NOSE BAR TRANSFER OPTION
FOR SMALL PRODUCT TRANSFERS.
AVAILABLE IN: 12.7 MM (0.5 IN),
32 MM (1.25 IN) AND
48 MM (1.88 IN)



SPIRAL CAM TENSIONING
PATENT PENDING
THREADLESS TENSION
AND TRACKING METHOD



CAST ON URETHANE LAGGED PULLEY
ENSURES A PERMANENT SANITARY BOND



AquaPruf iDRIVE2 MOTORIZED ROLLER
NEW GEARLESS, OIL-FREE TECHNOLOGY PROVIDES
FOOD SAFE COMPACT FOOTPRINT

FULL RANGE OF SANITARY BELTING OPTIONS

SEALED EDGE, ENCASED AND
SOLID URETHANE FOR HYGENIC
PRODUCT MOVEMENTS



**STAINLESS STEEL
GEARMOTORS**
LOCATED OUTSIDE OF
FOOD ZONE



SOLID UHMW WEAR STRIPS
QUICKLY REMOVED WITHOUT TOOLS
FOR CLEANING. MOST PIECES
ARE IDENTICAL AND COMPLETELY
INTERCHANGEABLE.



CENTER DRIVE OPTION*
FOR DUAL NOSE BAR TRANSERS AND
INCREASED END CLEARANCE. TOOL-LESS
DISASSEMBLY FOR QUICK SANITATION



**STAINLESS STEEL WELDED
FRAME CONSTRUCTION**
ELIMINATES FASTENERS IN FOOD ZONE
(CONTINUOUS TIG WELDING)

*Patent Pending



Specifications

- Loads up to 227 kg (500 lbs) or 98 kg/sq m (20 lbs/sq ft)*
- Belt speeds up to 91 m/min (300 ft/min)
- Belt widths: 152 mm (6 in) to 1219 mm (48 in)
- Conveyor lengths: 915 mm (36 in) to 12190 mm (480 in)
- One revolution of drive pulley moves the belt approximately 280 mm (11 in)
- Continuous TIG Welded 304 Stainless Steel Frame
- 400 Series Stainless Steel bearing with FDA H1 food grade grease
- FDA approved belting and plastic components
- Open design with minimal horizontal surfaces
- Suitable for use in raw food applications
- Stainless Steel construction for wash down cleaning with caustic solutions
- V-Guide belt tracking



STANDARD FEATURE:
V-Guided Belt Tracking



STANDARD FEATURE:
Tip-Up Tail**



OPTIONAL:
Nose Bar Tail

12.7 mm (0.5 in),
32 mm (1.25 in) and
48 mm (1.88 in)

For nose bar max rated speeds, see pages 50-51



OPTIONAL:
Stainless Steel or UHMW Bedplates



OPTIONAL:
Belt Scraper

AquaPruf Flat Belt End Drive Conveyor

74 E M WWW - LLLL D I A 1 S S P P P B B - X T¹ T²

— Conveyor Tail Options X (if required) *See Drive Shaft Position Chart on next page

K = Keyed Auxiliary Shaft 0 = No Keyed Auxiliary Shaft

— Belt Type: See Pages 23-24 for belt selection

— Profile (D side)

— Profile (A side)

01 = Low Side 02 = 25 mm (1 in) Integral Stainless Steel High Side 04 = 75 mm (3 in) UHMW High Side
06 = 152 mm (6 in) UHMW High Side 13 = Fully Adjustable Round 14 = Tool-less Fully Adjustable Round
23 = 75mm (3 in) Tall Stainless Steel High Side 26 = 152mm (6 in) Tall Stainless Steel High Side

— Idler Stand Location:

A = No Stand Mount Mounting brackets B = 300 mm (11.8 in) from end C = 450 mm (17.7 in) from end D = 600 mm (23.6 in) from end
E = 750 mm (29.5 in) from end F = 900 mm (35.4 in) from end G = 300 mm (11.8 in) from end with braces H = 450 mm (17.7 in) from end with braces
J = 600 mm (23.6 in) from end with braces K = 750 mm (29.5 in) from end with braces M = 900 mm (35.4 in) from end with braces

— Drive Stand Location:

A = No Stand Mount Mounting brackets B = 300 mm (11.8 in) from end C = 450 mm (17.7 in) from end D = 600 mm (23.6 in) from end
G = 300 mm (11.8 in) from end with braces H = 450 mm (17.7 in) from end with braces J = 600 mm (23.6 in) from end with braces

— Cleaning Option/Scraper: 0 = None 1 = Frame Cut Outs only 2 = Belt Lifters only 3 = Frame Cut Out and Belt Lifters 4 = Scraper only

5 = Frame Cut Outs and Scraper 6 = Belt Lifters and Scraper 7 = Frame Cut Out, Belt Lifters, and Scraper

— Drive Shaft Position: A, B, C or D

— Idler Tail Type/V-Guide: 1 = Standard without V-Guide 2 = 12.7 mm (0.5 in) Nose Bar without V-Guide 3 = 32 mm (1.25 in) Nose Bar without V-Guide

4 = 48 mm (1.875 in) Nose Bar without V-Guide 5 = Standard with V-Guide 7 = 32 mm (1.25 in) Nose Bar with V-Guide 8 = 48 mm (1.875 in) Nose Bar with V-Guide

— Drive Tail Type/Bedplate: 1 = Customer supplied motor with UHMW bed 2 = Customer supplied motor with Stainless bed 3 = Motorized roller with UHMW bed

4 = Motorized roller with Stainless bed 5 = Side drive with UHMW bed 6 = Side drive with Stainless bed

— Conveyor Length (mm): 00915 to 12190 in 5 mm increments (36 - 480 in)

— Conveyor Width Reference (mm): = 152 to 1219 (6 - 48 in)

— Documentation Language: M = US English

* Conveyor load capacity depends on conveyor size, incline, motor position, accumulated loads and other factors. ** Note: Do not run the conveyor with the tail in the tip-up position.

Order gearmotor mounting packages and gearmotors separately, see pages 48-51.

For support stands and accessories, see page 53-56.

FLAT BELT END DRIVE



SANITARY OPTIONS



NOSEBAR



FRAME CUTOUTS



iDRIVE 2

MOTORIZED ROLLER



BELT LIFTER

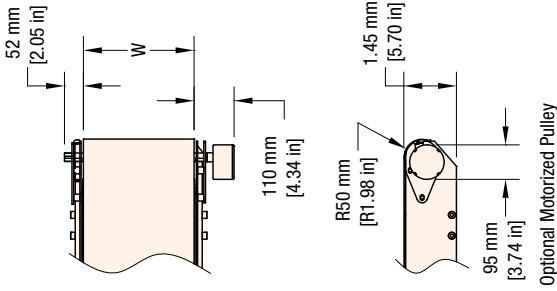

See page 22 for side profile options

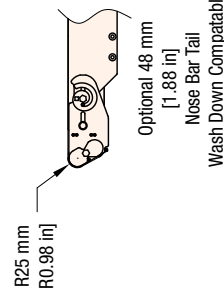
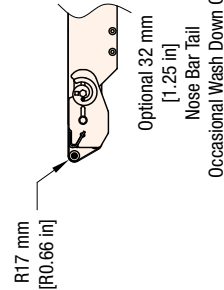
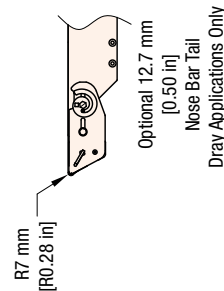
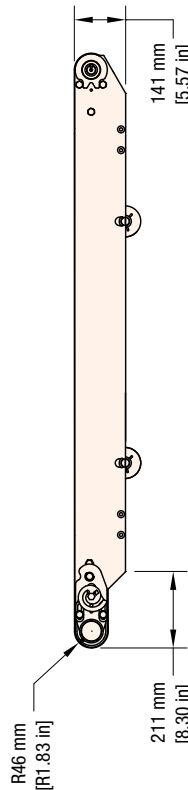
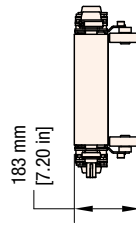
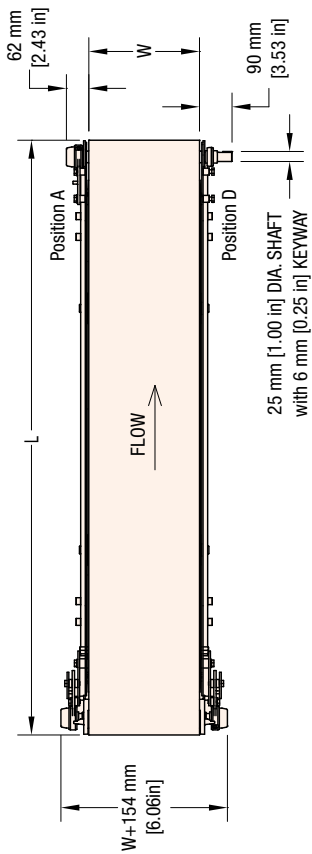

W = Conveyor Belt Width Dim = mm (in)

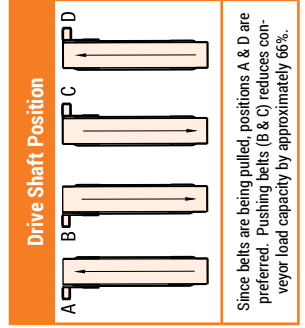

Since belts are being pulled, positions A & D are preferred. Pushing belts (B & C) reduces conveyor load capacity by approximately 66%.

STANDARD SIZES						
Conveyor Width Reference	152	203	254	1118	1168	1219
Conveyor Belt Width (W)	152	203	254	1118	1168	1219
	(6)	(8)	(10)	(44)	(46)	(48)
Conveyor Length Reference	00915			12190		
Conveyor Length (L)	00915 (36)			12190 (480)		

Due to the wide variety of drive set ups and applications, point of installation guarding is the responsibility of the end user.



Specifications

- Loads up to 227 kg (500 lbs) or 98 kg/sq m (20 lbs/sq ft)*
- Belt speeds up to 91 m/min (300 ft/min)
- Belt widths: 152 mm (6 in) to 1219 mm (48 in)
- Conveyor lengths: 915 mm (36 in) to 12190 mm (480 in)
- One revolution of drive pulley moves the belt approximately 280 mm (11 in)
- Continuous TIG Welded 304 Stainless Steel Frame
- 400 Series Stainless Steel bearing with FDA H1 food grade grease
- FDA approved belting and plastic components
- Open design with minimal horizontal surfaces
- Suitable for use in raw food applications
- Stainless Steel construction for wash down cleaning with caustic solutions
- V-Guide belt tracking



STANDARD FEATURE:
V-Guided Belt Tracking



STANDARD FEATURE:
Tip-Up Tail**



OPTIONAL:
Nose Bar Tail
12.7 mm (0.5 in),
32 mm (1.25 in) and
48 mm (1.88 in)

For nose bar max rated speeds, see pages 50-51



OPTIONAL:
Stainless Steel or UHMW Bedplates



OPTIONAL:
Belt Scraper

AquaPruf Flat Belt Center Drive Conveyor

74	M	M	WWW	-	LLLLL	D	I	A	1	S	S	P	P	P	B	B	-	X	T ¹	T ²
																			<p>Conveyor Tail Options X (if required) *See Drive Shaft Position Chart on next page K = Keyed Auxiliary Shaft 0 = No Keyed Auxiliary Shaft</p>	
																			<p>Belt Type: See Pages 23-24 for belt selection</p>	
																			<p>Profile (D side)</p>	
																			<p>Profile (A side)</p>	
																			<p>01 = Low Side 02 = 25 mm (1 in) Integral Stainless Steel High Side 04 = 75 mm (3 in) UHMW High Side 06 = 152 mm (6 in) UHMW High Side 13 = Fully Adjustable Round 14 = Tool-less Fully Adjustable Round 23 = 75mm (3 in) Tall Stainless Steel High Side 26 = 152mm (6 in) Tall Stainless Steel High Side</p>	
																			<p>Idle Stand Location:</p>	
																			<p>A = No Stand Mount Mounting brackets B = 300 mm (11.8 in) from end C = 450 mm (17.7 in) from end D = 600 mm (23.6 in) from end E = 750 mm (29.5 in) from end F = 900 mm (35.4 in) from end G = 300 mm (11.8 in) from end with braces H = 450 mm (17.7 in) from end with braces J = 600 mm (23.6 in) from end with braces K = 750 mm (29.5 in) from end with braces M = 900 mm (35.4 in) from end with braces</p>	
																			<p>Drive Stand Location:</p>	
																			<p>A = No Stand Mount Mounting brackets B = 300 mm (11.8 in) from end C = 450 mm (17.7 in) from end D = 600 mm (23.6 in) from end E = 750 mm (29.5 in) from end F = 900 mm (35.4 in) from end G = 300 mm (11.8 in) from end with braces H = 450 mm (17.7 in) from end with braces J = 600 mm (23.6 in) from end with braces K = 750 mm (29.5 in) from end with braces M = 900 mm (35.4 in) from end with braces</p>	
																			<p>Cleaning Option/Scraper: 0 = None 1 = Frame Cut Outs only 2 = Belt Lifters only 3 = Frame Cut Out and Belt Lifters 4 = Scraper only 5 = Frame Cut Outs and Scraper 6 = Belt Lifters and Scraper 7 = Frame Cut Out, Belt Lifters, and Scraper</p>	
																			<p>Drive Shaft Position: A or D</p>	
																			<p>Infeed Tail Type/V-guide: 1 = Standard without V-Guide 2 = 12.7 mm (0.5 in) Nose Bar without V-Guide 3 = 32 mm (1.25 in) Nose Bar without V-Guide 4 = 48 mm (1.875 in) Nose Bar without V-Guide 5 = Standard with V-Guide 7 = 32 mm (1.25 in) Nose Bar with V-Guide 8 = 48 mm (1.875 in) Nose Bar with V-Guide</p>	
																			<p>Exit Tail Type/Bedplate: 0 = Standard Fixed with UHMW Bed 1 = 12.7 mm (0.5 in) Nose Bar Tip Up with UHMW Bed 2 = 32 mm (1.25 in) Nose Bar Tip Up with UHMW Bed 3 = 48 mm (1.875 in) Nose Bar Tip Up with UHMW Bed 4 = Standard Fixed with SS Bed 5 = 12.7 mm (0.5 in) Nose Bar Tip Up with SS Bed 6 = 32 mm (1.25 in) Nose Bar Tip Up with SS Bed 7 = 48 mm (1.875 in) Nose Bar Tip Up with SS Bed</p>	
																			<p>Conveyor Length (mm): 00915 to 12190 in 5 mm increments (36 - 480 in)</p>	
																			<p>Conveyor Width Reference (mm): = 0152 to 1219 (6 - 48 in)</p>	
																			<p>Documentation Language: M = US English</p>	

* Conveyor load capacity depends on conveyor size, incline, motor position, accumulated loads and other factors. ** Note: Do not run the conveyor with the tail in the tip-up position.

Order gearmotor mounting packages and gearmotors separately, see pages 48-51.
 For support stands and accessories, see page 53-56.

FLAT BELT CENTER DRIVE

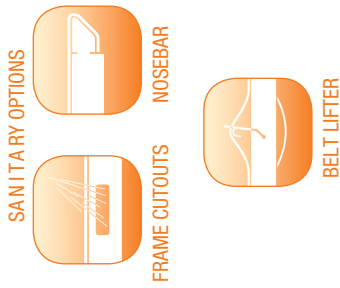

See page 22 for side profile options

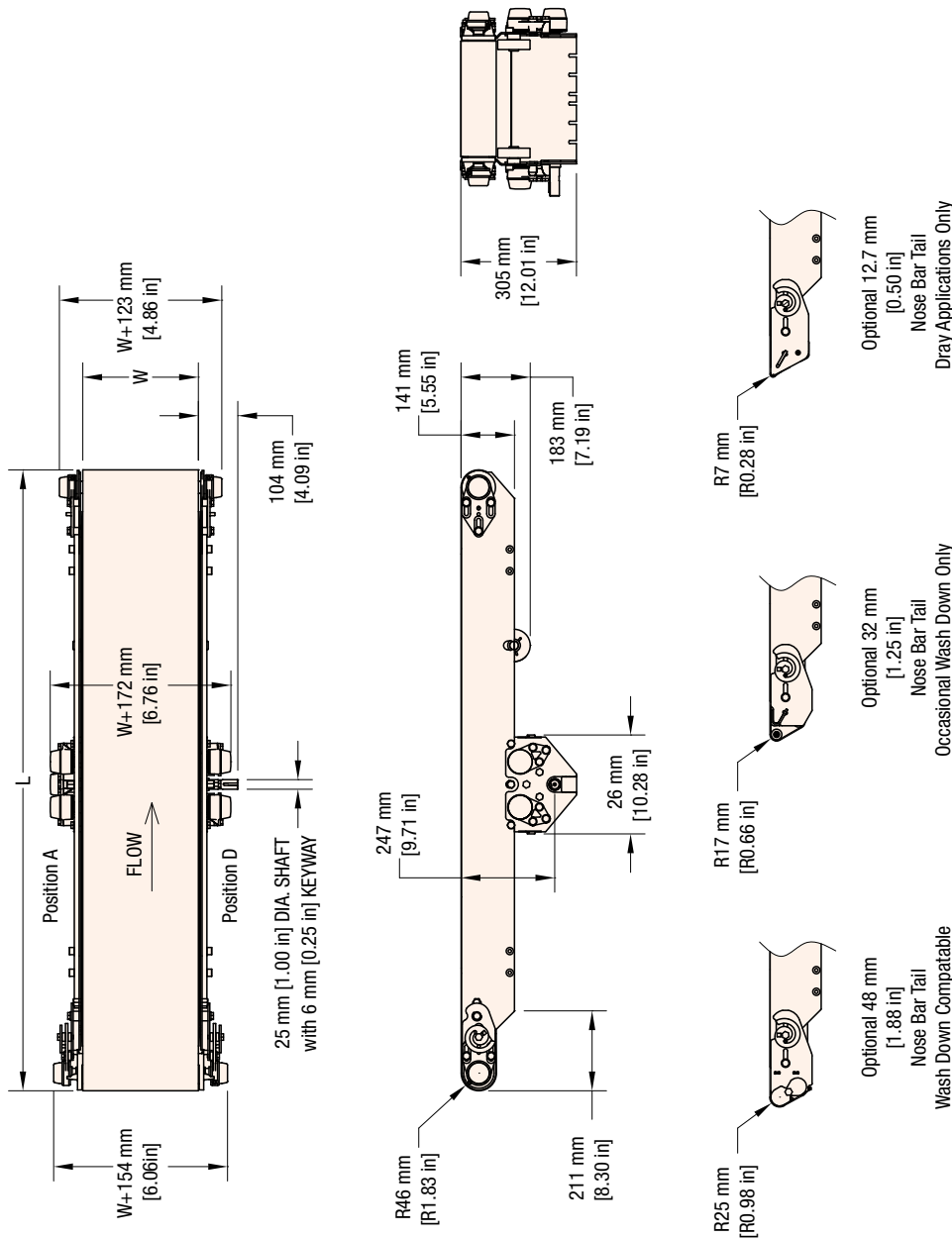

W = Conveyor Belt Width Dim = mm (in)

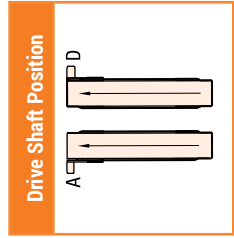

STANDARD SIZES						
Conveyor Width Reference	152	203	254	1118	1168	1219
Conveyor Belt Width (W)	152	203	254	1118	1168	1219
	(6)	(8)	(10)	(44)	(46)	(48)
Conveyor Length Reference	00915			12190		
Conveyor Length (L)	00915 (36)			12190 (480)		
				50 increments up to...		
				50 mm increments up to...		
				2 in increments up to...		
				00005 increments up to...		
				00005 (0.2) increments up to...		

Due to the wide variety of drive set ups and applications, point of installation guarding is the responsibility of the end user.

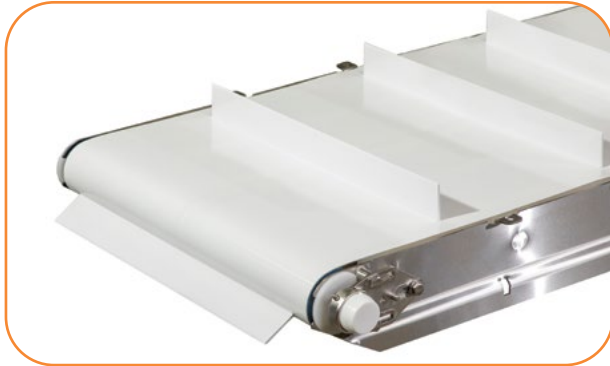

Specifications

- Loads up to 227 kg (500 lbs) or 98 kg/sq m (20 lbs/sq ft)*
- Belt speeds up to 91 m/min (300 ft/min)
- Belt widths: 203 mm (8 in) to 610 mm (24 in)
- Conveyor lengths: 915 mm (36 in) to 6095 mm (240 in)
- Cleat heights from 11 mm (0.43 in) to 60 mm (2.63 in)
- Continuous TIG Welded 304 Stainless Steel Frame
- 400 Series Stainless Steel bearing with FDA H1 food grade grease
- FDA approved belting and plastic components
- Cleated belt options include sealed edge, encased and sidewall cleating
- Open design with minimal horizontal surfaces
- Suitable for use in raw food applications
- Stainless Steel construction for wash down cleaning with caustic solutions
- V-Guide belt tracking



STANDARD FEATURE:
V-Guided Belt Tracking



STANDARD FEATURE:
Tip-Up Tail**



OPTIONAL:
High Side Guides
Up to 152 mm
(6 in) Tall



OPTIONAL:
Stainless Steel or
UHMW Bedplates

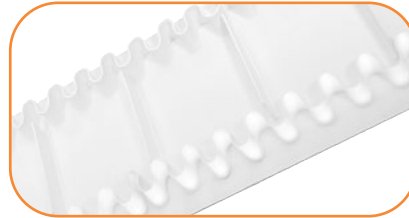

OPTIONAL:
Sidewall Cleated
Belts for Bulk
Food Product

AquaPruf Cleated Belt End Drive Conveyor

74 C M WWW - L L L L L D I A T S S P C S S S S - X T¹ T²

— Conveyor Tail Options X (if required) *See Drive Shaft Position Chart on next page

K = Keyed Auxiliary Shaft Ø = No Keyed Auxiliary Shaft

— Spacing: SSSS in millimeters

— Belt Type: See Pages 23-26 for belt selection

— Profile

1 = Low Side 4 = 75 mm (3 in) UHMW High Side 6 = 152 mm (6 in) UHMW High Side

7 = 75 mm (3 in) Tall Stainless Steel High Side 8 = 152 mm (6 in) Tall Stainless Steel High Side

— Idler Stand Location:

A = No Stand Mount Mounting brackets B = 300 mm (11.8 in) from end C = 450 mm (17.7 in) from end D = 600 mm (23.6 in) from end

E = 750 mm (29.5 in) from end F = 900 mm (35.4 in) from end G = 300 mm (11.8 in) from end with braces H = 450 mm (17.7 in) from end with braces

J = 600 mm (23.6 in) from end with braces K = 750 mm (29.5 in) from end with braces M = 900 mm (35.4 in) from end with braces

— Drive Stand Location:

A = No Stand Mount Mounting brackets B = 300 mm (11.8 in) from end C = 450 mm (17.7 in) from end D = 600 mm (23.6 in) from end

G = 300 mm (11.8 in) from end with braces H = 450 mm (17.7 in) from end with braces J = 600 mm (23.6 in) from end with braces

— Cleaning Option/Scraper: 0 = None 1 = Frame Cut Outs only 2 = Belt Lifters only 3 = Frame Cut Out and Belt Lifters

— Drive Shaft Position: A, B, C or D

— Infeed Tail Type/V-guide: 1 = Standard without V-Guide 5 = Standard with V-Guide

— Drive Tail Type/Bedplate: 1 = Customer supplied motor with UHMW bed 2 = Customer supplied motor with Stainless bed 3 = Motorized roller with UHMW bed

4 = Motorized roller with Stainless bed 5 = Side drive with UHMW bed 6 = Side drive with Stainless bed

— Conveyor Length (mm): 00915 to 06095 in 5 mm increments (36 - 240 in)

— Conveyor Width Reference (mm): = 0203 to 0610 (8 - 24 in)

— Documentation Language: M = US English

* Conveyor load capacity depends on conveyor size, incline, motor position, accumulated loads and other factors. ** Note: Do not run the conveyor with the tail in the tip-up position.

Order gearmotor mounting packages and gearmotors separately, see pages 48-51.
For support stands and accessories, see page 53-56.

CLEATED BELT END DRIVE

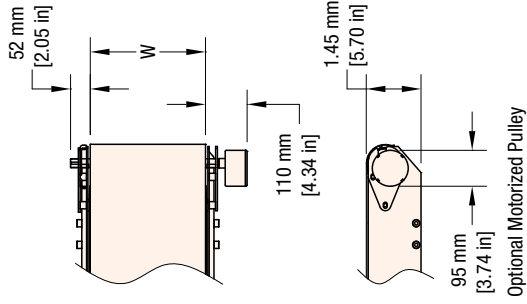
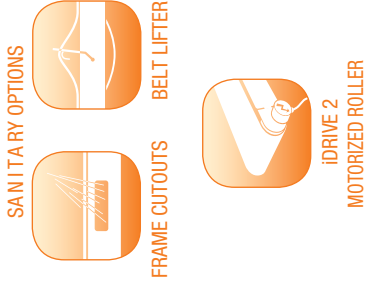

Optional Motorized Pulley

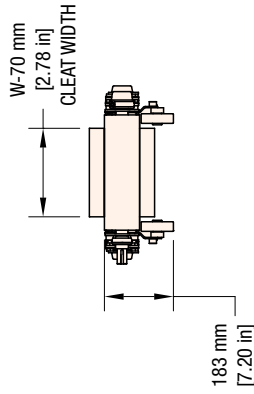

See page 22 for side profile options

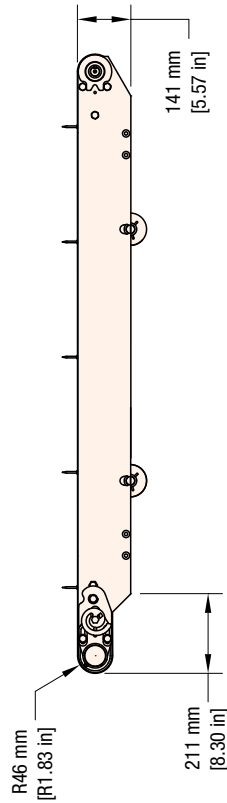
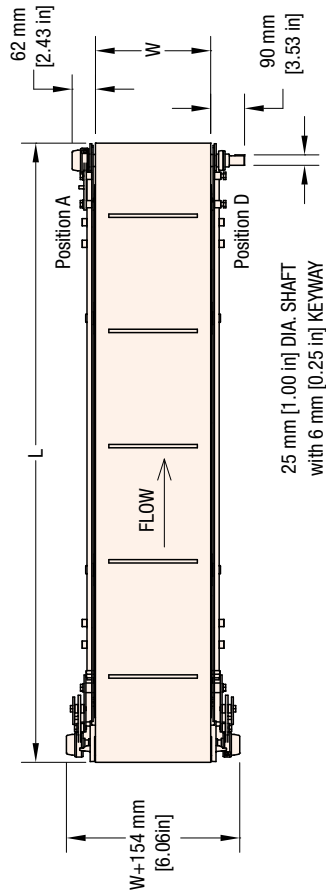

W = Conveyor Belt Width Dim = mm (in)

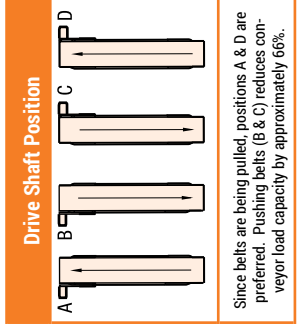

Since belts are being pulled, positions A & D are preferred. Pushing belts (B & C) reduces conveyor load capacity by approximately 66%.

STANDARD SIZES											
Conveyor Width Reference	152	203	254	305	356	406	457	508	559	610	
Conveyor Belt Width (W)	152	203	254	305	356	406	457	508	559	610	
	(6)	(8)	(10)	(12)	(14)	(16)	(18)	(20)	(22)	(24)	
Conveyor Length Reference	00915		00005 increments up to...								6095
Conveyor Length (L)	0915 (36)		00005 (0.2) increments up to...								6095 (240)

Note: If conveyor width ≥ 457 then the max length is 2135

Due to the wide variety of drive set ups and applications, point of installation guarding is the responsibility of the end user.

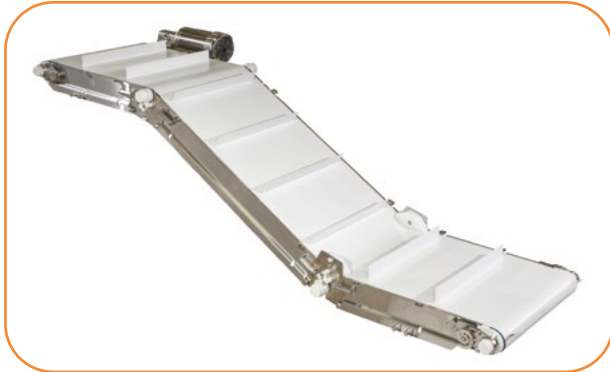

Specifications

- Loads up to 45 kg (100 lbs) or 98 kg/sq m (20 lbs/sq ft)*
- Belt speeds up to 91 m/min (300 ft/min)
- Belt widths: 203 mm (8 in) to 610 mm (24 in)
- Conveyor section lengths: 610 mm (24 in) to 6100 mm (240 in)
- Maximum total conveyor length of 12190 mm (480 in)
- Angles from 30 degrees to 60 degrees in 5 degree increments
- Cleat heights from 11 mm (0.43 in) to 60 mm (2.63 in)
- Continuous TIG Welded 304 Stainless Steel Frame
- FDA approved belting and plastic components
- Cleated belt options include sealed edge, encased and sidewall cleating
- Open design with minimal horizontal surfaces
- Suitable for use in raw food applications
- Stainless Steel construction for wash down cleaning with caustic solutions
- V-Guide belt tracking

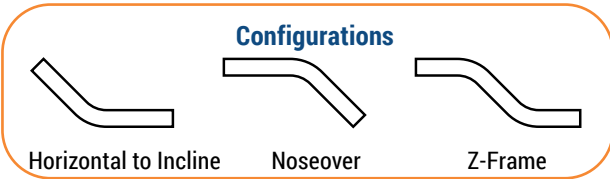

STANDARD FEATURE:
V-Guided Belt Tracking



OPTIONAL:
High Side Guides



STANDARD FEATURE:
Tip-Up Tail**

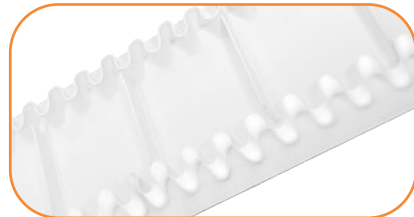

OPTIONAL:
Sidewall Cleated Belts for Bulk Food Product

AquaPruf Z-Frame Cleated Belt End Drive Conveyor

74	C	M	WWW	-	LLLLL	-	LLLLL	-	LLLLL	AA	E	D	I	A	1	S	S	P	C	SSSS	-	X	T ¹
																						- Conveyor Tail Options X (if required) *See Drive Shaft Position Chart on next page	
																						K = Keyed Auxiliary Shaft Ø = No Keyed Auxiliary Shaft	
																						- Spacing: SSSS in millimeters	
																						- Belt/Cleat Type: See Pages 23-26 for belt selection	
																						- Profile: 1 = Low Side	
																						7 = 75 mm (3 in) Tall Stainless Steel High Side 8 = 152mm (6 in) Tall Stainless Steel High Side	
																						- Idler Stand Location:	
																						A = No Stand Mount Mounting brackets B = 300 mm (11.8 in) from end C = 450 mm (17.7 in) from end	
																						D = 600 mm (23.6 in) from end E = 750 mm (29.5 in) from end F = 900 mm (35.4 in) from end	
																						- Drive Stand Location:	
																						A = No Stand Mount Mounting brackets B = 300 mm (11.8 in) from end C = 450 mm (17.7 in) from end	
																						D = 600 mm (23.6 in) from end E = 750 mm (29.5 in) from end F = 900 mm (35.4 in) from end	
																						- Cleaning Option/Scraper: 0 = None 1 = Frame Cut Outs only 2 = Belt Lifters only 3 = Frame Cut Out and Belt Lifters	
																						- Drive Shaft Position: A, B, C, or D	
																						- Infeed Tail Type/V-guide: 1 = Standard without V-Guide 5 = Standard with V-Guide	
																						- Drive Tail Type/Bedplate: 1 = Customer supplied motor with UHMW bed 3 = Motorized roller with UHMW bed 5 = Side drive with UHMW bed	
																						- Belt Direction: E = Inclining, D = Declining	
																						- Angle: 30 degrees thru 60 degrees in 05 degree increments	
																						- Conveyor L3 Lower Horizontal Section Length (mm): 00610 - 06100 (24 - 240 in) 5 mm increments	
																						- Conveyor L2 Angled Section Length (mm): 00610 - 06100 (24 - 240 in) 5 mm increments	
																						- Conveyor L1 Upper Horizontal Section Length (mm): 00610 - 06100 (24 - 240 in) 5 mm increments	
																						- Conveyor Width Reference (mm): = 0203 to 0610 (8 - 24 in)	
																						- Documentation Language: M = US English	

* Conveyor load capacity depends on conveyor size, incline, motor position, accumulated loads and other factors. ** Note: Do not run the conveyor with the tail in the tip-up position.

Order gearmotor mounting packages and gearmotors separately, see pages 48-51.
For support stands and accessories, see page 53-56.

LPZ (Z-FRAME) CLEATED BELT END DRIVE



See page 22 for side profile options

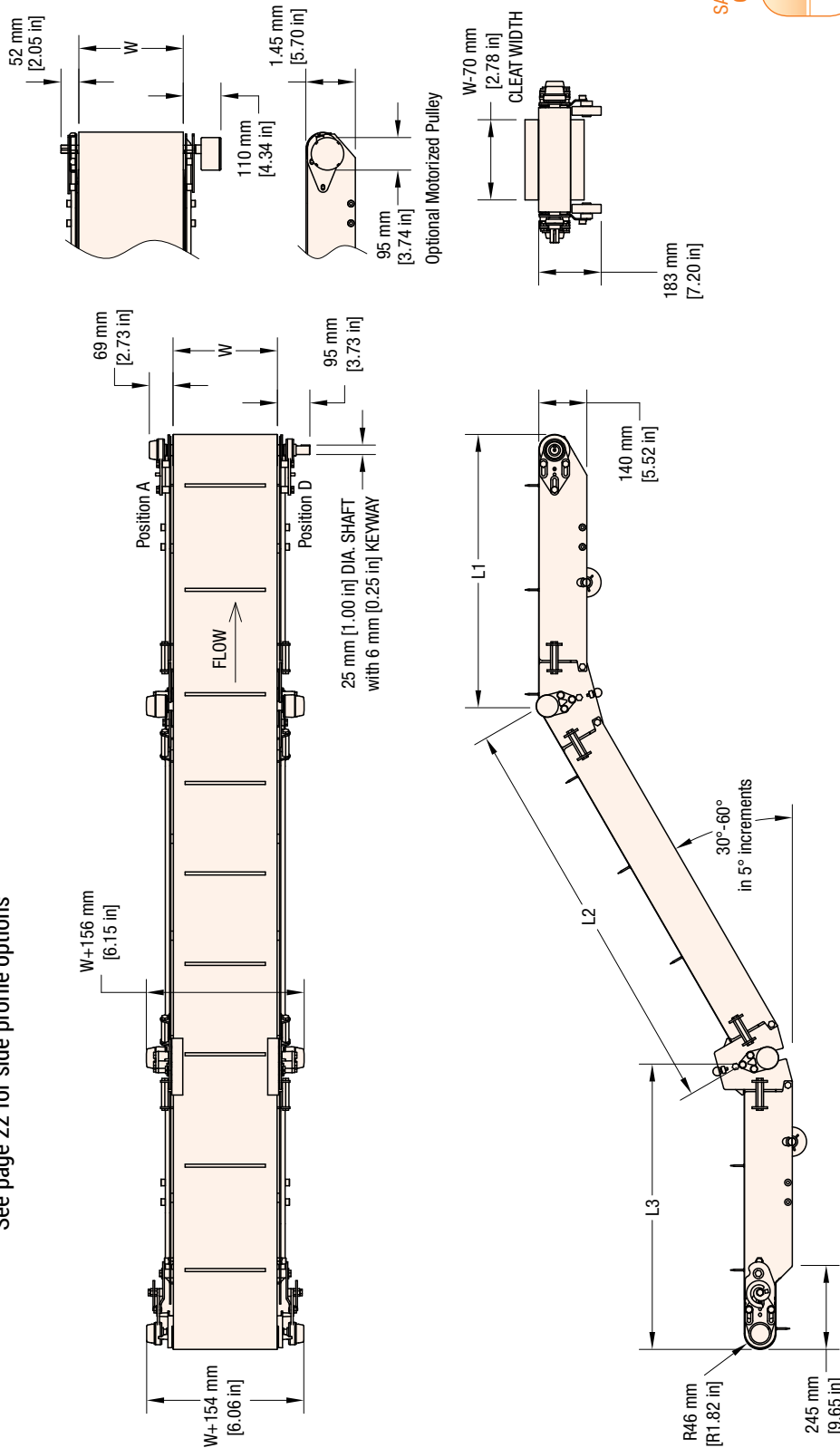

SANITARY OPTIONS



FRAME CUTOUPS



BELT LIFTER



iDRIVE 2
MOTORIZED ROLLER

Drive Shaft Position

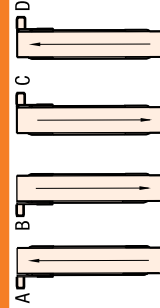

Since belts are being pulled, positions A & D are preferred. Pushing belts (B & C) reduces conveyor load capacity by approximately 66%.

W = Conveyor Belt Width Dim = mm (in)

STANDARD SIZES										
Conveyor Width Reference	152	203	254	305	356	406	457	508	559	610
Conveyor Belt Width (W)	152	203	254	305	356	406	457	508	559	610
	(6)	(8)	(10)	(12)	(14)	(16)	(18)	(20)	(22)	(24)
Conveyor Length Reference	0610 increments up to...									
Conveyor Length (L1/L2/L3)	0610	00005 (0.2) increments up to...								
	0610 (24)	6100 (240)								

Note: If conveyor width ≥ 457 mm then the max length is 2135 mm.
Max total length of all sections 12190 mm (480 in).

Due to the wide variety of drive set ups and applications, point of installation guarding is the responsibility of the end user.

FLAT BELT PROFILES

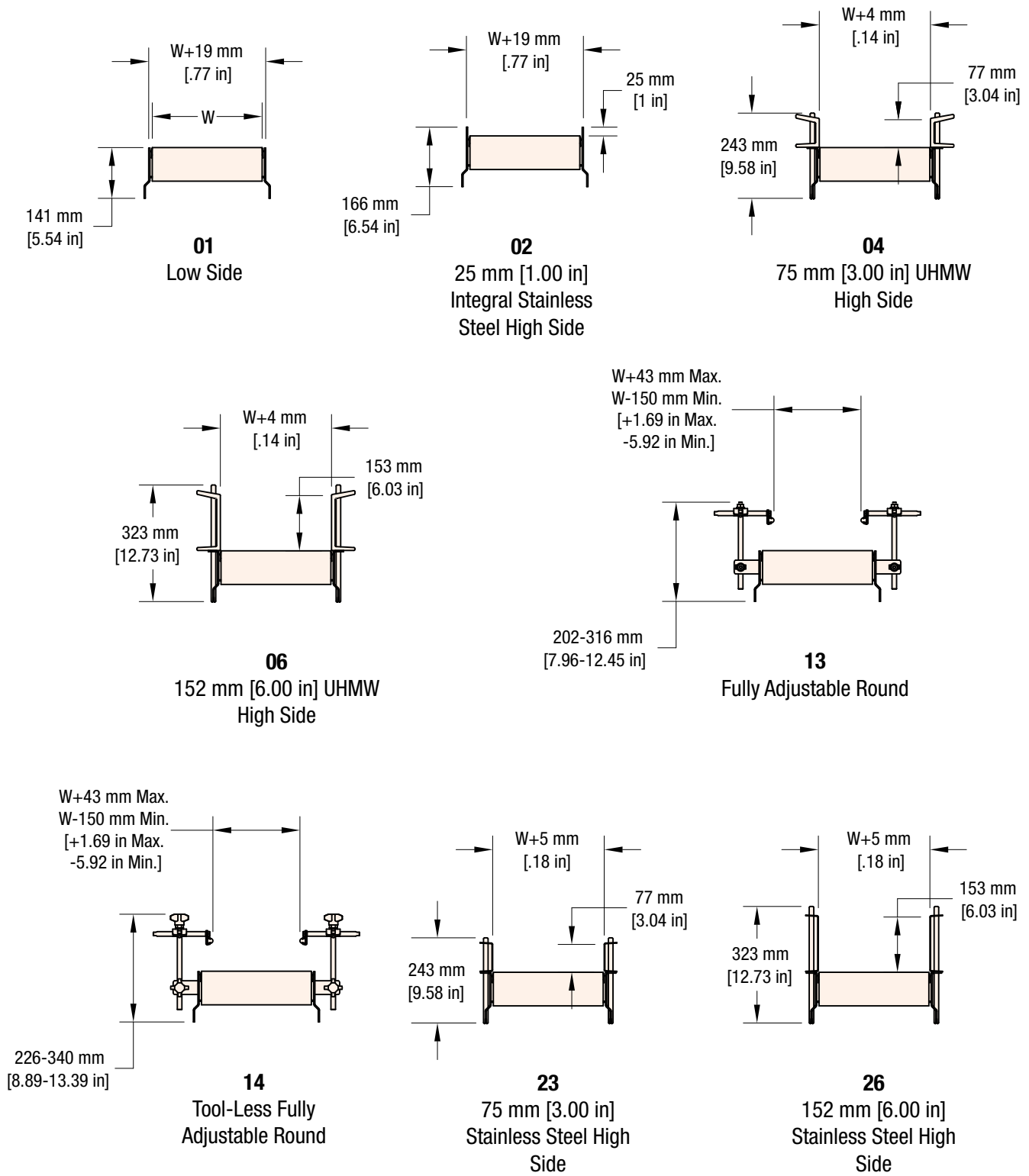

CLEATED BELT PROFILES

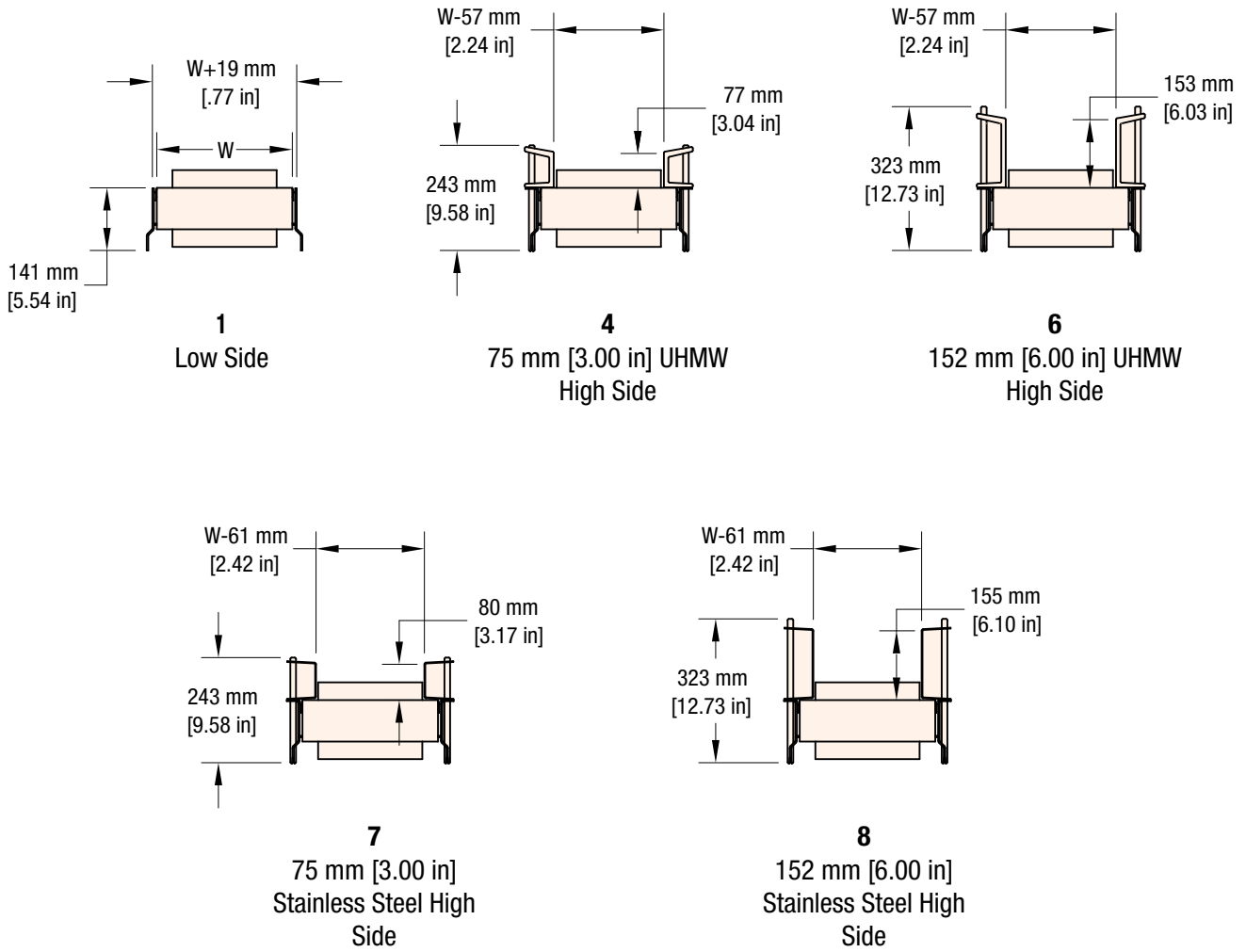

All AquaPruf stainless steel and UHMW guiding profiles are quick removal without tools for fast effective cleaning

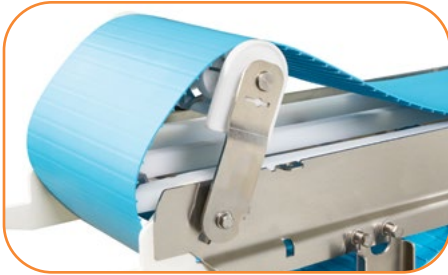

TOOL-LESS TIP-UP PULLEY
FOR QUICK RELEASE OF BELT TENSION

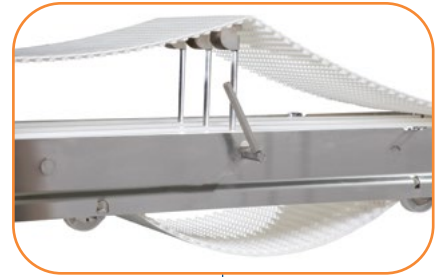

BELT LIFTERS
FOR EASE OF CLEANING ON LONG OR WIDE CONVEYORS

POSITIVELY DRIVER SOLID URETHANE BELTING
FDA AND USDA APPROVED FOR THE MOST DEMANDING APPLICATIONS



QUICK REMOVAL SIDE MOUNT GEARMOTOR
TO REDUCE SANITATION TIME



SPROCKET DRIVEN
TO AVOID SLIPPING IN WET ENVIRONMENTS

*Note: Do not run the conveyor with the tail in the tip-up position.



AquaPruf iDRIVE2 MOTORIZED ROLLER
NEW GEARLESS, OIL-FREE TECHNOLOGY PROVIDES
FOOD SAFE COMPACT FOOTPRINT



**STAINLESS STEEL
GEARMOTORS**
LOCATED OUTSIDE OF FOOD
ZONE



SOLID UHMW WEAR STRIPS
QUICKLY REMOVED WITHOUT TOOLS
FOR CLEANING. MOST PIECES
ARE IDENTICAL AND COMPLETELY
INTERCHANGEABLE. FOR COMPLETE
DRAINAGE.



**STAINLESS STEEL WELDED
FRAME CONSTRUCTION**
ELIMINATES FASTENERS IN FOOD ZONE
(CONTINUOUS TIG WELDING)





Specifications

- Loads up to 227 kg (500 lbs) or 98 kg/sq m (20 lbs/sq ft)*
- Belt speeds up to 91 m/min (300 ft/min)
- Belt widths: 203 mm (8 in) to 1219 mm (48 in)
- Conveyor lengths: 915 mm (36 in) to 12190 mm (480 in)
- Positive driven belt provides greater load capacity and less slip
- Continuous TIG Welded 304 Stainless Steel Frame
- 400 Series Stainless Steel bearing with FDA H1 food grade grease
- USDA smooth top positive drive belt (Available in blue or white)
- Open design with minimal horizontal surfaces
- Suitable for use in raw food applications
- Stainless Steel construction for wash down cleaning with caustic solutions
- AquaPruf Ultimate 3-A models available. See page 45.



STANDARD FEATURE:
Positively driven drive sprockets and belt to avoid belt slipping



STANDARD FEATURE:
Integrated UHMW Return Shoe provides positive belt control and sprocket engagement



STANDARD FEATURE:
Tip-Up Tail**

AquaPruf Positive Drive Belt End Drive Conveyor																		
74	P	M	WWW	-	LLLL	D	I	A	1	S	S	PP	PP	BB	-	X	T ¹	T ²
															- Conveyor Tail Options X (if required)			
															K = Keyed Shaft		Ø = No Keyed Auxiliary Shaft	
															- Belt Type: 01 = White Smooth Top 02 = Blue Smooth Top Blue			
															- Profile (D side)			
															- Profile (A side)			
															01 = Low Side 02 = 25 mm (1 in) Integral Stainless Steel High Side 04 = 75 mm (3 in) UHMW High Side			
															06 = 152 mm (6 in) UHMW High Side 13 = Fully Adjustable Round 14 = Tool-less Fully Adjustable Round			
															23 = 75mm (3 in) Tall Stainless Steel High Side 26 = 152mm (6 in) Tall Stainless Steel High Side			
															- Idler Stand Location:			
															A = No Stand Mount Mounting brackets B = 300 mm (11.8 in) from end C = 450 mm (17.7 in) from end D = 600 mm (23.6 in) from end			
															E = 750 mm (29.5 in) from end F = 900 mm (35.4 in) from end G = 300 mm (11.8 in) from end with braces H = 450 mm (17.7 in) from end with braces			
															J = 600 mm (23.6 in) from end with braces K = 750 mm (29.5 in) from end with braces M = 900 mm (35.4 in) from end with braces			
															- Drive Stand Location:			
															A = No Stand Mount Mounting brackets B = 300 mm (11.8 in) from end C = 450 mm (17.7 in) from end D = 600 mm (23.6 in) from end			
															G = 300 mm (11.8 in) from end with braces H = 450 mm (17.7 in) from end with braces J = 600 mm (23.6 in) from end with braces			
															- Cleaning Option/Scrapper: 0 = None 1 = Frame Cut Outs only 2 = Belt Lifters only 3 = Frame Cut Out and Belt Lifters 4 = Scrapper only			
															5 = Frame Cut Outs and Scrapper 6 = Belt Lifters and Scrapper 7 = Frame Cut Out, Belt Lifters, and Scrapper			
															- Drive Shaft Position: A or D			
															- Infeed Tail Type/V-guide: 1 = Standard without V-guide			
															- Drive Tail Type/Bedplate: 1 = Customer Supplied Motor Standard Tail 2 = Side drive standard tail 3 = Motorized roller standard tail			
															- Conveyor Length (mm): 00915 to 12190 in 5 mm increments (36 - 480 in)			
															- Conveyor Width Reference (mm): = 0152 to 1219 (6 - 48 in)			
															- Documentation Language: M = US English			

* Conveyor load capacity depends on conveyor size, incline, motor position, accumulated loads and other factors. ** Note: Do not run the conveyor with the tail in the tip-up position.

Order gearmotor mounting packages and gearmotors separately, see pages 48-51.
For support stands and accessories, see page 53-56.

POSITIVE DRIVE BELT END DRIVE



See page 22 for side profile options

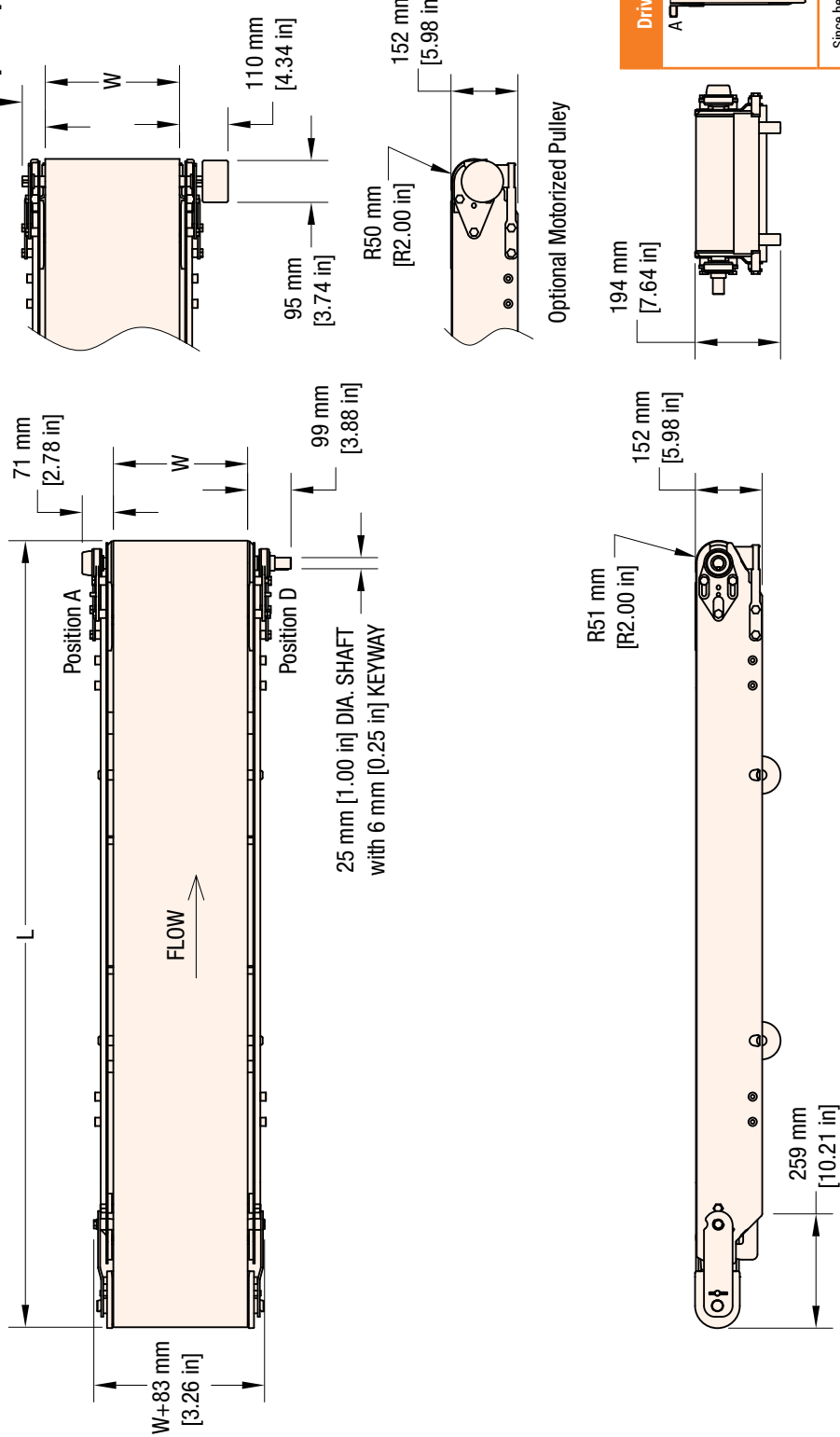

Drive Shaft Position

Since belts are being pulled, positions A & D are preferred. Pushing belts (B & C) reduces conveyor load capacity by approximately 66%.

W = Conveyor Belt Width Dim = mm (in)

STANDARD SIZES																	
Conveyor Width Reference	152	203	254	305	356	406	457	508	559	610	660	711	762	813	1118	1168	1219
Conveyor Belt Width (W)	152	203	254	305	356	406	457	508	559	610	660	711	762	813	1118	1168	1219
	(6)	(8)	(10)	(12)	(14)	(16)	(18)	(20)	(22)	(24)	(26)	(28)	(30)	(32)	(44)	(46)	(48)
Conveyor Length Reference	00915																12190
Conveyor Length (L)	00915 (36)																12190 (480)

Due to the wide variety of drive set ups and applications, point of installation guarding is the responsibility of the end user.

POSITIVE DRIVE FLAT BELT PROFILES

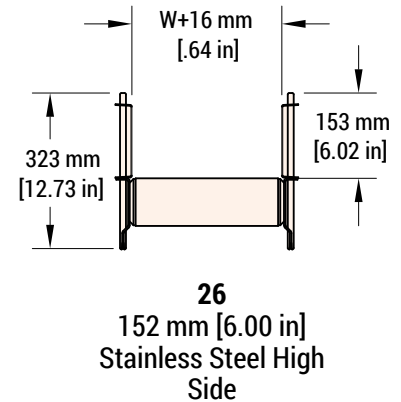
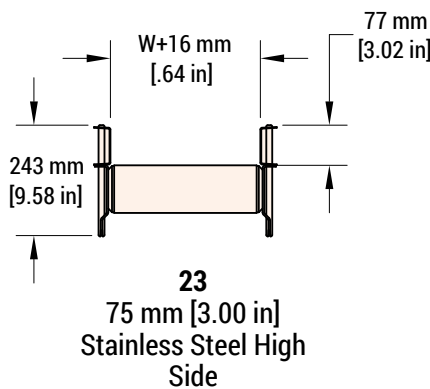
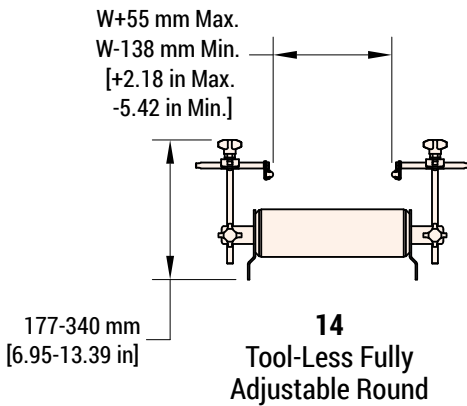
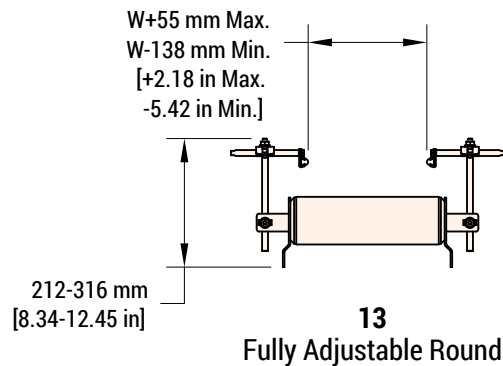
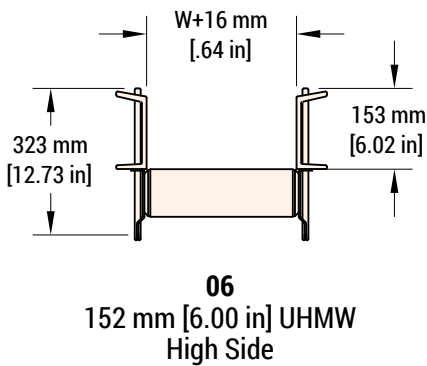
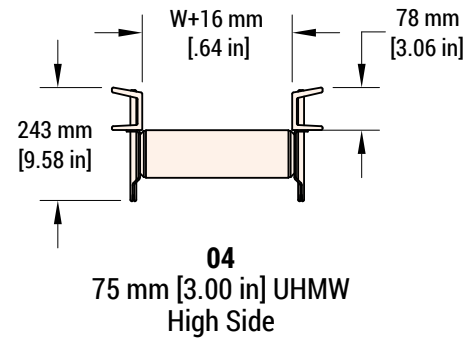
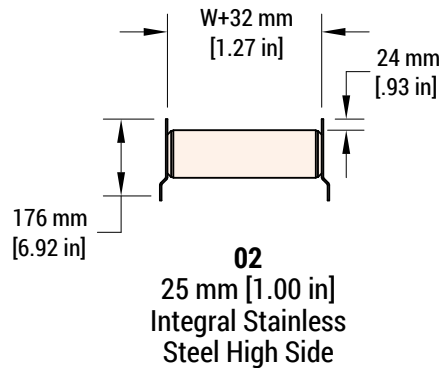
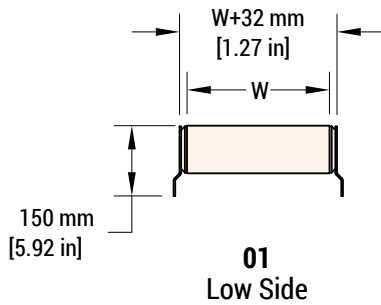

All AquaPruf stainless steel and UHMW guiding profiles are quick removal without tools for fast effective cleaning

W = Conveyor Belt Width Dim = mm (in)

Due to the wide variety of drive set ups and applications, point of installation guarding is the responsibility of the end user.



Standard Belt Selection Guide													Standard belt material is stocked at Dorner, then cut & spliced at the factory for fast conveyor shipment.	
Belt Type - Finger Splice	Belt Type - Plastic Clipper	Belt Type - Metal Clipper	Belt Specifications	V-Guidable	Belt Thickness	Surface Material	Maximum Part Temp. °C (°F)	Coefficient of Friction	FDA Approved	Anti-Static	Static Conductive	Chemical Resistance	Special Characteristics or Applications	
01	A1	1A	FDA Accumulation	x	1.7 (0.067)	Urethane	100 (212)	Low	x	x		Good	Packaging, clean room and inspection	
02	A2	2A	General Purpose	x	1.8 (0.071)	Urethane	100 (212)	Med	x	x		Good	Most versatile belt offering	
03	A3	3A	FDA High Friction	x	1.7 (0.067)	Urethane	100 (212)	High	x	x		Good	Packaging, clean room and inspection	
05	A5	5A	Accumulation	x	1.2 (0.047)	Urethane	100 (212)	V-Low	x	x		Good	Accumulation of products	
06	A6	6A	Electrically Conductive	x	1.6 (0.063)	Urethane	80 (176)	V-Low		x	x	Good	Electronics handling	
08	A8	8A	High Friction	x	2.1 (0.083)	PVC	70 (158)	V-High		x		Poor	Conveys up to 35° inclines*	
09			FDA High Friction	x	1.5 (0.059)	Urethane	100 (212)	High	x			Good	Lower no load torque	

Dim = mm (in)

Note: See below for splice details. Plastic Clipper splice requires longer lead times. Clipper splice not available on Z-Frame Series Conveyors.

Note: Belts with V-Guiding may have a slight high spot or rib on the top surface. This rib would run longitudinally along the center of the belt. Consult factory with applications for which this may cause interference.

*Incline varies due to factors like dust, fluids and part material.

Note: Wet applications are limited to specialty belt types 54, 55, 69 and 70 only (see next page).

BELT SPLICING



Finger Splice

All belts are available with a standard Thermoformed finger splice. This splice makes the belt continuous and is virtually undetectable. Splice bonding methods vary by belt type. Consult factory for details.

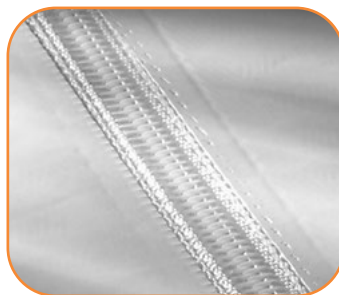

Plastic Clipper**

An optional plastic clipper splice is available for quick removal of belts or when conveyors are installed in tight spaces.

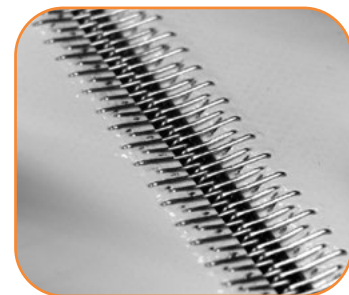

Metal Clipper**

An optional metal clipper splice is also available for quick removal of belts or when conveyors are installed in tight spaces.

** Plastic and Metal Clippers are slightly thicker than base belt. Contact factory for details.



Solid Urethane belt for added sanitary protection –
See belt type 70 below

High Release Cover belt for handling sticky food such as raw dough –
See belt type 71 below

Note: Wet applications are limited to specialty belt types 54, 55, 69 and 70 only.

Specialty Belt Selection Guide											
<i>Specialty belt material is not stocked at Dorner and needs to be custom ordered for your special conveyor needs.</i>											
Belt Type - Finger Splice	Belt Type - Plastic Clipper	Belt Type - Metal Clipper**	Belt Specifications	Belt Thickness	Surface Material	Maximum Part Temp. °C (°F)	Coefficient of Friction	FDA Approved	Chemical Resistance	Moisture Resistance	Special Characteristics or Applications
54	F4	4F	FDA Sealed Edge	1.5 (0.06)	Urethane	80 (176)	Low	x	Good	Good	Packaging, clean room & inspection, wet environment
55	F5	5F	FDA Sealed Edge	1.5 (0.06)	Urethane	80 (176)	High	x	Good	Good	Packaging, clean room & inspection, wet environment
56		6F	Cut Resistant	2.1 (0.08)	Urethane	100 (212)	Med.		Good	Poor	Oily product release, Metal stamping
57		7F	Cut Resistant	2.5 (0.10)	Nitrile	80 (176)	Med.		Poor	Poor	Felt-like, dry metal stamping, glass & ceramic
59	F9	9F	Color Contrasting	1.5 (0.06)	PVC	70 (158)	Med.		Poor	Poor	Black colored, hides overspray from ink jet
60	G0	0G	Color Contrasting	1.2 (0.05)	Urethane	100 (212)	Low	x	Good	Poor	Green colored, Nose Bar
61	G1	1G	Color Contrasting	1.2 (0.05)	Urethane	100 (212)	Low	x	Good	Poor	Blue colored, Nose Bar
63		3G	Electrically Conductive	1.2 (0.05)	Urethane	60 (140)	Low		Good	Poor	Static conductive, electronics handling
64		4G	High Friction	4.4 (0.17)	PVC	90 (194)	V-High		Poor	Poor	Dark Green colored, rough top surface, product cushioning, incline / decline apps
66		6G	Chemical Resistant	1.7 (0.07)	Polyester	100 (212)	Med.	x	V-Good	Poor	Good Cut resistance, metal stamping apps
67		7G	Low Friction Cleated	1.6 (0.06)	Polyester	100 (212)	n/a	x	Good	Poor	Excellent product release, consult factory for part number and how to specify low friction
68	G8		FDA Encased*	2.0 (0.08)	Urethane	100 (212)	Low	x	Good	V-Good	Urethane Enclosed for added sanitary protection
69	G9		FDA Encased*	2.0 (0.08)	Urethane	100 (212)	High	x	Good	V-Good	Urethane Enclosed for added sanitary protection
70			Solid Urethane	2.5 (0.10)	Urethane	100 (212)	Med.	x	Good	V-Good	USDA Approved, wet applications
71			High Release Cover	1.7 (0.07)	Urethane	100 (212)	Low	x	Good	Poor	Raw dough or sticky food product
72			Nose Bar Low Friction	1.2 (0.05)	Urethane	100 (212)	Low	x	Good	Poor	Nose Bar Applications

Dim = mm (in)

Metal Clipper Splices are not available on belts over 1219 mm (48 in) wide.

* Not available in 51 mm (2 in) wide.

**Metal Clipper splices are not sanitary.

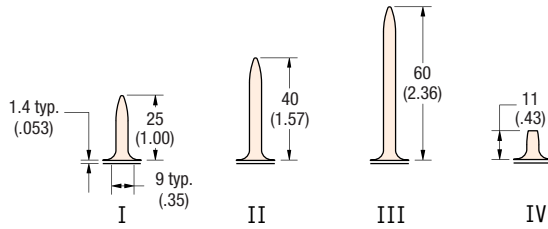

Standard Cleated Belt Selection Guide

Part No.	Base Belt	Belt Thickness, mm (in)	Belt Surface Material	Cleat Height, mm (in)	Cleat Material	Maximum Part Temp. °C (°F)	FDA Approved	Chemical Resistance	Moisture Resistance	Illustration
A	High Friction	1.4 (0.055)	Urethane	25 (1.00)	Urethane	80 (176)	Yes	Good	Poor	I
B	High Friction	1.4 (0.055)	Urethane	40 (1.57)	Urethane	80 (176)	Yes	Good	Poor	II
C	High Friction	1.4 (0.055)	Urethane	60 (2.36)	Urethane	80 (176)	Yes	Good	Poor	III
G	High Friction	1.4 (0.055)	Urethane	11 (0.43)	Urethane	80 (176)	Yes	Good	Poor	IV
J	Low Friction	1.6 (0.06)	Urethane	25 (1.00)	Urethane	100 (212)	Yes	Good	Poor	I
K	Low Friction	1.6 (0.06)	Urethane	40 (1.57)	Urethane	100 (212)	Yes	Good	Poor	II
L	Low Friction	1.6 (0.06)	Urethane	60 (2.36)	Urethane	100 (212)	Yes	Good	Poor	III
M	Low Friction	1.6 (0.06)	Urethane	11 (0.43)	Urethane	100 (212)	Yes	Good	Poor	IV

CLEATED BELT SPACING

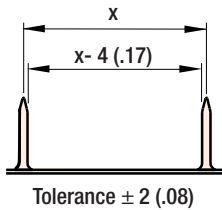

- Cleat spacing is determined by conveyor length and desired number of cleats
- Minimum spacing = 50 mm (2 in)
- Spacing accuracy = ± 2 mm (.08 in)
- Maximum 2135 mm (84 in) conveyor length for 487 mm (18 in) and wider conveyors
- Maximum 508 mm (20 in) cleat spacing for 2135 mm (84 in) and longer conveyors
- For Lengths > 24' Tolerance ± 5 [.20]

Dim = mm (in)

SPECIALTY CLEATED BELT PROFILES

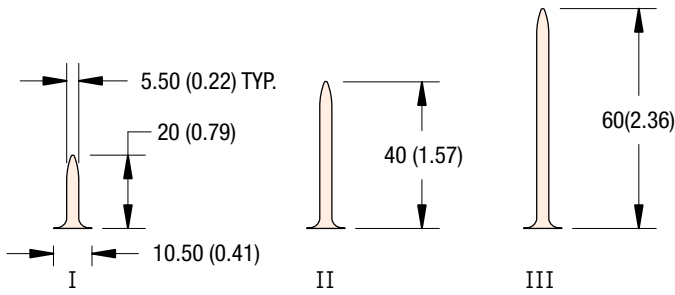

W = Conveyor Belt Width

A = Pocket Width

A = W - 116 mm (4.57 in)

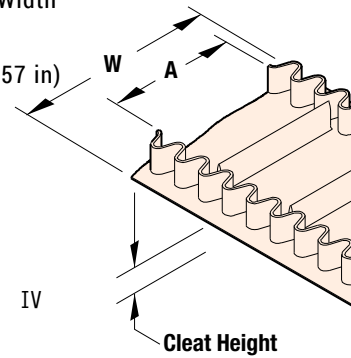

Specialty Cleated Belt Selection Guide

Part No.	Base Belt	Belt Thickness, mm (in)	Belt Surface Material	Cleat Height, mm (in)	Cleat Material	Maximum Part Temp. °C (°F)	FDA Approved	Chemical Resistance	Moisture Resistance	Illustration
Cleated	N Sealed Edge	1.5 (0.06)	Urethane	20 (0.79)	Urethane	80 (176)	Yes	Good	Good	I
	P Sealed Edge	1.5 (0.06)	Urethane	40 (1.57)	Urethane	80 (176)	Yes	Good	Good	II
	Q Sealed Edge	1.5 (0.06)	Urethane	60 (2.36)	Urethane	80 (176)	Yes	Good	Good	III
	R Encased	2.0 (0.08)	Urethane	0.79 (20)	Urethane	100 (212)	Yes	Good	Very Good	I
	S Encased	2.0 (0.08)	Urethane	40 (1.57)	Urethane	100 (212)	Yes	Good	Very Good	II
	T Encased	2.0 (0.08)	Urethane	60 (2.36)	Urethane	100 (212)	Yes	Good	Very Good	III
Sidewall Cleated	U Standard	1.5 (0.06)	Urethane	30 (1.18)	Urethane	80 (176)	Yes	Good	Poor	IV
	V Standard	1.5 (0.06)	Urethane	50 (1.97)	Urethane	80 (176)	Yes	Good	Poor	IV
	W Sealed Edge	1.5 (0.06)	Urethane	30 (1.18)	Urethane	80 (176)	Yes	Good	Good	IV
	X Sealed Edge	1.5 (0.06)	Urethane	50 (1.97)	Urethane	80 (176)	Yes	Good	Good	IV
	Y Encased	1.5 (0.06)	Urethane	30 (1.18)	Urethane	80 (176)	Yes	Good	Very Good	IV
	Z Encased	1.5 (0.06)	Urethane	50 (1.97)	Urethane	80 (176)	Yes	Good	Very Good	IV

SPECIALTY CLEATED BELT SPACING

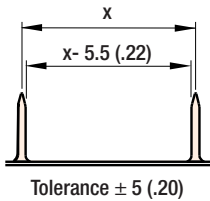

- Cleat spacing is determined by conveyor length and desired number of cleats
- Minimum spacing = 50 mm (2 in)
- Spacing accuracy = ±5 mm [0.2 in]
- Maximum 2135 mm (84 in) conveyor length for 487 mm (18 in) and wider conveyors
- Maximum 508 mm (20 in) cleat spacing for 2135 mm (84 in) and longer conveyors

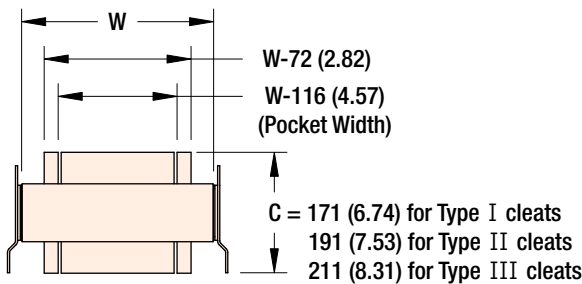

Sidewall Belting

Dim = mm (in)

POSITIVE DRIVE BELTING

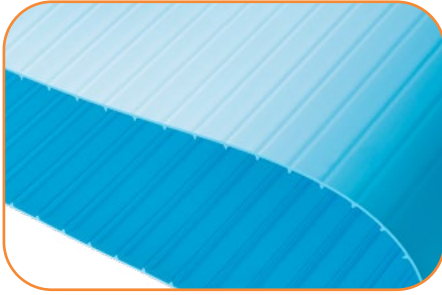

Specifications

- Solid Urethane material
- Drive lugs on 25 mm (1 in) spacing
- Available in Blue or White
- Excellent abrasion and tear resistance

(Also available in white)

Positive Drive Belt Selection Guide

Description	Surface Material	Belt Thickness, mm (in)	Maximum Part Temp. C (F)	Sanitation Temperature °C (°F)	USDA Approval	Chemical Resistance	Special Characteristics
Flat Belt Smooth, Matte Finish	Homogeneous Thermoplastic, FDA Compliant Polyurethane 01 Smooth top white 02 Smooth top blue	6 mm (0.236 in)	-28 to 80 (-20 to 176)	up to 85 (185)	x	Very Good	Smooth Surface

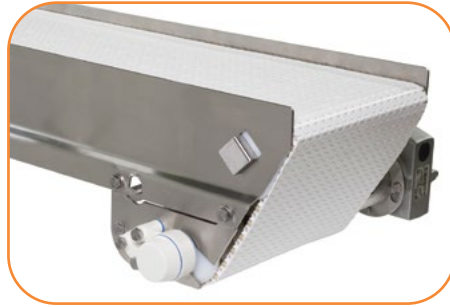

NOSEBAR DRIVE AND IDLER OPTIONS
FOR TRANSFER OF SMALL PRODUCTS



PATENTED SPROCKET ALIGNMENT KEY

PROVIDES CONTINUOUS SPROCKET ALIGNMENT FOR QUICK BELT SANITATION AND ASSEMBLY

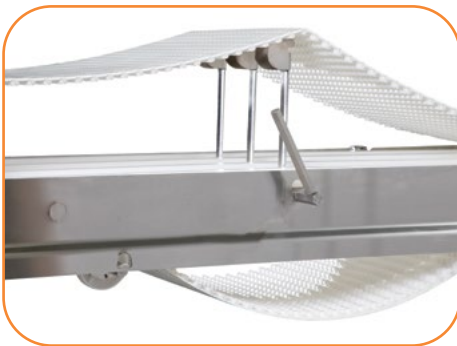

BELT LIFTER
FOR EASY CLEANING ON WIDE OR LONG CONVEYORS



TIP-UP TAIL
FOR QUICK RELEASE OF BELT TENSION



QUICK REMOVAL SIDE MOUNT GEARMOTOR
TO REDUCE SANITATION TIME

*Note: Do not run the conveyor with the tail in the tip-up position.



AquaPruf iDRIVE2 MOTORIZED ROLLER

NEW GEARLESS, OIL-FREE TECHNOLOGY PROVIDES FOOD SAFE COMPACT FOOTPRINT



STAINLESS STEEL GEARMOTORS

LOCATED OUTSIDE OF FOOD ZONE



USDA ACCEPTED OPEN HINGE MODULAR BELT

IMPROVES CLEANING AND ACCESS TO PINS



SOLID UHMW WEAR STRIPS

QUICKLY REMOVED WITHOUT TOOLS FOR CLEANING. MOST PIECES ARE IDENTICAL AND COMPLETELY INTERCHANGEABLE.



STAINLESS STEEL WELDED FRAME CONSTRUCTION

ELIMINATES FASTENERS IN FOOD ZONE (CONTINUOUS TIG WELDING)



Specifications

- Loads up to 341 kg (750 lbs) or 98 kg/sq m (20 lbs/sq ft)*
- Belt speeds up to 78.6 m/min (260 ft/min)
- Belt widths: 150 mm (5.9 in) to 1200 mm (47.3 in)
- Conveyor lengths: 915 mm (36 in) to 25000 mm (984 in)
- Continuous TIG Welded 304 Stainless Steel Frame
- 400 Series Stainless Steel bearing with FDA H1 food grade grease
- FDA approved belting and plastic components
- Open design with minimal horizontal surfaces
- Suitable for use in raw food applications
- Stainless Steel construction for wash down cleaning with caustic solutions
- One revolution of 99 mm (3.9 in) pitch sprocket moves the belt approximately 305 mm (12.0 in)
- AquaPruf Ultimate 3-A models available. See page 45.



STANDARD: Tip-Up Tail**



OPTIONAL: Nose Bar Idler Tail
25 mm (1 in) diameter for small parts transfer. Speeds up to 79 m/min (260 ft/min)



OPTIONAL: Nose Bar Drive Tail
25 mm (1 in) diameter for small parts transfer. Speeds up to 79 m/min (260 ft/min)

AquaPruf Modular Flat Belt End Drive Conveyor

74 B M WWW - L L L L L D I A 1 S S P P P P B B - X T¹ T²

- Conveyor Tail Options X (if required)
0 = No shaft (3 and 4 always 0 for tip-up tail), K = Keyed Shaft
- Belt Type: Chain See Pages 42-43 for belt selection
- Profile (D side)
- Profile (A side)
01 = Low Side 02 = 25 mm (1 in) Integral Stainless Steel High Side 04 = 75 mm (3 in) UHMW High Side
06 = 152 mm (6 in) UHMW High Side 13 = Fully Adjustable Round 14 = Tool-less Fully Adjustable Round
23 = 75mm (3 in) Tall Stainless Steel High Side 26 = 152mm (6 in) Tall Stainless Steel High Side0.
- Idler Stand Location: Note: Tip-up tail start at 18"
A = No Stand Mount Mounting brackets B = 300 mm (11.8 in) from end C = 450 mm (17.7 in) from end D = 600 mm (23.6 in) from end
E = 750 mm (29.5 in) from end F = 900 mm (35.4 in) from end G = 300 mm (11.8 in) from end with braces H = 450 mm (17.7 in) from end with braces
J = 600 mm (23.6 in) from end with braces K = 750 mm (29.5 in) from end with braces M = 900 mm (35.4 in) from end with braces
- Drive Stand Location:
A = No Stand Mount Mounting brackets B = 300 mm (11.8 in) from end C = 450 mm (17.7 in) from end D = 600 mm (23.6 in) from end
G = 300 mm (11.8 in) from end with braces H = 450 mm (17.7 in) from end with braces J = 600 mm (23.6 in) from end with braces
- Cleaning Option/Scraper: 0 = None 1 = Frame Cut Outs only 2 = Belt Lifters only 3 = Frame Cut Out and Belt Lifters
- Drive Shaft Position: A or D
- Idler Tail Type: 1 = Standard 2 = Nose Bar
- Drive Tail Types: 1 = Customer Supplied Motor Standard Tail 2 = Side Drive Standard Tail 3 = Motorized Roller Standard Tail
4 = Customer Supplied Motor Nose Bar Drive 5 = Side Drive Nosebar Roller Tail
- Conveyor Length (mm): 00915 to 25000 in 5 mm increments (36 - 984 in)
- Conveyor Width Reference (mm): = 0150 to 1200 (5.9 - 47.3 in)
- Documentation Language: M = US English

* Conveyor load capacity depends on conveyor size, incline, motor position, accumulated loads and other factors.

** Note: Do not run the conveyor with the tail in the tip-up position.

Order gearmotor mounting packages and gearmotors separately, see pages 48-51.
For support stands and accessories, see page 53-56.

STRAIGHT MODULAR FLAT BELT



SANITARY OPTIONS



FRAME CUTOUTS



NOSEBAR



BELT LIFTER



iDRIVE 2

MOTORIZED ROLLER

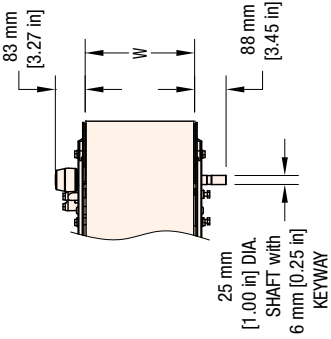
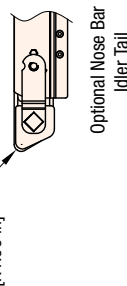
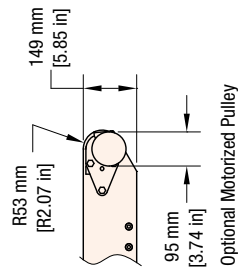
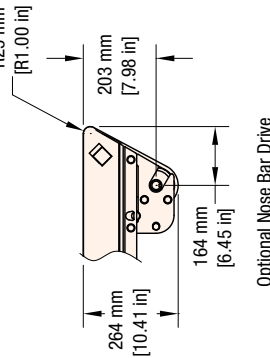
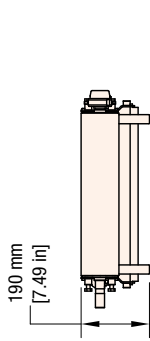
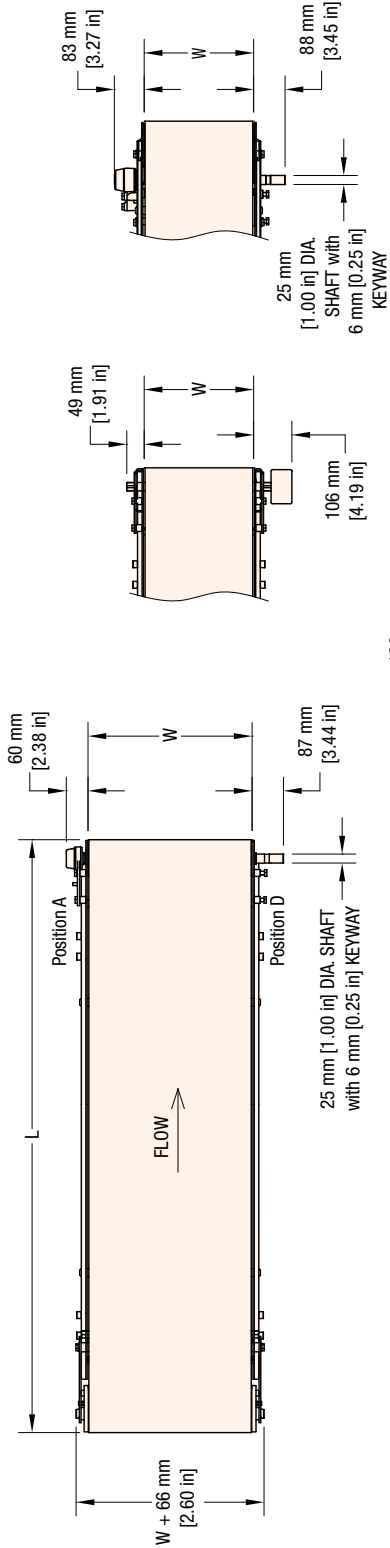

DRIVE SHAFT POSITION

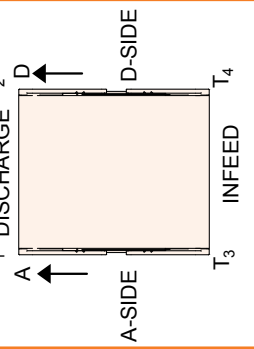

See page 40 for side profile options

W = Conveyor Belt Width Dim = mm (in)

STANDARD SIZES						
Conveyor Width Reference	150	200	250	50 increments up to...	1100	1200
Conveyor Belt Width (W)	150	200	250	50 mm increments up to...	1100	1200
	(5.9)	(7.9)	(9.8)	1.97 in increments up to...	(43.3)	(47.3)
Conveyor Length Reference	00915			00005 increments up to...	12190	
Conveyor Length (L)	00915 (36)			00005 (0.2) increments up to...	12190 (480)	

Due to the wide variety of drive set ups and applications, point of installation guarding is the responsibility of the end user.

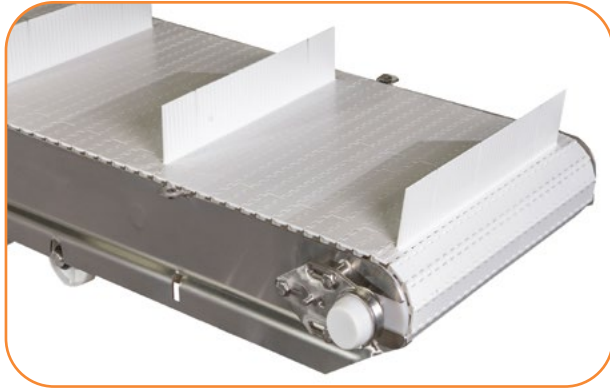

Specifications

- Loads up to 341 kg (750 lbs) or 98 kg/sq m (20 lbs/sq ft)*
- Belt speeds up to 78.6 m/min (260 ft/min)
- Belt widths: 200 mm (7.9 in) to 600 mm (23.6 in)
- Conveyor lengths: 915 mm (36 in) to 25000 mm (984 in)
- Cleat heights from 25 mm (1 in) to 75 mm (3 in)
- Continuous TIG Welded 304 Stainless Steel Frame
- 400 Series Stainless Steel bearing with FDA H1 food grade grease
- FDA approved belting and plastic components
- Open design with minimal horizontal surfaces
- Suitable for use in raw food applications
- Stainless Steel construction for wash down cleaning with caustic solutions
- AquaPruf Ultimate 3-A Certified available. See page 45.



STANDARD:
Tip-Up Tail**



OPTIONAL:
High Side Guides
Up to 152 mm (6 in) tall



OPTIONAL:
Frame Cutouts and/or Lifters

AquaPruf Modular Cleated Belt End Drive Conveyor																		
74	F	M	WWW	-	LLLL	D	I	A	T	S	S	PP	SS	BB	-	X	T ¹	T ²
															- Conveyor Tail Options X (if required) O = No shaft K = Keyed Shaft - Cleat Spacing: 01 - 99 (links) - Belt Type: Chain See Pages 42-43 for belt selection - Profile 01 = Low Side 04 = 75mm (3 in) UHMW High Side 06 = Cleated 152mm (6 in) UHMW High Side 23 = 75mm (3 in) Tall Stainless Steel High Side 26 = 152mm (6 in) Tall Stainless Steel High Side - Idler Stand Location: A = No Stand Mount Mounting brackets B = 300 mm (11.8 in) from end C = 450 mm (17.7 in) from end D = 600 mm (23.6 in) from end E = 750 mm (29.5 in) from end F = 900 mm (35.4 in) from end G = 300 mm (11.8 in) from end with braces H = 450 mm (17.7 in) from end with braces J = 600 mm (23.6 in) from end with braces K = 750 mm (29.5 in) from end with braces M = 900 mm (35.4 in) from end with braces - Drive Stand Location: A = No Stand Mount Mounting brackets B = 300 mm (11.8 in) from end C = 450 mm (17.7 in) from end D = 600 mm (23.6 in) from end G = 300 mm (11.8 in) from end with braces H = 450 mm (17.7 in) from end with braces J = 600 mm (23.6 in) from end with braces - Cleaning Option/Scraper: 0 = None 1 = Frame Cut Outs only 2 = Belt Lifters only 3 = Frame Cut Out and Belt Lifters - Drive Shaft Position: A or D - Idler Tail Type: 1 = Standard - Drive Tail Types: 1 = Customer Supplied Motor Standard Tail 2 = Side Drive Standard Tail 3 = Motorized Roller Standard Tail - Conveyor Length (mm): 00915 to 25000 in 5 mm increments (36 - 984 in) - Conveyor Width Reference (mm): = 200 to 600 (7.9 - 23.6fd in) - Documentation Language: M = US English			

* Conveyor load capacity depends on conveyor size, incline, motor position, accumulated loads and other factors.

** Note: Do not run the conveyor with the tail in the tip-up position.

Order gearmotor mounting packages and gearmotors separately, see pages 48-51.
For support stands and accessories, see page 53-56.

STRAIGHT MODULAR CLEATED BELT



SANITARY
OPTIONS



FRAME CUTOUTS



BELT LIFTER



DRIVE 2
MOTORIZED ROLLER

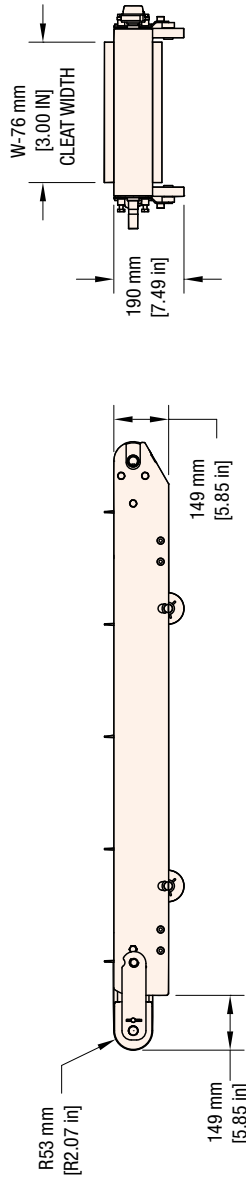
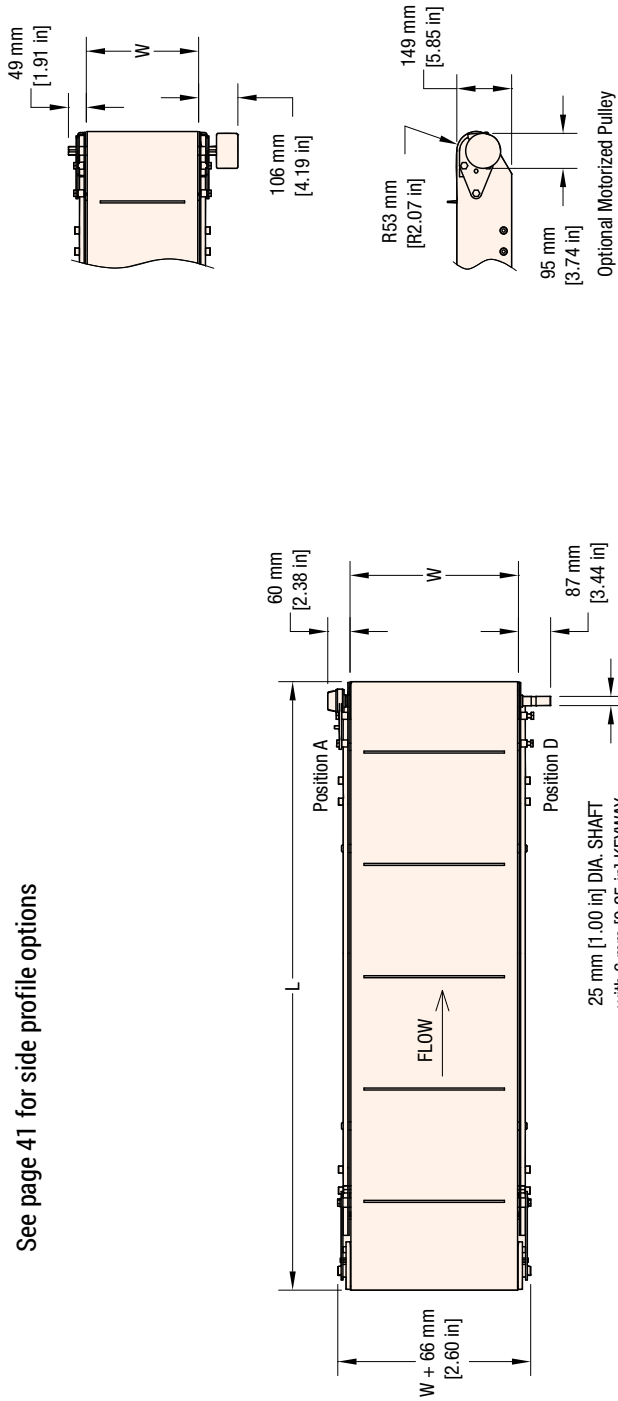

DRIVE SHAFT POSITION

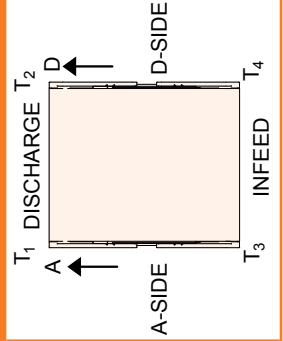

See page 41 for side profile options

W = Conveyor Belt Width Dim = mm (in)

STANDARD SIZES									
Conveyor Width Reference	200	250	300	350	400	450	500	550	600
Conveyor Belt Width (W)	200	250	300	350	400	450	500	550	600
	(7.9)	(9.8)	(11.8)	(13.8)	(15.7)	(17.7)	(19.7)	(21.7)	(23.6)
Conveyor Length Reference	00915								
Conveyor Length (L)	00005 increments up to...								
	0915 (36)	00005 (0.2) increments up to...							25000 (984)

Due to the wide variety of drive set ups and applications, point of installation guarding is the responsibility of the end user.

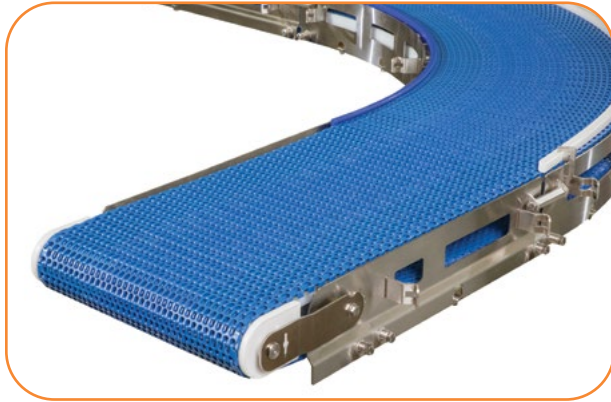

Specifications

- Loads up to 227 kg (500 lbs) or 98 kg/sq m (20 lbs/sq ft)*
- Belt speeds up to 78.6 m/min (260 ft/min)
- Belt widths: 152 mm (6 in) to 914 mm (36 in)
- Conveyor section lengths: 460 mm (18 in) to 15240 mm (600 in)
- Curve angles of 15, 30, 45, 60, 75, 90, 135 and 180 degrees
- Continuous TIG Welded 304 Stainless Steel Frame
- Up to curves driven by one gearmotor
- FDA approved belting and plastic components
- Suitable for use in raw food applications
- Stainless Steel construction for wash down cleaning with caustic solutions

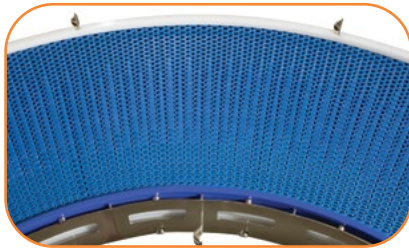

Curve Innovation
Improved chain strength provides capability for 3 curves on one gearmotor



STANDARD: Tip-Up Tail**

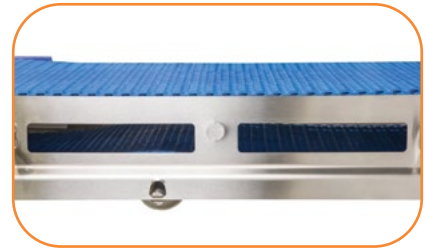

OPTIONAL: Frame Cutouts and/or Lifters

Multiple Curve Configurations

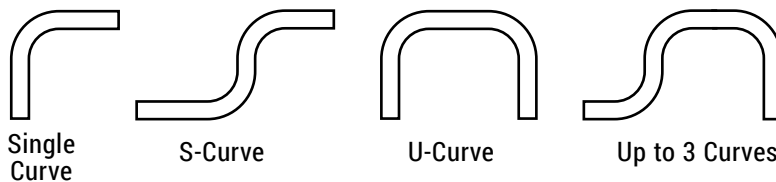

* Conveyor load capacity depends on conveyor size, incline, motor position, accumulated loads and other factors.

Order gearmotor mounting packages and gearmotors separately, see pages 48-51.
For support stands and accessories, see page 53-56.

CURVED MODULAR FLAT BELT



See page 40 for side profile options

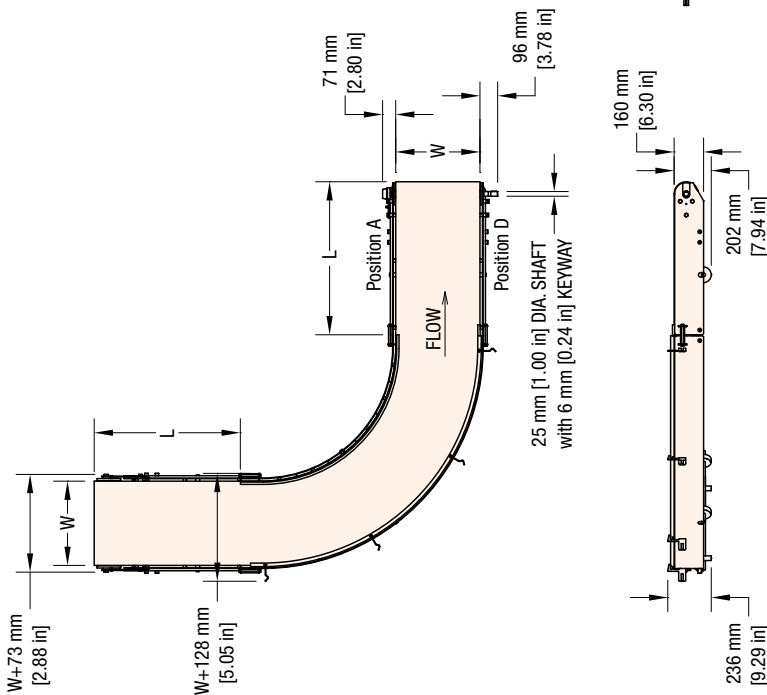

Belt Width Table		
Curve Width	Actual Belt width	Inside belt radius
152	149mm (5.9 in)	243mm (9.6 in)
229	226mm (8.9 in)	366mm (14.4 in)
305	302mm (11.9 in)	488mm (19.2 in)
381	379mm (14.9 in)	610mm (24.0 in)
457	455mm (17.9 in)	731mm (28.8 in)
533	531mm (20.9 in)	853mm (33.6 in)
610	608mm (23.9 in)	976mm (38.4 in)
686	684mm (26.9 in)	1098mm (43.2 in)
762	761mm (30.0 in)	1219mm (48.0 in)
838	837mm (33.0 inch)	1341mm (52.8 in)
914	914mm (36.0 inch)	1462mm (57.6 in)

W = Conveyor Belt Width Dim = mm (in)

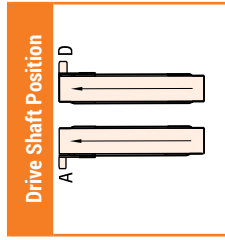

STANDARD SIZES											
Conveyor Width Reference	152	229	305	381	457	533	610	686	762	838	914
Conveyor Belt Width (W)	152	229	305	381	457	533	610	686	762	838	914
	(6)	(9)	(12)	(15)	(18)	(21)	(24)	(27)	(30)	(33)	(36)
Conveyor Length Reference	00460 increments up to...										
Conveyor Length (L)	00460 (18)	00005 (0.2) increments up to...									
											15240 (600)

NOTE: Total length of all sections cannot exceed 25000 mm (984 in)
Maximum of 3 curves

Due to the wide variety of drive set ups and applications, point of installation guarding is the responsibility of the end user.

AquaPruf Curved Modular Belt Conveyor - Infeed Module

74 T 1 M WWW - L L L L L I 1 S P P P P B B - S S

- Sequence 01 to 99
- Belt Type: Chain See Pages 42-43 for belt selection
- Profile (D side)
- Profile (A side)
 - 01 = Low Side 13 = Fully Adjustable Round 14 = Tool-less Fully Adjustable Round
 - 23 = 75mm (3 in) Tall Stainless Steel High Side 26 = 152mm (6 in) Tall Stainless Steel High Side
- Idler Stand Location:
 - A = No Stand Mount Mounting brackets B = 300 mm (11.8 in) from end C = 450 mm (17.7 in) from end D = 600 mm (23.6 in) from end
 - E = 750 mm (29.5 in) from end F = 900 mm (35.4 in) from end G = 300 mm (11.8 in) from end with braces H = 450 mm (17.7 in) from end with braces
 - J = 600 mm (23.6 in) from end with braces K = 750 mm (29.5 in) from end with braces M = 900 mm (35.4 in) from end with braces
- Cleaning Option/Scraper: 0 = None 1 = Frame Cut Outs only 2 = Belt Lifters only 3 = Frame Cut Out and Belt Lifters
- Idler Tail Type: 1 = Standard
- Conveyor Length (mm): 00500 to 15240 in 5 mm increments (20 to 600 in)
- Conveyor Width Reference (mm): = 152 to 914 (6 to 36 in)
- Documentation Language: M = US English
- Module Type: 1 = Infeed Module
- Conveyor Type: T = Modular Belt Curve

AquaPruf Curved Modular Belt Conveyor - Curve Module

74 T 2 M WWW - A A A I 1 P P P P B B - S S

- Sequence 01 to 99
- Belt Type: Chain See Pages 42-43 for belt selection
- Profile (D side)
- Profile (A side)
 - 01 = Low Side 13 = Fully Adjustable Round 14 = Tool-less Fully Adjustable Round
 - 23 = 75mm (3 in) Tall Stainless Steel High Side 26 = 152mm (6 in) Tall Stainless Steel High Side
- Cleaning Option/Scraper: 0 = None 1 = Frame Cut Outs only
- Direction: L = Left Hand Turn R = Right Hand Turn
- Degrees of Turn: = 015, 030, 045, 060, 075, 090, 135 or 180
- Conveyor Width Reference (mm): = 152 to 914 (6 to 36 in)
- Documentation Language: M = US English
- Module Type: 2 = Curve Module
- Conveyor Type: T = Modular Belt Curve

AquaPruf Curved Modular Belt Conveyor - Intermediate Module

74 T 3 M WWW - L L L L L I 1 S P P P P B B - S S

- Sequence 01 to 99
- Belt Type: Chain See Pages 42-43 for belt selection
- Profile (D side)
- Profile (A side)
 - 01 = Low Side 13 = Fully Adjustable Round 14 = Tool-less Fully Adjustable Round
 - 23 = 75mm (3 in) Tall Stainless Steel High Side 26 = 152mm (6 in) Tall Stainless Steel High Side
- Stand Style: A = No Braces B = Braces
- Cleaning Option/Scraper: 0 = None 1 = Frame Cut Outs only 2 = Belt Lifters only 3 = Frame Cut Out and Belt Lifters
- Conveyor Length (mm): 00500 to 15240 in 5 mm increments (20 to 600 in)
- Conveyor Width Reference (mm): = 152 to 914 (6 to 36 in)
- Documentation Language: M = US English
- Module Type: 3 = Intermediate Module
- Conveyor Type: T = Modular Belt Curve

AquaPruf Curved Discharge Modular Belt Conveyor - Drive Modular

74 T 5 M WWW - L L L L L I A 1 S P P P P B B - S S

- Sequence 01 to 99
- Belt Type: Chain See Pages 42-43 for belt selection
- Profile (D side)
- Profile (A side)
 - 01 = Low Side 13 = Fully Adjustable Round 14 = Tool-less Fully Adjustable Round
 - 23 = 75mm (3 in) Tall Stainless Steel High Side 26 = 152mm (6 in) Tall Stainless Steel High Side
- Drive Stand Location:
 - A = No Stand Mount Mounting brackets B = 300mm (11.8 in) from end C = 450 mm (17.7 in) from end D = 600 mm (23.6 in) from end
 - G = 300 mm (11.8 in) from end with braces H = 450 mm (17.7 in) from end with braces J = 600 mm (23.6 in) from end with braces
- Cleaning Option/Scraper: 0 = None 1 = Frame Cut Outs only 2 = Belt Lifters only 3 = Frame Cut Out and Belt Lifters
- Drive Position: A or D
- Drive Tail Type: 1 = Customer Supplied Motor Standard Tail 2 = Side Drive Standard Tail
- Conveyor Length (mm): 00500 to 15240 in 5 mm increments (20 to 600 in)
- Conveyor Width Reference (mm): = 152 to 914 (6 to 36 in)
- Documentation Language: M = US English
- Module Type: 5 = Drive Module
- Conveyor Type: T = Modular Belt Curve

Minimum Curve Section Lengths:

Single Curve

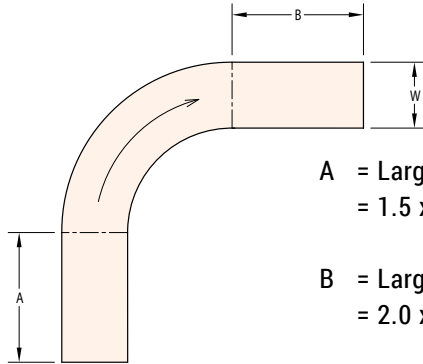

A = Lagers of (2)
= 1.5 x W or 500 mm (19.7 in)

B = Lagers of (2)
= 2.0 x W or 500 mm (19.7 in)

Single Curve		
Width	A	B
152	500	500
229	500	500
305	500	610
381	570	765
457	685	915
533	800	1070
610	915	1220
686	1025	1375
762	1140	1525
838	1255	1680
914	1370	1830

S-Curve

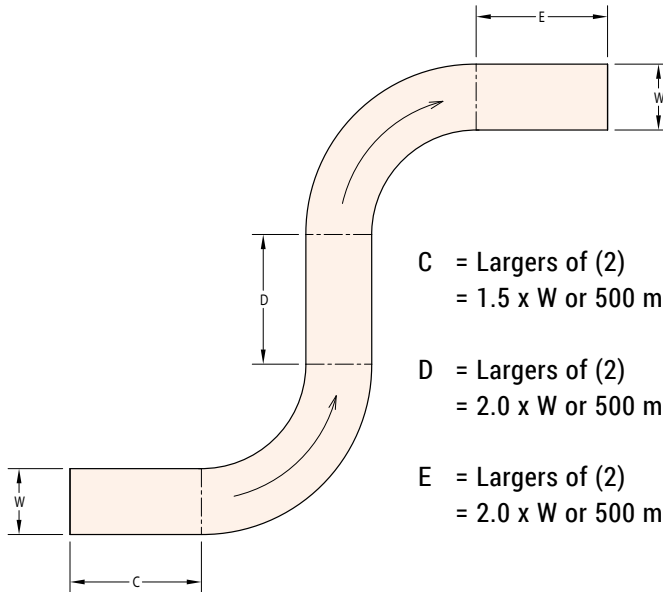

C = Lagers of (2)
= 1.5 x W or 500 mm (19.7 in)

D = Lagers of (2)
= 2.0 x W or 500 mm (19.7 in)

E = Lagers of (2)
= 2.0 x W or 500 mm (19.7 in)

S Curve			
Width	C	D	E
152	500	500	500
229	500	500	500
305	500	610	610
381	570	765	765
457	685	915	915
533	800	1070	1070
610	915	1220	1220
686	1025	1375	1375
762	1140	1525	1525
838	1255	1680	1680
914	1370	1830	1830

U-Curve

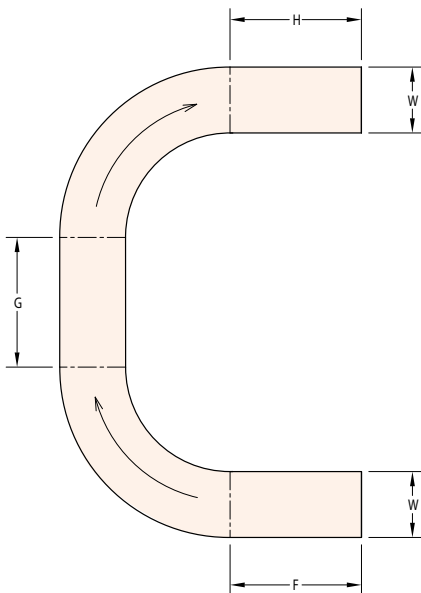

F = Lagers of (2)
= 1.5 x W or 500 mm (19.7 in)

G = 500 mm (19.7 in)

H = Lagers of (2)
= 2.0 x W or 500 mm (19.7 in)

U Curve			
Width	F	G	H
152	500	500	500
229	500	500	500
305	500	500	610
381	570	500	765
457	685	500	915
533	800	500	1070
610	915	500	1220
686	1025	500	1375
762	1140	500	1525
838	1255	500	1680
914	1370	500	1830



Specifications

- Loads up to 45 kg (100 lbs) or 98 kg/sq m (20 lbs/sq ft)*
- Belt speeds up to 78.6 m/min (260 ft/min)
- Belt widths: 200 mm (7.9 in) to 600 mm (23.6 in)
- Conveyor section lengths: 610 mm (24 in) to 6100 mm (240 in)
- Maximum total conveyor length of 25000 mm (984 in)
- Angles from 30 degrees to 60 degrees in 5 degree increments
- Continuous TIG Welded 304 Stainless Steel Frame
- FDA approved belting and plastic components
- Suitable for use in raw food applications
- Stainless Steel construction for wash down cleaning with caustic solutions
- AquaPruf Ultimate 3-A models available. See page 45.

Configurations

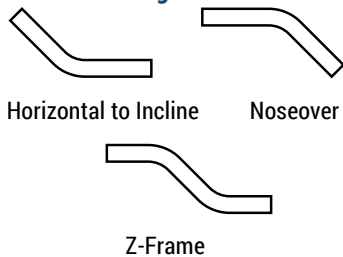

STANDARD:
Tip-Up Tail**



OPTIONAL: High Side Guides
Up to 152 mm (6 in) tall

AquaPruf LPZ (Z-Frame) Modular Cleated Conveyor

74	F	M	WWW	-	LLLLL	-	LLLLL	-	LLLLL	AA	E	D	I	A	T	S	S	P	BB	SS	-	X	T ¹	
																							- Conveyor Tail Options X (if required)	
																							0 = No shaft K = Keyed Shaft	
																							- Spacing: 01 - 99 (links)	
																							- Belt/Cleat Type: Chain See Pages 42-43 for belt selection	
																							- Profile:	
																							1 = Low Side 7 = 75mm (3 in) Tall Stainless Steel High Side 8 = 152mm (6 in) Tall Stainless Steel High Side	
																							- Idler Stand Location:	
																							A = No Stand Mount Mounting brackets B = 300 mm (11.8 in) from end C = 450 mm (17.7 in) from end	
																							D = 600 mm (23.6 in) from end E = 750 mm (29.5 in) from end F = 900 mm (35.4 in) from end	
																							G = 300 mm (11.8 in) from end with braces H = 450 mm (17.7 in) from end with braces	
																							J = 600 mm (23.6 in) from end with braces K = 750 mm (29.5 in) from end with braces	
																							M = 900 mm (35.4 in) from end with braces	
																							- Drive Stand Location:	
																							A = No Stand Mount Mounting brackets B = 300 mm (11.8 in) from end C = 450 mm (17.7 in) from end	
																							D = 600 mm (23.6 in) from end G = 300 mm (11.8 in) from end with braces H = 450 mm (17.7 in) from end with braces	
																							J = 600 mm (23.6 in) from end with braces	
																							- Cleaning Option/Scraper: 0 = None 1 = Frame Cut Outs only 2 = Belt Lifters only 3 = Frame Cut Out and Belt Lifters	
																							- Drive Shaft Position: A or D	
																							- Idler Tail Type: 1 = Standard	
																							- Drive Tail Type: 1 = Customer Supplied Motor Standard Tail 2 = Side Drive Standard Tail 3 = Motorized Roller Standard Tail	
																							- Belt Direction: E = Inclining, D = Declining	
																							- Angle: 30 degrees thru 60 degrees in 05 degree increments	
																							- Conveyor L3 Lower Horizontal Section Length (mm): 0610 to 6100 in 5 mm increments (64 - 240 in)	
																							- Conveyor L2 Angled Section Length (mm): 0610 to 6100 in 5 mm increments (24 - 240 in)	
																							- Conveyor L1 Upper Horizontal Section Length (mm): 0610 to 6100 in 5 mm increments (24 - 240 in)	
																							- Conveyor Width Reference (mm): = 0200 to 0600 (7.9 - 23.6 in)	
																							- Documentation Language: M = US English	

* Conveyor load capacity depends on conveyor size, incline, motor position, accumulated loads and other factors.

** Note: Do not run the conveyor with the tail in the tip-up position.

Order gearmotor mounting packages and gearmotors separately, see pages 48-51.
For support stands and accessories, see page 53-56.

LPZ (Z-FRAME) MODULAR CLEATED BELT



SANITARY
OPTIONS



FRAME CUTOUTS



BELT LIFTER



iDRIVE 2
MOTORIZED ROLLER

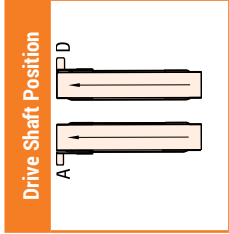
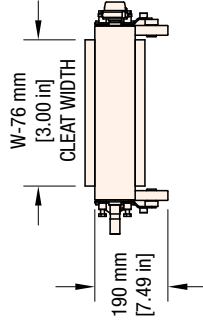
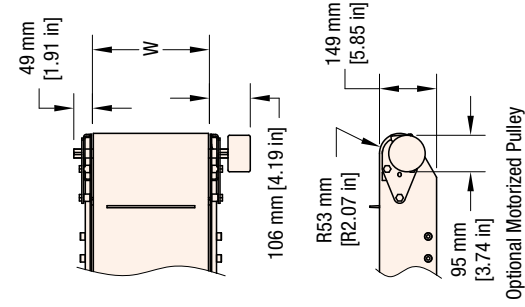

See page 41 for side profile options

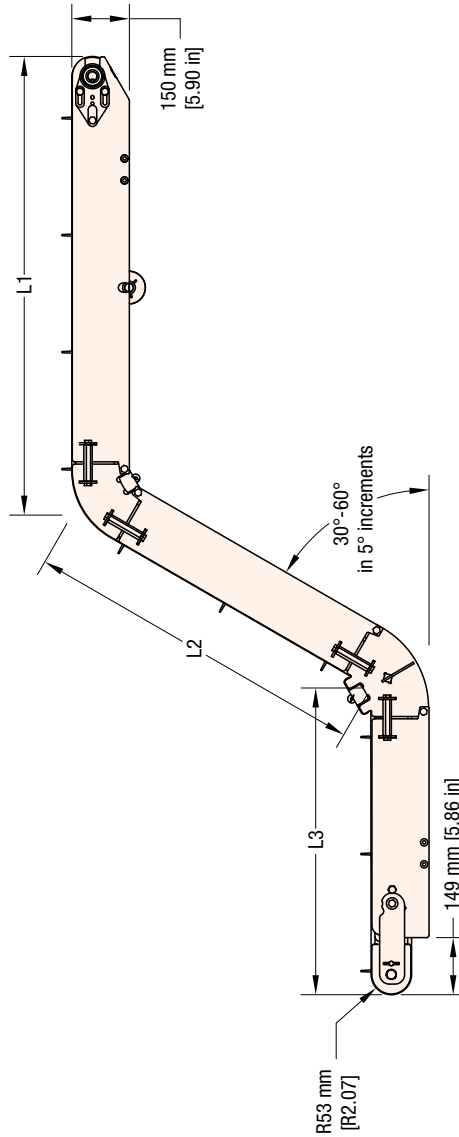
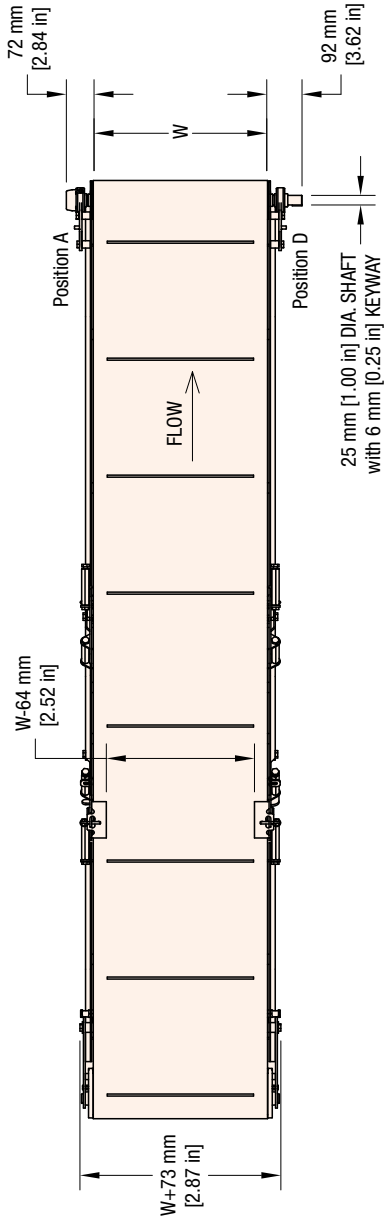

W = Conveyor Belt Width Dim = mm (in)

STANDARD SIZES												
Conveyor Width Reference	200	250	300	350	400	450	500	550	600			
Conveyor Belt Width (W)	200	250	300	350	400	450	500	550	600			
	(7.9)	(9.8)	(11.8)	(13.8)	(15.7)	(17.7)	(19.7)	(21.7)	(23.6)			
Conveyor Length Reference	0610		00005 increments up to...								6100	
Conveyor Length (L)	0610 (24)		00005 (0.2) increments up to...								6100 (240)	

FLAT MODULAR BELT PROFILES

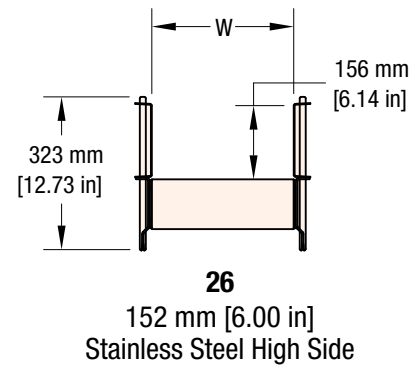
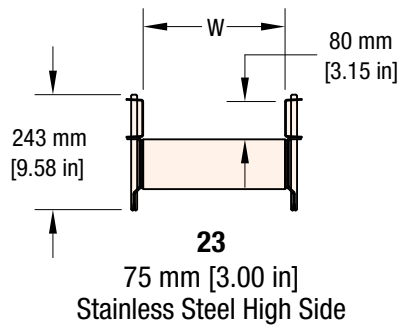
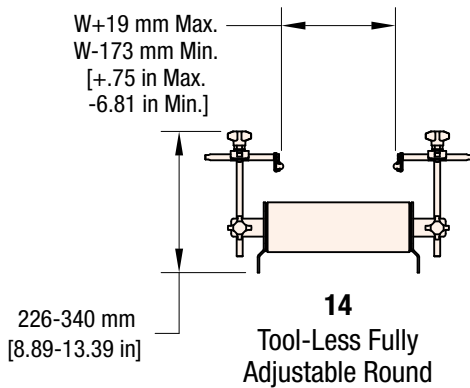
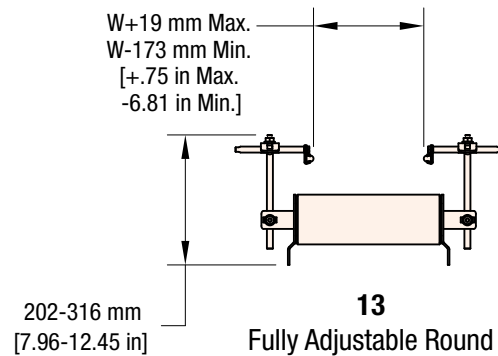
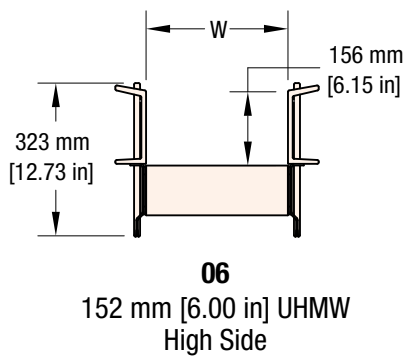
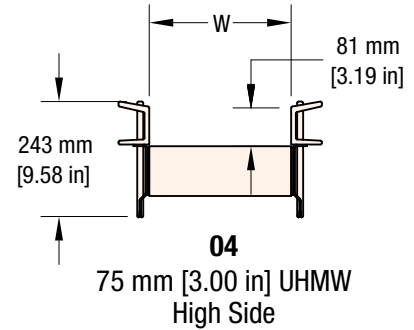
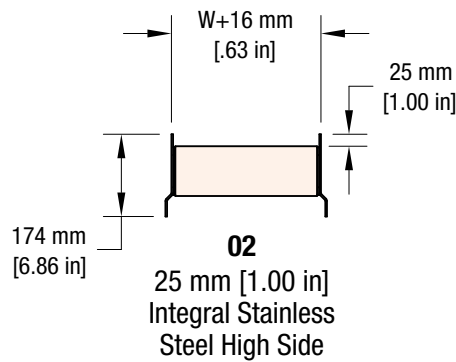
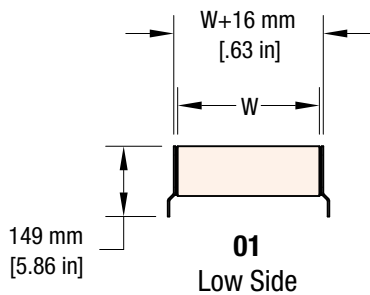

All AquaPruf stainless steel and UHMW guiding profiles are quick removal without tools for fast effective cleaning

W = Conveyor Belt Width Dim = mm (in)

Due to the wide variety of drive set ups and applications, point of installation guarding is the responsibility of the end user.

CLEATED MODULAR BELT PROFILES

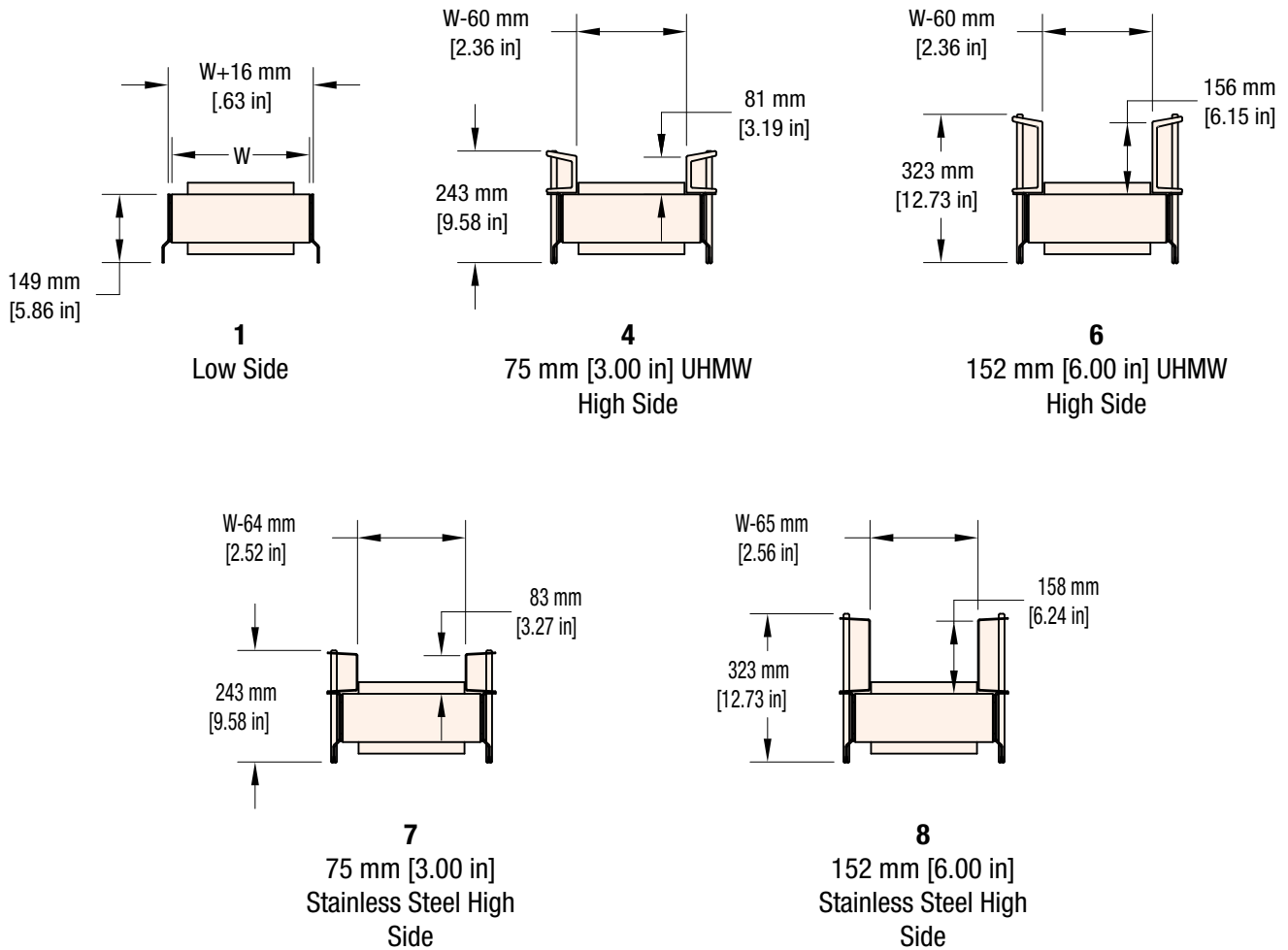

All AquaPruf stainless steel and UHMW guiding profiles are quick removal without tools for fast effective cleaning

W = Conveyor Belt Width Dim = mm (in)

Due to the wide variety of drive set ups and applications, point of installation guarding is the responsibility of the end user.

MODULAR BELT CURVE STRAIGHT PROFILE

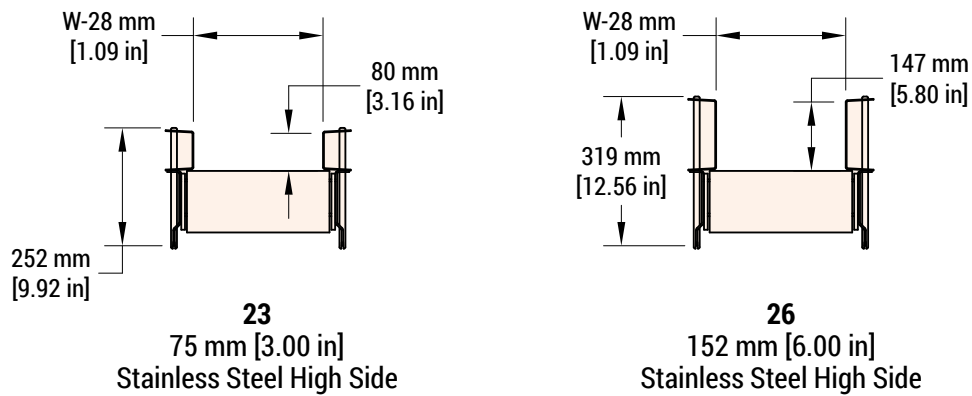
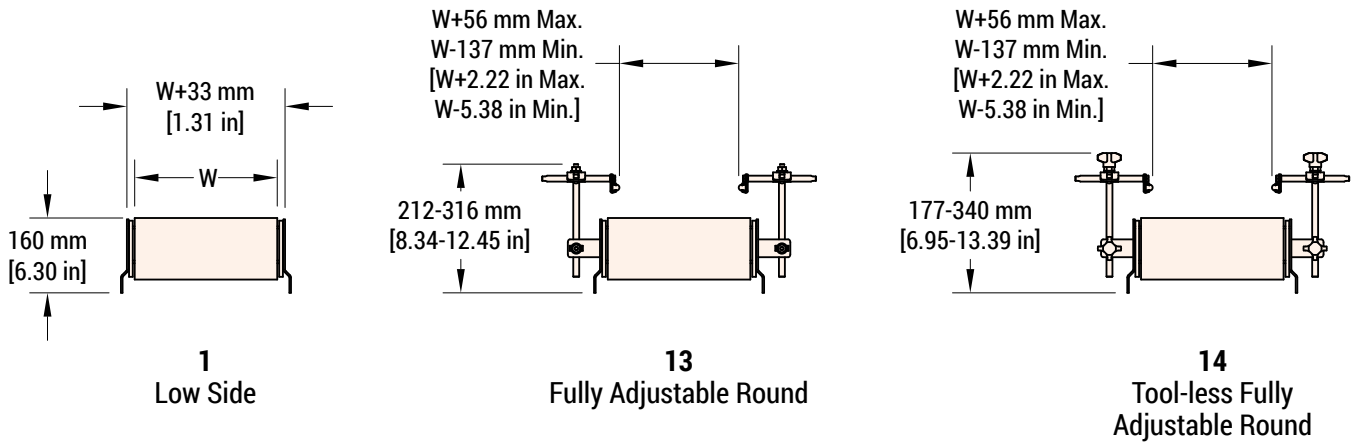

W = Conveyor Belt Width Dim = mm (in)

Due to the wide variety of drive set ups and applications, point of installation guarding is the responsibility of the end user.

MODULAR BELT TYPES



Flat Top Belts

provide a closed surface for complete product support, easy wiping.

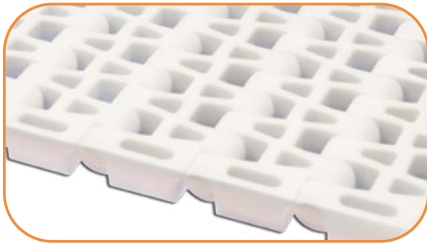

Flush Grid Belts

provide an open surface for better drainage, cleaning or air flow/cooling.



Friction Inserts

are available for incline applications. Inserts may be placed along entire length of the belt or spaced on 51 mm (2 in), 102 mm (4 in), 152 mm (6 in) or 305 mm (12 in) centers. Friction inserts are indented 51 mm (2 in) from each belt edge.

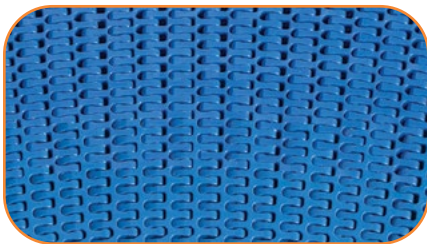

Curve Belts

provide a tight radius, space saving corner. Side tabs ensure positive belt tracking with a flush top design. Stainless bearings reduce friction providing capability of up to (4) corners.



Cleated Belts

provide a sturdy cleat for elevation at steep inclines. Cleats available in 25 mm (1 in) and 76 mm (3 in) heights.

Modular Belt Selection Guide

Belt Type		Part Number Reference	Description mm (in)	% Open	Pitch mm (in)	Belt Thickness mm (in)	Color	Belt Material	Rod Material	Minimum Product Temperature C (F)	Maximum Product Temperature C (F)**	FDA / CFIA Approved*	Chemical Resistance	Wear Resistance	Maximum Incline / Decline (degrees)**	Nose Bar Idler Diameter mm (in)
Straight Flat Belts	Standard Drive & Idler Pulley	MA/BA	Flat top	0	25 (1)	11 (.43)	White/Blue	Acetal	Polyethylene	-40 (-40)	102 (215)	Y	Good	V-Good	5	N/A
		MB/BB	Flat top	0	25 (1)	11 (.43)	White/Blue	Polypropylene	Polypropylene	5 (40)	135 (275)	Y	V-Good	Good	5	N/A
		MC/BC	Flush grid	35	25 (1)	10 (.39)	White/Blue	Acetal	Polypropylene	5 (40)	93 (200)	Y	Good	V-Good	5	N/A
		MD/BD	Flush grid	35	25 (1)	10 (.39)	White/Blue	Polypropylene	Polypropylene	5 (40)	105 (220)	Y	V-Good	Good	5	N/A
	Nose Bar Drive or Nose Bar Idler	MG/BG	Flat top	0	13 (.5)	10 (.39)	White/Blue	Acetal	Nylon	-40 (-40)	93 (200)	Y	Good	Good	5	25 (1)
		MH/BH	Flat top	0	13 (.5)	10 (.39)	White/Blue	Polypropylene	Nylon	5 (40)	105 (220)	Y	V-Good	V-Good	5	25 (1)
		MJ/BJ	Flush grid	25	13 (.5)	10 (.39)	White/Blue	Acetal	Nylon	-40 (-40)	93 (200)	Y	Good	Good	5	25 (1)
		MK/BK	Flush grid	25	13 (.5)	10 (.39)	White/Blue	Polypropylene	Nylon	5 (40)	105 (220)	Y	V-Good	V-Good	5	25 (1)
Cleated Straight Belts	Standard Drive and Idler Pulley	NA	Flat Top w/25 (1) Cleats	0	25 (1)	11 (.43)	White	Acetal	Polyethylene	-40 (-40)	102 (215)	Y	Good	V-Good	60	N/A
		NB	Flat Top w/25 (1) Cleats	0	25 (1)	11 (.43)	White	Polypropylene	Polypropylene	5 (40)	135 (275)	Y	V-Good	Good	60	N/A
		NC	Flat Top w/75 (3) Cleats	0	25 (1)	11 (.43)	White	Acetal	Polyethylene	-40 (-40)	102 (215)	Y	Good	V-Good	60	N/A
		ND	Flat Top w/75 (3) Cleats	0	25 (1)	11 (.43)	White	Polypropylene	Polypropylene	5 (40)	135 (275)	Y	V-Good	Good	60	N/A
		NE	Flush Grid w/25 (1) Cleats	35	25 (1)	10 (.39)	Blue/White†	Acetal	Polypropylene	5 (40)	93 (200)	Y	Good	V-Good	60	N/A
		NF	Flush Grid w/25 (1) Cleats	35	25 (1)	10 (.39)	White	Polypropylene	Polypropylene	5 (40)	105 (220)	Y	V-Good	Good	60	N/A
		NG	Flush Grid w/75 (3) Cleats	35	25 (1)	10 (.39)	Blue/White†	Acetal	Polypropylene	5 (40)	93 (200)	Y	Good	V-Good	60	N/A
		NH	Flush Grid w/75 (3) Cleats	35	25 (1)	10 (.39)	White	Polypropylene	Polypropylene	5 (40)	105 (220)	Y	V-Good	Good	60	N/A
Friction Top Straight Belts	Standard Idler Pulley	See Table Below	Flat top w/friction inserts	0	25 (1)	14 (.55)	White	Polypropylene	Polypropylene	5 (40)	60 (140)	Y	V-Good	Poor	30	N/A
		See Table Below	Flush grid w/friction inserts	35	25 (1)	14 (.55)	White	Polypropylene	Polypropylene	5 (40)	60 (140)	Y	V-Good	Poor	30	N/A
Curved Flat Belts	Standard and Nose Bar Idler Pulley	EA	Plain Chain	0	25 (1)	13 (.51)	Blue	Acetal	Polypropylene	-20 (-4)	60 (140)	Y	Good	V-Good	5	N/A
		EB to EF****	Friction Insert	0	25 (1)	13 (.51)	Blue	Polypropylene	Polypropylene	-20 (-4)	60 (140)	Y	Good	V-Good	30	N/A

* FDA = Food and Drug Administration, CFIA = Canadian Food Inspection Agency

** Temperature, environmental conditions, product materials and product configuration effect the maximum incline or decline. Product testing is recommended.

*** These do not indicate ambient running conditions. Ambient temperature range is -1 to 38 C (30 to 100 F).

Product temperature is dependent on length of time product is in direct contact with belt surface. Product testing is recommended.

**** EB = 25 mm (1 in) spacing; EC = 51 mm (2 in) spacing; ED = 102 mm (4 in) spacing; EE = 152 mm (6 in) spacing; EF = 305 mm (12 in) spacing

†Belt color dependent on belt width selection

FRICITION TOP STRAIGHT PLASTIC CHAIN: Part number reference chart

Flat Top w/ Friction Inserts Part Number Reference	TA	TB	TC	TD	TE
Flush Grid w/ Friction Inserts Part Number Reference	N/A	TF	TG	TH	TJ
Friction Insert Spacing	25 mm (1 in)	51 mm (2 in)	102 mm (4 in)	152 mm (6 in)	305 mm (12 in)

Note: Friction Top not available on nose bar drives

Dorner's AquaPruf Ultimate conveyors are 3-A Certified. These product upgrades ensures that the AquaPruf Ultimate meets the strict requirements of 3-A and is optimally designed for use in food applications such as meat, poultry, fish and ready-to-eat. Conveyor models available in AquaPruf Ultimate 3A are: Straight Modular Flat Belt, Straight Modular Cleated Belt, LPZ Modular Cleated Belt and Positive Drive Belt.



All surfaces on internal frame components are polished to 32 microinch, except belted product.

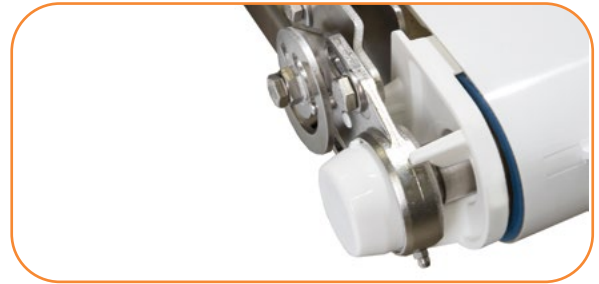

All bearings are external to the conveyor and a minimum of 25 mm away from the food zone.

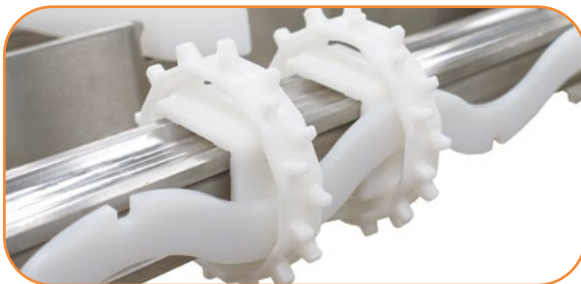

Drive sprocket design includes a quick cleaning system to ensure cleaning can be done below the sprocket surface.



Patent pending idler tail cleaning system on Modular Belt and Positive Drive Belt models.



Belting / Chain offered meet strict 3A and USDA requirements.



All support stands use only sanitary threadless feet designs.



Radii on all internal components meet the 6 mm (0.25 in) standard requirement.



Conveyor cleaning guideline is provided specifically for effective cleaning of the Dorner product.

IDRIVE2 MOTORIZED ROLLER



Belt Speed																					
Width		RPM		Belt Speed												Peak Motor Torque		Amps		Belt Pull	
				Belted Conveyor				Modular Belt				Positive Drive Belt									
				m/min		ft/min		m/min		ft/min		m/min		ft/min							
(mm)	(inch)	Min	Max	Min	Max	Min	Max	Min	Max	Min	Max	Min	Max	Min	Max	Nm	in-lbs	FLA	N	lbs	
203	8	20	250	5.6	69.8	18	229	6.2	77.4	20	254	6.2	77.7	20	255	7	62	2.6	41*	9*	
254	10	20	250	5.6	69.8	18	229	6.2	77.4	20	254	6.2	77.7	20	255	10	89	2.4	74*	17*	
305	12	20	250	5.6	69.8	18	229	6.2	77.4	20	254	6.2	77.7	20	255	15	133	2.4	165	37	
356	14	20	250	5.6	69.8	18	229	6.2	77.4	20	254	6.2	77.7	20	255	15	133	2.8	165	37	
406	16	20	250	5.6	69.8	18	229	6.2	77.4	20	254	6.2	77.7	20	255	20	177	2.4	220	50	
457	18	20	250	5.6	69.8	18	229	6.2	77.4	20	254	6.2	77.7	20	255	25	221	2.6	275	62	
508	20	20	250	5.6	69.8	18	229	6.2	77.4	20	254	6.2	77.7	20	255	25	221	2.6	275	62	
559	22	20	250	5.6	69.8	18	229	6.2	77.4	20	254	6.2	77.7	20	255	30	266	5.4	330	74	
610	24	20	250	5.6	69.8	18	229	6.2	77.4	20	254	6.2	77.7	20	255	30	266	5.4	330	74	
660	26	20	250	5.6	69.8	18	229	6.2	77.4	20	254	6.2	77.7	20	255	30	266	5.4	330	74	
711	28	20	250	5.6	69.8	18	229	6.2	77.4	20	254	6.2	77.7	20	255	30	266	5.4	330	74	
762	30	20	250	5.6	69.8	18	229	6.2	77.4	20	254	6.2	77.7	20	255	40	354	5.0	440	99	
813	32	20	250	5.6	69.8	18	229	6.2	77.4	20	254	6.2	77.7	20	255	40	354	5.0	440	99	
864	34	20	250	5.6	69.8	18	229	6.2	77.4	20	254	6.2	77.7	20	255	40	354	5.0	440	99	
914	36	20	250	5.6	69.8	18	229	6.2	77.4	20	254	6.2	77.7	20	255	40	354	5.0	440	99	
965	38	20	250	5.6	69.8	18	229	6.2	77.4	20	254	6.2	77.7	20	255	40	354	5.0	440	99	
1016	40	20	250	5.6	69.8	18	229	6.2	77.4	20	254	6.2	77.7	20	255	40	354	5.0	440	99	
1067	42	20	250	5.6	69.8	18	229	6.2	77.4	20	254	6.2	77.7	20	255	40	354	5.0	440	99	
1118	44	20	250	5.6	69.8	18	229	6.2	77.4	20	254	6.2	77.7	20	255	40	354	5.0	440	99	
1168	46	20	250	5.6	69.8	18	229	6.2	77.4	20	254	6.2	77.7	20	255	40	354	5.0	440	99	
1219	48	20	250	5.6	69.8	18	229	6.2	77.4	20	254	6.2	77.7	20	255	40	354	5.0	440	99	

*Sub 15Nm peak motor torque cases have reduced belt pull to compensate for overcoming seal pressure.

GEARMOTOR MOUNTING PACKAGE & GEARMOTOR SELECTION STEPS

- Step 1:** Use the **Belt Speed Chart** (page 48) to determine your desired belt speed based on conveyor type and mount package. See Gearmotor column.
- Step 2:** Locate the appropriate gearmotor chart (pages 49-50) in terms of **Painted** vs. **Stainless Steel** based on your gearmotor chart numbers

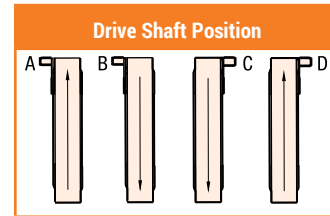

Side Mount Package, 90° Gearmotor

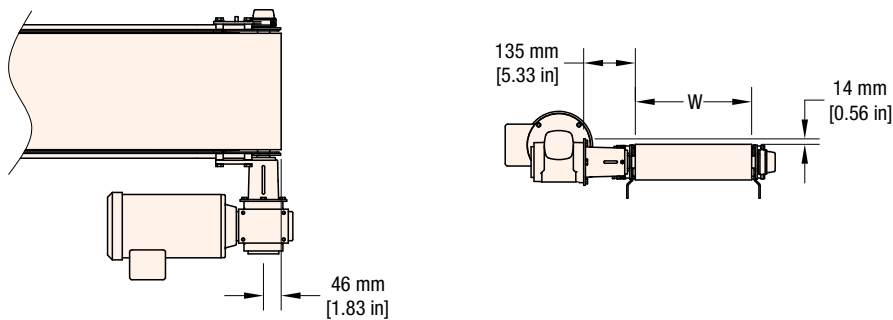

- Includes stainless steel gearmotor bracket, coupling and mounting hardware

W = Conveyor Belt Width

90° Gearmotor Location Options

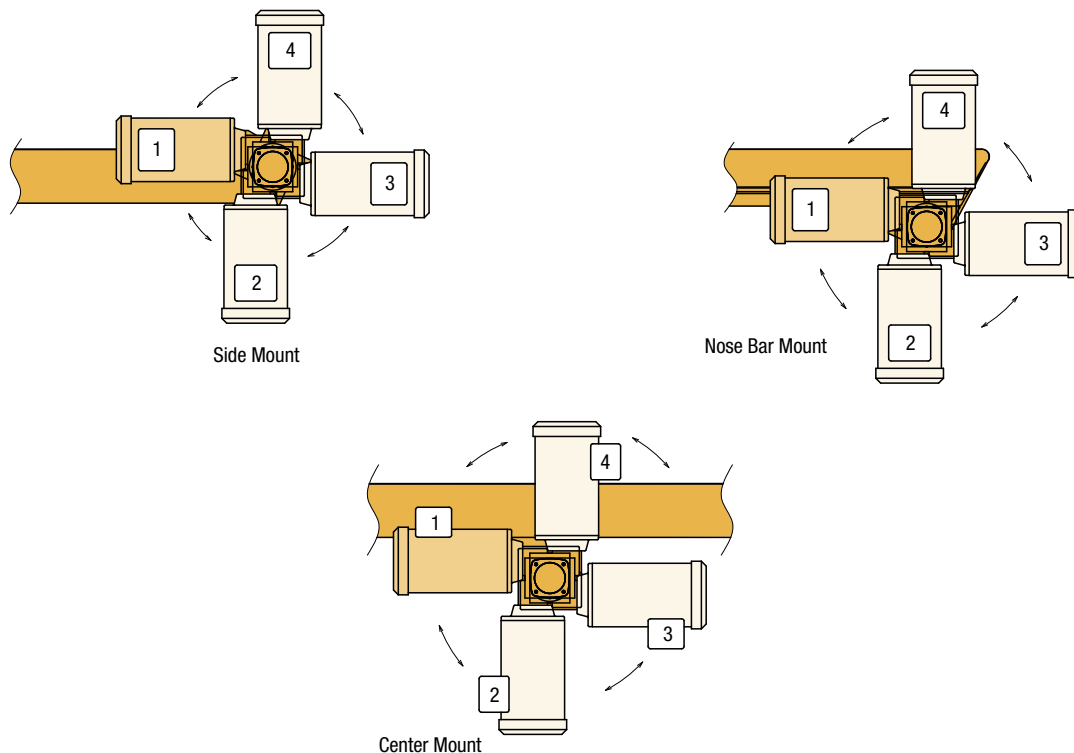

Due to the wide variety of drive set ups and applications, point of installation guarding is the responsibility of the end user.

Note: Conveyor and gearmotor are not included in the mounting package and must be ordered separately. Dimensions = in (mm)

Nose Bar Mount Package, 90° Gearmotor

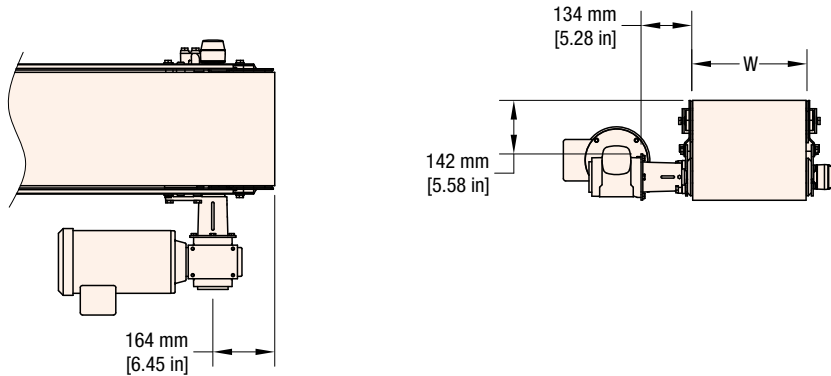

- Includes stainless steel gearmotor mounting bracket and mounting hardware

W = Conveyor Belt Width

Gearmotor Mount Packages

7	4	Z	B	S	H	S	A
- Drive Position: A, B, C or D - Gearmotor Size: S = Standard Load - Gearmotor Type: H = 90° - Motor Material: S = Stainless P = Painted - Motor Orientation: 1 = Back (Standard) 2 = Up 3 = Forward 4 = Down - Language: Z = Universal							

Fixed Speed

Belt Speed						RPM From Gearmotor	Gearmotor Chart
Belted Conveyor		Modular Belt		Positive Drive Belt			
m/min	ft/min	m/min	ft/min	m/min	ft/min		
8	26	9	30	9	30	29	1,2
12	39	14	46	14	46	44	1,2
16	52	18	59	18	59	58	1,2
24	79	27	89	27	89	87	1,2
33	108	36	118	36	118	117	1,2
49	161	54	177	54	177	175	1,2
65	213	72	236	72	236	233	1,2

Variable Speed

Belt Speed						RPM at 60Hz Gearmotor	Gearmotor Chart
Belted Conveyor		Modular Belt		Positive Drive Belt			
m/min	ft/min	m/min	ft/min	m/min	ft/min		
1 to 8	3 to 26	1 to 9	3 to 30	1 to 9	3 to 30	29	3,4
1 to 12	4 to 39	1 to 14	5 to 46	1 to 14	5 to 46	44	3,4
2 to 16	5 to 52	2 to 18	6 to 59	2 to 18	6 to 59	58	3,4
2 to 24	8 to 79	3 to 27	9 to 89	3 to 27	9 to 89	87	3,4
3 to 33	11 to 108	4 to 36	12 to 118	4 to 36	12 to 118	117	3,4
5 to 49	16 to 161	5 to 54	18 to 177	5 to 54	18 to 177	175	3,4
7 to 65	21 to 213	7 to 72	24 to 236	7 to 72	24 to 236	233	3,4

Due to the wide variety of drive set ups and applications, point of installation guarding is the responsibility of the end user.

Fixed Speed

Chart 1 Painted Steel

- Nema 56C
- IP65 Protection Rating
- Sealed Gearmotor with H1 FDA approved Lubricant
- FDA approved white epoxy painted motor
- Aluminum gearbox with sanitary coating
- Totally enclosed non-ventilated motor (0.5 HP)
- Totally enclosed fan cooled motor (1 and 1.5 HP)
- 3 Phase, 60 Hz

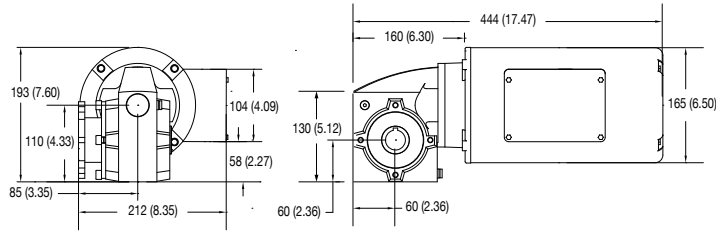

Regulatory Approvals



Part Number	RPM	Hp	kW	Volts	FLA	in. - lbs.	Nm
71M060HS423FN	29	0.5	0.37	230/460	1.6/0.8	442	50
71M040HS423FN	44	0.5	0.37	230/460	1.6/0.8	486	55
71M030HS423FN	58	1	0.74	208-230/460	3.5-3.2/1.6	487	55
71M020HS423FN	87	1	0.74	208-230/460	3.5-3.2/1.6	407	46
71M015HS423FN	117	1	0.74	208-230/460	3.5-3.2/1.6	470	53
71M010HS423FN*	175	1.5	1.11	208-230/460	4.6-4.2/2.1	442	50
71M007HS423FN**	233	1.5	1.11	208-230/460	4.6-4.2/2.1	362	41

Chart 2 Stainless Steel

- Nema 56C
- IP65 Protection Rating
- Sealed Gearmotor with H1 FDA approved Lubricant
- Stainless Steel motor
- Stainless Steel gearbox
- Totally enclosed non-ventilated motor (0.5 HP)
- Totally enclosed fan cooled motor (1 and 1.5 HP)
- 3 Phase, 60 Hz

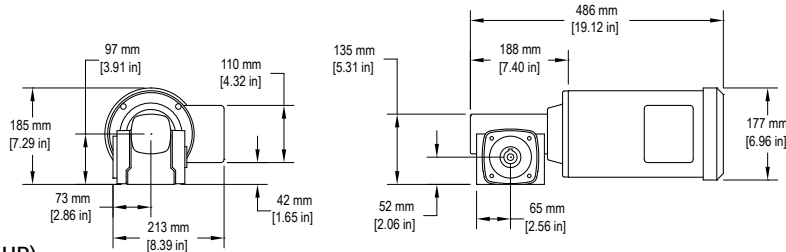

Regulatory Approvals



Part Number	RPM	Hp	kW	Volts	FLA	in. - lbs.	Nm
76M060HZS423FN	29	0.5	0.37	230/460	1.6/0.8	442	50
76M040HZS423FN	44	0.5	0.37	230/460	1.6/0.8	486	55
76M030HZS423FN	58	1	0.74	208-230/460	3.5-3.2/1.6	487	55
76M020HZS423FN	87	1	0.74	208-230/460	3.5-3.2/1.6	407	46
76M015HZS423FN	117	1	0.74	208-230/460	3.5-3.2/1.6	470	53
76M010HZS423FN*	175	1.5	1.11	208-230/460	4.6-4.2/2.1	442	50
76M007HZS423FN**	233	1.5	1.11	208-230/460	4.6-4.2/2.1	362	41

HIGHLIGHT

*Gearmotor not available for Ø 12.7 mm (Ø0.5 in.) nose bar idler tail option,
 **Gearmotor not available for any Ø nose bar idler tail options.
NOSE BAR MAX RATED SPEEDS:
 Max speed of Ø12.7 mm (Ø0.5 in.) nose bar idler tail is 117 rpm which equates to belted speed of 33 m/min (108 fpm).
 Max speed of Ø32 mm (Ø1.25 in.) nose bar idler tail is 175 rpm which equates to belted speed of 49 m/min (161 fpm).
 Max speed of Ø48 mm (Ø1.88 in.) nose bar idler tail is 175 rpm which equates to belted speed of 49 m/min (161 fpm).

CE Note: When buying a gearmotor only without the starter, the customer must supply their own on/off switch and motor overload protection to comply with the CE Safety Directive.

FLA = Full Load Amperes Some motors and gear reducers may normally operate hot to the touch. Consult factory for specific operating temperatures. **Note:** Dimensions = mm (in)

Variable Speed

Chart 3		Painted Steel						Regulatory Approvals
<ul style="list-style-type: none"> • Nema 56C • IP65 Protection Rating • Sealed Gearmotor with H1 FDA approved Lubricant • FDA approved white epoxy painted motor • Aluminum gearbox with sanitary coating • Totally enclosed non-ventilated motor (0.5 HP) • Totally enclosed fan cooled motor (1 and 1.5 HP) • 3 Phase, 6 to 60 Hz • Order controller separately 								
Part Number	RPM	Hp	kW	Volts	FLA	in. - lbs.	Nm	
71M060HS423EN	29	0.5	0.37	230/460	1.6/0.8	442	50	
71M040HS423EN	44	0.5	0.37	230/460	1.6/0.8	486	55	
71M030HS423EN	58	1	0.74	208-230/460	3.5-3.2/1.6	487	55	
71M020HS423EN	87	1	0.74	208-230/460	3.5-3.2/1.6	407	46	
71M015HS423EN	117	1	0.74	208-230/460	3.5-3.2/1.6	470	53	
71M010HS423EN*	175	1.5	1.11	208-230/460	4.6-4.2/2.1	442	50	
71M007HS423EN**	233	1.5	1.11	208-230/460	4.6-4.2/2.1	362	41	

Chart 4		Stainless Steel						Regulatory Approvals
<ul style="list-style-type: none"> • Nema 56C • IP65 Protection Rating • Sealed Gearmotor with H1 FDA approved Lubricant • Stainless Steel motor • Stainless Steel gearbox • Totally enclosed non-ventilated motor (0.5 HP) • Totally enclosed fan cooled motor (1 and 1.5 HP) • 3 Phase, 6 to 60 Hz • Order controller separately 								
Part Number	RPM	Hp	kW	Volts	FLA	in. - lbs.	Nm	
76M060HZZS423EN	29	0.5	0.37	230/460	1.6/0.8	442	50	
76M040HZZS423EN	44	0.5	0.37	230/460	1.6/0.8	486	55	
76M030HZZS423EN	58	1	0.74	208-230/460	3.5-3.2/1.6	487	55	
76M020HZZS423EN	87	1	0.74	208-230/460	3.5-3.2/1.6	407	46	
76M015HZZS423EN	117	1	0.74	208-230/460	3.5-3.2/1.6	470	53	
76M010HZZS423EN*	175	1.5	1.11	208-230/460	4.6-4.2/2.1	442	50	
76M007HZZS423EN**	233	1.5	1.11	208-230/460	4.6-4.2/2.1	362	41	

HIGHLIGHT	<p>*Gearmotor not available for Ø 12.7 mm (Ø-0.5 in.) nose bar idler tail option, **Gearmotor not available for any Ø nose bar idler tail options.</p> <p>NOSE BAR MAX RATED SPEEDS: Max speed of Ø12.7 mm (Ø0.5 in.) nose bar idler tail is 117 rpm which equates to belted speed of 33 m/min (108 fpm). Max speed of Ø32 mm (Ø1.25 in.) nose bar idler tail is 175 rpm which equates to belted speed of 49 m/min (161 fpm). Max speed of Ø48 mm (Ø1.88 in.) nose bar idler tail is 175 rpm which equates to belted speed of 49 m/min (161 fpm).</p>
------------------	--

CE Note: When buying a gearmotor only without the starter, the customer must supply their own on/off switch and motor overload protection to comply with the CE Safety Directive.

FLA = Full Load Amperes Some motors and gear reducers may normally operate hot to the touch. Consult factory for specific operating temperatures. **Note:** Dimensions = mm (in)

Variable Speed Controllers

Chart A



Variable Speed Controllers

- Variable Frequency Drive
- IP 65 Plastic Enclosure
- Stainless Steel mounting hardware
- Digital Display
- Keypad with Start/Stop and Speed variation
- Includes cord to motor
- Power to controller by others
- UL Approved

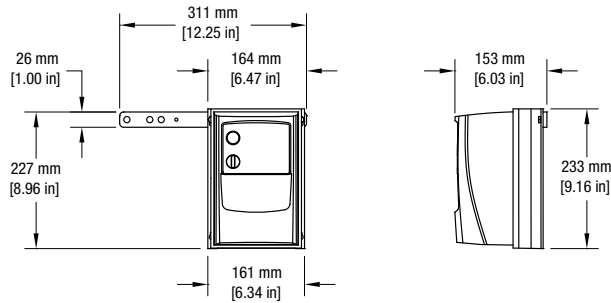

Part Number	Input			Output		Max Hp	Max Amps
	Volts	Phase	Hz	Volts	Phase		
76MVA1122S	115	1	60	230	3	0.5	2.3
76MVA2122S	230	1	60	230	3	0.5	2.3
76MVA2322S	230	3	60	230	3	0.5	2.3
76MVA4342S	460	3	60	460	3	0.5	1.2
76MVA1121S	115	1	60	230	3	1	4.3
76MVA2121S	230	1	60	230	3	1	4.3
76MVA2321S	230	3	60	230	3	1	4.3
76MVA4341S	460	3	60	460	3	1	2.2
76MVA2127S	230	1	60	230	3	2	7
76MVA2327S	230	3	60	230	3	2	7
76MVA4347S	460	3	60	460	3	2	4.1

MANUAL MOTOR STARTER

Chart B



Manual Motor Starter

- Nema 4X Plastic Enclosure
- Stainless Steel mounting hardware
- IP 66
- Start / Stop Switch
- Lock-out tag-out capable
- Includes wiring to Motor
- Power to Starter by others
- No plug/cord set included

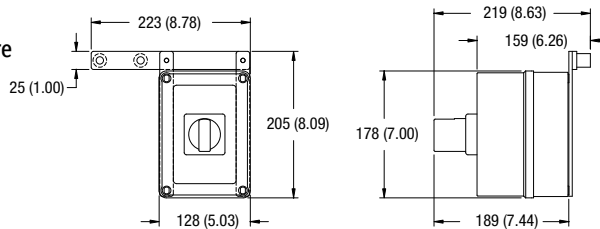

Part Number	Input			FLA
	Volts	Phase	Hz	
74MM11F	115	1	60	6.3 - 10
74MM21D	208-230	1	60	2.5 - 3.9
74MM23A	208-230	3	60	0.63 - 0.99
74MM23B	208-230	3	60	1.0 - 1.59
74MM23C	208-230	3	60	1.6 - 2.4
74MM23D	208-230	3	60	2.5 - 3.9
74MM23E	208-230	3	60	4.0 - 6.3
74MM43A	460	3	60	1.6 - 2.4
74MM43B	460	3	60	2.5 - 3.9
74MM43C	460	3	60	0.63 - 0.99
74MM43D	460	3	60	1.0 - 1.59

FLA = Full Load Amperes

Fixed Height Stands

- Welded open frame Stainless Steel construction with a Brushed #4 finish
- Fixed angle connection matching conveyor layout from 0° to 60 degrees
- For 152 mm (6 in) to 1219 mm (48 in) widths
- ± 51 mm (2 in) of adjustment
- Optional swivel locking caster
- Optional diagonal brace for added stability
- Optional 3-A approved threadless foot and casters
- For available heights see page 55



OPTIONAL:
3-A approved Thread-less Foot



OPTIONAL:
Swivel Caster



OPTIONAL: Diagonal Brace

Outriggers

- Fixed height support stands are available with outriggers
- Outriggers provide added support for tall applications
- Welded Stainless Steel construction with Brushed #4 finish
- Extend stand width 316 mm (12.43 in)



Dimensions = mm (in)

Note: Due to the wide variety of conveyor and stand options along with possible configurations, stability of the final setup is the responsibility of the end user.

Tall Supports Stands

- Welded open frame Stainless Steel construction brushed to #4 finish
- ±50 mm (2 in) of adjustment
- Fixed angle connection matching conveyor layout from 0° to 60 degrees
- Includes diagonal brace for stability
- Tall Support Stands require the use of floor anchors
- For available heights see page 55



**OPTIONAL:
3-A Approved Thread-less Foot**



Tall Stand

Low Height Supports Stands

- All components are Stainless Steel brushed to #4 finish
- ±51 mm (2 in) of adjustment
- Fixed Foot self-aligns 10° for sloped floors
- Caster is swivel locking
- Horizontal conveyor mounts only
- Optional 3-A approved threadless foot and casters
- For available heights see page 55

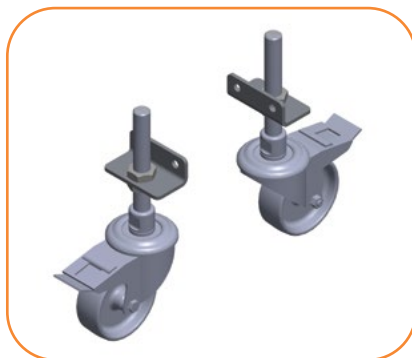

**Swivel Locking
Caster Model**

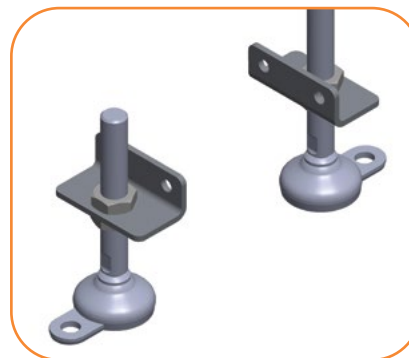

Fixed Foot Model

Dimensions = mm (in)

Note: Due to the wide variety of conveyor and stand options along with possible configurations, stability of the final setup is the responsibility of the end user.

Support Stand Heights																								
Type	Fixed Foot								Hygenic Thread-less Foot Foot								Caster Foot							
	Shortest Stand				Tallest Stand				Shortest Stand				Tallest Stand				Shortest Stand			Tallest Stand				
	Minimum Top Of Belt		Maximum Top Of Belt		Minimum Top Of Belt		Maximum Top Of Belt		Minimum Top Of Belt		Maximum Top Of Belt		Minimum Top Of Belt		Maximum Top Of Belt		Minimum Top Of Belt		Maximum Top Of Belt		Minimum Top Of Belt	Maximum Top Of Belt		
	mm	in	mm	in	mm	in	mm	in	mm	in	mm	in	mm	in	mm	in	mm	in	mm	in	mm	in	mm	in
Fixed Height	275	10.8	375	14.8	1900	74.8	2000	78.7	275	10.8	325	12.8	1900	74.8	1950	76.8	400	15.7	500	19.7	2000	78.7	2100	82.7
Tall Support	1850	72.8	1950	76.8	2400	94.5	2500	98.4	1850	72.8	1900	74.8	2400	94.5	2450	96.5	N/A		N/A		N/A		N/A	
Short Height	200	7.9	300	11.8	N/A		N/A		N/A		N/A		N/A		N/A		325	12.8	425	16.7	N/A		N/A	

Height increments of 25 mm (1 in)
 Top of belt heights for Modular Belt Curve are 25 mm shorter

Fixed Height Support Stands Widths*																							
Conveyor Width	152	203	254	305	356	406	457	508	559	610	660	711	762	813	864	914	965	1016	1067	1118	1168	1219	
Conveyor Belt Width (W)	mm	152	203	254	305	356	406	457	508	559	610	660	711	762	813	864	914	965	1016	1067	1118	1168	1219
	in	6	8	10	12	14	16	18	20	22	24	26	28	30	32	34	36	38	40	42	44	46	48
Stand width	mm	321	372	423	474	525	575	626	677	728	779	829	880	931	982	1033	1083	1134	1185	1236	1287	1337	1388
	in	12.6	14.6	16.7	18.7	20.7	22.6	24.6	26.7	28.7	30.7	32.6	34.6	36.7	38.7	40.7	42.6	44.6	46.7	48.7	50.7	52.6	54.6

*Dimensions shown are nominal. Contact factory for specific layout and dimensions.
 *Contact factory for Tall and Low Height Support Stand configurations.

AquaPruf Support Stands

7 4 H Z WWW - HHH HHH B S T T F A A

- **Angle:** Blank if Horizontal AA = angle (degrees 01 to 60)
- **Foot:** F = Fixed Foot
 T = Hygenic Thread-less Leveling Feet
 H = Hygenic Thread-less Leveling Feet with Brace
 B = Fixed Foot with Brace (brace not on low height stands)
 C = Caster with Brace (brace not on low height stands)
- **Stand Type:** HM = Horizontal Mount HR = Horizontal Mount with Outrigger
 AM = Angle Mount AR = Angle Mount with Outriggers
 TH = Tall Horizontal Mount TA = Tall Angle Mount
 VM = Variable Angle Mount (0-60 degrees)
 VR = Variable Angle Mount with Outrigger (0-60 degrees)
 LH = Low Height Mount (horizontal only)
- **Configuration:** S = Straight C = Curve / Posi Drive
- **Belt/Chain:** B = Belt C = Chain (Modular Belt) / Posi Drive
- **Maximum Top of Belt Height** = 0100 mm (4 in) more than minimum
- **Minimum Top of Belt Height** = 0200 to 2400 in 25 mm increments (8 - 94 in)
- **Width (mm):** WWW = 0000 for LH (low height) stand type - width independent
- **Language:** Z = Universal
- **Type:** H = H Type Support Stand

Dimensions = mm (in)

Note: Due to the wide variety of conveyor and stand options along with possible configurations, stability of the final setup is the responsibility of the end user.

Horizontal Ceiling Supports

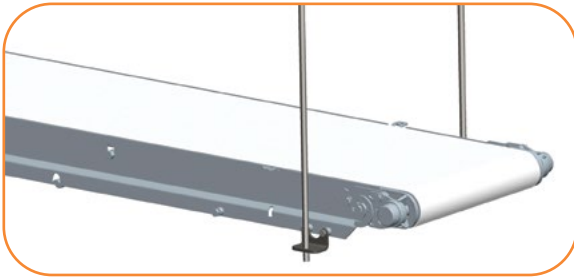

Specifications

- All components are Stainless Steel brushed to #4 finish
- Includes a pair of mounting brackets and hardware for support on both sides of conveyor
- Compatible with 12 mm (0.5 in) threaded support rod (not provided)

Part Number	3UHCS
-------------	-------

Adjustable Angle Ceiling Supports

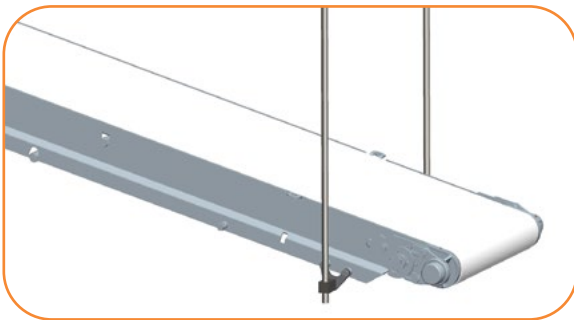

Specifications

- All components are Stainless Steel brushed to #4 finish
- Includes a pair of mounting brackets and hardware for support on both sides of conveyor
- Compatible with 12 mm (0.5 in) threaded support rod (not provided)
- Mounting block pivots to support incline mounts from 0° to 60°

Part Number	3UACS
-------------	-------

Sanitary Floor Anchor Kits - Type 1

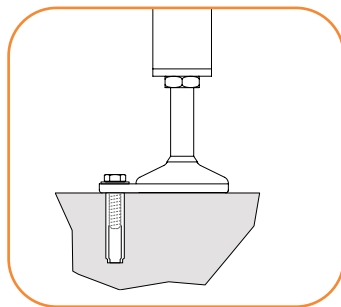

Specifications

- 10 mm (.375 in) x 40 mm (1.57 in) drop in
- Stainless Steel
- Anchor is flush with floor upon removal of bolt
- Two (2) per anchor kit

Part Number	FAS-1
-------------	-------

Sanitary Floor Anchor Kits - Type 2

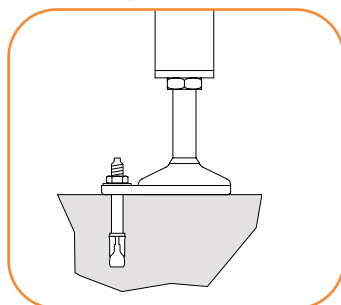

Specifications

- 10 mm (.375 in) x 70 mm (2.75 in)
- Stainless Steel
- Threaded anchor bolt protrudes above floor after installation
- Two (2) per anchor kit

Part Number	FAS-2
-------------	-------

Dimensions = mm (in)

Note: Due to the wide variety of conveyor and stand options along with possible configurations, stability of the final setup is the responsibility of the end user.

Drip Pans



Specifications

- Widths: 152 mm (6 in) to 1524 mm (60 in) available in 50 mm (2 in) increments
- Lengths: 610 mm (24 in) to 25375 mm (999 in) available in 25 mm (1 in) increments maximum section lengths of 2997 mm (118 in)
- Tool-less hook design for fast removal and rapid cleaning
- Provides a 50 mm (2 in) window for clean-out access without removal
- All pans equipped with a 25 mm (1 in) containment lip on all sides
- Contact factory for additional options and ordering

Dimensions = mm (in)

Note: Due to the wide variety of conveyor and stand options along with possible configurations, stability of the final setup is the responsibility of the end user.

Regulatory Approvals:







Conveyors:

All Dorner AquaPruf standard conveyors (not including gearmotors and controllers) are CE approved. CE approval follows the provisions of the following directives; Machine Directive 2006/42/EC, EU Low Voltage Directive 2006/95/EC, and EMC Directive 2004/108/EC. All conveyors are marked with the CE symbol on the Dorner serial number tag located on the conveyor frame. Contact the factory for the CE Declaration of Conformity.

All Dorner AquaPruf standard conveyors (not including gearmotors and controllers) are designed and manufactured in accordance with the restrictions defined in the "Restriction of Hazardous Substances" directive, citation 2002/95/EC, commonly known as RoHS. All conveyors are marked with the RoHS symbols on the Dorner serial number tag located on the conveyor frame.

Gearmotors and Controllers:

All Dorner AquaPruf gearmotors and controllers carry one or more of the following approvals. Products are not covered by each approval. Please see the appropriate part number on the Gearmotor and controller charts located in this manual. In addition, regulatory symbols are located on the product information tags located on the product.

	<p>CE Marking on a product is a manufacturer's declaration that the product complies with the essential requirements of the relevant European health, safety and environmental protection legislation, in practice by the Product Directives. CE Marking on a product ensures the free movement of the product within the European Union (EU).</p>
	<p>This directive restricts (with exceptions) the use of six hazardous materials in the manufacture of various types of electronic and electrical equipment. It is closely linked with the Waste Electrical and Electronic Equipment Directive (WEEE) 2002/96/EC which sets collection, recycling and recovery targets for electrical goods and is part of a legislative initiative to solve the problem of huge amounts of toxic e-waste.</p>
	<p>The UL Recognized Component mark is for products intended to be installed in another device, system or end product. This Recognized Component Mark is for the United States only. When a complete product or system containing UL Recognized Components is evaluated, the end-product evaluation process can be streamlined.</p>
	<p>The UL Recognized Component mark is for products intended to be installed in another device, system or end product. This Recognized Component Mark is for the United States and Canada. When a complete product or system containing UL Recognized Components is evaluated, the end-product evaluation process can be streamlined.</p>
	<p>CSA International (Canadian Standards Association), is a provider of product testing and certification services for electrical, mechanical, plumbing, gas and a variety of other products. Recognized in the U.S., Canada and around the world, CSA certification marks indicate that a product, process or service has been tested to a Canadian or U.S. standard and it meets the requirements of an applicable CSA standard or another recognized document used as a basis for certification.</p>
	<p>The UL Listing Mark means UL found that representative product samples met UL's safety requirements. These requirements are primarily based on UL's own published standards for safety. The C-UL-US Mark indicates compliance with both Canadian and U.S. requirements. The products with this type of Mark have been evaluated to Canadian safety requirements and U.S. safety requirements.</p>

Baking Industry Standards and Certifications:

AquaPruf Belted and Modular Conveyors are often used in food production or food packaging areas where proper design of equipment is essential to maintain proper food safety. AquaPruf conveyors are designed for wash down environments typically seen in ready-to-eat, meat, poultry, or dairy production. In these applications the correct installation and application of the conveyor is critical to the proper running of the conveyor and maintaining proper food safety. The end user must ensure that the conveyor belts are properly tracked and the conveyor is properly installed as defined by Dorner.

All AquaPruf products are designed and constructed to be used in food production environments. Dorner Mfg Corp attests that the following AquaPruf conveyors conform to the ANSI/ASB/Z50.2-2015 (R2020) standard through Bakery Equipment Assessment Group (BEAGROUP.ORG)

AquaPruf Belted Conveyors
AquaPruf Positive Drive Belt Conveyors
AquaPruf Modular Belt Conveyors



Contact the factory for copy of the certification.

3-A Sanitary Standard Certification:

For 3-A compliance, a conveyor cover or shield must be installed over the conveyor that is easily cleaned, self-draining, and located to prevent liquid or other contaminants from draining or dropping into the container or product, or onto the conveyor belt. Multiple covers can be used if necessary, with overlapping edges. Cover(s) should be fabricated from stainless steel or FDAcertified plastic material, and the bottom of the cover(s) must be smooth, with no crevices or exposed threads.

The following AquaPruf Ultimate Conveyors have gone through testing and certification to 3-A standard for mechanical conveyors, 41-03.

AquaPruf Ultimate Positive Drive Belt Conveyors
AquaPruf Ultimate Modular Belt Conveyors with belts, MA, MB, BA, BB, NA, NB, NC, and ND

Contact the factory for copy of the certification.

Materials and Chemical Resistance:

Conveyor Frames, Plastics and Modular Belting	
The following is a list of base materials used in the 7350 Series conveyor:	
Material	Conveyor Component
Acetal Copolymer, POM	Modular Belts, molded bearing housings
Polypropylene, PP	Modular Belts
Polyamide, PA	Adjustable Guide Support Brackets
UHMW-PE	Modular Belt Slide Rail, Adjustable Guide Face
Thermoplastic Elastomer, TPE	Modular Belt Friction Insert

The materials used in the AquaPruf product can resist many chemicals, however some should be avoided. Avoid the following:

- Acids with PH less than 4
- Bases with PH higher than 9

Resistance to Materials: Conveyor Frames, Plastics and Modular Belting				
The following table provides the resistance to materials used in the conveyor to several chemicals. Application testing is recommended to determine long term material durability.				
Legend:				
1 = Very good resistance 2 = Good resistance 3 = Moderate resistance 4 = Not recommended X = no data available				
Acids	Acetal POM	Polypropylene	Polyamide PA	UHMW-PE
Acetic acid	3	1	4	1
Benzoic acid	3	1	4	1
Boric acid	3	1	2	1
Citric acid	3	1	2	1
Chromic acid	4	1	4	1
Hydrofluoric acid	4	1	4	1
Hydrochloric acid	4	1	4	1
Hydro cyanic acid	4	X	4	1
Nitric acid	4	1	4	1
Oleic acid	3	1	2	1
Oxalic acid	4	1	2	1
Phosphoric acid	4	1	4	1
Sulphuric acid	4	2	4	1
Tartaric acid	3	1	2	1
Basic Compounds	Acetal POM	Polypropylene	Polyamide PA	UHMW-PE
Ammonia	1	1	2	1
Calcium hydroxide	1	X	2	1
Caustic soda	1	X	2	1
Potassium hydroxide	1	1	2	1

Resistance to Materials: Conveyor Frames, Plastics and Modular Belting <i>(continued)</i>				
Legend: 1 = Very good resistance 2 = Good resistance 3 = Moderate resistance 4 = Not recommended X = no data available				
Salts	Acetal POM	Polypropylene	Polyamide PA	UHMW-PE
Potassium bicarbonate	2	X	2	1
Potassium permanganate	2	2	4	1
Sodium cyanic	2	X	2	1
Sodium hydrochloride	3	X	4	1
Acid salt	2	X	3	1
Basic salt	1	X	2	1
Neutral salt	1	X	2	1
Organic Compounds	Acetal POM	Polypropylene	Polyamide PA	UHMW-PE
Acetone	1	1	1	1
Aniline	2	1	3	1
Benzene	1	3	2	4
Benzine	2	X	2	3
Butyl alcohol	2	X	2	1
Carbon disulphide	1	3	2	3
Carbon tetrachloride	1	3	1	3
Chloroform	1	4	3	4
Ethyl acetate	1	1	2	1
Ethyl alcohol	1	X	2	1
Heptane	2	1	1	2
Methyl alcohol	1	X	2	1
Methyl ethyl ketone	1	2	1	2
Nitrobenzene	2	2	2	1
Phenol	3	1	4	1
Gases	Acetal POM	Polypropylene	Polyamide PA	UHMW-PE
Carbon dioxide	3	1	1	1
Carbon monoxide	2	X	1	1
Chlorine	2	4	4	3
Hydrogen Sulfide	3	1	1	1
Sulphur dioxide	2	1	3	1
Other	Acetal POM	Polypropylene	Polyamide PA	UHMW-PE
Carbon tetrachloride	1	3	1	3
Beer	1	1	2	1
Fruit juice	1	2	2	1
Gasoline	1	1	2	1
Milk	1	1	1	1
Oil	1	3	1	1
Vinegar	1	1	2	1

Belting:

The following is a list of the top coat materials used in 7350 Series conveyor belting:

Material	Belt Number
Urethane	01, 02, 03, 05, 06, 09, 54, 55, 56, 53, 60, 61, 63, 68, 69, 72, 73, 75, 76, 77
PVC (non FDA approved)	08, 18, 59, 64
Silicone	50, 80, 81
Polyester	66
Nitrile	57
Urethane (hard)	58

Resistance to Materials: Belting

The following table provides the resistance to belt materials used in the conveyor to several chemicals. Application testing is recommended to determine long term material durability.

Legend:

1 = Good resistance | 3 = Limited resistance | 4 = Not recommended

Materials	Urethane	PVC (non FDA)	Silicone	Polyester	Urethane (hard)
Chemicals					
Acetic acid (glacial acetic acid)	4	3	1	1	4
Acetic acid 10 %	3	1	1	3	1
Acetic anhydride	3	4	1	1	4
Acetone	4	4	1	3	4
Aluminium salts	1	1	1	1	1
Alum	1	1	1	1	1
Ammonia, aqueous	3	1	1	3	1
Ammonia, gaseous	1	1	3	1	1
Ammonium acetate	1	1	1	1	1
Ammonium carbonate	1	1	1	1	1
Ammonium chloride	1	1	1	1	1
Ammonium nitrate	1	1	1	1	1
Ammonium phosphate	1	1	1	1	1
Ammonium sulphate	1	1	1	1	1
Amyl alcohol	1	4	3	1	1
Aniline	3	3	3	4	4
Barium salts	1	1	1	1	1
Benzaldehyde	4	4	4	4	4
Benzine (see also Motor fuels)	1	3	3	1	1
Benzoic acid	1	1	1	1	1
Benzol	3	4	4	3	3
Boric acid	1	1	1	1	1
Boric acid, solution	1	1	1	1	1
Bromine	4	4	4	4	4
Bromine water	4	3	1	4	3
Butane, gaseous	1	1	1	1	1
Butane, liquid	1	1	1	1	1
Butyl acetate	4	4	4	3	4
n-Butyl alcohol	1	3	1	1	1
Calcium chloride	1	1	1	1	1

Resistance to Materials: Belting (continued)

Legend:

1 = Good resistance | 3 = Limited resistance | 4 = Not recommended

Materials	Urethane	PVC (non FDA)	Silicone	Polyester	Urethane (hard)
Calcium nitrate	1	1	1	1	1
Calcium sulphate	1	1	1	1	1
Carbon disulphide	4	4	3	4	4
Carbon tetrachloride	3	4	4	4	3
Chlorine, liquid	4	4	4	4	4
Chlorine, gaseous, dry	4	4	4	4	4
Chlorine, gaseous, wet	4	4	4	4	4
Chlorine water	4	1	3	4	3
Chlorobenzene	4	4	4	4	4
Chloroform	4	4	4	4	4
Chlorosulphonic acid	4	4	4	4	4
Chromic acid	4	4	4	4	4
Chromium salts	1	1	1	1	1
Chromium trioxide	1	1	1	1	1
Citric acid	4	1	1	1	4
Copper salts	1	1	1	1	3
Cresols	3	3	3	4	3
Cresols, aqueous	3	3	3	3	3
Cyclohexane	4	4	4	1	4
Cyclohexanol	4	4	4	4	4
Cyclohexanone	4	4	4	4	4
Decahydronaphthalene	4	4	4	4	4
Dibutyl phthalate	3	4	1	4	4
Diethyl ether	4	4	4	4	4
Dimethyl formamide	4	4	3	4	4
1,4 Dioxan	4	4	3	4	4
Ether	4	4	4	4	4
Ethyl acetate	4	4	4	3	4
Ethyl alcohol, non-denatured 100%	1	3	3	1	1
Ethyl alcohol, non-denatured 96%	1	3	3	1	1
Ethyl alcohol, non-denatured 50%	1	3	3	1	1
Ethyl alcohol, non-denatured 10%	1	3	1	1	1
Ethyl benzene	4	4	4	4	4
Ethyl chloride	4	4	4	4	4
Ethylene chloride	4	4	4	4	4
2-Ethyl hexanol	1	3	1	1	1
Formaldehyde	1	3	1	3	1
Formic acid, dilute	4	1	1	3	3
Glycerine	1	1	1	1	1
Glycerine, aqueous	1	1	1	1	1
Glycol	1	3	1	1	1
Glycol, aqueous	1	1	1	1	1
Heptane	1	3	3	1	1
Hexane	1	3	3	1	1
Hydrochloric acid, conc.	3	1	4	3	1

Resistance to Materials: Belting (continued)

Legend:

1 = Good resistance | 3 = Limited resistance | 4 = Not recommended

Materials	Urethane	PVC (non FDA)	Silicone	Polyester	Urethane (hard)
Hydrochloric acid 10 %	3	1	1	1	1
Hydrofluoric acid 40 %	4	4	4	4	4
Hydrogen chloride, gaseous, dilute	3	1	3	3	1
Hydrogen chloride, gaseous, conc.	3	3	3	4	3
Hydrogen peroxide 10%	3	1	1	3	1
Hydrogen sulphide	3	3	3	3	3
Iron salts (sulphate)	1	1	1	1	1
Isooctane	1	3	3	1	1
Isopropyl alcohol	1	3	1	1	1
Lactic acid	1	3	1	1	1
Magnesium salts	1	1	1	1	1
Mercury	1	1	1	1	1
Mercury salts	1	1	1	1	1
Methyl alcohol, aqueous 50 %	3	3	1	1	1
Methyl alcohol (methanol)	1	3	1	1	1
Methyl ethyl ketone	4	4	1	3	4
Methylene chloride	4	4	4	4	4
Naphthalene	3	4	4	3	4
Nickel salts	1	1	1	1	1
Nitric acid	4	3	4	4	4
Nitrobenzene	4	4	1	3	4
Octane (see also isooctane)	1	3	4	1	1
Oleic acid	1	3	4	1	1
Oxalic acid	1	1	1	1	1
Ozone	1	3	3	1	3
Perchloroethylene	4	4	4	4	4
Phenol	3	3	1	4	3
Phenol, aqueous	4	3	1	4	3
Phosphoric acid 85 %	4	1	1	3	1
Phosphoric acid 50 %	1	1	1	1	1
Phosphoric acid 10 %	1	1	1	1	1
Phosphorus pentoxide	1	1	1	1	1
Potash lye 50 %	4	1	4	3	4
Potash lye 25 %	4	1	4	1	4
Potash lye 10 %	4	1	3	1	4
Potassium carbonate (potash)	1	1	1	1	1
Potassium chlorate	1	1	1	1	1
Potassium chloride	1	1	1	1	1
Potassium dichromate	1	1	1	1	1
Potassium iodide	1	1	1	1	1
Potassium nitrate	1	1	1	1	1
Potassium permanganate	1	1	1	1	1
Potassium persulphate	1	1	1	1	1
Potassium sulphate	1	1	1	1	1
Propane, gaseous	1	1	1	1	1

Resistance to Materials: Belting (continued)					
Legend: 1 = Good resistance 3 = Limited resistance 4 = Not recommended					
Materials	Urethane	PVC (non FDA)	Silicone	Polyester	Urethane (hard)
Propane, liquid	1	1	1	1	1
Pyridine	4	4	3	4	4
Silver salts	1	1	1	1	1
Soda lye 50% (see potash lye)	4	1	4	4	4
Soda lye 25%	4	1	4	3	4
Soda lye 10%	4	1	3	1	4
Sodium bisulphite	1	1	1	1	1
Sodium carbonate (natron)	1	1	1	1	1
Sodium carbonate (soda)	1	1	1	1	1
Sodium chlorate	1	1	1	1	1
Sodium chloride (common salt)	1	1	1	1	1
Sodium hydroxide (caustic soda)	4	1	4	1	4
Sodium hypochlorite	1	1	1	3	1
Sodium nitrate	1	1	1	1	1
Sodium nitrite	1	1	1	1	1
Sodium perborate	1	1	1	1	1
Sodium phosphate	1	1	1	1	1
Sodium sulphate (Glauber salt)	1	1	1	1	1
Sodium sulphide	1	1	1	1	1
Sodium sulphite	1	1	1	1	1
Sodium thiosulphate (fixing salt)	1	1	1	1	1
Stearic acid	1	1	1	1	1
Succinic acid	1	1	1	1	1
Sulphur	1	1	1	1	1
Sulphur dioxide	3	3	3	3	4
Sulphuric acid 96%	4	4	4	4	4
Sulphuric acid 50%	4	3	4	3	4
Sulphuric acid 25%	4	3	3	1	3
Sulphuric acid 10%	4	3	1	1	3
Tartaric acids	1	1	1	1	1
Tetrachloroethane	4	4	4	4	4
Tetrachloroethylene (perchloroethylene)	4	4	4	4	4
Tetrahydrofuran	4	4	4	4	4
Tetrahydronaphthalene	4	4	4	4	4
Thiophene	4	4	4	4	4
Tin II chlorides	1	1	1	1	1
Toluene	4	4	4	4	4
Trichloroethylene	4	4	4	4	4
Urea, aqueous	1	1	1	1	1
Water	1	1	1	1	1
Xylene	4	4	4	3	4
Zinc salts	1	1	1	1	1

Resistance to Materials: Belting (continued)

Legend:

1 = Good resistance | 3 = Limited resistance | 4 = Not recommended

Materials	Urethane	PVC (non FDA)	Silicone	Polyester	Urethane (hard)
Products					
Alum	1	1	1	1	1
Anti-freeze*	1	3	1	1	1
Aqua regia	4	4	4	4	4
Asphalt	1	3	3	1	1
Battery acid	4	4	4	4	4
Benzine	1	3	3	1	1
Bleaching lye (12.5%)	1	1	1	1	3
Bone oil	1	3	4	1	1
Borax	1	1	1	1	1
Brake fluid* Bosch	1	3	1	1	3
Brake fluid* Skydrol	4	4	3	4	4
Chloride of lime (aqueous suspension)	1	1	1	1	3
Chlorine (active)	4	4	4	4	4
Chrome baths* (technical)	1	3	3	1	1
Chromosulphuric acid	4	4	4	4	4
Cresol solution	3	3	4	4	4
Diesel oil	1	1	3	1	1
Fertilizer salts	1	1	1	1	1
Fixing salt	1	1	1	1	1
Floor wax	1	3	3	1	1
Formalin	1	3	3	1	1
Fuel oils*	1	1	3	1	1
Furniture polish*	1	3	3	1	1
Gypsum	1	1	1	1	1
Ink*	1	1	1	1	1
Linseed oil	1	3	1	1	1
Litex (styrene)	4	4	4	4	4
Mineral oils (non-aromatic)	1	1	1	1	1
Moth balls	3	4	3	3	3
Diesel oil*	1	1	3	1	1
Petrol (gasoline) DIN51635	1	3	3	1	1
Petrol, regular	1	3	3	1	1
Petrol, super	3	4	3	1	3
Motor oils*	1	1	1	1	1
Oil no. 3 (ASTM)	1	3	1	1	1
Oleum	4	4	4	4	4
Paraffin	1	1	1	1	1
Paraffin oil	1	1	1	1	1
Petroleum	1	3	3	1	1
Petroleum ether	1	3	4	1	1
Photographic developer	1	1	1	1	1

Bearings and Lubrication:

All bearings on the AquaPruf conveyors are sealed. The following outlines the sealed for life versus sealed with grease zerk locations. Any bearings with grease zerk installed should be greased with H1 FDA approved food grade lubricant. See Maintenance Manual for instructions.

- Bearing with grease zerk; Standard drive and idler bearings, center drive idler and drive bearings and 48mm diameter nosebar idler bearings
- Sealed for life bearing; 32 mm diameter nosebar idler bearings, iDrive2 motorized roller bearings

All gearmotors used on AquaPruf conveyor are sealed and may be mounted in any position. Changing gear oil lubrication may be needed over the life of the gearbox. Please check the appropriate gearmotor manual for instructions.

Support Stand Locations:

Support Stand Locations			
Symbol	Description	Distance	
		mm	in
A	Maximum distance back at drive end	610	24
B	Maximum distance back at idler end	762	30
C	Maximum distance between supports	2997	118

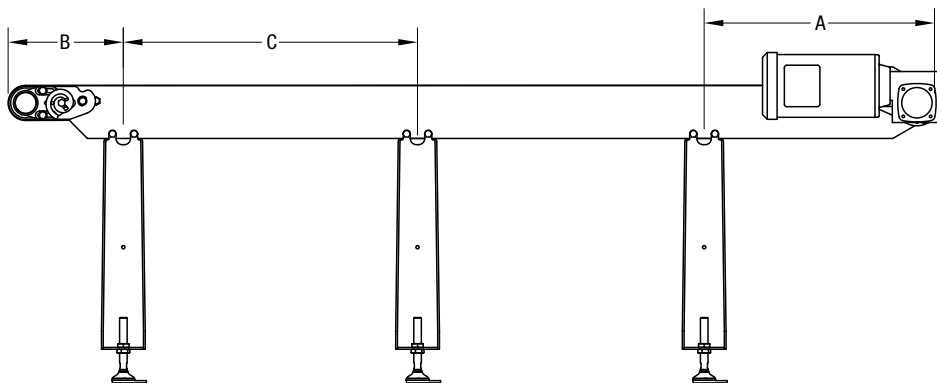

Conveyor Drive Shaft Tolerances:

End Drive, Belted and Modular Belt:

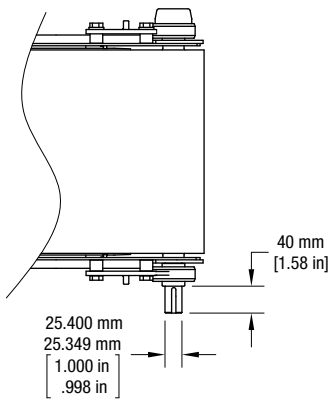

Center Drive:

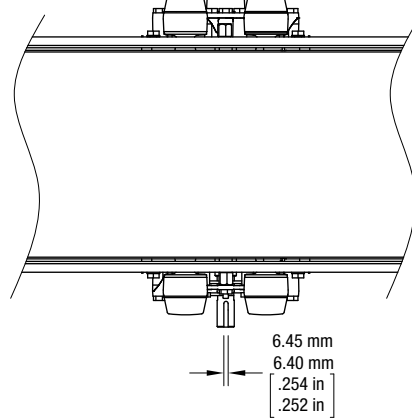

Nose Bar Drive:

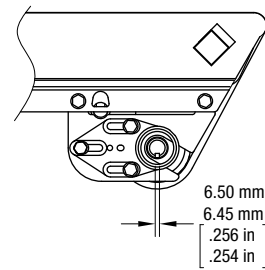
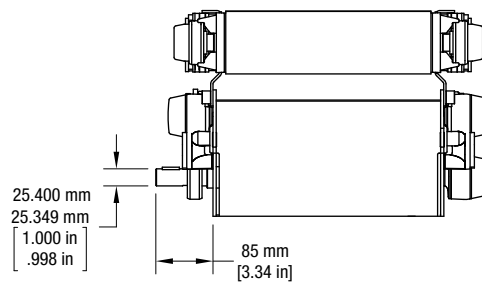
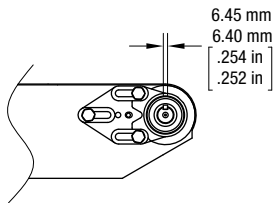
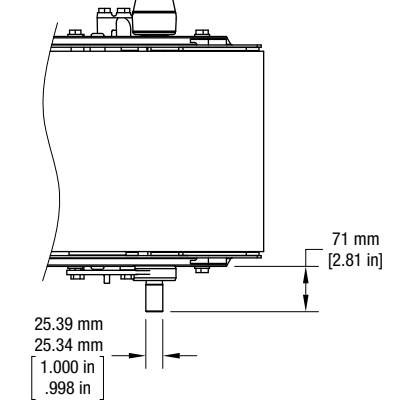

Note: Dimensions = mm (in)

Conveyor Noise Level (Decibel Ratings)

The actual noise level generated by the conveyor depends on several factors; the installation configuration, the product running on the conveyor, the surrounding equipment, the conveyor options and belt speed. The noise level generated by the conveyor is typically less than the general noise level of factory equipment.

Generally a higher belt speed will result in a higher noise level. In addition modular belt conveyors will run slightly louder than belted conveyors. The following charts provide basic decibel ratings for a typical conveyor arrangements.

Belted Conveyors:

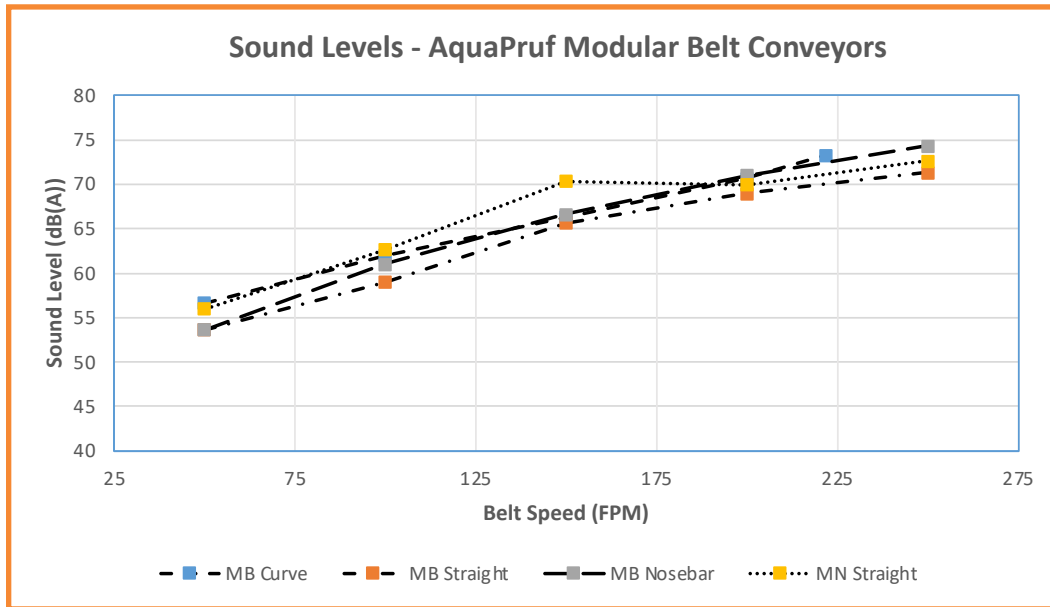

Modular Belt Conveyors:

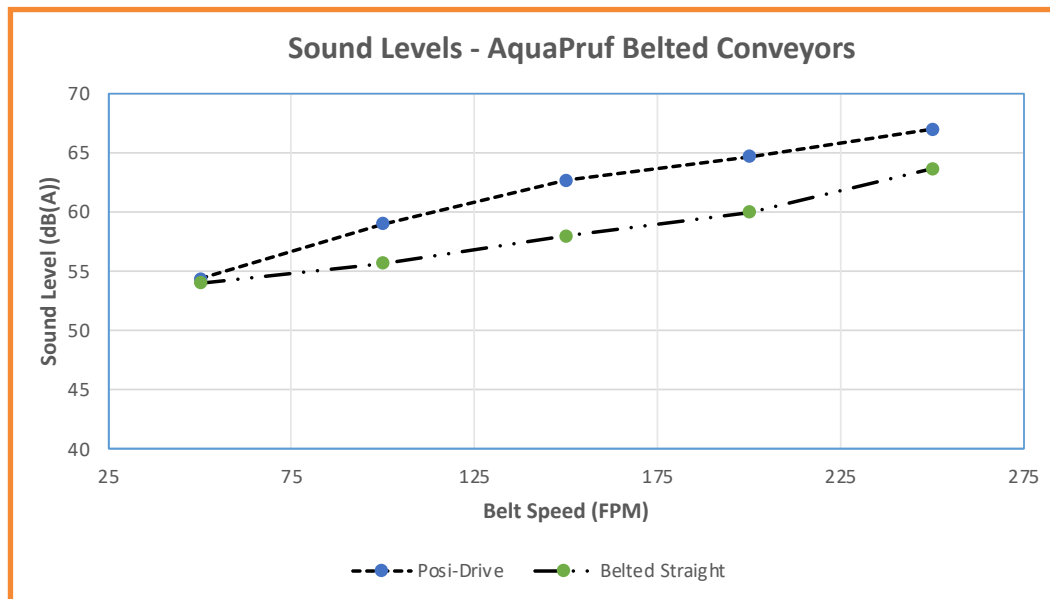

Maximum Load Capacity

The following Load Capacity Charts **do not** take into account the conveyor configuration, length or gearmotor selection. Your specific conveyor may not be capable of the maximum load condition. Please confirm your maximum load per application with the Dorner DTools program at www.dornerconveyors.com.

All load capacities shown are non-accumulated evenly distributed loads.

AquaPruf Series Belted End Drive Conveyor					
Belt Width		Pulling the Belt		Pushing the Belt	
mm	in	Kg	Lb	Kg	Lb
152	6	114	250	57	125
203	8	136	300	68	150
254	10	159	350	80	175
305	12	182	400	91	200
356	14	205	450	103	225
406	16	227	500	114	250
457	18	227	500	114	250
508	20	227	500	114	250
559	22	227	500	114	250
610	24	227	500	114	250
660	26	227	500	114	250
711	28	227	500	114	250
762	30	227	500	114	250
813	32	227	500	114	250
864	34	227	500	114	250
914	36	227	500	114	250
965	38	227	500	114	250
1016	40	227	500	114	250
1067	42	227	500	114	250
1118	44	227	500	114	250
1168	46	227	500	114	250
1219	48	227	500	114	250

AquaPruf Series Belted Center Drive Conveyor			
Belt Width		Pulling the Belt	
mm	in	Kg	Lb
152	6	114	250
203	8	136	300
254	10	159	350
305	12	182	400
356	14	205	450
406	16	227	500
457	18	227	500
508	20	227	500
559	22	227	500
610	24	227	500
660	26	227	500
711	28	227	500
762	30	227	500
813	32	227	500
864	34	227	500
914	36	227	500
965	38	227	500
1016	40	227	500
1067	42	227	500
1118	44	227	500
1168	46	227	500
1219	48	227	500

AquaPruf Series Belted Z-Frame Conveyor					
Belt Width		Pulling the Belt		Pushing the Belt	
mm	in	Kg	Lb	Kg	Lb
203	8	45	100	23	50
254	10	45	100	23	50
305	12	45	100	23	50
356	14	45	100	23	50
406	16	45	100	23	50
457	18	45	100	23	50
508	20	45	100	23	50
559	22	45	100	23	50
610	24	45	100	23	50

Maximum Load Capacity *(continued)*

AquaPruf Series Modular Belt Conveyor			
Belt Width		Pulling the Belt	
mm	in	Kg	Lb
150	5.9	182	400
200	7.9	205	450
250	9.8	250	550
300	11.8	273	600
350	13.8	295	650
400	15.7	318	700
450	17.7	318	700
500	19.7	341	750
550	21.7	341	750
600	23.6	341	750
650	25.6	341	750
700	27.6	341	750
750	29.5	341	750
800	31.5	341	750
850	33.5	341	750
900	35.4	341	750
950	37.4	341	750
1000	39.4	341	750
1050	41.3	341	750
1100	43.3	341	750
1150	45.3	341	750
1200	47.2	341	750

AquaPruf Series Modular Belt Curve Conveyor			
Belt Width		Pulling the Belt	
mm	in	Kg	Lb
152	6	182	400
229	9	182	400
305	12	227	500
381	15	227	500
457	18	227	500
533	21	227	500
610	24	227	500
686	27	227	500
762	30	227	500
838	33	227	500
914	36	227	500

AquaPruf Series Positive Drive Belt Conveyor			
Belt Width		Pulling the Belt	
mm	in	Kg	Lb
203	8	136	300
254	10	159	350
305	12	182	400
356	14	205	450
406	16	227	500
457	18	227	500
508	20	227	500
559	22	227	500
610	24	227	500
660	26	227	500
711	28	227	500
762	30	228	501
813	32	228	502
864	34	229	503
914	36	229	504
965	38	230	505
1016	40	230	506
1067	42	230	507
1118	44	231	508
1168	46	231	509
1219	48	232	510
914	36	227	500

AquaPruf Series Modular Belt Z-Frame Conveyor			
Belt Width		Pulling the Belt	
mm	in	Kg	Lb
200	7.9	45	100
250	9.8	45	100
300	11.8	45	100
350	13.8	45	100
400	15.7	45	100
450	17.7	45	100
500	19.7	45	100
550	21.7	45	100
600	23.6	45	100

No Load Torque:

No load torque is the amount of torque required to turn an empty conveyor. The torque value varies by conveyor length and configuration. The following charts provide basic values for an average length conveyor. Your specific conveyor may not be have a higher value. Please confirm your no load torque and maximum load per application with the Dorner DTools program at www.dornerconveyors.com.

AquaPruf Belted Sraight Conveyor - No load Torque					
Belt Width		Belted End Drive		Belted Center Drive	
mm	in	Nm	In-Lbs	Nm	In-Lbs
152	6	0.7	6	1	9
203	8	0.9	8	1.1	10
254	10	1.1	10	1.5	13
305	12	1.5	13	1.9	17
356	14	1.7	15	2.3	20
406	16	2.3	20	2.9	26
457	18	2.3	20	2.9	26
508	20	2.8	25	3.7	33
559	22	3.1	27	4	35
610	24	3.1	27	4	35
660	26	3.4	30	4.4	39
711	28	3.7	33	4.9	43
762	30	3.7	33	4.9	43
813	32	4	35	5.2	46
864	34	4.3	38	5.5	49
914	36	4.3	38	5.5	49
965	38	4.3	38	5.5	49
1016	40	4.5	40	5.9	52
1067	42	4.5	40	5.9	52
1118	44	4.7	42	6.2	55
1168	46	4.7	42	6.2	55
1219	48	5	44	6.4	57

Straight Modular Belt Conveyor:

The no load torque on modular belt straight conveyors is dependent on the conveyor length and width. Use the following formula to determine no load torque. Where:

L = conveyor length (mm)

W = conveyor width (mm)

BW = belt weight (kg) = $(W/1000)*((L*2)/1000)*8.7$ kg/square meter

PD = sprocket pitch diameter (mm) = 99 mm

$$\text{No load Torque (Nm)} = \text{BW}*(0.3)*((\text{PD}/2)/1000)$$

Example: AquaPruf Series Straight Modular Belt, 650 mm wide x 7000 mm long

$$\text{Belt weight (kg)} = (650/1000)*((7000*2)/1000)*8.7 = 79.2 \text{ kg}$$

$$\text{No load torque (Nm)} = 79.2*0.3*((99/2)/1000) = 1.18 \text{ Nm}$$

$$\text{No load torque (in-lb)} = (\text{Nm})*8.851 = 1.10*8.851 = 10.44 \text{ in-lb}$$

Curve Modular Belt Conveyor:

The torque calculations for curve conveyors are complicated and are very dependent on the conveyor save and configuration. Please confirm your no load torque and maximum load per application with the Dorner DTools program at www.dornerconveyors.com.

Belting and Coefficient of Friction

The coefficient of friction is used to determine the load a conveyor can carry. It effects a conveyor in two ways: the friction that exists between the conveyor belt and the bed surface, and if accumulating product, the friction that exists between the conveyor top surface and the product.

Coefficient of Friction, between the bottom of the conveyor belt and bed surface:

Product	Surfaces	Application Condition	Coefficient of Friction
AquaPruf Series Belted	Impregnated polyester fabric to anodized aluminum bed plate	Dry	0.33
AquaPruf Series Modular Belt	Acetal modular belt to UHMW wear strips	Dry	0.30

Coefficient of Friction, between the top surface of conveyor belt and product:

AquaPruf Series Belt		
The following table provides the coefficient of friction between steel product and various belt top surfaces. All factors below are assuming dry conditions.		
Belt Number	Top Surface Material and Type	Coefficient of Friction
01, 54, 58, 68, 73, 81	Smooth hard urethane	0.40
02, 59, 60, 61, 66, 72, 76, 79	Smooth medium urethane	0.50
03, 19, 55, 69, 75, 77, 78, 80	Glossy soft urethane	>1.0, do not accumulate
05, 06, 50, 53, 63	Impregnated polyester fabric	0.20
08, 18, 64	PVC, Very High friction	>1.0, do not accumulate

AquaPruf Series Modular Belt	
The following table provides the coefficient of friction between acetal modular belt and various products. All factors below are assuming dry conditions.	
Product Being Accumulated	Typical Coefficient of Friction
Steel	0.25
Glass	0.20
Aluminum	0.25
Plastic	0.25
Wood	0.30
Paper and Cardboard	0.30

Calculating Conveyor Load Capacity

There are several factor that effect the overall conveyor load of AquaPruf Series Conveyor. These include:

- Conveyor size and configuration
- Conveyor speed
- Application temperature
- Product accumulation
- Number of starts and stops per hour

Located online at www.dornerconveyors.com is the Dorner conveyor configuration tool, DTools. This tool allows you to configure your conveyor layout and determine the maximum load capacity for the conveyor. It is suggested that this program be used to calculate the conveyor load as the calculation is quite complicated. This configuration program however does not take into account temperature, dirty conditions, and conveyor starts and stops. If these conditions are part of your application please use the load reducing factors as shown below.

$$\text{Maximum Load} = (\text{Load from DTools})(\text{Temperature Factor})(\text{Start/Stop Factor})$$

Temperature Factor		
Ambient temperature can negatively affect the capacity of the conveyor.		
Temperature F	Temperature C	Temperature Factor
-4	-20	1.0
32	0	1.0
68	20	1.0
104	40	0.9
140	60	0.8

Start / Stop Factor	
Frequent Start / Stops of the conveyor can negatively affect the capacity of the conveyor. All start / stop applications must use a soft start mechanism such as a Frequency Inverter with a 1 second acceleration cycle.	
Application Condition	Start / Stop Factor
Continuous Run or 1 start/stop per hour	1.0
Maximum 10 starts/stop per hour	0.83
Maximum 30 starts/stop per hour	0.70
Greater than 30 starts/stop per hour	0.62

Calculating Conveyor Belt Speed:

AquaPruf Series Conveyors:

To calculate the conveyor belt speed you need to know the following factors:

- DR = Drive roller diameter or drive sprocket pitch diameter (mm)
- = 89 mm (3.5 in) for end and center drive belted conveyors
 - = 99 mm (3.9 in) for end drive modular belt conveyors
 - = 99 mm (3.9 in) for end positive drive belt conveyors

RPM = Revolutions per minute of gearmotor

$$\text{Belt Speed (m/min)} = \text{RPM} * (\text{DR}/1000) * 3.14$$

Example:

AquaPruf Series Belted End Drive, side mount gearmotor. The gearmotor is a 10:1 ratio with 173 rpm output.

$$\text{Belt Speed (m/min)} = (173) * (89/1000) * 3.14$$

$$\text{Belt speed (m/min)} = 48.3 \text{ m/min}$$

$$\text{Belt speed (ft/min)} = 48.3 \text{ m/min} * (3.28) = 158.4 \text{ ft/min}$$

Dorner AquaPruf Conveyors are Best for:

- Processed Foods
- Dairy
- Nutraceuticals
- Raw Meats & Poultry
- Fruits & Vegetables
- Pet Foods
- Pharmaceutical
- Ready-to-Eat Foods
- And More!

Sizes & Measurements

- 152 - 1524 mm (6 - 60 in) widths
- 914 - 25375 mm (36 - 999 in) lengths

Loads & Speeds

- 98 kg per square meter (20 lbs per square foot)
- Speeds up to 100 mpm (328 fpm)

Modular Belt Options

- Flat Modular Belt
- Friction Top
- Cleated
- Curve



Patented Sprocket Alignment Key



Flat Modular Belt

Belt Options

V-Guided and Positive Drive Belt Options

- Flat Belt
- Cleated
- Sidewall Cleated



Positive Drive



Flat Belt

Configurations



Straights



Curves



LPZ (Z-Frames), Nose-Overs & Horizontal to Inclines

Options



Nose Bar Transfers



Belt Lifters & Frame Cut-Outs



Belt Scrapers



Clean-in-Place

Other options available including Chutes, Drip Pans, Guiding, Hoppers and more.



Industrial



Flexible Chain



Pallet Systems



Sanitary Stainless Steel

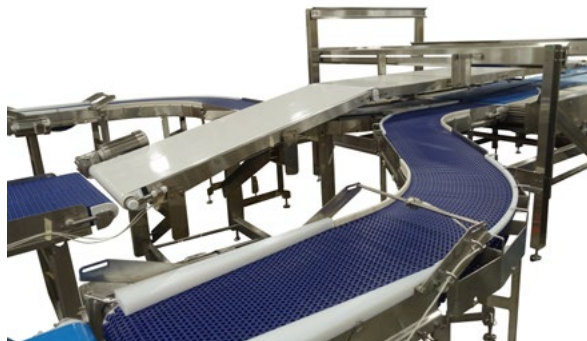

Engineered Solutions Group

Custom engineered solutions for almost any application.



CAD Configurator Tool

Industry leading tool! Configure your own custom conveyor in minutes.

TRANSFORMING CONVEYOR AUTOMATION

Contact Dorner

United States
+1-262-367-7600

Canada
+1-289-208-7306

Mexico
+52.33.30037400

Germany
+49 (0) 2461/93767-0

France
+33 (0)1 84 73 24 27

Malaysia
+604-626-2948



By Columbus McKinnon

DORNERCONVEYORS.COM



CONVEYANCE SOLUTIONS



MAGNETEK



© Dorner Mfg. Corp. 2026. All Rights Reserved.