

FDA Approved Materials
& Components

Fast, Simple to Use
Online Configurator

Rapid Deliveries

BISSC
Certified Conveyors



AquaGard[®]
Low Profile **LP**
CONVEYORS

Stainless Steel Conveyors for Dry, Wipe Down
and Wet Applications

DORNER[®]

Dorner AquaGard Conveyors are Best for:

- Baking
- Packaged Foods
- Pet Foods
- Secondary Packaging
- Snack Foods
- Tight Transfers
- Confectionary
- Elevation Changes
- And More!

AquaGard LP Series Specifications*

- Belted and Cleated Belt Models
- Loads up to 22.7 kg (50 lbs)
- Widths: 70 mm (2.75 in) to 457 mm (18 in)
- Lengths: 500 mm (19.1 in) to 8,485 mm (18 ft)
- Robust welded 304 Stainless Steel frame
- Available in straights only

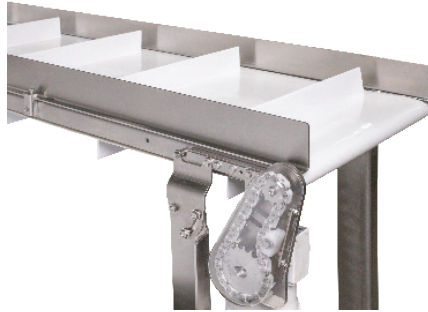

7350 Series Specifications

- Belted, Cleated Belt, Modular Belt, Modular Cleated Belt Models and Positive Drive Options
- Loads up to 341 kg (750 lbs)
- Widths: 152 mm (6 in) to 914 mm (36 in)
- Lengths: 914 mm (3 ft) to 25,000 mm (82 ft)
- FDA approved belting and plastic components
- 304 Stainless Steel frame
- Available in straights, curves or Z-Frame configurations



Straights



Curves
(Modular Belt Only)

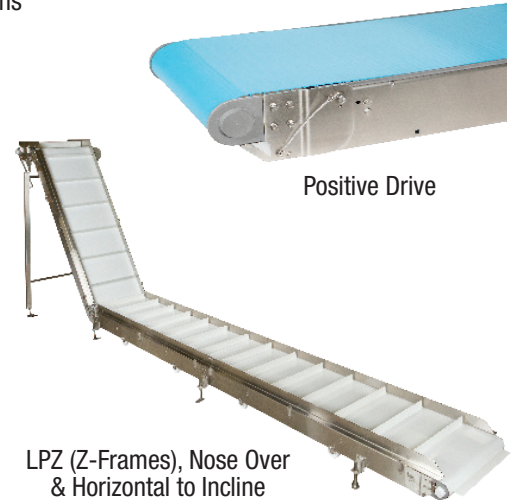

Positive Drive

LPZ (Z-Frames), Nose Over
& Horizontal to Incline

Options



Nose Bar Transfers



Powered Transfers



Variety of Guiding Options

Other options available including Roller Transfers, Chutes, Drip Pans, Formed Angle Stands, Hoppers and more.

*Please refer to the AquaGard 7350 Series manual for product information.

Sleek, Low Profile Design

- Quick, five-minute belt change for increased uptime
- Bolt slider mechanism for fast, single point belt tensioning
- V-Groove frame with V-Guided belt ensures accurate tracking
- Streamlined design fits where other conveyors do not
- Low profile, robust welded frame design, for easy cleaning
- Small 31.75mm (1-1/4 in) diameter end rollers for transfer of small products



Innovative and Durable

- 304 Stainless Steel welded frame with minimal horizontal surfaces
- Designed for wipe down and low pressure wash-down with non-caustic chemicals
- Tip-up tails for access inside the conveyor for cleaning and maintenance
- Compact and enclosed tensioning system providing smooth and snag-free cleaning
- Carriage bolt on guiding for easy set up

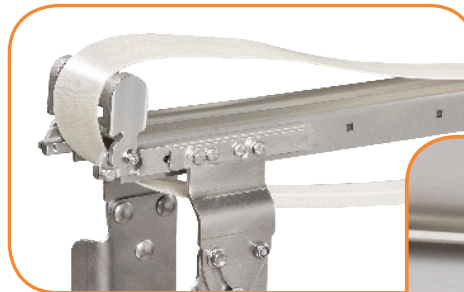

Tip-Up Tails



High Side Guide Block with Carriage Bolt

Engineered Solutions

- Dorner's Engineered Solutions Group can tailor fit AquaGard Conveyors for specific applications and product handling requirements
- With a custom-designed conveyor system in place and the help of highly specialized engineering, your products are processed faster, your services are delivered quicker, and your profits are increased
- Solutions include: chicaning, retracting tails, depositing and rejects, merging, product flow, and more!



The Benefits of Dorner AquaGard Conveyors

Industry Ready

- Designed and manufactured to food equipment standards
- BISSC certified conveyors
- FDA approved materials and components
- Washdown rated gearmotors and controls

A Focus on Speed

- Dorner sets the industry standard for rapid delivery
- Sanitary conveyors ship in as little as 10 business days
- Fast and effective design reduces cleaning preparation time

Industrial & Automation Conveyors

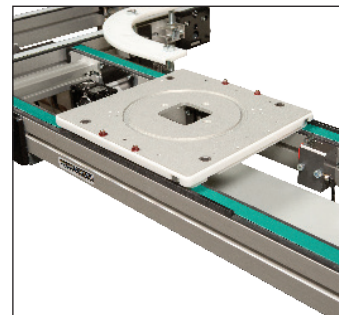
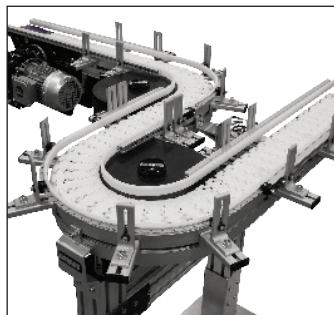
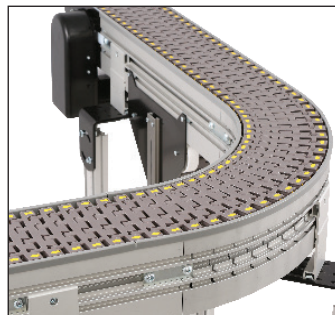
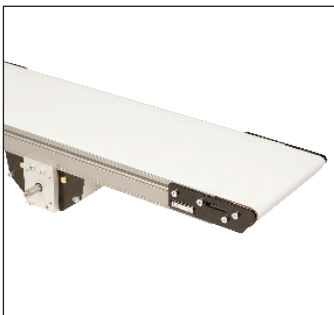

Sanitary Conveyors

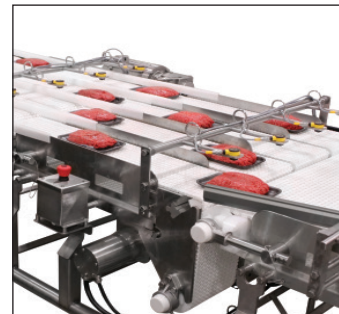
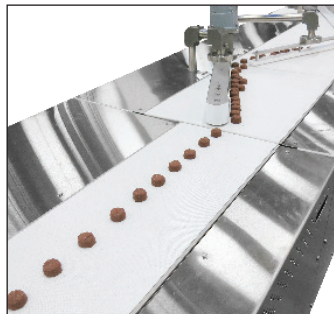
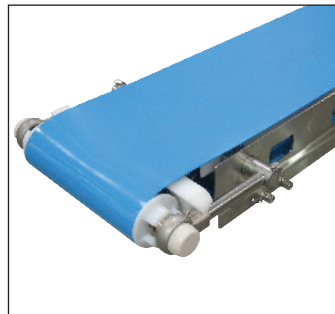
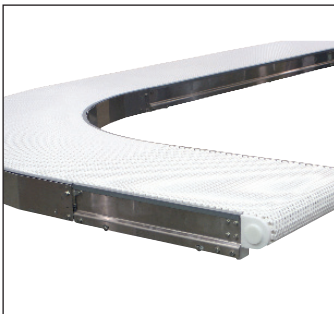

Parts



Service



Online Configurator



Warranty

Transforming Conveyor Automation

Dorner – North & South America

Dorner – U.S.A. Headquarters
975 Cottonwood Ave
Hartland, WI 53029, USA
(800) 397-8664
(262) 367-7600
info@dorner.com

Dorner – Canada
100-5515 North Service Road
Burlington, Ontario L7L 6G6
Canada
(289) 208-7306
info@dorner.com

Dorner – Latin America
Carretera a Nogales #5297,
Nave 11. Parque Industrial Nogales
Zapopan, Jalisco C.P. 45222
Mexico
+52.33.30037400
info.latinamerica@dorner.com

DORNER®



Dorner – Europe

Dorner – Germany
Karl-Heinz-Beckurts-Straße 7
52428 Jülich,
Germany
+49 (0) 2461/93767-0
info.europe@dorner.com

Dorner – France
8 rue des Frères Caudron
78140 Velizy-Villacoublay
France
+33 (0)1 84 73 24 27
info.france@dorner.com

Dorner – Asia

128 Jalan Permatang Damar Laut, Bayan Lepas 11960
Penang, Malaysia
+604-626-2948 | info.asia@dorner.com

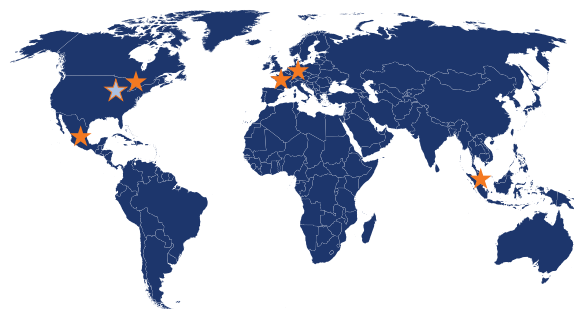

www.dornerconveyors.com