

AquaGard[®] LP Support Stands

Installation, Maintenance & Parts Manual

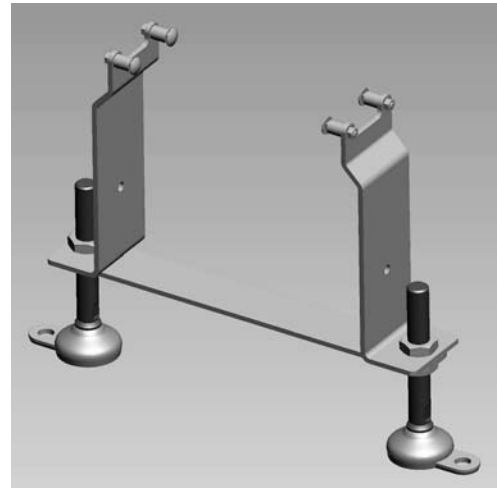

For other service manuals visit our website at:
www.dornerconveyors.com/manuals-literature

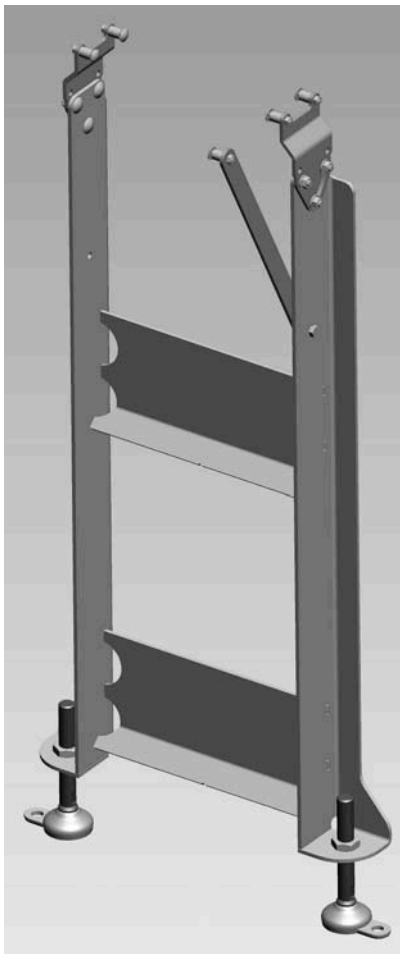

Original Instructions

851-969-EU Rev. A

Record Conveyor Serial Number Here

Warnings - General Safety

⚠ WARNING

The safety alert symbol, black triangle with white exclamation, is used to alert you to potential personal injury hazards.

⚠ DANGER



Climbing, sitting, walking or riding on conveyor will cause severe injury.
KEEP OFF CONVEYORS.

⚠ DANGER



DO NOT OPERATE CONVEYORS IN AN EXPLOSIVE ENVIRONMENT.

⚠ DANGER

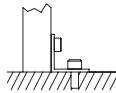

Supports marked with this symbol must be anchored to the floor. Supports not anchored to floor will tip, causing severe injury or death.
SUPPORT MUST BE ANCHORED TO FLOOR.

⚠ WARNING



LOCK OUT POWER before removing guards or performing maintenance. Exposed moving parts can cause serious injury.

⚠ WARNING



Loosening stand height or angle adjustment screws may cause conveyor sections to drop down, causing severe injury.
SUPPORT CONVEYOR SECTIONS PRIOR TO LOOSENING STAND HEIGHT OR ANGLE ADJUSTMENT SCREWS.

⚠ WARNING



Dorner cannot control the physical installation and application of conveyors. Taking protective measures is the responsibility of the user.
When conveyors are used in conjunction with other equipment or as part of a multiple conveyor system, **CHECK FOR POTENTIAL PINCH POINTS** and other mechanical hazards before system start-up.

Product Description

Refer to **Figure 1** for typical stand components.

1	Support Stand
2	Stand Mounting Bracket
3	Diagonal Brace
4	Foot Pad

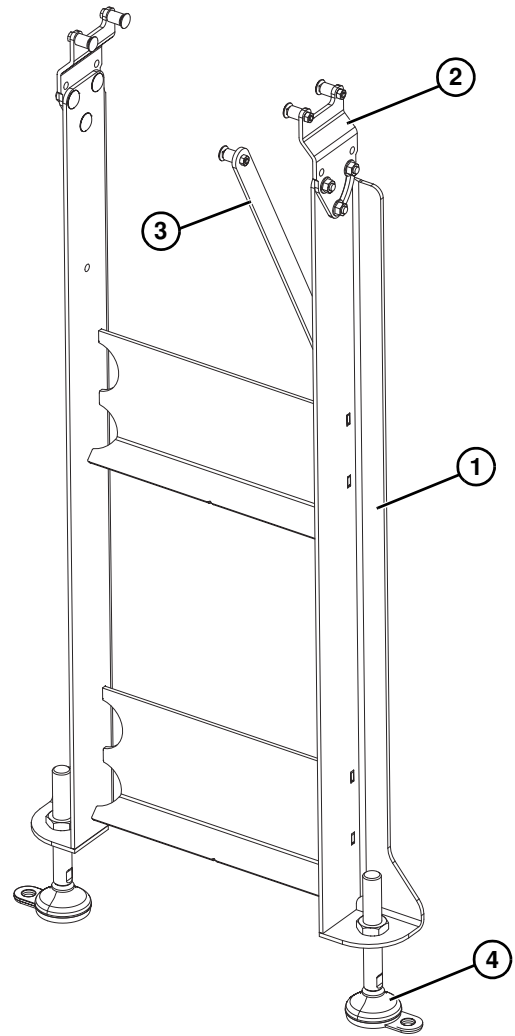
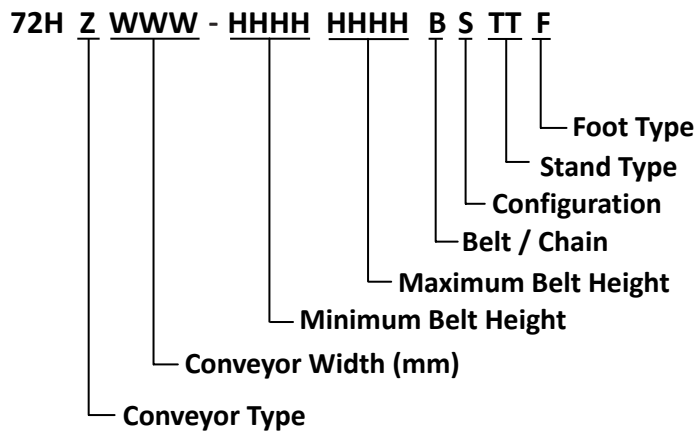

Figure 1

Specifications

Support Stands



Specifications

Fastener Torque Specifications

	Hex Head		Set Screw	
	Hex Size	Torque	Hex Size	Torque
M3 x 0.5	5.5 mm	0.9 Nm (8 in lbs)	2 mm	0.2 Nm (1.7 in lbs)
M4 x 0.7	7 mm	2.3 Nm (20 in lbs)	2 mm	0.7 Nm (6 in lbs)
M5 x 0.8	8 mm	4.6 Nm (40 in lbs)	2.5 mm	1.5 Nm (13 in lbs)
M6 x 1.0	10 mm	7.8 Nm (69 in lbs)	3 mm	2.5 Nm (22 in lbs)
M8 x 1.25	13 mm	19.0 Nm (169 in lbs)	4 mm	6.0 Nm (53 in lbs)
M10 x 1.5	16 mm	38.0 Nm (335 in lbs)	5 mm	12.0 Nm (106 in lbs)

Dorner recommends FDA approved grease on all threaded stainless steel fasteners.

Required Tools

- Level
- 10 mm wrench
- 13 mm wrench
- 30 mm wrench or large adjustable wrench (x2)

Recommended Installation Sequence

- Attach the stand(s) to the conveyor.
- Attach the diagonal bracing, if applicable.
- Adjust the stand height and level. Refer to “Stand Height Adjustment” on page 8.

Attach Stands to Conveyor

⚠ DANGER

Supports marked with this symbol must be anchored to the floor. Supports not anchored to floor will tip, causing severe injury or death.
SUPPORT MUST BE ANCHORED TO FLOOR.

1. Properly support the conveyor or place the conveyor upside down on a flat surface.

⚠ WARNING

Failure to secure nuts may cause conveyor sections to drop down causing severe injury. TIGHTEN NUTS AFTER ADJUSTMENT.

2. Fixed Height Stands: Loosen the three nuts (**Figure 2, item 1**) on stand bracket screws, and adjust bracket (**Figure 2, item 2**) so that the top of bracket is at the same angle as the conveyor (**Figure 2, item 3**).

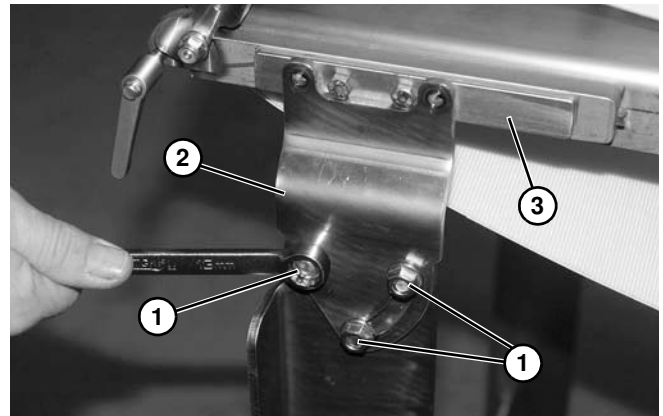

Figure 2

3. Idler End: Attach the bracket (**Figure 3, item 1**) to the conveyor with two screws (**Figure 3, item 2**) on each side.

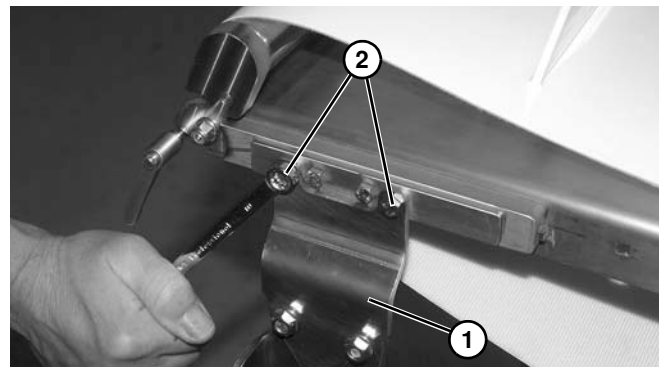

Figure 3

4. Center (if applicable): Attach stand to the conveyor frame with two spacers (**Figure 4, item 1**) and two carriage bolts and nuts (**Figure 4, item 2**) on each side.

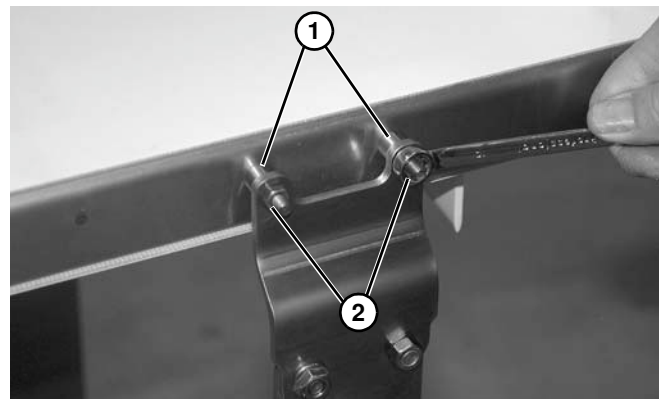

Figure 4

Installation

5. Drive End: Attach stand to the conveyor frame with one spacer (**Figure 5, item 1**) using a carriage bolt and nut (**Figure 5, item 2**), and a screw (**Figure 5, item 3**) on each side.

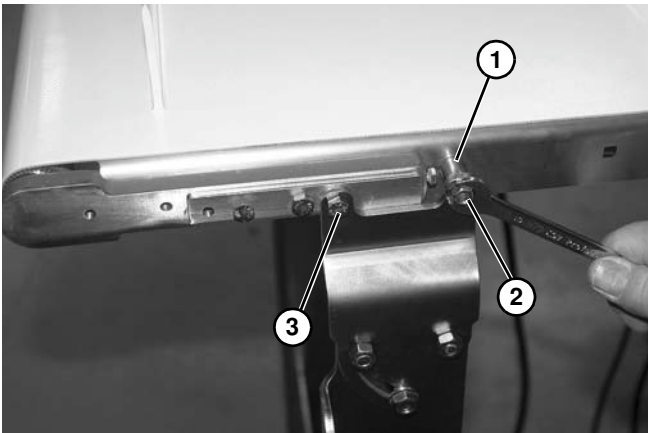

Figure 5

6. Tighten screws.
7. Fixed Height Stands: Adjust the bracket angle on the slotted brackets (**Figure 6, item 1**) to match the conveyor angle and tighten the three nuts (**Figure 6, item 2**).

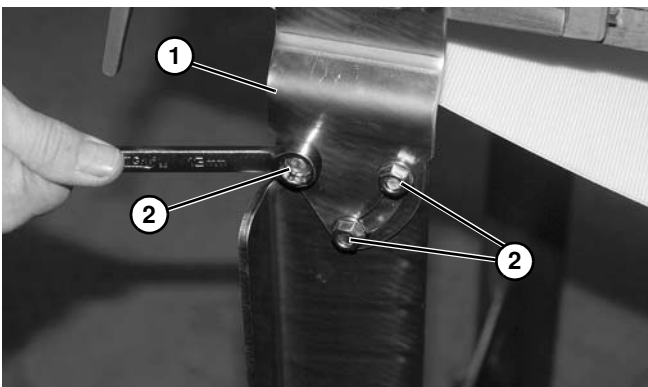

Figure 6

8. Repeat for the remaining stands.

Diagonal Brace Attachment

1. Attach the brace (**Figure 7, item 1**) to the stand with screw (**Figure 7, item 2**) and nut. Do not tighten at this time.

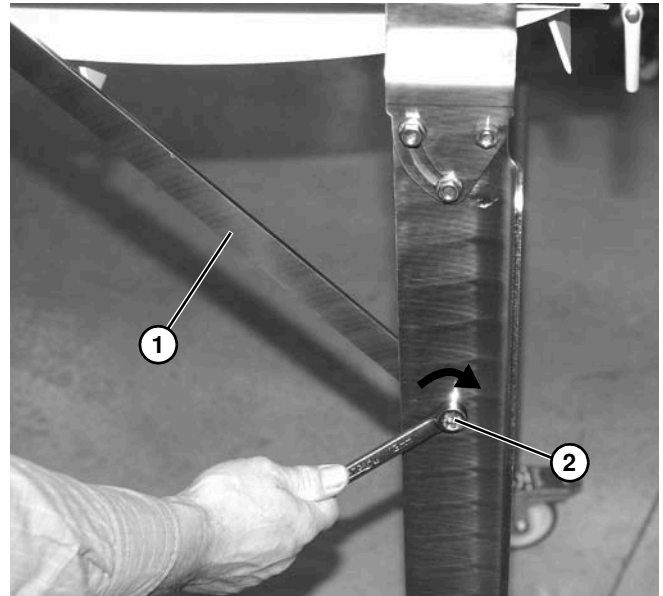

Figure 7

2. Install carriage bolt (**Figure 8, item 1**) through square hole (**Figure 8, item 2**) in conveyor.

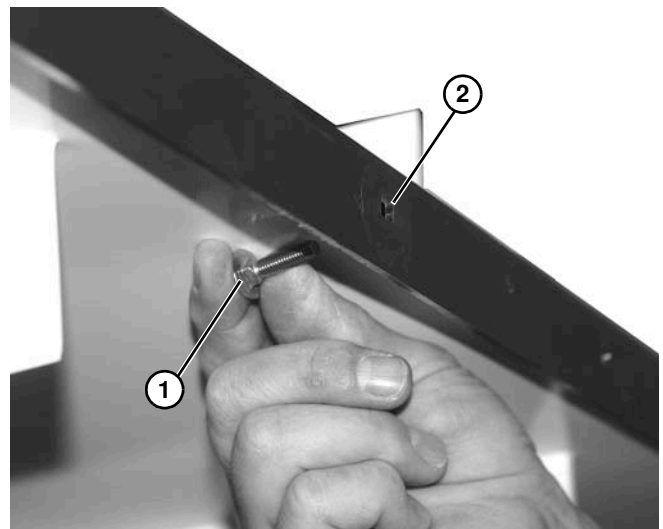

Figure 8

3. Install spacer (**Figure 9, item 1**) and brace (**Figure 9, item 2**) onto carriage bolt.

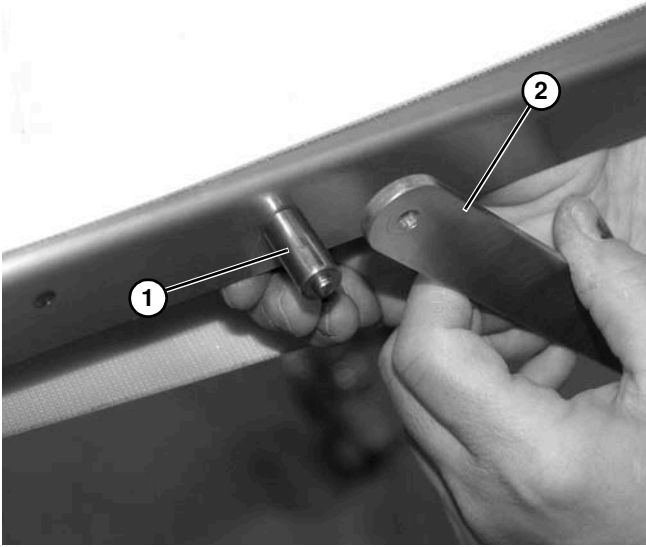

Figure 9

4. Install and tighten nut (**Figure 10, item 1**).

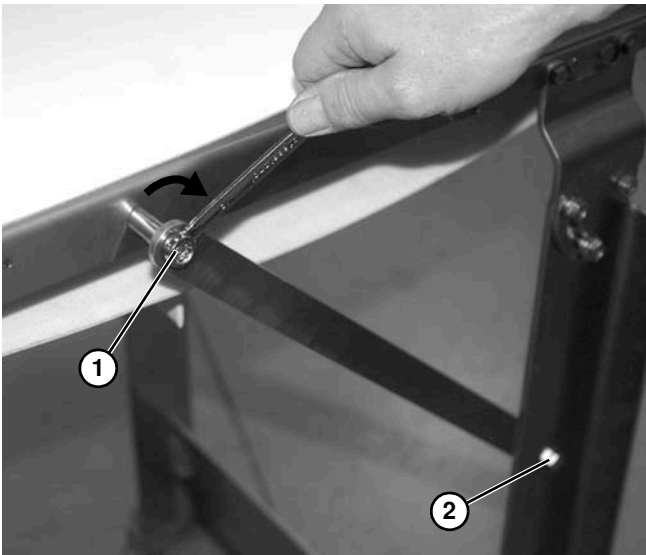

Figure 10

5. Tighten lower screw (**Figure 10, item 2**) and nut.
6. Repeat for the opposite leg.
7. Tighten all hardware.

Preventive Maintenance and Adjustment

Required Tools

- Level
- 10 mm wrench
- 13 mm wrench
- 30 mm wrench or large adjustable wrench (x2)

Stand Height Adjustment

⚠ WARNING	
	
SEVERE HAZARD! DO NOT EXCEED THE MAXIMUM HEIGHT OF 152 mm (6") from the floor to the bottom of the stand. Exceeding the maximum height will allow parts to separate and may cause serious injury.	

⚠ WARNING	
	
Loosening stand height or angle adjustment nuts may cause conveyor sections to drop down, causing severe injury. SUPPORT CONVEYOR SECTIONS PRIOR TO LOOSENING STAND HEIGHT OR ANGLE ADJUSTMENT NUTS.	

1. Support conveyor.

2. Loosen the upper nut (**Figure 11, item 1**) on the foot stem.

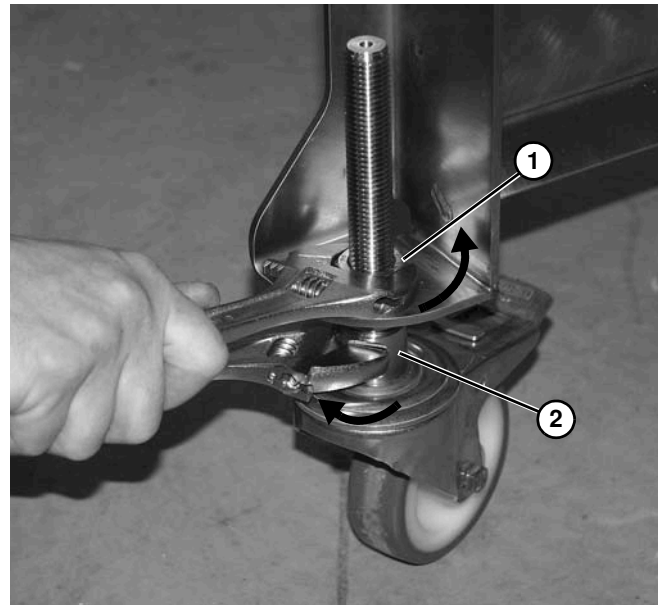

Figure 11

3. Rotate the foot stem (**Figure 11, item 2**) to raise or lower the stand (**Figure 12**).

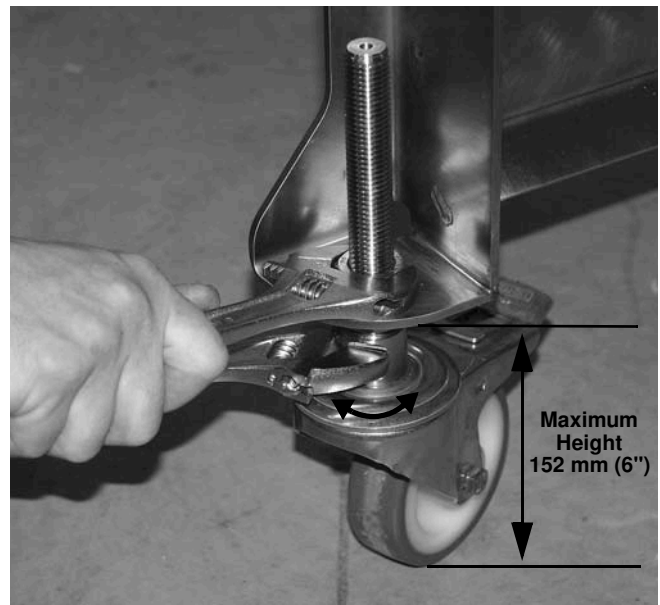

Figure 12

4. Repeat steps on the opposite stand leg.

Preventive Maintenance and Adjustment

5. Level the conveyor.

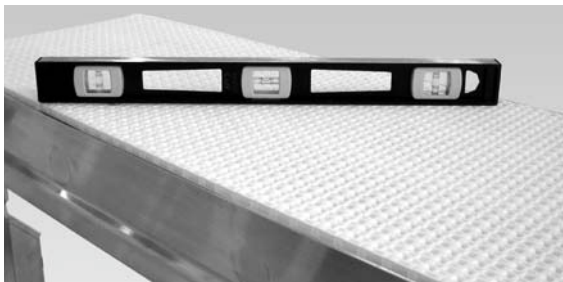

Figure 13

⚠ WARNING	
	
Failure to secure nuts may cause conveyor sections to drop down causing severe injury. TIGHTEN NUTS AFTER ADJUSTMENT.	

6. Tighten the upper nut to secure each foot assembly.



Figure 14

Conveyor Angle Adjustment

⚠ WARNING	
	
Loosening stand height or angle adjustment nuts may cause conveyor sections to drop down, causing severe injury. SUPPORT CONVEYOR SECTIONS PRIOR TO LOOSENING STAND HEIGHT OR ANGLE ADJUSTMENT SCREWS.	

1. Fixed Height Stands: Loosen the nuts on both sides and adjust the slotted bracket to the same angle as the conveyor.

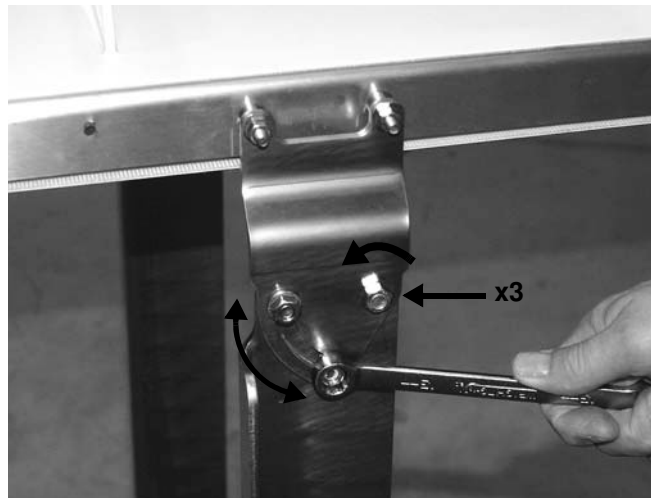



Figure 15

⚠ WARNING	
	
Failure to secure nuts may cause conveyor sections to drop down causing severe injury. TIGHTEN SCREWS AFTER ADJUSTMENT.	

2. Tighten the screws.
3. Adjust the stand height. Refer to “Stand Height Adjustment” on page 8.

Service Parts

NOTE

For replacement parts other than those shown in this section, contact an authorized Dorner distributor or Dorner directly. Recommended Critical Service Parts and Kits are identified by the Key Service Parts symbol . Dorner recommends keeping these parts on hand.

Fixed Height Stands

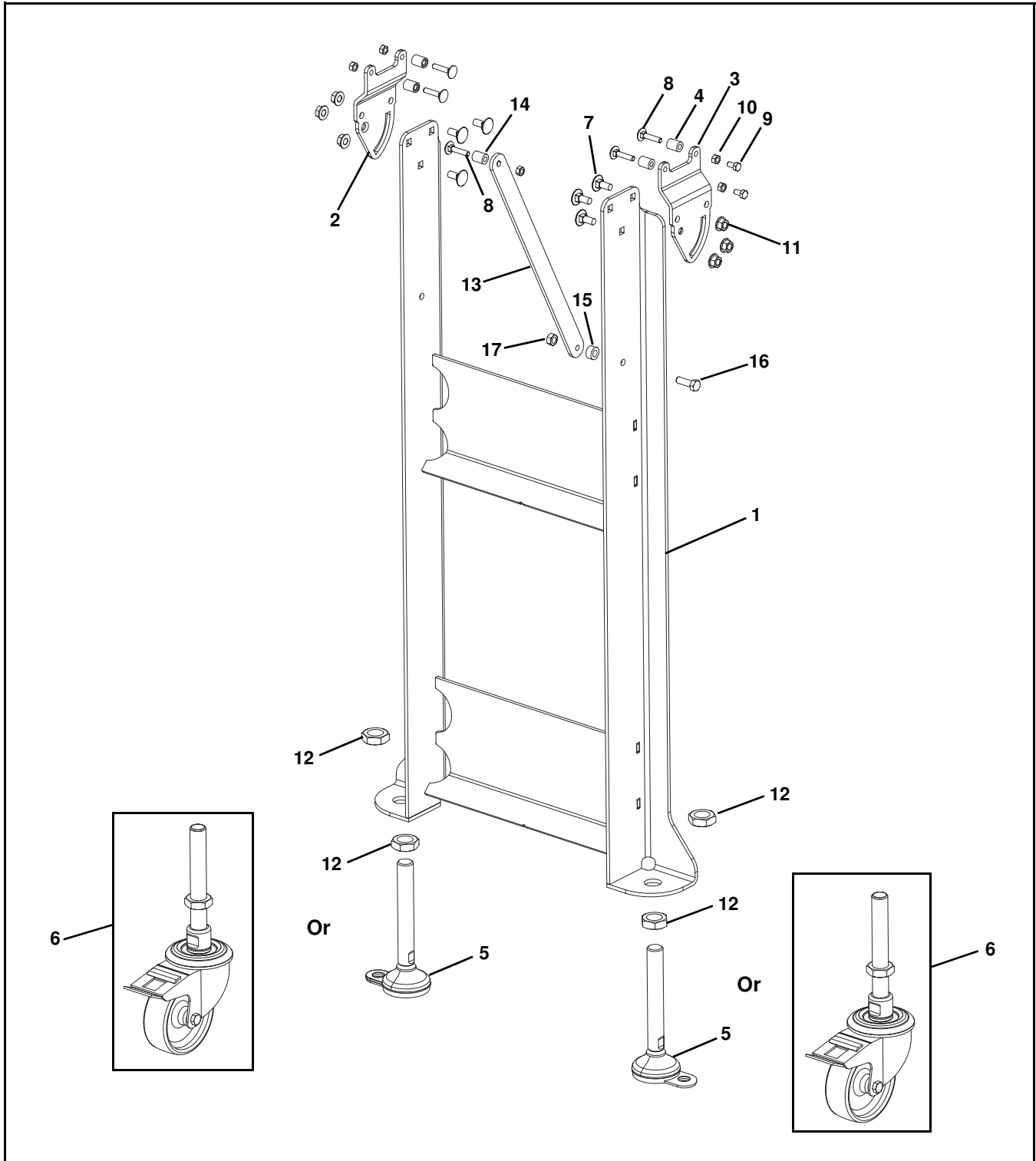

AquaGard® LP Support Stands

Item	Part Number	Description
1	-----	Consult Factory for Stand Frame Part Number
2	531087	Bracket for Conveyor Widths 203 and Under, Left Hand
	531089	Bracket for Conveyor Widths 254 and Wider, Left Hand
3	531088	Bracket for Conveyor Widths 203 and Under, Right Hand
	531090	Bracket for Conveyor Widths 254 and Wider, Right Hand
4	531092	Tube Spacer for Conveyor Widths 203 and Under (conveyor frame mount)
5	807-3724	Foot Pads
6	458309	Casters
7	807-3540	Carriage Bolt, M8 x 20 mm
8	900630MSS	Carriage Bolt, M6 x 30 mm (conveyor frame mount)
9	960612MSS	Hex Head Cap Screw, M6-1.00 x 12 mm (conveyor tail mount)
10	990601MSS	Nut (conveyor frame mount)
11	990813MSS	Hex Nut
12	992010MSS	Hex Jam Nut
13	531097-LLLLL-M	Diagonal Brace
14	531092	Tube Spacer
15	531098-B	Tube Spacer for Conveyor Widths 152 and Under
	531098-A	Tube Spacer for Conveyor Widths 203 and Wider
16	960825MSS	Hex Head Cap Screw, M8-1.25 x 25 mm
17	990801MSS	Hex Nut
LLLLL = Part length in mm.		
Example: Part length = 1000 mm LLLLL = 01000		
Service parts can be obtained through your distributor or directly from Dorner Mfg. Corp. (800) 397-8664 or customerservice@dorner.com		

Service Parts

Low Height Stands

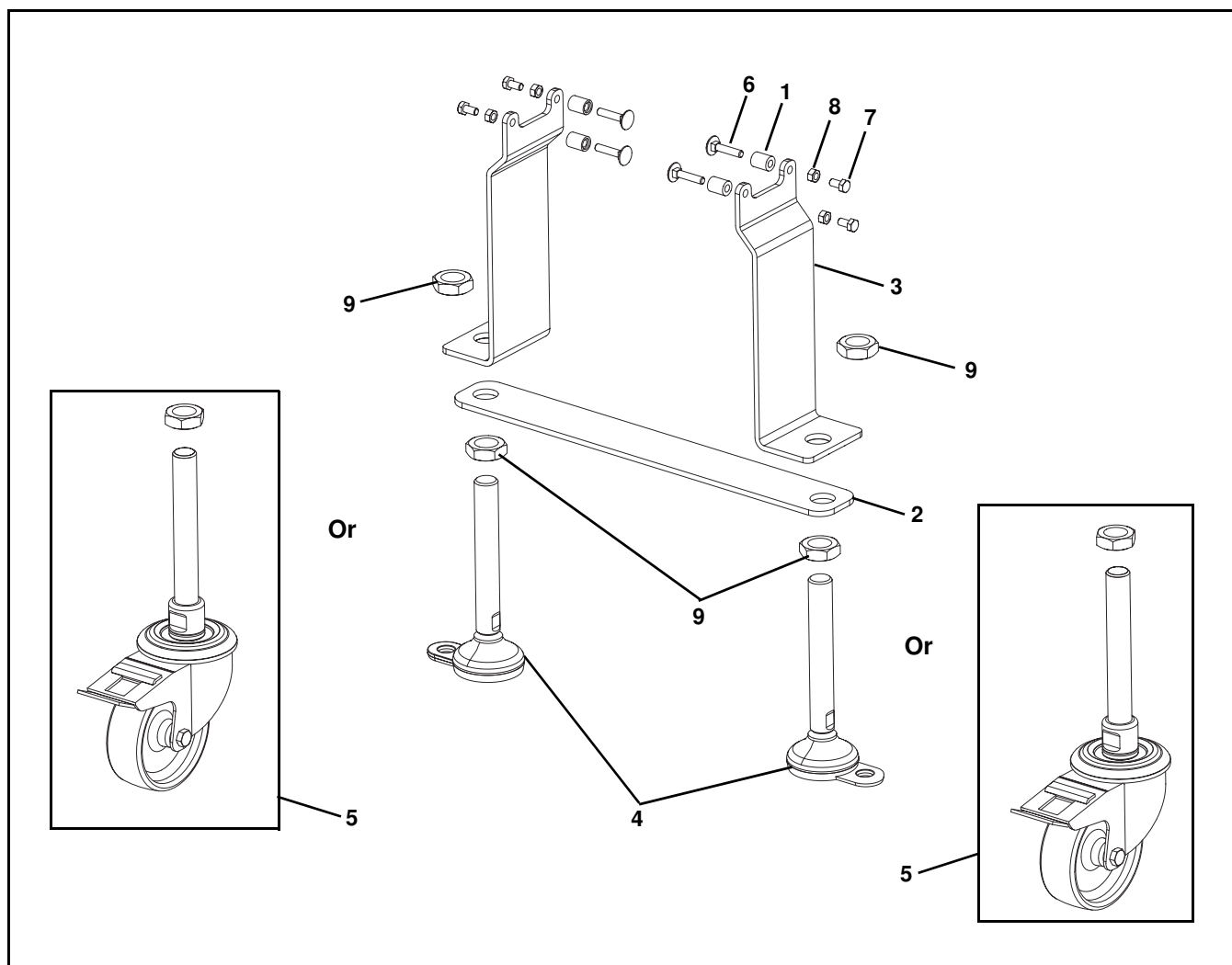

Item	Part Number	Description
1	531092	Spacer (conveyor frame mount)
2	531095- <u>WWW</u> -M	Tie Bracket
3	531094- <u>LLLL</u>	Stand Bracket for Conveyor Widths 152 and Under
	531093- <u>LLLL</u>	Stand Bracket for Conveyor Widths 203 and Wider
4	807-3724	Foot Pads
5	458309	Casters
6	900630MSS	Carriage Bolt, M6 x 30 mm (conveyor frame mount)
7	960612MSS	Hex Head Cap Screw, M6-1.00 x 12 mm (conveyor tail mount)
8	990601MSS	Nut (conveyor frame mount)
9	992010MSS	Hex Jam Nut
<u>WWW</u> = Conveyor width reference in mm 0070, 0095, 0152, 0203, 0254, 0305, 0406, & 0457		
<u>LLLL</u> = Part length in mm.		
Example: Part length = 465 mm <u>LLLL</u> = 00465		
Service parts can be obtained through your distributor or directly from Dorner Mfg. Corp. (800) 397-8664 or customerservice@dorner.com		

Return Policy

Returns must have prior written factory authorization or they will not be accepted. Items that are returned to Dorner without authorization will not be credited nor returned to the original sender. When calling for authorization, please have the following information ready for the Dorner factory representative or your local distributor:

1. Name and address of customer.
2. Dorner part number(s) of item(s) being returned.
3. Reason for return.
4. Customer's original order number used when ordering the item(s).
5. Dorner or distributor invoice number. Include part serial number if available.

A representative will discuss action to be taken on the returned items and provide a Returned Materials Authorization (RMA) number for reference. RMA will automatically close 30 days after being issued. To get credit, items must be new and undamaged. There will be a return charge on all items returned for credit, where Dorner was not at fault. It is the customer's responsibility to prevent damage during return shipping. Damaged or modified items will not be accepted. The customer is responsible for return freight.

Product Line	Product Type								Engineered to order parts
	Standard Products								
	Conveyors	Gearmotors & Mounting Packages	Support Stands	Accessories	Spare Parts (non-belt)	Spare Belts - Standard Flat Fabric	Spare Belts - Cleated & Spec. Fabric	Spare Belts - Plastic Chain	All equipment and parts
1100 Series	30% return fee for all products except: 50% return fee for conveyors with modular belt, cleated belt or speciality belts All Electrical items are assigned original manufacturers return policy.						non-returnable		case-by-case
2200 Series									
3200 Series									
Pallet Systems									
FlexMove/SmartFlex									
GAL Series									
All Electrical	50% return fee for all products						non-returnable		case-by-case
7100 Series									
7200/7300 Series									
AquaGard 7350 Series Version 2									
GES Series									
AquaGard 7350/7360 Series	non-returnable								
AquaPruf Series	non-returnable								

Returns will not be accepted after 60 days from original invoice date. The return charge covers inspection, cleaning, disassembly, disposal and reissuing of components to inventory. If a replacement is needed prior to evaluation of returned item, a purchase order must be issued. Credit (if any) is issued only after return and evaluation is complete.

Dorner has representatives throughout the world. Contact Dorner for the name of your local representative. Our Customer Service Team will gladly help with your questions on Dorner products.

For a copy of Dorner's Warranty, contact Dorner, an authorized sales channel or visit our website: www.dorner.com.

For replacement parts, contact an authorized Dorner Service Center or the factory.

www.dorner.com



© Dorner Mfg. Corp. 2021. All Rights Reserved.

Dorner – North & South America

Dorner – U.S.A.

Headquarters
 975 Cottonwood Ave
 Hartland, WI 53029, USA
 (800) 397-8664
 (262) 367-7600
info@dorner.com

Dorner – Canada

100-5515 North Service Road
 Burlington, Ontario L7L 6G6
 Canada
 (289) 208-7306
info@dorner.com

Dorner – Latin America

Carretera a Nogales #5297, Nave 11.
 Parque Industrial Nogales
 Zapopan, Jalisco C.P. 45222 México
 +52.33.30037400 | info.latinamerica@dorner.com

Dorner – Europe

Dorner – Germany

Karl-Heinz-Beckurts-Straße 7
 52428 Jülich,
 Germany
 +49 (0) 2461/93767-0
info.europe@dorner.com

Dorner – France

8 rue des Frères Caudron
 78140 Velizy-Villacoublay
 France
 +33 (0)1 84 73 24 27
info.france@dorner.com

Dorner – Asia

128 Jalan Permatang Damar Laut, Bayan Lepas 11960
 Penang, Malaysia
 +604-626-2948 | info.asia@dorner.com